



Standard Test Method for Cathodic Disbonding of Pipeline Coatings Subjected to Elevated Temperatures¹

This standard is issued under the fixed designation G 42; the number immediately following the designation indicates the year of original adoption or, in the case of revision, the year of last revision. A number in parentheses indicates the year of last reapproval. A superscript epsilon (ε) indicates an editorial change since the last revision or reapproval.

1. Scope

1.1 This test method describes an accelerated procedure for determining comparative characteristics of insulating coating systems applied to steel pipe exterior for the purpose of preventing or mitigating corrosion that may occur in underground service where the pipe will be exposed to high temperatures and is under cathodic protection. This test method is intended for use with samples of coated pipe taken from commercial production and is applicable to such samples when the coating is characterized by function as an electrical barrier.

1.2 This test method is intended for testing coatings submerged or immersed in the test solution at elevated temperature. When it is impractical to submerge or immerse the test specimen, Test Method G 95 may be considered where the test cell is cemented to the surface of the coated pipe specimen. If room temperatures are required, see Test Method G 8. If a specific test method is required with no options, see Test Method G 80.

1.3 The values stated in SI units to three significant decimals are to be regarded as the standard. The values given in parentheses are for information only.

1.4 *This standard does not purport to address all of the safety concerns, if any, associated with its use. It is the responsibility of the user of this standard to establish appropriate safety and health practices and determine the applicability of regulatory limitations prior to use.*

2. Referenced Documents

2.1 ASTM Standards:

G 8 Test Methods for Cathodic Disbonding of Pipeline Coatings²

G 12 Test Method for Nondestructive Measurement of Film Thickness of Pipeline Coatings on Steel²

G 80 Test Method for Specific Cathodic Disbonding of Pipeline Coatings²

¹ This method is under the jurisdiction of ASTM Committee D01 on Paint and Related Coatings, Materials, and Applications and is the direct responsibility of Subcommittee D01.48 on Durability of Pipeline Coatings and Linings.

Current edition approved May 10, 1996. Published July 1996. Originally published as G 42 – 75 T. Last previous edition G 42 – 90.

² *Annual Book of ASTM Standards*, Vols 06.02.

G 95 Test Method for Cathodic Disbondment Test of Pipeline Coatings (Attached Cell Method)²

3. Summary of Test Method

3.1 This test method subjects the coating on the test specimen to electrical stress in a highly conductive electrolyte. The coating is artificially perforated before starting the test. The electrical stress is produced by connecting the test specimen to the negative terminal of a source of direct current and by connecting an anode to the positive terminal. Electrical instrumentation is provided for measuring the current flowing in the cell. The electrical potential is also measured and the specimen is physically examined at intervals during the test period and upon conclusion of the test.

3.1.1 The cathodic stress is applied under conditions of a constant-elevated temperature.

4. Significance and Use

4.1 Damage to pipe coating is almost unavoidable during transportation and construction. Breaks or holidays in pipe coatings may expose the pipe to possible corrosion since, after a pipe has been installed underground, the surrounding earth will be moisture-bearing and will constitute an effective electrolyte. Applied cathodic protection potentials may cause loosening of the coating, beginning at holiday edges. Spontaneous holidays may also be caused by such potentials. This test method provides accelerated conditions for cathodic disbondment to occur and provides a measure of resistance of coatings to this type of action.

4.2 The effects of the test are to be evaluated by physical examinations and monitoring the current drawn by the test specimen. Usually there is no correlation between the two methods of evaluation, but both methods are significant. Physical examination consists of assessing the effective contact of the coating with the metal surface in terms of observed differences in the relative adhesive bond. It is usually found that the cathodically disbonded area propagates from an area where adhesion is zero to an area where adhesion reaches the original level. An intermediate zone of decreased adhesion may also be present.

4.3 Assumptions associated with test results include:

4.3.1 Maximum adhesion, or bond, is found in the coating that was not immersed in the test liquid, and

4.3.2 Decreased adhesion in the immersed test area is the result of cathodic disbondment.

4.4 Ability to resist disbondment is a desired quality on a comparative basis, but disbondment in this test method is not necessarily an adverse indication of coating performance. The virtue of this test method is that all dielectric-type coatings now in common use will disbond to some degree, thus providing a means of comparing one coating to another.

4.5 The current density appearing in this test method is much greater than that usually required for cathodic protection in natural environments.

4.6 That any relatively lesser bonded area was caused by electrical stressing in combination with the elevated and or depressed temperature and was not attributable to an anomaly in the application process. Ability to resist disbondment is a desired quality on a comparative basis, but most insulating materials will disbond to some extent under the accelerated conditions of this test. Bond strength is more important for proper functioning of some coatings than others and the same measured disbondment for two different coating systems may not represent equivalent loss of corrosion protection.

4.6.1 The amount of current flowing in the test cell may be a relative indicator of the extent of areas requiring protection against corrosion; however, the current density appearing in this test is much greater than that usually required for cathodic protection in natural, inland soil environments.

4.6.2 Test voltages higher than those recommended may result in the formation of chlorine gas. The subsequent chemical effects on the coating could cast doubt on the interpretation of the test results.

5. Apparatus

5.1 *Test Vessel*—A suitable nonreactive vessel shall be used, capable of withstanding internal heating at not less than 60°C and suitable for continuous circulation of the electrolyte. A19-L (5-gal) cylindrical glass vessel has been found suitable, having an approximate diameter of 300 mm (12 in.) and a depth of 300 mm. A flat bottom is required for operation of a magnetic stirring rod. An alternate means of heating the test sample can be provided by internally heating. The pipe sample may be filled with a suitable heat transfer material (oil, steel shot, etc). A thermocouple or thermometer and heater can be immersed in the heat transfer medium to effectively control the temperature of the sample. Dimensions of the vessel shall permit the following requirements:

5.1.1 Test specimens shall be suspended vertically in the vessel with at least 25 mm (1 in.) clearance from the bottom.

5.1.2 Test specimens shall be separated by not less than 38 mm (1½ in.), and a vertically suspended anode can be placed at an equal distance from each specimen not less than the separation distance.

5.1.3 Test specimens shall be separated from any wall of the vessel by not less than 13 mm (½ in.).

5.1.4 Depth of electrolyte shall permit the test length of the specimen to be immersed as required in 7.4.

5.1.5 The reference electrode may be placed anywhere in the vessel, provided it is separated from the specimen and from the anode by not less than 38 mm (1½ in.).

5.2 *Anode*—The anode shall be provided with a factory-sealed, insulated copper wire lead.³

5.3 *Connectors*—Wiring from anode to test specimen shall be 4107 cmil (14-gage Awg), minimum, insulated copper. Attachment to the test specimen shall be by soldering or brazing to the nonimmersed end, and the place of attachment shall be coated with an insulating material. A junction in the connecting wire is permitted, provided that it is made by means of a bolted pair of terminal lugs soldered or mechanically crimped to clean wire ends.

5.4 *Holiday Tools*—Holidays shall be made with conventional drills of the required diameter. For use in preparing small-diameter pipe specimens such as 19-mm (¾-in.) nominal diameter pipe, the use of a drill modified by substantially grinding away the sharp cone point has been found effective in preventing perforation of the metal wall of the pipe. A sharp-pointed knife with a safe handle is required for use in making physical examinations.

5.5 *Multimeters:*

5.5.1 *Multimeter*, for direct current, having an internal resistance of not less than 10 MΩ and having a range from 0.01 to 5 V for measuring potential to the reference electrode.

5.5.2 *Multimeter*, for direct current, having an internal resistance of not less than 11 MΩ and capable of measuring as low as 10 μV potential drop across a shunt in the test cell circuit.

5.5.3 *Multimeter*, for initial testing of apparent coating resistance.

5.6 *Reference Electrode*—Saturated Cu CuSO₄ electrode having a potential of -0.316 V with respect to the standard hydrogen electrode shall be the standard of reference in these test methods. Other electrodes may be used but measurements thus obtained shall be converted to the Cu CuSO₄ reference for reporting by making the proper correction.

NOTE 1—A saturated Cu CuSO₄ electrode reading -1.50 V at 25°C will read -1.53 V at 60°C, a scale increase of 0.03 V.

5.6.1 A saturated calomel electrode at 25°C is converted to Cu CuSO₄ by adding -0.07 V to the observed reading. If the saturated calomel electrode reads -1.43 V at 25°C, it will read -1.46 V at 60°C, a scale increase of 0.03 V. It follows that a saturated calomel electrode reading of -1.46 V at 60°C is equal to a saturated Cu CuSO₄ reading of -1.50 V at 25°C.

5.6.2 A 0.1 normal calomel electrode at 25°C is converted to Cu CuSO₄ by subtracting -0.02 V from the observed reading. Since the potential change due to an increase from 25°C to 60°C is negligible, it follows that a 0.1 normal calomel electrode reading -1.52 V at 60°C is equal to a saturated Cu CuSO₄ reading of -1.50 V at 25°C.

5.7 *Thermometers*, two, mercury-filled type, accurate to ±1°C. One shall be of the full-immersion type for measuring temperature near the bottom of the vessel, and a second

³ Duriron, a material found suitable for this purpose is available from Duriron Co., Inc., Dayton, OH.

thermometer shall be of the partial-immersion type for measuring temperature near the top of the vessel.

5.8 *Combination Heater Plate*, with built-in magnetic stirrer, or equivalent, shall be used for heating and stirring the electrolyte. The heater shall be adjustable to produce and control a temperature of $60 \pm 1^\circ\text{C}$ in the test vessel.

5.9 *Direct-Current Rectifier*, capable of supplying constant current at a voltage of $1.50 \pm 0.01\text{ V}$, as measured between the specimen and reference cell.

5.10 *Thickness Gage*, for measuring coating thickness in accordance with Test Method G 12.

5.11 *Precision Resistor*, $1\Omega \pm 1\%$, 1 W (min), to be used in the test cell circuit as a shunt for current.

5.12 *Carbon or Stainless Steel Electrode*, used temporarily with the volt-ohm-meter to determine apparent initial holiday status of the test specimen.

5.13 *Additional Connecting Wires*, 4107 cmil (14-gage Awg), minimum, insulated copper.

5.14 *Brass Studs*, used at a terminal board, together with alligator clips or knife switches, for making and breaking circuits. Alligator clips shall not be used to connect the electrodes or specimens at the top location of test cells.

6. Reagents and Materials

6.1 The electrolyte shall consist of potable tap water or

materials, including molded elastomeric or plastic end caps, capable of withstanding the test temperature.

6.3 Plywood has been found suitable for the construction of nonconductive test vessel covers and for the support through apertures of test specimens and electrodes. Wood dowels introduced through holes in the top ends of specimens have been found suitable for suspending test specimens from the vessel cover.

7. Test Specimen

7.1 The test specimen shall be a representative piece of production-coated pipe. One end shall be plugged, sealed, or capped.

7.2 One holiday shall be made in the middle of the immersed length by drilling a radial hole through the coating so that the angular cone point of the drill will fully enter the steel where the cylindrical portion of the drill meets the steel surface. The drill diameter shall be not less than three times the coating thickness, but it shall never be less than 6 mm ($\frac{1}{4}\text{ in.}$) in diameter. The steel wall of the pipe shall not be perforated. With small-diameter pipes, where there is danger of perforating the pipe, the holiday shall be started with a standard 60° cone point and finished with a drill that has had a substantial portion of the cone point ground away.

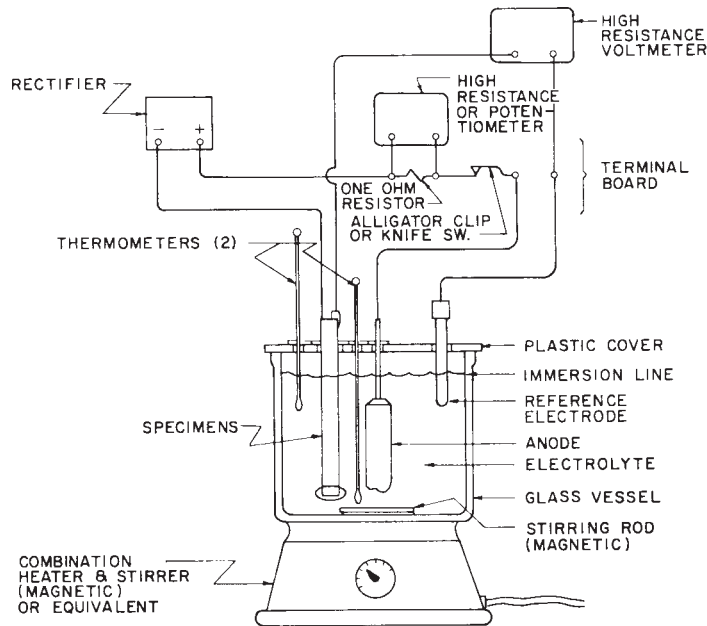

NOTE 1—For multiple specimens in the same test vessel, see Fig. 2, for circuit diagram using voltage dividers.

FIG. 1 Test Set-Up for Cathodic Disbonding Test at Elevated Temperature

higher purity water (distilled or demineralized water is satisfactory) with the addition of 1 weight % of each of the following technical-grade salts, calculated on an anhydrous basis: sodium chloride, sodium sulfate, and sodium carbonate.

NOTE 2—The resulting solution has a pH of 10 or higher and a resistivity of 25 to 50 $\Omega\text{-cm}$ at room temperature.

6.2 Materials for sealing the ends of coated pipe specimens may consist of bituminous products, wax, epoxy, or other

NOTE 3—Before making the holiday, see 7.5.

7.3 The end of the pipe which will protrude above the immersion line shall be provided with suitable supporting means and a separate wire connection for electrical purposes, soldered, or brazed to the pipe. The protruding end, including hanger and wire connections, shall be protected and sealed with an insulating coating material.

7.4 The specimen test area shall consist of the area between the edge of the bottom end seal and the immersion line. The bottom end seal area shall not be considered part of the area tested. Coated specimens of any suitable diameter and length of pipe may be used, but the immersed area shall be not less than 23 200 mm² (36 in.²). An area of 92 900 mm² (1 ft²) has been found preferable when convenient.

7.5 The continuity of the coating and efficiency of the end seal shall be tested before making artificial holidays as follows:

7.5.1 Immerse the test specimen and a carbon or stainless steel electrode in the electrolyte. Connect one terminal of the ohmmeter to the test specimen and the other terminal to the carbon or stainless steel electrode. Measure the apparent resistance in ohms, making two determinations: one with the specimen connected to the positive terminal of the ohmmeter, and one with the specimen connected to the negative terminal. The lowest of the two readings should be not less than 1000 MΩ, however, the test may be conducted with a low reading less than 1000 MΩ, provided that the condition is taken into account in evaluating results.

8. Procedure

8.1 Immerse the test specimen in the electrolyte and connect it to the anode as shown in Fig. 1. Adjust the rectifier or voltage divider so that the potential between specimen and reference cell is -1.50 ± 0.01 V at 25°C (-1.53 ± 0.01 V at 60°C) (see Fig. 2). The holiday may be positioned facing the anode or facing away from the anode as described in Test Methods G 8. Space the anode with respect to test specimens as required in 5.1. Mark the correct immersion level on the exterior of the test

vessel and maintain by daily additions of preheated, distilled, or demineralized water as required.

8.2 When using the electrolyte heating methods the temperature of the electrolyte surface to bottom shall be not less than 60 ± 3 °C. The electrolyte shall be continuously circulated by means of the stirring apparatus or equivalent. The maximum temperature shall be attained 4 ± 1 h after starting the heater and immersing the specimen.

NOTE 4—Throughout the test period, ejected sealant or salt deposits, or both, may form near, or partially obstruct the intentional coating holiday described in 7.2. No attempt shall be made to clear the holiday while the test is in progress.

8.3 Electrical Monitoring Schedule:

8.3.1 Electrical measurements shall be made on the start-up day and on each normal working day thereafter for the duration of the test. A maximum of three consecutive nonworking days shall be preceded by at least two working days; one non-working day or two consecutive non-working days shall be preceded by at least one working day, except at start-up and termination when three and two working days are required, respectively.

8.3.2 Electrical measurements characterizing the start of the test are defined as the average of measurements taken on the second and third days after immersion.

8.3.3 Electrical measurements characterizing intermediate and terminal time spans shall be taken on two successive days prior to and including the target date.

8.4 Electrical measurements and adjustments made each normal working day:

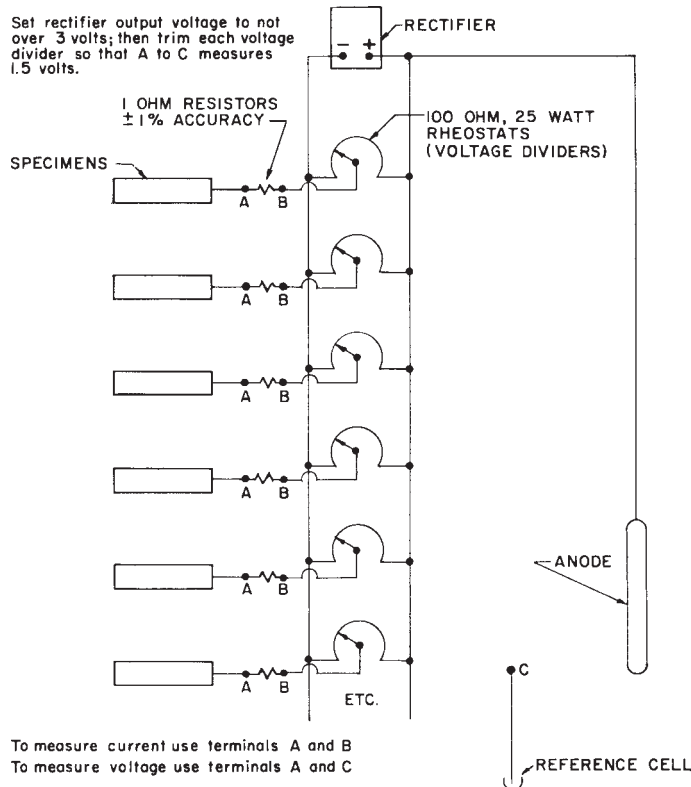

FIG. 2 Circuit Diagram for Cathodic Disbonding Test

8.4.1 Measure E_2 , the stress potential in volts between the test specimen and the reference electrode, without disconnecting the energized anode or specimen from the circuit. Use the high-resistance voltmeter described in 5.5. The stress potential, E_2 , should measure -1.50 ± 0.01 V at 25°C (-1.53 ± 0.01 V at 60°C); if it does not, adjust the rectifier or voltage divider accordingly.

8.4.2 After E_2 has been measured and adjusted, if necessary, measure I_1 , the current demand in amperes, by determining the potential drop across the $1\text{-}\Omega$ precision resistor permanently installed in the test cell circuit with the high-resistance voltmeter described in 5.2. The voltage reading will be numerically equal to amperes.

NOTE 5—An alternative method of measuring current demand utilizes a zero-resistance ammeter. In this method, the wire connection between the test specimen and anode is temporarily broken and a zero-resistance ammeter temporarily interposed between the specimen and the anode. Reconnect the specimen to the anode with the connector wire as soon as this measurement is completed.

8.4.3 Measure E_1 , the polarized potential, in volts, using the high-resistance voltmeter described in 5.5 connected between the test specimen and the reference electrode as follows:

8.4.3.1 Disconnect the anode from the test specimen while closely observing the high-resistance voltmeter. As the instrument pointer falls, it will dwell significantly at the polarized potential before recording further. The dwell point is E_1 .

8.5 Standard duration of the test period shall be 30 days (720 h) in the energized test vessel including warm-up and cool-down times, unless longer test periods are specified.

8.6 A physical examination shall be performed immediately upon termination of the test period as follows:

8.6.1 Before examination, wash the test specimen carefully under gently flowing tap water without disturbing visible destructive effects. Adjust the temperature of the tap water so that it approximates that of the room temperature.

8.6.2 Examine the entire immersed area visually for any evidence of new holidays and loosening of coating at the edge of all holidays, including the artificial holiday.

8.6.3 Drill a new test hole in the coating in an area that was not immersed, staying away from the immersion line and the cut end. Recommended distances are given in Fig. 3. Follow the same drilling procedure described in 7.2.

8.6.4 In order to gage or calibrate the lifting technique, attempt to lift the coating at the new test hole with the point of a sharp knife after making cuts through the coating intersecting at the center of the hole. Inability or relative resistance to lifting or disbonding the coating shall be considered the adhered or bonded condition of the untested coating with respect to the lifting technique used.

8.6.5 Determine if the coating has been loosened at the immersed test hole by attempting to lift the coating with the point of a sharp knife after making cuts through the coating intersecting at the holiday or point of inspection using the same technique applied in 8.6.4. Classify coating that can be lifted or disbonded more readily than at the new test hole as unsealed area. Measure the unsealed area.

NOTE 6—The use of a transparent film having a grid laid out in small squares such as 2.54 mm (0.1 in.) on a side has been found useful. The

film is placed against the unsealed area and the boundary of the unsealed area is traced on the grid. The area is then obtained by counting the squares within the bounded area.

8.7 Determine and record the resistivity and pH of the electrolyte at the beginning and end of the test period.

9. Report

9.1 The report shall include the following information (see Fig. 4):

9.1.1 Complete identification of the test specimen, including:

9.1.1.1 Name and code number of the coating,

9.1.1.2 Size of pipe,

9.1.1.3 Source, production date, and production run number,

9.1.1.4 Minimum-maximum coating thickness,

9.1.1.5 Immersed area,

9.1.1.6 Size and number of initial holidays, and

9.1.1.7 Dates of starting and terminating test.

9.1.2 The relative resistances of the test specimen, in ohms, before the artificial holiday was made as described in 7.5.

9.1.3 Tally of areas that have been found unsealed on the terminal date. Areas may be reported in square millimetres (or square inches) or millimetres (or inches) of equivalent circle diameter of the area, or both.

9.1.4 The results of starting, intermediate, and terminal electrical measurements. Report the following measurements:

9.1.4.1 Current demand in microamperes or negative characteristic of the logarithm of the current in amperes, in both,

9.1.4.2 The value of $\Delta E = E_2 - E_1$, in volts, and

9.1.4.3 Change from start to termination for values in 9.1.4.1 and 9.1.4.2.

9.1.5 Temperature of the electrolyte at approximately the same hour each working day.

9.1.6 Other information that may be pertinent.

10. Precision and Bias

10.1 Precision data are limited to two adjacent specimens taken from the same production-coated pipe and assumed that the production process was uniform with respect to pipe surface condition and coating material. Specimens that were not adjacent in the as-produced condition or were taken from different lengths of pipe may represent differing process conditions. The following data should be used for judging the acceptability of results. (These precision data are approximations based on limited data, but they provide a reasonable basis for judging the significance of results.)

10.2 *Repeatability*—Duplicate results obtained within a laboratory should be acceptable unless they differ by more than 25 mm (1 in.) in value D in accordance with the following equation:

$$D = (A/0.785)^{1/2}$$

where:

A = unsealed area developed from one artificial holiday, mm^2 (or in.^2)

or if they differ by more than unity in the negative characteristic of the logarithm of the current demand in amperes.

10.3 *Reproducibility*—The results reported by one laboratory should be acceptable unless they differ from those of

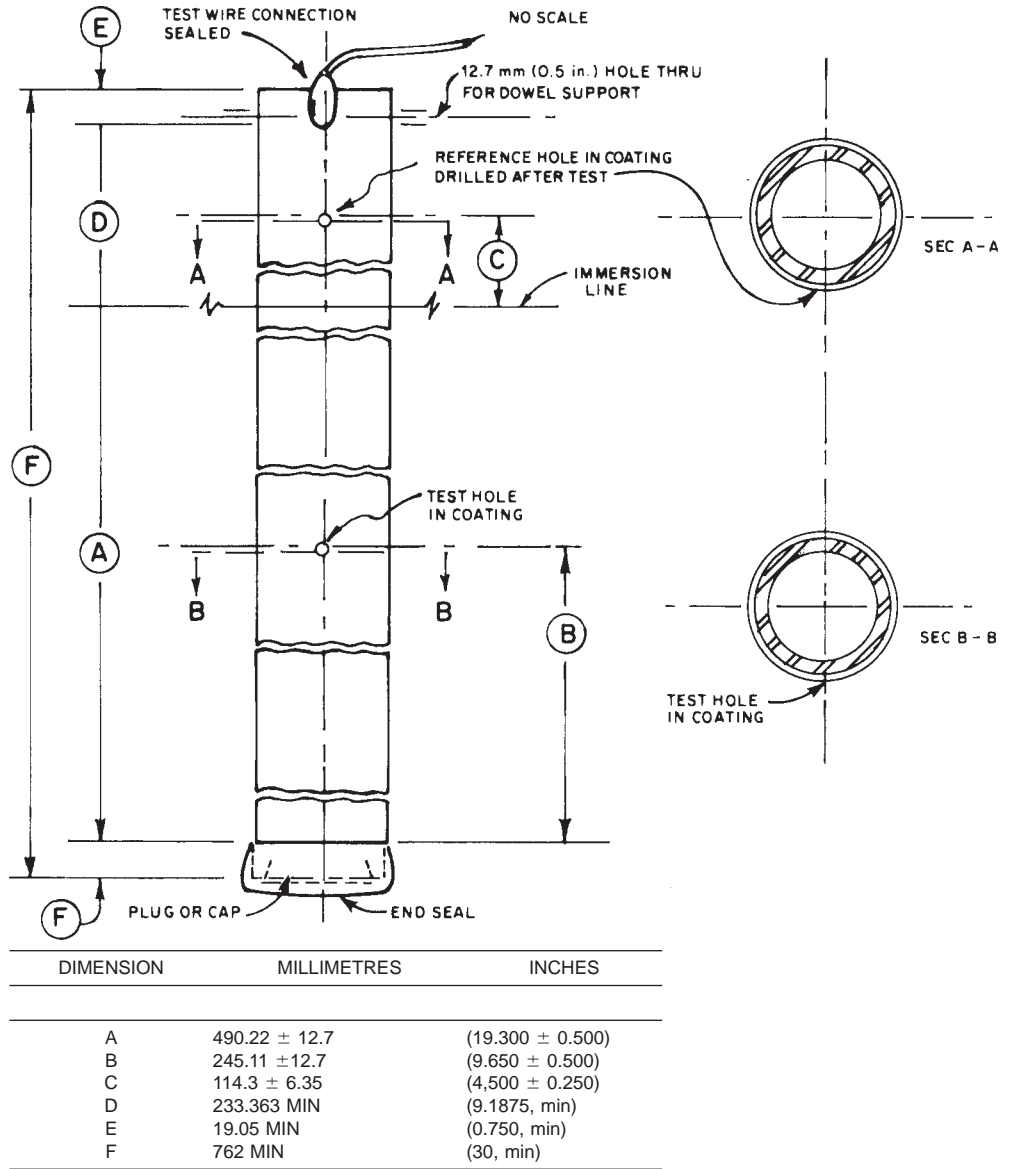

FIG. 3 Recommended Dimensions for Specimen

another laboratory by more than 25 mm (1 in.) for the value *D* in the equation given in 10.2, and by more than unity in the negative characteristic of the logarithm of the current demand in amperes.

10.3.1 When comparing test results from different laboratories, the same heating method of the samples should be used.

11. Keywords

11.1 cathodic disbonding; elevated temperature; pipeline coatings

ASTM International takes no position respecting the validity of any patent rights asserted in connection with any item mentioned in this standard. Users of this standard are expressly advised that determination of the validity of any such patent rights, and the risk of infringement of such rights, are entirely their own responsibility.

This standard is subject to revision at any time by the responsible technical committee and must be reviewed every five years and if not revised, either reapproved or withdrawn. Your comments are invited either for revision of this standard or for additional standards and should be addressed to ASTM International Headquarters. Your comments will receive careful consideration at a meeting of the responsible technical committee, which you may attend. If you feel that your comments have not received a fair hearing you should make your views known to the ASTM Committee on Standards, at the address shown below.

This standard is copyrighted by ASTM International, 100 Barr Harbor Drive, PO Box C700, West Conshohocken, PA 19428-2959, United States. Individual reprints (single or multiple copies) of this standard may be obtained by contacting ASTM at the above address or at 610-832-9585 (phone), 610-832-9555 (fax), or service@astm.org (e-mail); or through the ASTM website (www.astm.org).