



Standard Test Methods for Softening Point of Resins Derived from Naval Stores by Ring-and-Ball Apparatus¹

This standard is issued under the fixed designation E 28; the number immediately following the designation indicates the year of original adoption or, in the case of revision, the year of last revision. A number in parentheses indicates the year of last reapproval. A superscript epsilon (ϵ) indicates an editorial change since the last revision or reapproval.

This standard has been approved for use by agencies of the Department of Defense.

1. Scope

1.1 These test methods are intended for determining the softening point of resins (including rosin and terpene resins) and similar materials by means of the ring-and-ball apparatus.

NOTE 1—For testing asphalts, tars, and pitches, see Test Methods D 36.

1.1.1 Test method using the manual ring and ball softening point apparatus, and

1.1.2 Test method using an automated ring and ball softening point apparatus.

1.2 The values stated in SI units are to be regarded as the standard. The values given in parentheses are for information only.

1.3 *This standard does not purport to address all of the safety concerns, if any, associated with its use. It is the responsibility of the user of this standard to establish appropriate safety and health practices and determine the applicability of regulatory limitations prior to use.*

2. Referenced Documents

2.1 *ASTM Standards:*

D 36 Test Method for Softening Point of Bitumen (Ring and Ball Apparatus)²

E 1 Specification for ASTM Thermometers³

E 177 Practice for Use of Terms Precision and Bias in ASTM Test Methods⁴

E 691 Practice for Conducting an Interlaboratory Study to Determine the Precision of a Test Method⁴

3. Significance and Use

3.1 In general, with materials of these types, softening does not take place at a definite temperature. As the temperature rises, these materials gradually change from brittle or exceedingly thick and slow-flowing materials to softer and less viscous liquids. For this reason, the determination of the

softening point must be made by a fixed, arbitrary, and closely defined method if the results obtained are to be comparable.

3.2 In these test methods, the softening point is defined as the temperature at which a disk of the sample held within a horizontal ring is forced downward a distance of 25.4 mm (1 in.) under the weight of a steel ball as the sample is heated at 5°C/min in a water, glycerin, silicone oil, ethylene glycol/water or glycerin/water bath.

4. Sample Preparation

4.1 *Preparation of Sample by the Pour Method:*

4.1.1 This procedure is suitable for materials that can be heated and poured without adverse effects on the softening point.

4.1.2 Select a sample representative of the material to be tested. The sample should consist of flakes, pastilles, or freshly broken lumps free of oxidized surfaces. Avoid inclusion of finely divided material or dust.

4.1.3 Select a quantity at least twice that necessary to fill the desired number of rings, and melt it immediately in a clean container, using an oven, hot plate, sand bath or oil bath to prevent local overheating. Take care to avoid incorporating air bubbles in the sample. Melt the sample completely, but do not heat it above a temperature necessary to pour the material readily. The time from the beginning of heating to the pouring of the sample should not exceed 15 min.

NOTE 2—For materials that may be heat sensitive, continuously inert the flask containing the test specimen with nitrogen (N_2) during the remelting procedure.

4.1.4 For materials that tend to crack or shrink in the ring on cooling, immediately before filling the ring, preheat the ring to approximately the temperature at which the material is to be poured. The ring, while being filled, should rest bottom down on a suitable metal surface. Pour the sample into the ring so as to leave an excess on cooling. After cooling a minimum of 30 min, trim off the excess resin on the periphery of the ring. To remove excess resin from the top, cut the excess material off cleanly with a slightly heated knife or spatula, or grasp the ring in a pair of tongs and draw the top surface quickly and firmly over the surface of a heated metal plate. In case the test is repeated, use a clean container and fresh sample.

4.2 *Preparation of Sample by the Molding Method:*

¹ These test methods are under the jurisdiction of ASTM Committee D-1 on Paint and Related Coatings, Materials, and Applications and is the direct responsibility of Subcommittee D01.34 on Naval Stores.

Current edition approved Dec. 10, 1999. Published February 2000. Originally published as E 28 – 36 T. Last previous edition E 28 – 97.

² *Annual Book of ASTM Standards*, Vol 04.04.

³ *Annual Book of ASTM Standards*, Vol 14.03.

⁴ *Annual Book of ASTM Standards*, Vol 14.02.

4.2.1 See Appendix X1, Alternate Sample Preparation Procedures.

4.3 *Preparation of Samples Having a Low Softening Point (up to 35°C (95°F)):*

4.3.1 Place a ring on a piece of aluminum foil. Pour the material to be tested into the ring, then place the foil and filled ring on dry ice or in a freezer to cool. The material in the ring must be free of bubbles.

4.3.2 After cooling, cut and scrape off any excess material using a slightly heated spatula, then slide the ring gently from the foil. Place the ring in the supporting apparatus, and immediately perform the softening point analysis according to Section 11.

5. Reagents and Materials

5.1 Bath Liquids:

5.1.1 *Distilled or Deionized Water, Freshly Boiled*—For softening points between 35°C (95°F) and 80°C (176°F).

5.1.1.1 Use distilled or deionized water that has been cooled to at least 27°C (81°F) below the anticipated softening point, but in no case lower than 5°C (41°F).

5.1.2 *USP Glycerin*—For softening points between 80°C (176°F) and 150°C (302°F). Repeated use of glycerin will increase the moisture content over time and may affect results. Replace with fresh glycerin if any change in appearance is noted.

NOTE 3—Glycerin should not be used for softening points greater than 150°C (302°F) due to the 160°C (320°F) flash point of glycerin.

5.1.3 *Silicone Oil (Polydimethylsiloxane)*—For softening points above 80°C (176°F). The silicone oil must have a temperature range of 200°C + (392°F), remain clear within the temperature range, have no apparent reactivity with the test specimen, have a high water repellency, and maintain a uniform viscosity and stirring rate within the temperature range.⁵

NOTE 4—Replace with fresh silicone oil if any change in appearance is noted. Do not use silicone oil that contains any gels; gels are an indicator that degradation has occurred.

5.1.4 *Ethylene Glycol*—For softening points up to 35°C (95°F).

5.1.4.1 Prepare a fresh 50/50 (v/v) mixture of distilled water and ethylene glycol prior to sample analysis. For softening points between 0°C and 35°C, a 50/50 (v/v) mixture of glycerin and water may be used.

MANUAL RING AND BALL SOFTENING POINT METHOD

6. Apparatus

6.1 *Ring and Ball Apparatus*, consisting of the following:

6.1.1 *Ring*—A brass, shouldered ring conforming to the dimensions shown in Fig. 1(a).

6.1.2 *Ball*—A steel ball, 9.53 ± 0.1 mm ($\frac{3}{8}$ in.) in diameter, weighing between 3.45 and 3.55 g.

6.1.3 *Ball-Centering Guide*—A brass guide for centering the ball conforming to the general shape and dimensions shown in Fig. 1(c), the use of which is optional.

6.2 *Support for Ring and Thermometer*—Any convenient method for supporting the ring and thermometer may be used, provided it meets the following requirements:

6.2.1 The ring must be supported in a substantially horizontal position.

6.2.2 When using the apparatus shown in Fig. 1(d): The bottom of the ring must be 25.4 ± 0.2 mm (1.0 in.) above the horizontal plate below it; the bottom surface of the horizontal plate must be 12.7 to 19.05 mm (0.5 to 0.75 in.) above the bottom of the beaker.

6.2.3 Suspend a thermometer so that the bottom of the bulb is level with the bottom of ring and within 12.7 mm (0.5 in.) but not touching the ring or the ring holder.

6.3 *Bath*—A heat-resistant glass beaker, at least 85 mm (3.34 in.) in diameter and 127 mm (5 in.) in depth from the bottom of the flare, for example, an 800-mL low-form Griffin beaker.

6.4 *Temperature Measuring Device*—A thermometer having a range described below and conforming to the requirements prescribed in Specification E 1, or an electronic temperature measuring device, such as a resistance thermometer or thermocouple. The device must exhibit the same temperature response as the thermometers specified in Specification E 1 and must be accurately calibrated.

6.4.1 An ASTM Thermometer, having a range from -38 to $+50$ °C (-36 to $+120$ °F), ASTM 5C, 5F, or equivalent.

6.4.2 An ASTM Low-Softening-Point Thermometer, having a range from -2 to 80 °C (30 to 180°F), ASTM 15C, 15F or equivalent.

6.4.3 An ASTM Medium-Softening Point Thermometer, having a range from 30 to 200°C (85 to 392°F), ASTM 16C, 16F or equivalent.

6.4.4 An ASTM High-Softening-Point Thermometer, having a range from -2 to 300°C (30 to 580°F), ASTM 7C, 7F or equivalent.

6.5 *Stirrer*—The heating bath must be stirred at a speed sufficient to ensure uniform heat distribution without causing significant sideways displacement of the resin as it softens in the ring. A stirring rate of 500 to 700 r/min is typical. A mechanical motor-driven stirrer, mounted so that any vibrations created by its rotation are not conveyed directly to the sample support, or a magnetic stirrer placed under the bath may be used.

6.6 *Heat Source*—A heat source capable of maintaining the proper heating rate, such as a temperature controller with immersion heating coil, an electric heater or a bunsen burner.

7. Procedure for Materials Having a Softening Point Between 35 and < 80°C (95 and 176°F)

7.1 *Assembly of Apparatus*—Fill the bath with distilled or deionized water, conforming to the requirements in 5.1.1, so that the level will be 105 ± 3 mm (4.13 ± 0.12 in.). If a mechanical motor-driven stirrer is used, position the axis of the stirrer shaft near the back wall of the beaker, with the blades

⁵ The sole source of supply of silicone oil, 200 fluid, 50 cSt viscosity known to the committee at this time is Dow Corning Corp., Midland, MI 48686. If you are aware of alternative suppliers, please provide this information to ASTM Headquarters. Your comments will receive careful consideration at a meeting of the responsible technical committee,¹ which you may attend.

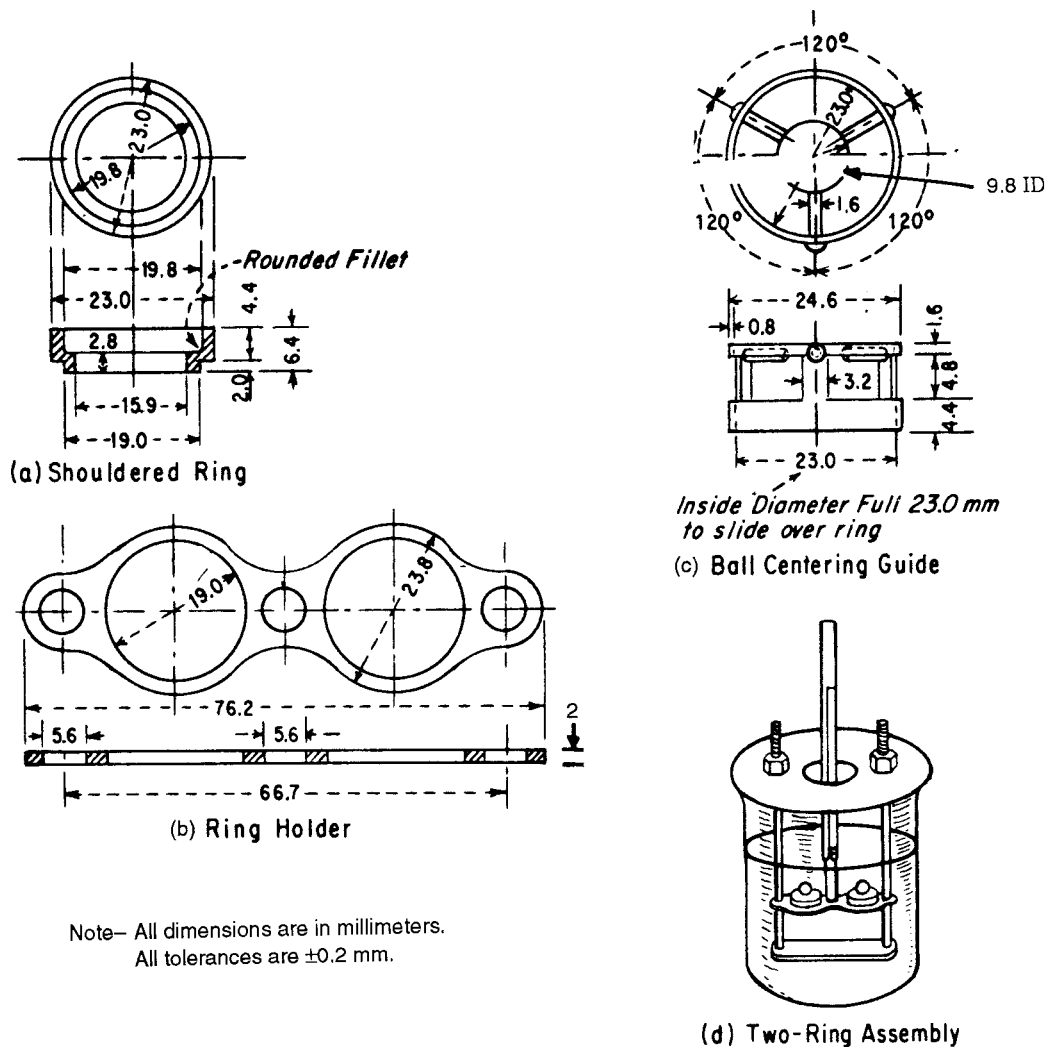

FIG. 1 Shouldered Ring, Ring Holder, Ball-Centering Guide, and Assembly of Apparatus Showing Two Rings

clearing the wall and with the bottom of the blades approximately 19.0 mm (0.75 in.) above the top of the ring. If the ball-centering guide is not used, make a slight indentation in the center of the sample by pressing the ball or a rounded rod, slightly heated for hard materials, into the material at this point. Suspend the ring containing the sample in the water in the manner described in 6.2.2 or 25.4 ± 0.2 mm (1 in.) above the bottom of the beaker when using the apparatus in Fig. 2(e). Center the ball on the surface of the test specimen in the ring. Suspend an ASTM low-softening-point thermometer in the bath as prescribed in 6.2.3. Maintain the initial temperature of the water for 15 min. Start stirring, and continue stirring until completion of the determination.

7.2 Heating—Heat the bath so that the temperature of the water is raised uniformly at a rate of 5°C (10°F)/min. Protect the bath from drafts, using shields if necessary. Do not average the rate of rise over the test period. The maximum permissible variation for any 1-min period after the first three minutes is $\pm 0.5^{\circ}\text{C}$ ($\pm 1^{\circ}\text{F}$). Reject any test in which the rate of temperature rise does not fall within these limits.

NOTE 5—Rigid adherence to the prescribed rate of heating is absolutely essential for reproducibility of results.

7.3 Softening Point—Record as the softening point the temperature of the thermometer at the instant the material touches the lower horizontal plate (Fig. 1(d)). Make no correction for the emergent stem of the thermometer.

NOTE 6—When the ball drops through the ring, it should be completely surrounded by softening resin and should drop straight down to the lower horizontal plate.

7.4 Thoroughly clean the ring holder, ball, and ring in a suitable solvent.

8. Calibration

8.1 A calibration check of any temperature controllers used in the manual ring and ball softening point apparatus must be performed on a regular basis since accurate temperature control is required.

9. Procedure for Materials Having Softening Points Between 80°C (176°F) and 150°C (302°F)

9.1 Use the same procedure as described in Section 8, except fill the bath with glycerin or silicone oil (Note 3) and use an ASTM medium-softening-point thermometer. The maximum allowable starting temperature of the bath is the

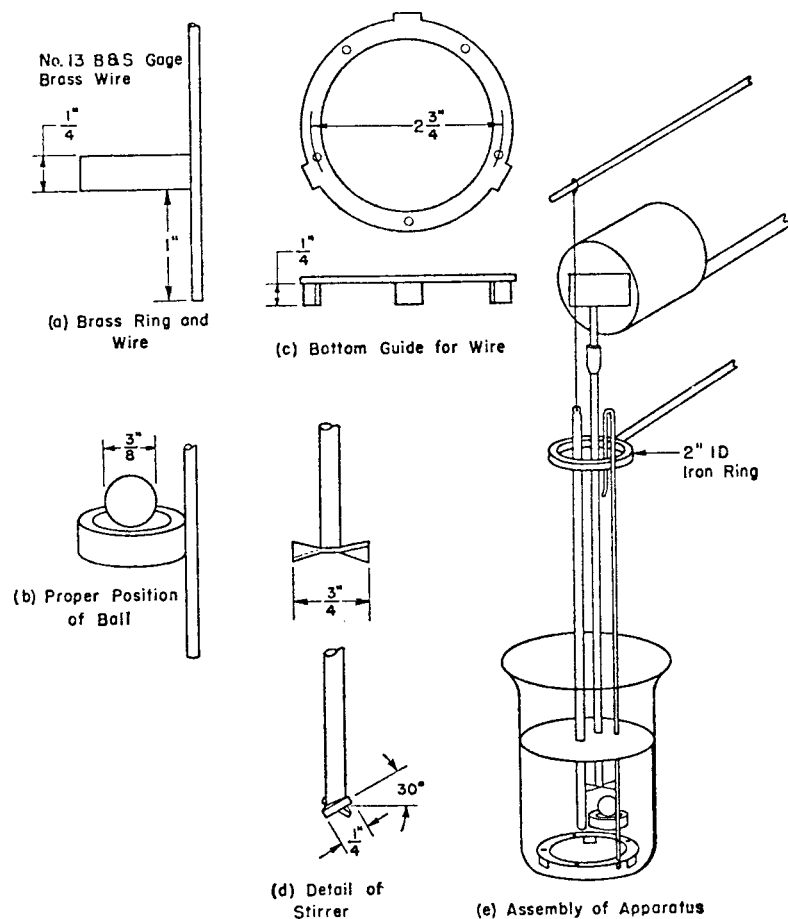

FIG. 2 Assembly of Apparatus Showing Stirrer and Single Shouldered Ring

lower of: (a) 27°C (81°F) below the anticipated softening point, or (b) 32°C (90°F).

NOTE 7—For materials softening around 80°C (176°F) report the bath liquid since a glycerin or silicone oil bath will yield a slightly higher result than a water bath.

NOTE 8—Repeated use of glycerin will increase the moisture content over time and may affect results. Replace with fresh glycerin if any change in appearance is noted.

10. Procedure for Materials Having Softening Points Above 150°C (302°F)

10.1 Use the same procedure as described in Section 9, except fill the bath with silicone oil (Note 4) and use an ASTM high-softening-point thermometer.

11. Procedure for Materials Having Softening Points Below 35°C (95°F)

11.1 Apparatus:

11.1.1 Isopropyl Alcohol Dry-Ice Bath.

11.2 Procedure:

11.2.1 Cool the bath, described in 5.1.4.1, to -25°C (-13°F) in an isopropyl alcohol dry-ice bath.

11.2.2 Use the same procedure as in Section 9 except for the bath liquid, and immediately begin heating as directed once the test specimen in the ring has been placed in the bath.

AUTOMATED RING AND BALL SOFTENING POINT METHOD

12. Apparatus

12.1 Automated Ring and Ball-Softening Point Instrument with Control Unit, test units, and test inserts.

12.2 Ring—A brass, shouldered ring conforming to the dimensions shown in Fig. 1(a).

12.3 Ball—A steel ball, 9.53 ± 0.1 mm ($\frac{3}{8}$ in.) in diameter, weighing between 3.45 and 3.55 g.

12.4 Beaker, 600 mL. Ensure that the dimensions will properly fit the heating unit.

12.5 Stir Bar—The dimensions must be such that the bar spins freely under the test stand.

13. Procedure for Materials Having a Softening Point Between 35°C (95°F) and <80°C (176°F)

13.1 Add a stir bar to the 600-mL beaker and fill with approximately 500 mL of distilled or deionized water, conforming to the requirements in 5.1.1. Ensure that the beaker is properly positioned on the heater in the test unit. Place the prepared sample rings in the test insert. Place the ball-centering guide and ball on top of the sample ring. Place the test insert in the beaker of water, suspending it from the support pins. Place the temperature measuring device in the test insert. Verify that the control unit is set for the correct bath liquid.

13.2 *Heating*—Heat the bath so that the temperature of the water is raised uniformly at a rate of 5°C (10°F)/min. Protect the bath from drafts, using shields if necessary. The maximum permissible variation for any 1-min period after the first three min is $\pm 0.5^\circ\text{C}$ ($\pm 1^\circ\text{F}$). Reject any test in which the rate of temperature rise does not fall within these limits. The test is complete when the light beam has been interrupted by the falling ball and material.

NOTE 9—Rigid adherence to the prescribed rate of heating is absolutely essential for reproducibility of results.

13.3 *Softening Point*—Record as the softening point the temperature displayed on the unit after the light beam has been interrupted by the falling ball and material.

13.4 Start the cooling process in the instrument. Remove the temperature measuring device from the test insert, then remove the test insert from the beakers. Thoroughly clean the test insert, ball, and ring in a suitable solvent.

14. Calibration

14.1 The calibration of any automated ring and ball-softening point apparatus must be performed on a regular basis since accurate temperature control is required. Follow the manufacturer's instructions for calibration of the instrument.

15. Procedure for Materials Having Softening Points Between 80°C (176°F) and 150°C (302°F)

15.1 Use the same procedure as described in Section 14, except fill the bath with glycerin or silicone oil.

NOTE 10—For materials softening around 80°C (176°F), report the bath liquid since a glycerin or silicone oil bath will yield a slightly higher result than a water bath.

16. Procedure for Materials Having Softening Points Above 150°C (302°F)

16.1 Use the same procedure as described in Section 13, except fill the bath with silicone oil (Note 3).

17. Report

17.1 Report the softening point to the nearest 1.0°C.

17.2 Report the bath liquid used in the test.

18. Precision and Bias

18.1 *Manual Method Precision*—An interlaboratory study of the ring and ball-softening point of rosin and three resins was run in 1995 by 9 laboratories. The design of the experiment, similar to that of Practice E 691, and a within-between analysis of the data are given in ASTM Research Report No. D01-1113.⁶

18.1.1 *Test Result*—The precision information given below for ring and ball softening point of rosin at the 75°C level in a water bath, and for resins at the 100 to 140°C level in a glycerin or silicone oil bath, respectively, is for the comparison of two test results.

18.1.2 *Precision:*

18.1.2.1 For a material having a 75°C ring and ball softening point run in a water bath:

- | | |
|--|--------|
| (1) <i>Repeatability Limit</i> , 95 % (within laboratory) | = 0.8° |
| (2) <i>Reproducibility Limit</i> , 95 % (between laboratories) | = 5.9° |

18.1.2.2 For a material having a 100 to 140°C ring and ball softening point run in a glycerin or silicone oil bath:

- | | |
|--|--------|
| (1) <i>Repeatability Limit</i> , 95 % (within laboratory) | = 1.2° |
| (2) <i>Reproducibility Limit</i> , 95 % (between laboratories) | = 6.1° |

18.1.2.3 The above terms (repeatability limit and reproducibility limit) are used as specified in Practice E 177. The respective standard deviations among test results, related to the above numbers by the factor 2.8, are:

18.1.2.4 For a material having a 75°C ring and ball softening point run in a water bath:

- | | |
|---|--------|
| (1) <i>Repeatability Standard Deviation</i> | = 0.3° |
| (2) <i>Reproducibility Standard Deviation</i> , | = 2.1° |

18.1.2.5 For a material having a 100 to 140°C ring and ball softening point run in a glycerin or silicone oil bath:

- | | |
|---|--------|
| (1) <i>Repeatability Standard Deviation</i> | = 0.4° |
| (2) <i>Reproducibility Standard Deviation</i> | = 2.2° |

18.2 *Automatic Method Precision*—An interlaboratory study of the ring and ball softening point of three hydrocarbon resins was run in 1998 by 21 laboratories. The design of the experiment, similar to that of Practice E 691, and a within-between analysis of the data are given in ASTM Research Report No. D01-1113.⁶

18.2.1 *Test Result*—The precision information given below for ring and ball softening point of a hydrocarbon resin at the 70°C level in a water bath, and for hydrocarbon resins at the 100 to 135°C level in a glycerin or silicone oil bath, respectively, is for the comparison of two test results.

18.2.2 *Precision:*

18.2.2.1 For a material having a 70°C ring and ball softening point run in a water bath:

- | | |
|--|--------|
| (1) <i>Repeatability Limit</i> , 95 % (within laboratory) | = 0.9° |
| (2) <i>Reproducibility Limit</i> , 95 % (between laboratories) | = 2.4° |

18.2.2.2 For a material having a 100 to 135°C ring and ball softening point run in a glycerin or silicone oil bath:

- | | |
|--|--------|
| (1) <i>Repeatability Limit</i> , 95 % (within laboratory) | = 1.3° |
| (2) <i>Reproducibility Limit</i> , 95 % (between laboratories) | = 3.9° |

18.2.2.3 The above terms (repeatability limit and reproducibility limit) are used as specified in Practice E 177. The respective standard deviations among test results, related to the above numbers by the factor 2.8, are:

18.2.2.4 For a material having a 70°C ring and ball softening point run in a water bath:

- | | |
|---|--------|
| (1) <i>Repeatability Standard Deviation</i> | = 0.3° |
| (2) <i>Reproducibility Standard Deviation</i> , | = 0.9° |

18.2.2.5 For a material having a 100 to 135°C ring and ball softening point run in a glycerin or silicone oil bath:

- | | |
|---|--------|
| (1) <i>Repeatability Standard Deviation</i> | = 0.5° |
| (2) <i>Reproducibility Standard Deviation</i> , | = 1.4° |

18.3 *Bias*—Since there is no accepted reference material, method or laboratory suitable for determining the bias for the procedure in this test method for measuring the ring and ball softening point, no statement on bias is being made.

⁶Supporting data are available from ASTM Headquarters. Request RR:D01-1113.

19. Keywords

19.1 ring and ball; rosin; softening point

APPENDIX

(Nonmandatory Information)

X1. ALTERNATIVE SAMPLE PREPARATION PROCEDURES

X1.1 Preparation of Sample by the Molding Method:

X1.1.1 This sample preparation procedure is suitable for materials that are heat-sensitive and cannot be melted and poured without altering the softening point.

X1.1.2 Apparatus:

X1.1.2.1 Hot Plate.

X1.1.2.2 Aluminum or Steel Plates, 101.6 mm (4 in.) by 152.4 mm (6 in.) by 1.6 mm ($\frac{1}{16}$ in.).

X1.1.2.3 Spatula, 203.2 mm (8 in.), stiff blade.

X1.1.2.4 Tongs.

X1.1.3 Procedure:

X1.1.3.1 Select the sample as described in 4.1.2, then grind superficially in a mortar.

X1.1.3.2 Turn the hot plate to low heat and allow to come to temperature. Place the shouldered ring, bottom down, on one end of the aluminum or steel plate, and then place this assembly on the hot plate. Place 10 to 15 g of the crushed resin on the metal plate so as to form a layer about 6.3-mm ($\frac{1}{4}$ -in.)

thick and 76.2 mm (3 in.) in diameter. The resin adjacent to the metal plate will quickly begin to soften. Using a spatula, scrape and knead the entire mass until it is soft and plastic, using a second spatula if necessary. Finally, gather the entire blob of resin on the spatula, remove the metal plate from the hot plate with a pair of tongs, and quickly press the resin into the shouldered ring, applying pressure to the top of the spatula. Allow the assembly to cool somewhat; then tap the plate and spatula to free the ring. Trim off the excess resin on the periphery of the ring. To remove excess resin from the top, cut the excess material off cleanly with a slightly heated knife or spatula, or grasp the ring in a pair of tongs and draw the top surface quickly and firmly over the surface of a heated metal plate.

X1.1.3.3 Complete this operation within 5 min. Excessive exposure to elevated temperature will promote changes in the sample that result in high softening points.

The American Society for Testing and Materials takes no position respecting the validity of any patent rights asserted in connection with any item mentioned in this standard. Users of this standard are expressly advised that determination of the validity of any such patent rights, and the risk of infringement of such rights, are entirely their own responsibility.

This standard is subject to revision at any time by the responsible technical committee and must be reviewed every five years and if not revised, either reapproved or withdrawn. Your comments are invited either for revision of this standard or for additional standards and should be addressed to ASTM Headquarters. Your comments will receive careful consideration at a meeting of the responsible technical committee, which you may attend. If you feel that your comments have not received a fair hearing you should make your views known to the ASTM Committee on Standards, at the address shown below.

This standard is copyrighted by ASTM, 100 Barr Harbor Drive, PO Box C700, West Conshohocken, PA 19428-2959, United States. Individual reprints (single or multiple copies) of this standard may be obtained by contacting ASTM at the above address or at 610-832-9585 (phone), 610-832-9555 (fax), or service@astm.org (e-mail); or through the ASTM website (www.astm.org).