



Standard Test Method for Skid Resistance of Paved Surfaces Using a Full-Scale Tire¹

This standard is issued under the fixed designation E 274; the number immediately following the designation indicates the year of original adoption or, in the case of revision, the year of last revision. A number in parentheses indicates the year of last reapproval. A superscript epsilon (ϵ) indicates an editorial change since the last revision or reapproval.

1. Scope

1.1 This test method covers the measurement of skid resistance of paved surfaces with a specified full-scale automotive tire.

1.2 This test method utilizes a measurement representing the steady-state friction force on a locked test wheel as it is dragged over a wetted pavement surface under constant load and at a constant speed while its major plane is parallel to its direction of motion and perpendicular to the pavement.

1.3 The values measured represent the frictional properties obtained with the equipment and procedures stated herein and do not necessarily agree or correlate directly with those obtained by other pavement friction measuring methods. The values are intended for use in evaluating the skid resistance of a pavement relative to that of other pavements or for evaluating changes in the skid resistance of a pavement with the passage of time. The values are insufficient to determine the distance required to stop a vehicle on either a wet or a dry pavement. They are also insufficient for determining the speed at which control of a vehicle would be lost, because peak and side force friction are also required for these determinations.

1.4 The values stated in inch-pound units are to be regarded as the standard. The SI values given in parentheses are provided for information only.

1.5 *This standard does not purport to address all of the safety problems associated with its use. It is the responsibility of the user of this standard to establish appropriate safety and health practices and determine the applicability of regulatory limitations prior to use.* For specific safety precautions, see Section 5.

2. Referenced Documents

2.1 ASTM Standards:

E 178 Practice for Dealing with Outlying Observations²

E 501 Specification for Standard Rib Tire for Pavement Skid-Resistance Tests³

E 524 Specification for Standard Smooth Tire for Pavement Skid Resistance Tests³

¹ This test method is under the jurisdiction of ASTM Committee E-17 on Vehicle-Pavement Systems and is the direct responsibility of Subcommittee E17.21 on Field Methods for Measuring Tire Pavement Friction.

Current edition approved Nov. 10, 1997. Published April 1998. Originally published as E 274 – 65T. Last previous edition E 274 – 90 (1997).

² *Annual Book of ASTM Standards*, Vol 14.02.

³ *Annual Book of ASTM Standards*, Vol 04.03.

E 867 Terminology Relating to Traveled Surface Characteristics³

E 1136 Specification for a Radial Standard Reference Test Tire³

F 377 Practice for Calibration of Braking/Tractive Measuring Devices for Testing Tires⁴

F 457 Test Method for Speed and Distance Calibration of a Fifth Wheel Equipped with Either Analog or Digital Instrumentation⁴

3. Summary of Test Method

3.1 The test apparatus consists of an automotive vehicle with one or more test wheels incorporated into it or forming part of a suitable trailer towed by a vehicle. The apparatus contains a transducer, instrumentation, a water supply and proper dispensing system, and actuation controls for the brake of the test wheel. The test wheel is equipped with a standard pavement test tire. See 4.4 for tire references.

3.2 The test apparatus is brought to the desired test speed. Water is delivered ahead of the test tire and the braking system is actuated to lock the test tire. The resulting friction force acting between the test tire and the pavement surface (or some other quantity that is directly related to this force) and the speed of the test vehicle are recorded with the aid of suitable instrumentation.

3.3 The skid resistance of the paved surface is determined from the resulting force or torque record and reported as skid number (SN), which is determined from the force required to slide the locked test tire at a stated speed, divided by the effective wheel load and multiplied by 100.

4. Apparatus

4.1 *Vehicle*—The vehicle with one test tire locked shall be capable of maintaining test speeds of 40 to 60 mph (65 to 100 km/h) within ± 1.0 mph (± 1.5 km/h) during a test on a level pavement having a skid number of 50.

4.2 *Braking System*—The test wheel shall be equipped with a suitable brake. The brake system shall be capable of locking the wheel at the conditions specified in 4.1 and maintaining the locked-wheel condition throughout the test.

4.3 *Wheel Load*—The apparatus shall be of such a design as to provide an equal static load of 1085 ± 15 lbf (4800 ± 65 N) to each test wheel and on detachable trailers a static download

⁴ *Annual Book of ASTM Standards*, Vol 09.02.

of 100 to 200 lbf (450 to 900 N) at the hitch point.

4.4 Tire and Rim—The test tire shall be one of the standard tires for the pavement test as specified in Specification E 501 or E 524, and it shall be mounted on a suitable 15 by 6 in. rim. Since all rims do not have the same offset from the hub, replacement rims must be of the same offset to ensure consistent alignment of the tire with the water path. The data from the two tires are not interchangeable. **(1)**⁵ Alternative testing for special purposes may be performed with other tires, such as a radial standard reference test tire of Specification E 1136.

4.5 Instrumentation:

4.5.1 General Requirements for Measuring System—The instrumentation system shall conform to the following overall requirements at ambient temperatures between 40 and 100°F (4 and 40°C):

Overall system accuracy— $\pm 1\frac{1}{2}$ % of applied load from 200 lbf (900 N) to full scale; for example, at 200 lbf, applied calibration force of the system output shall be determinable within ± 3 lbf (± 14 N).

Time stability of calibration—10 h, min.

The exposed portions of the system shall tolerate 100 % relative humidity (rain or spray) and all other adverse conditions, such as dust, shock, and vibrations which may be encountered in highway operations.

4.5.2 Force-Measuring Transducer—The tire force-measuring transducer shall be of such design as to measure the tire-road interface force with minimum inertial effects **(2)**. Transducers are recommended to provide an output directly proportional to force with hysteresis less than 1 % of the applied load, nonlinearity less than 1 % of the applied load up to the maximum expected loading, and sensitivity to any expected cross-axis loading or torque loading less than 1 % of the applied load. The force transducer shall be mounted in such a manner as to experience less than 1 deg angular rotation with respect to its measuring plane at the maximum expected loading.

4.5.3 Torque-Measuring Transducer—Torque transducers provide an output directly proportional to torque with hysteresis less than 1 % of the applied load and nonlinearity up to the maximum expected loading less than 1 % of the applied load. It should have sensitivity to any cross-axis loading less than 1 % of the applied load.

4.5.4 Additional Transducers—Force transducers for measuring quantities such as vertical load, etc., shall meet the recommendations stated in 4.5.2.

4.5.5 Vehicle Speed-Measuring Transducers—Transducers such as “fifth wheel” or free-rolling wheel coupled tachometers shall provide speed resolution and accuracy of ± 1.5 % of the indicated speed or ± 0.5 mph (± 0.8 km/h), whichever is greater. Output shall be directly viewable by the driver and shall be simultaneously recorded. Fifth wheel systems shall conform to Method F 457.

4.6 Signal Conditioning and Recorder System:

4.6.1 Transducers that measure parameters sensitive to inertial loading shall be designed or located in such a manner as

to minimize this effect **(3)**. If the foregoing is not practical, data correction must be made for these effects if they exceed 2 % of actual data during expected operation. All signal conditioning and recording equipment shall provide linear output and shall allow data reading resolution to meet the requirements of 4.5.1. All systems, except the smoothing filter recommended in 4.6.2, shall provide a minimum bandwidth of at least 0 to 20 Hz (flat within ± 1 %).

4.6.2 It is recommended that an electronic filter, typically between 4.8 Hz/-3db/4 pole Bessel-type and a 10 Hz/-3db/8 pole Butterworth filter, selected from the types described in Ref **(4)** be installed in the signal conditioning circuit preceding the electronic divider and integration calculation of SN as described in 9.4.

4.6.3 All strain-gage transducers shall be equipped with resistance shunt calibration resistors or equivalent that can be connected before or after test sequences. The calibration signal shall be at least 50 % of the normal vertical load and shall be recorded.

4.6.4 Tire friction force or torque and any additional desired inputs, such as vertical load, wheel speed, etc., shall be recorded in phase ($\pm 5^\circ$ over a bandwidth of 0 to 20 Hz). Vehicle speed shall also be recorded. All signals shall be referenced to a common time base.

4.6.5 A signal to electrical noise ratio of at least 20 to 1 is desirable on all recorded channels.

4.7 Pavement Wetting System:

4.7.1 The water being applied to the pavement ahead of the test tire shall be supplied by a nozzle conforming to the dimensions in Fig. 1. The quantity of water applied at 40 mph (65 km/h) shall be 4.0 gal ± 10 %/min-in. (600 mL/min-mm ± 10 %) of wetted width. The water layer shall be at least 1 in. (25 mm) wider than the test tire tread and applied so the tire is centrally located between the edges. The volume of water per inch (or millimetre) of wetted width shall be directly proportional to the test speed **(5)**.

4.7.2 The nozzle configuration and position shall ensure that the water jets shall be directed toward the test tire and pointed toward the pavement at an angle of 20 to 30°. The water shall strike the pavement 10 to 18 in. (250 to 450 mm) ahead of the vertical axes through the centerline of the test wheel. The nozzle shall be 1 in. (25 mm) above the pavement or the minimum height required to clear obstacles that the tester is expected to encounter, but in no case more than 4 in. (100 mm) above the pavement.

4.7.3 Water used for testing shall be reasonably clean and have no chemicals such as wetting agents or detergents added.

5. Safety Precautions

5.1 The test vehicle, as well as all attachments to it, shall comply with all applicable state and federal laws. All necessary precautions shall be taken beyond those imposed by laws and regulations to ensure maximum safety of operating personnel and other traffic. No test shall be made when there is danger that the dispersed water may freeze on the pavement.

6. Calibration

6.1 Speed—Calibrate the test vehicle speed indicator at the test speed by determining the time for traversing at constant

⁵ The boldface numbers in parentheses refer to the list of references at the end of this method.

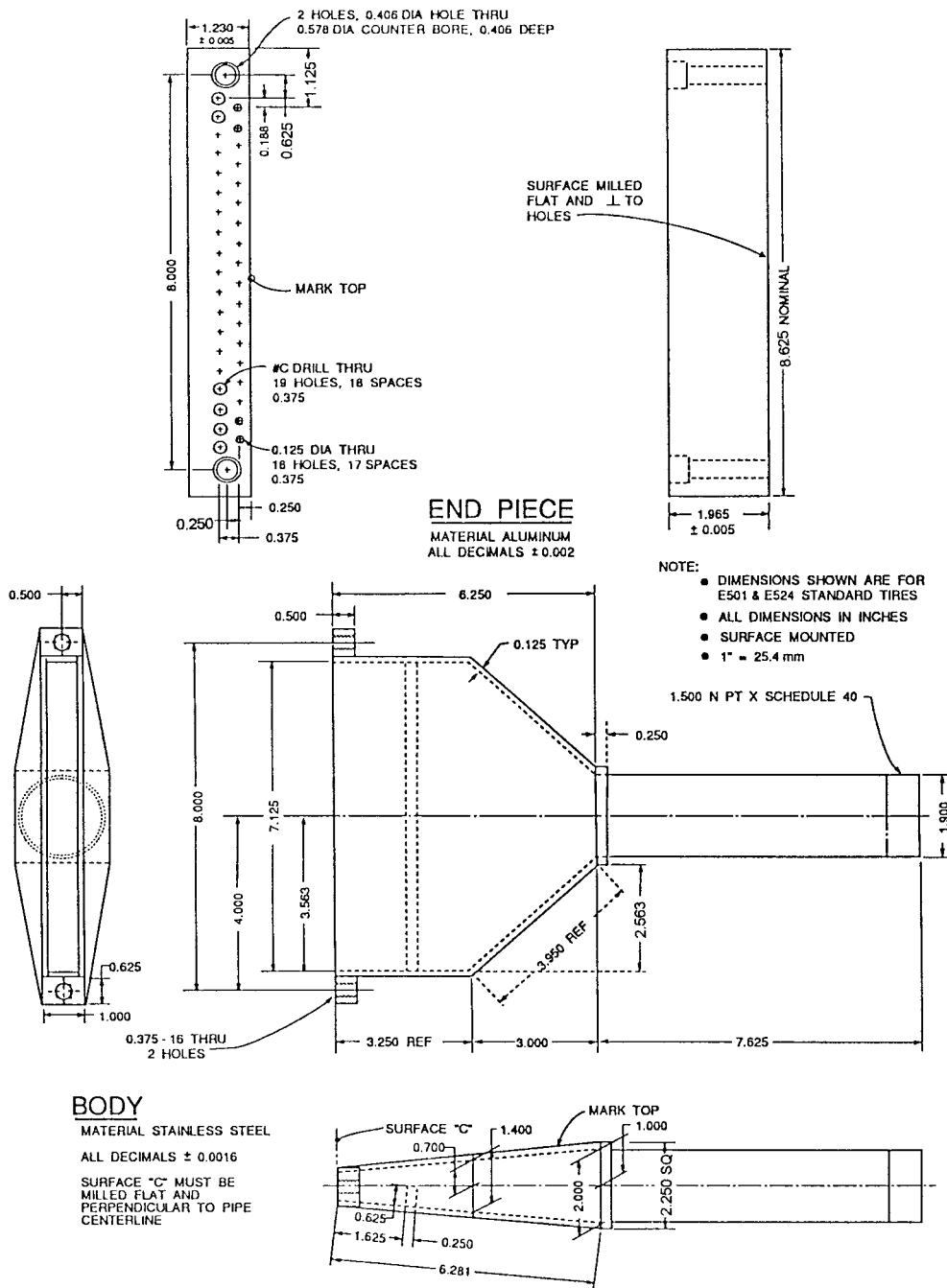

speed a reasonably level and straight, accurately measured pavement of a length appropriate for the method of timing. Load the test vehicle to its normal operating weight for this calibration. Record speed variations during a traverse with the skid-test system. Make a minimum of three runs at each test speed to complete the calibration. Other methods of equivalent accuracy may be used. Calibration of a fifth wheel shall be performed in accordance with Method F 457.

6.2 *Skid Resistance Force*—Place the test wheel of the assembled unit, with its own instrumentation, on a suitable calibration platform, which has been calibrated in accordance with Method F 377, and load vertically to the test load. Measure the test wheel load within ±0.5 % accuracy whenever

the transducer is calibrated. Level the transducers both longitudinally and laterally, such that the tractive force sensitive axis is horizontal. This can be accomplished by minimizing the tractive force output for large variations in vertical load. The system (vehicle or trailer) should be approximately level during this procedure. The calibration platform shall utilize minimum friction bearings and have an accuracy of ±0.5 % of the applied load and a hysteresis of ±0.25 % of the applied load up to the maximum expected loading. Take care to ensure that the applied load and the transducer sensitive axis are in the same vertical line. Perform the tractive force calibration incrementally to not less than 800 lbf (3600 N).

7. General

7.1 *Test Preparation*—Condition new tires by running them at or near their rated load and inflation pressure on the test vehicle (or on another suitable vehicle) at normal traffic speeds for at least 200 miles (300 km) or equivalent before they are used for test purposes. Prior to each series of tests, warm up the tire by traveling for at least 5 miles (10 km) at normal traffic speeds. Inspect the tire for flat spots, damage, or other irregularities that may affect test results, and replace if it has been damaged or is worn beyond the wear line. Check the test-wheel load (if adjustable) and adjust, if necessary, prior to each test series to within the value specified in 4.3. Set the test tire inflation pressure at 24 ± 0.5 psi (165 ± 3 kPa) at ambient temperature just before the 5-mile (10-km) warmup.

7.2 *Test Sections*—Test sections shall be defined as sections of pavement of uniform age and uniform composition that have been subjected to essentially uniform wear. For instance, sharp curves and steep grades shall not be included in the same test section with level tangent sections, nor shall passing lanes be included with traffic lanes. Take skid-resistance measurements only on pavements that are free of obvious contamination.

7.3 *Skid Resistance of a Test Section*—Make at least five determinations of the skid resistance, at intervals not greater than 0.5 mile (1 km), in each test section with the test vehicle at the same lateral position in any one lane and at each specified test speed. Consider the arithmetic average of all determinations to be the skid resistance of the test section. If statistical or other criteria applied to the skid number for a long test section indicate that it cannot be considered to be uniform, treat the section as two or more sections. For treatment of the results of faulty tests, see Section 10.

7.4 *Lateral Positioning of Test Vehicle on Highway*—Normally, testing shall be done in the center of the left wheel track of a traffic lane of a highway. A skid number for a highway surface may be quoted without qualification, only if the test vehicle was so positioned during the test.

7.5 *Test Speeds*—The standard test speed shall be 40 mph (65 km/h), and tests shall normally be conducted at that speed. Where the legal maximum speed is less than 40 mph, the tests may have to be conducted at a lower speed. Where the legal speed is considerably in excess of 40 mph, tests may be made at the prevailing traffic speed, but it is recommended that at the same locations, additional tests be made at 40 mph. Maintain test speeds within ± 1 mph (1.5 km/h).

7.5.1 The test speed and the type tire are to be cited when quoting the obtained skid number. This is to be done by adding the test speed in miles per hour and the letter R for rib tire or S for smooth tire after SN. For example, SN40R indicates that the test was run at a test speed of 40 mph with a Specification E 501 Standard Rib Tire for Pavement Skid Resistance Test, and SN50S indicates that the test was run at a test speed of 50 mph with a Specification E 524 Standard Smooth Tire for Pavement Skid Resistance Test. When the SI system is used, the test speed shall be in parentheses. For example, SN(65)R indicates that the test was run at a test speed of 65 km/h with an E501 Standard Rib for Pavement Skid Resistance Test.

7.6 *Skid-Resistance Speed Gradient Determination*—Report the change of the skid number with speed as the slope

of the SN versus speed curve which is plotted from at least three speeds in increments of approximately 10 mph (15 km/h). The standard speed gradient shall be defined as the slope of the SN-speed curve at 40 mph (65 km/h) and shall be so indicated.

8. Procedure

8.1 Bring the apparatus to the desired speed and deliver water to the pavement ahead of the test tire. Approximately 0.5 s after beginning of the water delivery, apply the test wheel brake so as to lock the wheel completely. The wheel shall remain locked for the duration of the data averaging interval (8.4.1).

8.2 Water delivery may be terminated as soon as the brake is released.

8.3 Record electrical calibration signals prior to and after testing each section, or as needed to ensure valid data.

8.4 *Data Evaluation*—Evaluate the resulting skid-resistance records as follows:

8.4.1 Mark the point of wheel lock-up and measure the data from a point not less than 0.2 s after this mark for an interval not less than 1.0 s nor more than 3.0 s. Average the data between these points and use the mean value to read or to calculate the skid number.

9. Calculation

9.1 Calculate the skid number as follows:

$$SN = (F/W) \times 100 \quad (1)$$

where:

F = tractive force (horizontal force applied to the test tire at the tire-pavement contact patch), lbf (or N), and
 W = dynamic vertical load on test wheel, lbf (or N).

9.2 For trailers not of the parallelogram design (3) or where the vertical wheel load is not measured directly, the wheel load, W , depends on the kinematic layout of the trailer and on the friction force. Wheel load reduction due to unloading produced by the friction force must be taken into account and the following formula used:

$$SN = (F/W) \times 100 \quad (2)$$

where:

W = $W_0 - (H/L) F$,
 H = hitch height, in. (or mm),
 L = trailer wheelbase length (center of axle to center of hitch), in. (or mm), and
 W_0 = static vertical load on the test tire, lbf (or N).

9.3 For a vehicle not of a trailer design, the dynamic vertical load must be either measured or computed by analysis of the statics and kinematics of the test vehicle.

9.4 For instrumentation systems that incorporate automatic dynamic skid number computation equipment, the horizontal tractive force is automatically divided by the dynamic vertical load in real time (see 9.1). The resultant skid number $sn(t)$ is recorded in real time on the strip chart and is available for automatic averaging over the designated averaging period for SN (shown in 8.4.1). The following equations apply:

$$sn(t) = \frac{f_h(t)}{f_v(t)} \times 100 \quad (3)$$

$$SN = \frac{1}{t_2 - t_1} \int_{t_1}^{t_2} sn(t) dt \quad (4)$$

where:

- sn (t) = dynamic skid number in real time,
- $f_h(t)$ = dynamic tractive force in real time, lbf (or N),
- $f_v(t)$ = dynamic vertical load in real time, lbf (or N),
- t_1 = time of start of averaging period, s,
- t_2 = time of end of averaging period, s, and
- SN = mean skid number.

If a 1-s averaging interval is used, then $t_1 = 0$, $t_2 = 1$, and the equation reduces to:

$$SN = \int_0^1 sn(t) dt \quad (5)$$

The arithmetic mean skid number can be recorded on the strip chart as an amplitude trace to the same scale as the dynamic skid number trace and be scaled directly from the chart, or it may be digitized and recorded on magnetic tape, on punched tape, or by printer on paper tape. When the standard rib tire of Specification E 501 is used, the designation shall be SN Test Speed R, and when the standard smooth tire of Specification E 524 is used, the designation shall be SN Test Speed S.

10. Faulty Tests

10.1 Test results that are manifestly faulty, or that differ by more than 5 SN from the average of all tests in the same test section, shall be treated in accordance with Practice E 178.

11. Report

11.1 *Field Report*—The field report for each section shall contain data on the following items:

- 11.1.1 Location and identification of test section,
- 11.1.2 Date and time of day,
- 11.1.3 Weather conditions: principally temperature, cloud cover, and wind,
- 11.1.4 Lane and wheel-path tested,
- 11.1.5 Skid number, speed of test, and test tire type, either SN Test Speed R or SN Test Speed S, for each test in mph; use parentheses for speed in SI units.

11.2 *Summary Report*—The summary report shall include,

for each test section, data on the following items insofar as they are pertinent to the variables or combinations of variables under investigation:

- 11.2.1 Location and identification of test section,
- 11.2.2 Number of lanes and presence of lane separators,
- 11.2.3 Grade and alignment,
- 11.2.4 Pavement type, mix design of surface course, condition, and aggregate type (specific source, if available),
- 11.2.5 Age of pavement,
- 11.2.6 Average daily traffic,
- 11.2.7 Posted speed limit,
- 11.2.8 Date and time of day,
- 11.2.9 Weather conditions,
- 11.2.10 Lane and wheel-path tested,
- 11.2.11 Average, high, and low skid number for the test section and speed at which the tests were made. (If values are reported that were not used in computing the average, this fact shall be recorded.), and
- 11.2.12 Plot of speed gradient data (if obtained).

12. Precision and Bias

12.1 The relationship of observed SN units to some “true” value of locked-wheel sliding friction has not been established at this time. As a result, only repeatability is given for this test method.

12.2 The acceptable precision of SN units can be stated in the form of repeatability. As there is no significant correlation between standard deviation and arithmetic mean of sets of test values, it appears that standard deviations are applicable to this test method regardless of the average locked wheel sliding friction of the surface. An acceptable standard deviation of 2 SN units was obtained from numerous tests conducted on a variety of systems at the Field Test and Evaluation Centers.⁶

12.3 This value is based on evaluations of many skid trailers. The standard deviation of each was determined at each of three speeds on the basis of 36 individual skids, 12 each on each of three pads. It was also determined for each trailer on an over-all speed basis of 108 individual skids, 12 at each of three speeds on each of three pads.

⁶ Supporting data are available from ASTM Headquarters. Request RR:E17-1000.

REFERENCES

- (1) Henry, John Jewett, “Use of Blank and Ribbed Test Tires for Evaluating Wet-Pavement Friction,” *Transportation Research Record* 788.
- (2) Goodenow, G. L., Kolhoff, T. R., and Smithson, F. D., “Tire-Road Friction Measuring System—A Second Generation,” *Society of Automotive Engineers*, Paper No. 680137.
- (3) Kummer, H. W., and Meyer, W. E., “Tentative Skid Resistance Requirements for Main Rural Highways,” *National Cooperative Highway Research Program*, Report No. 37, Highway Research Board, 1967.
- (4) Neill, Jr., A. H., Boyd, P. L., and Hinch, J., “Filtering Techniques for Measuring Peak Braking Coefficients,” *Tire Science and Technology*, Vol 6, No. 4, pp. 263–275, Nov. 1978.
- (5) Goodenow, G. L., “The Design and Construction of the General Motors Proving Ground Model II Coefficient of Friction Vehicle,” Presentation to ASTM Committee E-17, March 22, 1967. Available as General Motors Proving Ground Report PG-26395.
- (6) Smith, L. L., and Fuller, S. L., “Florida Skid Correlation Study of 1967—Skid Testing with Trailers,” *ASTM STP 456*, Am. Soc. Testing and Mats., 1969.
- (7) Cook, L. M., and Dancy, W. H., Jr., “Development and Fabrication of the Virginia Skid-Resistance Measurement Vehicle-Model 2,” *Virginia Highway Research Council* (Box 3817, University Station, Charlottesville, VA 22903).
- (8) Meyer, W. E., Hegmon, R. R., and Gillespie, T. D., “Locked-Wheel Pavement Skid Tester Correlation and Calibration Techniques,” *NCHRP Report No. 151*, Transportation Research Board, 1974.
- (9) Kearns, R. W., and Ward, J. F., “The Static Force Calibration of a Skid

Resistance Measuring System,” Institute for Basic Standards, National Bureau of Standards, Washington, DC, May 1973.

The American Society for Testing and Materials takes no position respecting the validity of any patent rights asserted in connection with any item mentioned in this standard. Users of this standard are expressly advised that determination of the validity of any such patent rights, and the risk of infringement of such rights, are entirely their own responsibility.

This standard is subject to revision at any time by the responsible technical committee and must be reviewed every five years and if not revised, either reapproved or withdrawn. Your comments are invited either for revision of this standard or for additional standards and should be addressed to ASTM Headquarters. Your comments will receive careful consideration at a meeting of the responsible technical committee, which you may attend. If you feel that your comments have not received a fair hearing you should make your views known to the ASTM Committee on Standards, 100 Barr Harbor Drive, West Conshohocken, PA 19428.