



## Standard Test Methods for Analysis of Sulfuric Acid<sup>1</sup>

This standard is issued under the fixed designation E 223; the number immediately following the designation indicates the year of original adoption or, in the case of revision, the year of last revision. A number in parentheses indicates the year of last reapproval. A superscript epsilon (ε) indicates an editorial change since the last revision or reapproval.

*This standard has been approved for use by agencies of the Department of Defense.*

### 1. Scope

- 1.1 These test methods cover the analysis of sulfuric acid.
- 1.2 The analytical procedures appear in the following order:

	Sections
Total Acidity	8 to 16
Baumé Gravity	17 to 26
Nonvolatile Matter	27 to 33
Iron	34 to 43
Sulfur Dioxide	44 to 51
Arsenic	52 to 61

1.3 *This standard does not purport to address all of the safety concerns, if any, associated with its use. It is the responsibility of the user of this standard to establish appropriate safety and health practices and determine the applicability of regulatory limitations prior to use.* Specific hazards statements are given in Section 5.

### 2. Referenced Documents

- 2.1 *ASTM Standards:*
  - D 1193 Specification for Reagent Water<sup>2</sup>
  - E 1 Specification for ASTM Thermometers<sup>3</sup>
  - E 60 Practice for Photometric and Spectrophotometric Methods for Chemical Analysis of Metals<sup>4</sup>
  - E 180 Practice for Determining the Precision of ASTM Methods for Analysis and Testing of Industrial Chemicals<sup>5</sup>
  - E 200 Practice for Preparation, Standardization, and Storage of Standard and Reagent Solutions for Chemical Analysis<sup>5</sup>

### 3. Significance and Use

3.1 These test methods provide for the classification of various grades of sulfuric acid and for the determination of various impurities. Acid strength and impurity levels are important factors in many uses of sulfuric acid.

### 4. Purity of Reagents

- 4.1 *Purity of Reagents*—Reagent grade chemicals shall be

<sup>1</sup> These test methods are under the jurisdiction of ASTM Committee E-15 on Industrial Chemicals and are the direct responsibility of Subcommittee E15.51 on Acids.

Current edition approved Dec. 10, 1996. Published June 1997. Originally published as E 223 – 65 T. Last previous edition E 223 – 93.

<sup>2</sup> *Annual Book of ASTM Standards*, Vol 11.01.

<sup>3</sup> *Annual Book of ASTM Standards*, Vol 14.03.

<sup>4</sup> *Annual Book of ASTM Standards*, Vol 03.05.

<sup>5</sup> *Annual Book of ASTM Standards*, Vol 15.05.

used in all tests. Unless otherwise indicated, it is intended that all reagents shall conform to the specifications of the Committee on Analytical Reagents of the American Chemical Society, where such specifications are available.<sup>6</sup> Other grades may be used, provided it is first ascertained that the reagent is of sufficiently high purity to permit its use without lessening the accuracy of the determination.

4.2 *Purity of Water*—Unless otherwise indicated, references to water shall be understood to mean Type II or Type III reagent water conforming to Specification D 1193.

### 5. Hazards

5.1 Sulfuric acid is a strong corrosive acid and is dangerous if improperly handled. Avoid any skin or eye contact.

5.2 Clean up all spills immediately by covering the spill with vermiculite or some other inert absorbent material and sweeping into a pan. Dispose of the absorbent by flooding with water and discarding in a suitable container. Flush the area with water.

### 6. Photometers and Photometric Practice

6.1 Photometers and the photometric practice used in these test methods shall conform to Practice E 60.

### 7. Sampling

7.1 Sampling of sulfuric acid is not within the scope of these test methods.

7.2 The sample to be analyzed shall be considered to be that sample in a single bottle submitted to the analytical laboratory.

7.3 The size of the sample shall be sufficient to perform all analyses without the reuse of any portion of the sample.

## TOTAL ACIDITY

### 8. Scope

8.1 This test method covers the determination of the total acidity of 75 to 99 % sulfuric acid. Two test methods are given for weighing the sample, namely, the Dely tube and the snake tube test methods.

<sup>6</sup> *Reagent Chemicals, American Chemical Society Specifications*, American Chemical Society, Washington, DC. For suggestions on the testing of reagents not listed by the American Chemical Society, see *Analar Standards for Laboratory Chemicals*, BDH Ltd., Poole, Dorset, U.K., and the *United States Pharmacopeia and National Formulary*, U.S. Pharmacopeial Convention, Inc. (USPC), Rockville, MD.

**9. Summary of Test Method**

9.1 A weighed sample of acid is diluted in water and titrated with standardized 0.5 N sodium hydroxide solution, using phenolphthalein as the indicator.

**10. Interferences**

10.1 Acids other than sulfuric and compounds that consume sodium hydroxide will affect the accuracy of this test method.

**11. Apparatus**

11.1 *Dely Tube* (Fig. 1) or *Snake Tube* (Fig. 2).<sup>7</sup>

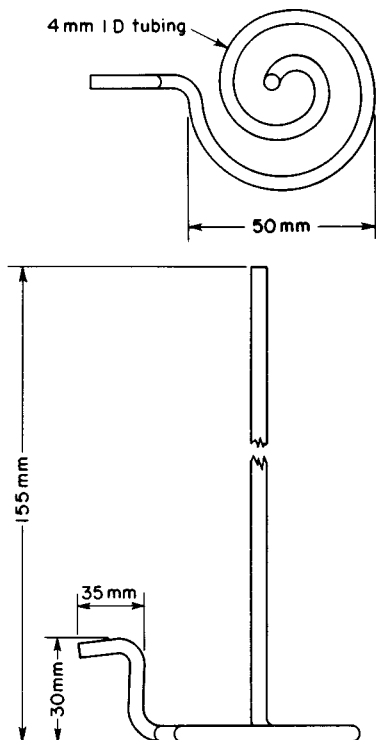

FIG. 1 Dely Tube

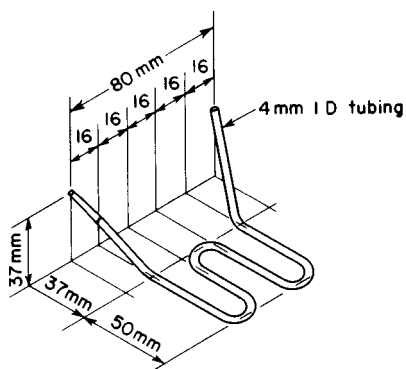

FIG. 2 Snake Tube

11.2 *Buret*, 100-mL, Class A, bulb-type.

**12. Reagents**

12.1 *Phenolphthalein Indicator Solution* (10 g/L)—Dissolve 1 g of phenolphthalein in 100 mL of ethanol (95 %), methanol, or isopropanol.<sup>8</sup>

12.2 *Sodium Hydroxide, Standard Solution* (0.5 N)—See Practice E 200.

**13. Procedure**

13.1 *Dely Tube Test Method*—Invert the sample bottle several times. (Hold the stopper in tight.) Insert the long arm of a dry, weighed Dely tube and withdraw by suction a convenient size sample depending upon the acid strength as given in Table 1 (Note 1). Invert the Dely tube and wipe the acid from the

TABLE 1 Sample Size for Total Acidity

H <sub>2</sub> SO <sub>4</sub> , %	Sample Size, g
98	1.9 to 2.2
94	2.0 to 2.3
90	2.1 to 2.4
85	2.2 to 2.6
80	2.3 to 2.7
77	2.4 to 2.8
75	2.5 to 2.9

long arm with disposable tissue several layers thick. Discard the tissue immediately to avoid burning the fingers. Reweigh to the nearest 0.0001 g and record the weight of the sample. Incline the tube so that the acid runs back nearly to the bend of the short arm. Attach the short arm to an elevated water reservoir by means of a rubber tube closed near the lower end with a pinch clamp. Insert the long arm of the Dely tube into 400-mL glass beaker containing approximately 100 mL of water. Open the pinch clamp and flush the sample into the beaker. Continue the flow of water until all acid is washed from the Dely Tube (Note 2 and Note 3). Wash the long end of the Dely tube, collecting the washings in the beaker. Add 3 to 5 drops of phenolphthalein indicator solution. Record the temperature of the 0.5 N NaOH solution, and then titrate the sample to a pink end point. Record the titration to the nearest 0.02 mL.

NOTE 1—The Dely tube can be marked at points equivalent to weights given in Table 1.

NOTE 2—The presence of acid in the Dely tube may be detected by coloring the water in the reservoir with phenolphthalein indicator and the minimum amount of dilute NaOH solution that will produce a slight pink. The water flowing through the tube is decolorized as long as acid is present, and the appearance of a pink color indicates the absence of acid.

NOTE 3—The acid and water are separated by a bubble of air.

13.2 *Snake Tube Test Method*—Invert the sample bottle several times. (Hold the stopper in tight). Insert the capillary end of a dry, weighed snake tube and withdraw by suction a convenient size sample depending upon the acid strength as given in Table 1. Invert the tube so that the double bend is in a horizontal position. Wipe the acid from the capillary with disposable tissue several layers thick. Discard the tissue immediately to avoid burning the fingers. Reweigh to the

<sup>7</sup> Suitable Dely and snake tubes are available from Corning Glass Works, Corning, NY.

<sup>8</sup> This reagent is also described in Practice E 200.

nearest 0.0001 g and record the weight of the sample. Submerge the capillary of the tube in approximately 100 mL of water contained in the 400-mL beaker. Force the weighed sample from the tube by a stream of water from a wash bottle by placing the delivery tip in the exposed end of the snake tube (Note 4). Wash the tube with 50 to 70 mL of water. Remove the tube and wash the outside free of acid. Swirl the contents of the beaker gently while washing. Accumulate all washings in the beaker and add 3 to 5 drops of phenolphthalein indicator solution. Record the temperature of the 0.5 N NaOH solution, and then titrate the sample to a pink end point. Record the titration to the nearest 0.02 mL.

NOTE 4—Do not introduce the water into the snake tube too rapidly, as this will cause spattering.

#### 14. Calculation

14.1 If necessary, correct the buret reading for calibration errors and record the volume of titrant as  $V$  and the temperature as  $t$ .

14.2 Correct the normality of the sodium hydroxide standard solution for any difference in temperature between time of standardization and time of use according to the following equation:

$$N = N_s + 0.00014 (s - t) \quad (1)$$

where:

$N$  = normality of NaOH solution at temperature  $t$  during use,

$N_s$  = normality of NaOH solution at temperature  $s$  during standardization,

$s$  = temperature of NaOH solution during standardization, and

$t$  = temperature of NaOH solution during analysis.

14.3 Calculate the total acidity as percentage of sulfuric acid as follows:

$$\text{Sulfuric acid, wt \%} = \frac{(VN \times 0.04904)}{W} \times 100 \quad (2)$$

where:

$V$  = corrected millilitre of NaOH solution required for titration of the sample,

$N$  = normality of the NaOH solution, and

$W$  = grams of sample used.

#### 15. Report

15.1 Report the percentage of sulfuric acid to the nearest 0.01 %.

#### 16. Precision and Bias

16.1 The following criteria should be used for judging the acceptability of results (see Note 5):

16.1.1 *Repeatability (Single Analyst)*—The standard deviation for a single determination has been estimated to be 0.069 % absolute at 56 df. The 95 % limit for the difference between two such runs is 0.19 % absolute.

16.1.2 *Laboratory Precision (Within-Laboratory, Between-Days Variability), Formerly Called Repeatability*—The standard deviation of results (each the average of duplicates), obtained by the same analyst on different days, has been

estimated to be 0.104 % absolute at 28 df. The 95 % limit for the difference between two such averages is 0.29 % absolute.

16.1.3 *Reproducibility (Multilaboratory)*—The standard deviation of results (each the average of duplicates), obtained by analysts in different laboratories, has been estimated to be 0.124 % absolute at 7 df. The 95 % limit for the difference between two such averages is 0.35 % absolute.

NOTE 5—These precision estimates are based on an interlaboratory study of analyses performed in 1963 on three samples containing approximately 80, 90, and 95 % sulfuric acid. One analyst in each of ten laboratories performed duplicate determinations and repeated one day later, for a total of 120 determinations.<sup>9</sup> Practice E 180 was used in developing these precision estimates.

16.2 Since there is no accepted reference material for determining the bias for measuring the total acidity of sulfuric acid, the bias of this test method has not been determined.

### BAUMÉ GRAVITY

#### 17. Scope

17.1 This test method covers the determination of the Baumé gravity of concentrated sulfuric acid by means of a glass hydrometer in the range from 57 to 66.2° Baumé. The Baumé gravity is determined at 15.5°C (60°F). This test method is not applicable to readings above 66.2 Baumé gravity units.

#### 18. Definition

18.1 *Baumé Gravity*—a unit of density based on specific gravity and defined by the following equation:

$$\text{Baumé gravity} = 145 - [145/\text{sp gr}] \text{ at } 15.5/15.5^\circ\text{C (60/60}^\circ\text{F)} \quad (3)$$

#### 19. Summary of Test Method

19.1 A sample of sulfuric acid is placed in a hydrometer cylinder and when the temperature is constant, the Baumé gravity is read from the glass hydrometer.

#### 20. Significance and Use

20.1 The Baumé gravity is used to classify various grades of sulfuric acid. This test method is not applicable for accurate determinations of the concentration of sulfuric acid.

#### 21. Apparatus

21.1 *Hydrometer*,<sup>10</sup> streamline or torpedo design, precision grade for liquids heavier than water in ranges from 57 to 62° Bé and 63 to 67° Bé. The total length shall be approximately 12 in. (305 mm) divided to 0.05° Bé over a 6-in. (152-mm) (approximate) scale and standardized at 15.5/15.5°C (60/60°F) with a tolerance of 0.05° Bé throughout. The modulus is as follows

$$\text{Bé} = 145 - [145/\text{sp gr}] \text{ at } 15.5/15.5^\circ\text{C (60/60}^\circ\text{F)} \quad (4)$$

Each of the hydrometers shall show on the scale the modulus.

<sup>9</sup> Details of the interlaboratory study are available from ASTM Headquarters. Request RR: E15-1047.

<sup>10</sup> Suitable hydrometers are available from Walter H. Kessler, Inc., 160 Hicks St., Westbury, L.I., NY 11590.

21.2 *Thermometer*, having a range from  $-2$  to  $+80^{\circ}\text{C}$  ( $30$  to  $180^{\circ}\text{F}$ ) and conforming to the requirements for Thermometer 15C (15F) as prescribed in Specification E 1.

21.3 *Cylinder, Hydrometer*, glass, with or without lip, diameter 38 to 40 mm, height 325 to 375 mm.

## 22. Temperature of Test

22.1 Baumé gravity shall be determined at  $15.5 \pm 0.3^{\circ}\text{C}$  ( $60 \pm 0.5^{\circ}\text{F}$ ).

## 23. Procedure

23.1 Rinse a clean hydrometer cylinder with the sample to be tested, add the sample, and adjust the temperature to  $15.5 \pm 0.3^{\circ}\text{C}$  ( $60 \pm 0.5^{\circ}\text{F}$ ). Place the cylinder in a vertical position in a location free of air currents. Insert the hydrometer in the sample. Push it down about 3 mm below the level at which it will float and release it. Read the hydrometer when it has come to rest, floating freely, and the temperature is  $15.5^{\circ}\text{C}$  ( $60^{\circ}\text{F}$ ). The correct reading is that point on the hydrometer scale at which the surface of the liquid cuts the scale. Determine this point by placing the eye slightly below the level of the liquid and slowly raising it until the surface, first seen as a distorted ellipse, appears to become a straight line cutting the hydrometer scale. Record as Baumé gravity.

## 24. Calculation

24.1 Calculate the specific gravity for later calculations in accordance with the following equation:

$$\text{sp gr} = \frac{145}{145 - B\bar{e}} \quad (5)$$

## 25. Report

25.1 Report the Baumé gravity to the nearest 0.01 unit.

## 26. Precision and Bias

26.1 The following criteria should be used for judging the acceptability of results (see Note 6):

26.1.1 *Repeatability (Single Analyst)*—The standard deviation for a single determination has been estimated to be 0.018 unit absolute at 48 df. The 95 % limit for the difference between two such runs is 0.05 unit absolute.

26.1.2 *Laboratory Precision (Within-Laboratory, Between-Days Variability), Formerly Called Repeatability*—The standard deviation of results (each the average of duplicates), obtained by the same analyst on different days, has been estimated to be 0.016 unit absolute at 24 df. The 95 % limit for the difference between two such averages is 0.045 unit absolute.

26.1.3 *Reproducibility (Multilaboratory)*—The standard deviation of results (each the average of duplicates), obtained by analysts in different laboratories, has been estimated to be 0.063 unit absolute at 7 df. The 95 % limit for the difference between two such averages is 0.18 unit absolute.

NOTE 6—These precision estimates are based on an interlaboratory study of analyses performed in 1963 on three samples having Baumé gravities of approximately 61, 65, and 66 units. One analyst in each of nine laboratories performed duplicate determinations and repeated one day later, for a total of 104 determinations.<sup>9</sup> Practice E 180 was used in developing these precision estimates.

26.2 Since there is no accepted reference material for determining the bias for measuring the Baumé gravity of sulfuric acid, the bias of this test method has not been determined.

## NONVOLATILE MATTER

### 27. Scope

27.1 This test method covers the gravimetric determination of nonvolatile matter in sulfuric acid. The lower limit of determination of nonvolatile matter is 0.001 %.

### 28. Summary of Test Method

28.1 A weighed sample of acid is evaporated, ignited, and the residue weighed.

### 29. Apparatus

29.1 *Evaporating Dish*, platinum or high-silica glass, 150-mL.

29.2 *Muffle Furnace*, maintained at  $800 \pm 25^{\circ}\text{C}$  ( $1472 \pm 45^{\circ}\text{F}$ ).

29.3 *Crucible Tongs*.

### 30. Procedure

30.1 Clean a platinum or a high-silica glass dish (Note 7 and Note 8) and ignite in a muffle furnace at  $800 \pm 25^{\circ}\text{C}$  ( $1472 \pm 45^{\circ}\text{F}$ ) for at least 10 min. Cool in a desiccator to room temperature and weigh the dish to the nearest 0.1 mg (Note 9).

NOTE 7—New platinum or high-silica glass dishes should be boiled in HCl (1 + 1) for 10 min, washed, and ignited in the muffle furnace for at least 1 h before their first use.

NOTE 8—High-silica glass dishes should be used only for low nonvolatile material. The residue remaining from samples containing large amounts of nonvolatile matter may fuse into the dish.

NOTE 9—High-silica glass dishes should be allowed to cool at least 45 min and platinum dishes at least 20 min before weighing.

30.2 Mix the sample by inverting the sample bottle repeatedly until all solids are in suspension.

NOTE 10—It is important that the sample be well mixed and that all solids are in homogeneous suspension so that a representative sample can be obtained.

30.3 Transfer a weighed sample containing a minimum of 50 g, weighed to the nearest 0.1 g, or a weighed sample of sufficient size to yield not less than 1 mg of residue, to the evaporating dish and evaporate to dryness over a burner or hot plate in a hood. After evaporation, ignite the sample in the muffle furnace for 10 min. Use crucible tongs in handling the evaporating dish at all times.

30.4 Allow the dish to cool to room temperature in a desiccator and rapidly weigh the sample dish to the nearest 0.1 mg.

### 31. Calculation

31.1 Calculate the percentage of nonvolatile matter as follows (Note 11):

$$\text{Nonvolatile matter, wt \%} = \frac{(R - D)}{W} \times 100 \quad (6)$$

where:

$R$  = weight of evaporating dish and residue, g,

$D$  = weight of evaporating dish, g, and

$W$  = sample used, g.

NOTE 11—If this value is less than 0.0010 %, report as less than 0.0010 %.

### 32. Report

32.1 Report the percentage of nonvolatile matter to the nearest 0.0001 %.

### 33. Precision and Bias

33.1 The following criteria should be used for judging the acceptability of results (see Note 12):

33.1.1 *Repeatability (Single Analyst)*—The standard deviation for a single determination has been estimated to be the value in Table 2 at the indicated degrees of freedom. The

TABLE 2 Nonvolatile Matter Precision Values

NVM, %	Repeatability			Laboratory Precision			Reproducibility		
	Standard Deviation	Degrees of Freedom	95 % Range	Standard Deviation	Degrees of Freedom	95 % Range	Standard Deviation	Degrees of Freedom	95 % Range
0.003	0.0004	22	0.0010	0.0004	11	0.0010	0.0015	10	0.0040
0.004	0.0008	16	0.0007	0.0007	8	0.0019	0.0013	7	0.0036
0.01 to 0.024	0.0015	54	0.0042	0.0009	27	0.0024	0.0013	7	0.0036
0.048	0.0009	20	0.0025	0.0013	10	0.0036	0.0046	9	0.0130

95 % limit for the difference between two such runs is given in Table 2.

33.1.2 *Laboratory Precision (Within-Laboratory, Between-Days Variability), Formerly Called Repeatability*—The standard deviation of results (each the average of duplicates), obtained by the same analyst on different days, has been estimated to be the value in Table 2 at the indicated degrees of freedom. The 95 % limit for the difference between two such averages is given in Table 2.

33.1.3 *Reproducibility (Multilaboratory)*—The standard deviation of results (each the average of duplicates), obtained by analysts in different laboratories, has been estimated to be the value given in Table 2 at the indicated degrees of freedom. The 95 % limit for the difference between two such averages is given in Table 2.

NOTE 12—These precision estimates are based on an interlaboratory study of analyses performed in 1963–1964 on five samples containing approximately 0.003, 0.005, 0.010, 0.014, 0.024, and 0.048 % nonvolatile matter. One analyst in each of eight to ten laboratories performed duplicate determinations and repeated one day later.<sup>9</sup> Practice E 180 was used in developing these precision estimates.

33.2 Since there is no accepted reference material for determining the bias for measuring the nonvolatile matter of sulfuric acid, the bias of this test method has not been determined.

## IRON

### 34. Scope

34.1 This test method describes the determination of iron in sulfuric acid. The lower limit of determination of iron is 0.0001 %.

### 35. Summary of Test Method

35.1 The iron is reduced and determined colorimetrically with 1,10-phenanthroline (*ortho*-phenanthroline), which forms an orange-red complex with ferrous iron. The intensity of the color so formed is measured in a photometer calibrated with standard iron solutions.

### 36. Interferences

36.1 It is beyond the scope of this test method to describe procedures for overcoming all possible interferences that may be encountered. Chromium interferes if it is present in sufficient quantity for the color of chromic ion to have a masking effect. Copper, antimony, cobalt, mercury (I), and tin (II, IV) interfere in concentrations of 10 to 50 ppm. Cadmium, mercury (II), zinc, and nickel may interfere, but can be overcome by the use of excess 1,10-phenanthroline reagent.

### 37. Apparatus

37.1 *Photometer*—Any photoelectric spectrophotometer or filter photometer that will measure the absorbance of the solutions in the wavelength range from 500 to 525 nm.

37.2 *Absorption Cells, 2-cm light path.*

NOTE 13—This procedure has been written for a cell having a 2-cm light path. Cells having other dimensions may be used, provided suitable adjustments can be made in the amounts of sample and reagents used.

### 38. Reagents

38.1 *Ammonium Acetate–Acetic Acid Solution*—Dissolve 100 g of ammonium acetate ( $\text{CH}_3\text{COONH}_4$ ) in about 600 mL of water, filter, add 200 mL of glacial acetic acid to the filtrate, and dilute to 1 L.

38.2 *Ammonium Hydroxide Solution (1 + 1)*—Dilute to 500 mL of ammonium hydroxide ( $\text{NH}_4\text{OH}$ ) with 500 mL of water, and mix.<sup>8</sup>

38.3 *Congo Red Paper.*

38.4 *Hydroxylamine Hydrochloride Solution (100 g/L)*—Dissolve 100 g of hydroxylamine hydrochloride ( $\text{NH}_2\text{OH}\cdot\text{HCl}$ ) in about 600 mL of water, filter, and dilute to 1 L.<sup>8</sup>

38.5 *Iron, Standard Solution (1 mL = 0.01 mg Fe)<sup>11</sup>*—See Practice E 200.

38.6 *1,10-Phenanthroline (o-Phenanthroline) Solution (3 g/L)*—Dissolve 3 g of *ortho*-phenanthroline monohydrate in 500 mL of water, add 1 mL of hydrochloric acid (HCl), mix, filter, and dilute to 1 L.<sup>8</sup>

### 39. Calibration

39.1 To a series of 100-mL volumetric flasks, pipet 0, 2, 4,

<sup>11</sup> This reagent is used for calibrating purposes only.

8, and 10 mL of standard iron solution. To each flask add the following reagents in order, mixing after addition of each: 20 mL of water, 1 mL of hydroxylamine hydrochloride solution, 5 mL of 1,10-phenanthroline solution, and  $\text{NH}_4\text{OH}$  (1 + 1) as required to bring the pH to 3.5 to 4.0 (just alkaline to Congo red paper). Add 5 mL of ammonium acetate solution, dilute to the mark with water, mix thoroughly, and allow to stand approximately 15 min.

39.2 Measure the absorbances of the solutions using a photometer with a wavelength setting of 510 nm or a filter photometer equipped with a filter in the range from 500 to 525 nm, adjusting the photometer to read zero absorbance for the reagent blank.

39.3 Plot on coordinate paper the absorbances of the calibration solutions against milligrams of iron present per 100 mL of solution.

#### 40. Procedure

40.1 Mix the sample by inverting the sample bottle until all solids are in suspension (Note 10).

40.2 Insert a 70-mm stem funnel in a 100-mL volumetric flask and add 50 mL of water (Note 14). Remove the funnel and slowly add, with continual swirling of the contents of the flask, 1 g of sample weighed by difference to the nearest 0.001 g. Wash down the neck of the flask with approximately 5 mL of water.

NOTE 14—This is done to keep the neck of the flask dry and prevent spitting or spattering on introducing the sample.

40.3 Add to the flask the following reagents in order, mixing after the addition of each: 1 mL of hydroxylamine hydrochloride solution, 5 mL of 1,10-phenanthroline solution, and  $\text{NH}_4\text{OH}$  (1 + 1) as required to bring the pH of the solution to 3.5 to 4.0 (just alkaline to Congo red paper). Add 5 mL of ammonium acetate solution, dilute to the mark with water, mix thoroughly, and allow to stand approximately 15 min.

40.4 Prepare a blank solution using all reagents but omitting the sample. Allow to stand about 15 min.

40.5 Determine the absorbance of the sample at the same wavelength used for the calibration curve, blanking the instrument at zero absorbance with the blank solution. Determine from the calibration curve the milligrams of iron that correspond to the observed absorbance of the sample.

NOTE 15—If the color obtained is too intense to fall within the range of the calibration curve, repeat with a smaller sample.

NOTE 16—If the color obtained is less than that obtained with 0.01 mg of iron, repeat as follows: Transfer 10 g of sample, weighed by difference to the nearest 0.01 g, to a 50-mL beaker and evaporate almost to dryness over a burner or hotplate in a hood. Cool. Add 10 mL of water and 2 mL of HCl (sp gr 1.19) and heat to dissolve any solids. Transfer the solution to a 100-mL volumetric flask with a minimum amount of water and proceed in accordance with 40.3 starting with the addition of 1 mL of hydroxylamine hydrochloride solution.

#### 41. Calculation

41.1 Calculate the percentage of iron as follows (Note 17):

$$\text{Iron, wt \%} = \frac{M}{W \times 1000} \times 100 \quad (7)$$

where:

$M$  = iron, found from calibration curve, mg, and

$W$  = sample used, g.

NOTE 17—If this value is less than 0.0001 %, report as less than 0.0001 %.

#### 42. Report

42.1 Report the percentage of iron to the nearest 0.0001 %.

#### 43. Precision and Bias

43.1 The following criteria should be used for judging the acceptability of results (see Note 18):

43.1.1 *Repeatability (Single Analyst)*—The standard deviation for a single determination has been estimated to be 0.00018 % absolute at 52 df. The 95 % limit for the difference between two such runs is 0.0005 % absolute.

43.1.2 *Laboratory Precision (Within-Laboratory, Between-Days Variability), Formerly Called Repeatability*—The standard deviation of results (each the average of duplicates), obtained by the same analyst on different days, has been estimated to be 0.00021 % absolute at 26 df. The 95 % limit for the difference between two such averages is 0.0006 % absolute.

43.1.3 *Reproducibility (Multilaboratory)*—The standard deviation of results (each the average of duplicates), obtained by analysts in different laboratories, has been estimated to be 0.00034 % absolute at 6 df. The 95 % limit for the difference between two such averages is 0.0009 % absolute.

NOTE 18—These precision estimates are based on an interlaboratory study of analyses performed in 1963–1964 on three samples containing approximately 0.004, 0.005, and 0.008 % iron. One analyst in each of nine laboratories performed duplicate determinations and repeated one day later, for a total of 108 determinations.<sup>9</sup> Practice E 180 was used in developing these precision estimates.

One sample, containing approximately 0.0003 % iron and analyzed by one analyst in each of eight laboratories for a total of 32 determinations, gave the following precision data:

*Repeatability (Single Analyst)*—The standard deviation for a single determination has been estimated to be 0.000041 % absolute at 16 df. The 95 % limit for the difference between two such runs is 0.0001 % absolute.

*Laboratory Precision (Within-Laboratory, Between-Days Variability), Formerly Called Repeatability*—The standard deviation of results (each the average of duplicates), obtained by the same analyst on different days, has been estimated to be 0.000051 % absolute at 8 df. The 95 % limit for the difference between two such averages is 0.0001 % absolute.

*Reproducibility (Multilaboratory)*—The standard deviation of results (each the average of duplicates), obtained by analysts in different laboratories, has been estimated to be 0.00014 % absolute at 7 df. The 95 % limit for the difference between two such averages is 0.0004 % absolute.

43.1.4 Above 0.01 % iron, the precision is poor because of difficulty in sampling.

43.2 Since there is no accepted reference material for determining the bias for measuring the iron content of sulfuric acid, the bias of this test method has not been determined.

### SULFUR DIOXIDE

#### 44. Scope

44.1 This test method covers the determination of free sulfur dioxide dissolved in sulfuric acid. The lower limit of

determination of sulfur dioxide is 0.002 %.

#### 45. Summary of Test Method

45.1 The sulfur dioxide is swept out of the sample of sulfuric acid by means of a current of nitrogen gas. The evolved sulfur dioxide is absorbed in an alkaline solution, treated with an excess of iodate-iodide solution and the excess is titrated with sodium thiosulfate.

#### 46. Apparatus

46.1 *Evolution and Absorption Train*, consisting of:

46.1.1 *Source of Pure Nitrogen Gas*, connected to

46.1.2 *Drechsel Gas-Washing Bottle*, 125-mL, connected as a safety trap to prevent acid suck-back, connected to

46.1.3 *Drechsel Gas-Washing Bottle*, 125-mL, with fritted glass disk on the inlet tube, connected to

46.1.4 *Drechsel Gas-Washing Bottle*, 250-mL, with fritted glass disk on the inlet tube.

#### 47. Reagents

47.1 *Potassium Iodate-Potassium Iodide Solution* (approximately 0.1 *N*)—Dissolve 4 g of potassium iodate (KIO<sub>3</sub>) and 100 g of potassium iodide (KI) in water and dilute to 1 L with water.

47.2 *Sodium Hydroxide Solution* (4 g/L)—Dissolve 4 g of sodium hydroxide (NaOH) in water and dilute to 1 L.<sup>8</sup>

47.3 *Sodium Thiosulfate, Standard Solution* (0.1 *N*)—See Practice E 200.

47.4 *Sodium Thiosulfate, Standard Solution* (0.01 *N*)—Pipet 100 mL of 0.1 *N* sodium thiosulfate (Na<sub>2</sub>S<sub>2</sub>O<sub>3</sub>) solution into a 1-L volumetric flask, dilute to volume with water, and mix. The normality is exactly one tenth that of the 0.1 *N* solution.

47.5 *Starch Indicator Solution* (10 g/L)—Mix 1 g of soluble starch with 5 mg of red mercuric iodide (HgI<sub>2</sub>) and enough cold water to make a thin paste, and pour slowly, with constant stirring, into 100 mL of boiling water. Boil the mixture while stirring until a thin, translucent fluid is obtained. Cool before use.<sup>8</sup>

47.6 *Sulfuric Acid* (1 + 5)—Mix carefully while stirring, 1 volume of concentrated sulfuric acid (H<sub>2</sub>SO<sub>4</sub>, sp gr 1.84) with 5 volumes of water.

#### 48. Procedure

48.1 Flush out the safety bottle with nitrogen.

48.2 From a graduated cylinder, transfer about 50 mL of the sample into the 125-mL Drechsel bottle and connect to the safety bottle. Note the millilitres of sample used, *W*.

48.3 Place about 100 mL of the NaOH solution in 250-mL Drechsel bottle and connect to the 125-mL Drechsel bottle.

48.4 Pass nitrogen gas through the apparatus at about 20 L/h for 3 h.

48.5 Disconnect the bottle containing the NaOH solution and turn off the nitrogen flow. Rinse the bubbler tube with water into the bottle, pipet 5 mL of the KIO<sub>3</sub>-KI solution into the bottle, and mix.

48.6 Add 5 mL of H<sub>2</sub>SO<sub>4</sub> (1 + 5) and 2 mL of the starch indicator solution and titrate with the 0.01 *N* Na<sub>2</sub>S<sub>2</sub>O<sub>3</sub> solution until the blue color is discharged. Record the volume of

Na<sub>2</sub>S<sub>2</sub>O<sub>3</sub> solution used, *A*. (If no blue color is evident, repeat the procedure with 25 mL of sample.)

48.7 Repeat the entire procedure, substituting 50 mL of water for the sample in the 125-mL Drechsel bottle. Record the volume of Na<sub>2</sub>S<sub>2</sub>O<sub>3</sub> solution used, *B*.

48.8 If the back titration of the sample solution requires more than 30 mL of the Na<sub>2</sub>S<sub>2</sub>O<sub>3</sub> solution repeat both the blank and sample determinations, using only 2 mL of the KIO<sub>3</sub>-KI solution.

#### 49. Calculation

49.1 Calculate the percentage of sulfur dioxide as follows (Note 19):

$$\text{Sulfur dioxide, wt \%} = \frac{(B - A) \times N \times 0.032}{W \times \text{sp gr}} \times 100 \quad (8)$$

where:

*B* = Na<sub>2</sub>S<sub>2</sub>O<sub>3</sub> solution required for the titration of the blank solution, mL,

*A* = Na<sub>2</sub>S<sub>2</sub>O<sub>3</sub> solution required for the titration of the sample solution, mL,

*N* = normality of the Na<sub>2</sub>S<sub>2</sub>O<sub>3</sub> solution, and

*W* = sample used, mL.

NOTE 19—If this value is less than 0.002 %, report as less than 0.002 %.

#### 50. Report

50.1 Report the percentage of sulfur dioxide to the nearest 0.001 %.

#### 51. Precision and Bias

51.1 The following criteria should be used for judging the acceptability of results (see Note 20):

51.1.1 *Repeatability (Single Analyst)*—The coefficient of variation for a single determination has been estimated to be 10.1 % relative at 42 df. The 95 % limit for the difference between two such runs is 28 % relative.

51.1.2 *Laboratory Precision (Within-Laboratory, Between-Days Variability), Formerly Called Repeatability*—The coefficient of variation of results (each the average of duplicates), obtained by the same analyst on different days, has been estimated to be 7.45 % relative at 21 df. The 95 % limit for the difference between two such averages is 21 % relative.

51.1.3 *Reproducibility (Multilaboratory)*—The coefficient of variation of results (each the average of duplicates), obtained by analysts in different laboratories, has been estimated to be 15.7 % relative at 6 df. The 95 % limit for the difference between two such averages is 44 % relative.

NOTE 20—These precision estimates are based on an interlaboratory study of analyses performed in 1967 on three samples containing approximately 0.004, 0.008, and 0.016 % sulfur dioxide. One analyst in each of seven laboratories performed duplicate determinations and repeated one day later, for a total of 84 determinations.<sup>9</sup> Practice E 180 was used in developing these precision estimates.

51.2 Since there is no accepted reference material for determining the bias for measuring the sulfur dioxide content of sulfuric acid, the bias of this test method has not been determined.

ARSENIC

52. Scope

52.1 This test method describes the colorimetric determination of arsenic in sulfuric acid. The lower limit of determination is 0.01 ppm of arsenic.

53. Summary of Test Method

53.1 The arsenic is reduced to arsine gas, which is absorbed

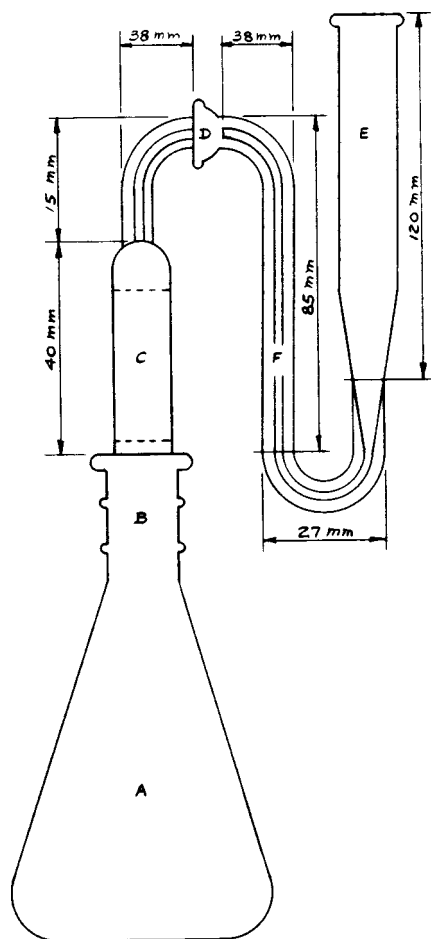

A—Generator, 125-mL Erlenmeyer  
 B—Standard-taper joint, 24/40  
 C—Scrubber  
 D—Ball joint, 12/2  
 E—Absorber, 12-mL heavy-wall, centrifuge tube with extended arm capillary connection, 2-mm inside diameter

FIG. 3 Arsine Generator

in a pyridine solution of silver diethyldithiocarbamate, forming a red-colored complex, the intensity of which is measured on a photometer.

54. Interference

54.1 Antimony is reduced to stibine which reacts with the reagent. The color produced is slightly different from that produced by arsine.

55. Apparatus

55.1 Absorption Cells, 2-cm light path.

NOTE 21—This procedure has been written for a cell having a 2-cm light path. Cells having other dimensions may be used, provided suitable adjustments can be made in the amounts of sample and reagents used.

55.2 Arsine Generator (Fig. 3).<sup>12</sup>

55.3 Flasks, volumetric, ground-glass stoppered, 10-mL.

55.4 Photometer—Any photoelectric spectrophotometer or filter photometer that will measure the absorbance of the solutions in the range from 500 to 575 nm.

56. Reagents (Note 22)

NOTE 22—All reagents and water used in the determination of arsenic by this test method should be very low in arsenic, particularly the zinc. If the NaNO<sub>3</sub> is high in arsenic, substitute 5 drops of HNO<sub>3</sub>(sp gr 1.42) for the 0.1 g of NaNO<sub>3</sub>.

56.1 Arsenic, Standard Solution (1 mL = 0.001 mg As)<sup>11</sup>—See Practice E 200.

56.2 Hydrochloric Acid (sp gr 1.189)—Concentrated hydrochloric acid (HCl).

56.3 Lead Acetate Impregnated Glass Wool—Dissolve 100 g of lead acetate trihydrate (Pb(C<sub>2</sub>H<sub>3</sub>O<sub>2</sub>)<sub>2</sub>·3H<sub>2</sub>O) in 200 mL of water. Saturate glass wool with the solution, remove excess solution, and vacuum dry at room temperature. Store the impregnated wool in a capped bottle.

56.4 Methyl Red Indicator Solution (5 g/L)—Dissolve 5 g of methyl red in 1 L of ethanol (95 %).<sup>8</sup>

56.5 Potassium Iodide Solution (100 g/L)—Dissolve 100 g of potassium iodide (KI) in about 750 mL of water, filter, and dilute to 1 L.<sup>8</sup>

56.6 Pyridine (C<sub>5</sub>H<sub>5</sub>N)—This reagent must be water white.

56.7 Silver Diethyldithiocarbamate—[(C<sub>2</sub>H<sub>5</sub>)<sub>2</sub>NCSAg] Solution (5 g/L of Pyridine)—Dissolve 1 g in 200 mL of pyridine. Store in an amber bottle. Prepare fresh monthly.

56.8 Sodium Chloride (NaCl).

56.9 Sodium Hydroxide Solution (100 g/L)—Dissolve 100 g of sodium hydroxide (NaOH) in water and dilute to 1 L with water.

56.10 Sodium Nitrate (NaNO<sub>3</sub>).

56.11 Stannous Chloride Solution (400 g/L)—Dissolve 40 g of stannous chloride dihydrate (SnCl<sub>2</sub>·2H<sub>2</sub>O) in a mixture of 25 mL of water and 75 mL of HCl (sp gr 1.19).

56.12 Zinc, 20-mesh.

57. Calibration

57.1 Into a series of the 125-mL generator flasks pipet 0, 1, 3, 5, 10, and 15 mL of standard arsenic solution (Note 23). Dilute each flask to 35 mL with water. Add 5 mL of HCl, 2 mL of KI solution, and 8 drops of SnCl<sub>2</sub> solution (Note 24). Mix the solutions and allow them to stand for 15 min to ensure complete reduction of the arsenic to the trivalent form.

57.2 Pack the scrubber tube for each flask with the lead acetate impregnated glass wool and moisten with 1 drop of lead acetate solution. Lubricate the standard taper and ball-and-socket joints with lubricant<sup>13</sup> and assemble the scrubber-absorber unit. Do not attach scrubber-absorber unit to the

<sup>12</sup> Fisher Scientific Co. No. 01-405 has been found satisfactory for this purpose.

<sup>13</sup> Lubricant must not be soluble in pyridine. K-Y lubricating jelly (a trademarked product of Johnson and Johnson) has been found satisfactory for this purpose.



generator flask. Pipet 3 mL of the silver diethyldithiocarbamate solution into each absorber section. By means of a powder funnel, quickly add 3.0 g of zinc to each flask. Immediately attach the scrubber-absorber unit to the generator flask and let stand for 30 min.

57.3 Transfer the solutions from the absorber sections to separate, dry 10-mL volumetric flasks. Rinse out each absorber section with pyridine and transfer the washings to the same flask. Make to volume with pyridine and mix.

57.4 Measure the absorbances of the solutions using a photometer with a wavelength setting of 560 nm or a filter photometer equipped with a filter in the range from 500 to 575 nm, adjusting the photometer to read zero absorbance for the reagent blank.

57.5 Plot on coordinate paper the absorbances of the calibration solutions against milligrams of arsenic present per 10 mL.

NOTE 23—All new glassware must be cleaned with hot concentrated H<sub>2</sub>SO<sub>4</sub>, rinsed with water, rinsed with acetone, and dried. If the glassware is reserved for arsenic determinations exclusively, the H<sub>2</sub>SO<sub>4</sub> may be omitted in subsequent washings.

NOTE 24—Too great an excess of SnCl<sub>2</sub> causes loss of arsenic by reducing it to elemental arsenic.

**58. Procedure**

58.1 From a graduated cylinder, transfer about 50 mL of the sample to a 100-mL beaker. Record the number of millilitres taken, *W*. Add about 0.1 g of NaNO<sub>3</sub> and 0.1 g of NaCl and evaporate on a hot plate in the hood to almost dryness.

58.2 Wash the sample into a generator flask with small portions of water. Do not exceed 30 mL total volume.

58.3 Add 1 drop of methyl red indicator solution and add NaOH solution dropwise until the solution is just alkaline (yellow). Dilute to 35 mL with water.

58.4 Add 5 mL of HCl, 2 mL of KI solution, and 8 drops of SnCl<sub>2</sub> solution. Mix the solution and allow it to stand for 15 min.

58.5 Pack the scrubber tube for the flask with the lead acetate impregnated glass wool and moisten with 1 drop of lead acetate solution. Lubricate the standard taper and ball-and-socket joints with lubricant and assemble the scrubber-absorber unit. Do not attach scrubber-absorber unit to the generator flask. Pipet 3 mL of the silver diethyldithiocarbamate solution into the absorber section. By means of a powder funnel, quickly add 3.0 g of zinc to the flask. Immediately attach the scrubber-absorber unit to the generator flask and let stand for 30 min.

58.6 Transfer the solution from the absorber section to a dry 10-mL volumetric flask. Rinse out the absorber section with pyridine and transfer the washings to the same flask. Make to volume with pyridine and mix.

58.7 Prepare a blank solution using all reagents but omitting the sample.

58.8 Determine the absorbance of the sample at the same wavelength used for the calibration curve, blanking the instrument at zero percent absorbance with the blank solution. Determine from the calibration curve the milligrams of arsenic that correspond to the observed absorbance.

NOTE 25—If the color obtained is too intense to fall within the range of the calibration curve, repeat with a smaller sample.

**59. Calculation**

59.1 Calculate the parts per million arsenic as follows (Note 26):

$$\text{Arsenic, ppm} = \frac{M \times 1000}{W \times \text{sp gr}} \tag{9}$$

where:

*M* = arsenic found from calibration curve, mg, and

*W* = sample, mg.

NOTE 26—If this value is less than 0.01 ppm, report as less than 0.01 ppm.

**60. Report**

60.1 Report the parts per million of arsenic to the nearest 0.01 ppm.

**61. Precision and Bias**

61.1 The following criteria should be used for judging the acceptability of results (see Note 27):

61.1.1 *Repeatability (Single Analyst)*—The standard deviation for a single determination has been estimated to be the value in Table 3 at the indicated degrees of freedom. The 95 % limit for the difference between two such runs is given in Table 3.

61.1.2 *Laboratory Precision (Within-Laboratory, Between-Days Variability), Formerly Called Repeatability*—The standard deviation of results (each the average of duplicates), obtained by the same analyst on different days, has been estimated to be the value in Table 3 at the indicated degrees of freedom. The 95 % limit for the difference between two such averages is given in Table 3.

61.1.3 *Reproducibility (Multilaboratory)*—The standard deviation of results (each the average of duplicates), obtained by analysts in different laboratories, has been estimated to be the value in Table 3 at the indicated degrees of freedom. The 95 % limit for the difference between two such averages is given in Table 3.

NOTE 27—These precision estimates are based on an interlaboratory study of analyses performed in 1967 on two samples containing approximately 0.06 and 0.6 ppm arsenic. One analyst in each of eight laboratories performed duplicate determinations and repeated one day later, for a total of 32 determinations.<sup>9</sup> Practice E 180 was used in developing these precision estimates.

One sample, containing approximately 0.01 ppm arsenic, was analyzed by one analyst in each of eight laboratories for a total of 32

**TABLE 3 Arsenic Precision Values**

Level, ppm	Repeatability			Laboratory Precision			Reproducibility		
	Standard Deviation	Degrees of Freedom	95 % Limit	Standard Deviation	Degrees of Freedom	95 % Limit	Standard Deviation	Degrees of Freedom	95 % Limit
0.06	0.0069	16	0.02	0.0052	8	0.01	0.018	7	0.05
0.60	0.040	14	0.11	0.028	7	0.08	0.134	6	0.37

determinations. Data produced at this level were erratic because the arsenic content was at the limit of sensitivity of this test method.

61.2 Since there is no accepted reference material for determining the bias for measuring the arsenic content of sulfuric acid, the bias of this test method has not been determined.

## **62. Keywords**

62.1 acidity; total; analysis; arsenic; Baumé gravity; iron; nonvolatile matter; sulfur dioxide; sulfuric acid

*The American Society for Testing and Materials takes no position respecting the validity of any patent rights asserted in connection with any item mentioned in this standard. Users of this standard are expressly advised that determination of the validity of any such patent rights, and the risk of infringement of such rights, are entirely their own responsibility.*

*This standard is subject to revision at any time by the responsible technical committee and must be reviewed every five years and if not revised, either reapproved or withdrawn. Your comments are invited either for revision of this standard or for additional standards and should be addressed to ASTM Headquarters. Your comments will receive careful consideration at a meeting of the responsible technical committee, which you may attend. If you feel that your comments have not received a fair hearing you should make your views known to the ASTM Committee on Standards, 100 Barr Harbor Drive, West Conshohocken, PA 19428.*