



Standard Test Method for Determination of Low Levels of Water in Liquid Chlorine By Infrared Spectrophotometry¹

This standard is issued under the fixed designation E 1754; the number immediately following the designation indicates the year of original adoption or, in the case of revision, the year of last revision. A number in parentheses indicates the year of last reapproval. A superscript epsilon (ϵ) indicates an editorial change since the last revision or reapproval.

^{ε1} NOTE—Editorial changes were made in August 2001.

1. Scope

1.1 This test method covers the determination of the content of water in liquid chlorine in the concentration range of 0.5 to 15 mg/kg (ppm).

1.2 *This standard does not purport to address all of the safety concerns, if any, associated with its use. It is the responsibility of the user of this standard to establish appropriate safety and health practices and determine the applicability of regulatory limitations prior to use.* See Section 7 for specific hazards statements.

1.3 Review the current Material Safety Data Sheets (MSDS) for detailed information concerning toxicity, first aid procedures, and safety precautions.

2. Referenced Documents

2.1 ASTM Standards:

D 1193 Specification for Reagent Water²

E 180 Practice for Determining the Precision of ASTM Methods for Analysis and Testing of Industrial Chemicals³

E 806 Test Method for Carbon Tetrachloride and Chloroform in Liquid Chlorine by Direct Injection (Gas Chromatographic Procedure)³

2.2 Federal Standards:⁴

49 CFR 173 Code of Federal Regulations Title 49 Transportation: Shippers' General Requirements for Shipments and Packaging, including Sections:

173.304 Charging of Cylinders with Liquefied Compressed Gas

173.314 Requirements for Compressed Gases in Tank Cars

173.315 Compressed Gases in Cargo Tanks and Portable Tank Containers

3. Summary of Test Method

3.1 A sample of liquid chlorine is introduced into a special infrared cell and maintained as a liquid under its own pressure. A spectrometer scans from 400 to 4400 wavenumbers of the infrared transmission spectrum of liquid chlorine. This spectrum is then ratioed to one obtained of the nitrogen-filled infrared cell previously. The ratioed spectrum is converted to absorbance, and the net absorbance of the water band at 1596 wavenumbers, relative to a reference at 1663 wavenumbers, is determined. The amount of water corresponding to this net absorbance is determined from a calibration curve prepared from the infrared absorbances of standards that contain known concentrations of water in liquid chlorine.

4. Significance and Use

4.1 Trace amounts of water may be detrimental to the use of chlorine in some applications. The amount of water in the chlorine must be known to prevent problems during its use.

5. Apparatus

5.1 *Infrared Spectrometer*, capable of measurements in the 1600 wavenumber region. An FTIR with 4 wavenumber resolution is the instrument of choice, but dispersive instruments may also be used to achieve similar results.

5.2 *Special Infrared Cell* (see Fig. 1), neither cell size nor pathlength are critical to the analysis, but sensitivity and limit of detection are dependent on pathlength. The concentration range reported in the scope is achievable with a 60-mm pathlength cell constructed with:

5.2.1 *Hastelloy C and 316 Stainless Steel Stock*, suitable for machining.⁵

¹ This test method is under the jurisdiction of ASTM Committee E15 on Industrial and Specialty Chemicals and is the direct responsibility of Subcommittee E15.02 on Product Standards.

Current edition approved Sept. 10, 1995. Published December 1995.

² *Annual Book of ASTM Standards*, Vol 11.01.

³ *Annual Book of ASTM Standards*, Vol 15.05.

⁴ Available from Superintendent of Documents, Government Printing Office, Washington, DC 20402.

⁵ Available from Collins Instrument Co. Inc., P.O. Drawer 938 Angleton, TX 77516-0938.

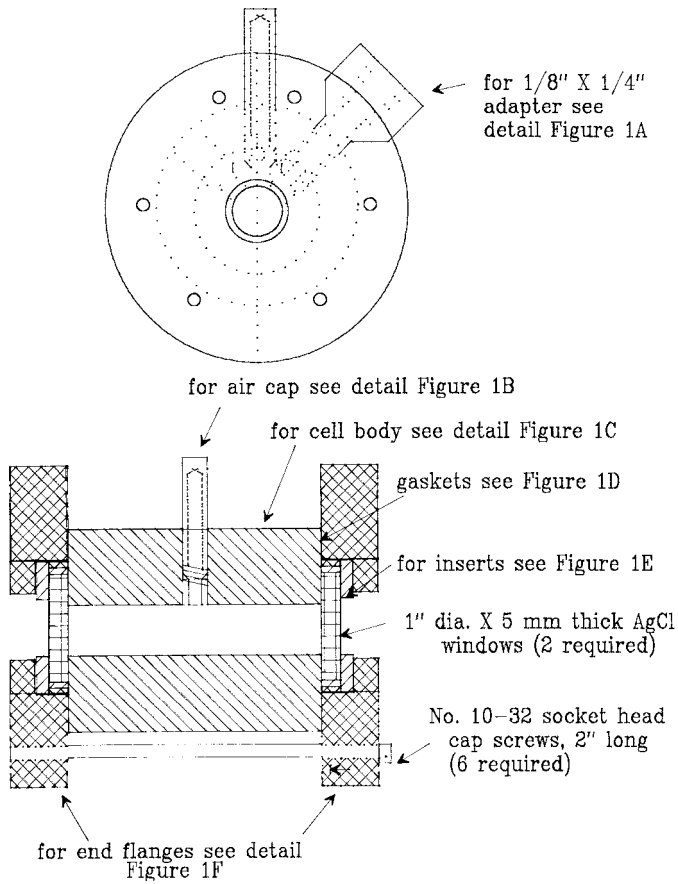

NOTE 1—Drawing not to scale.
FIG. 1 Infrared Cell

5.2.2 Silver Chloride Windows, 0.5 by 2.5 cm.⁶

1/8" X 1/4"
 material: Hastalloy C
 2 required

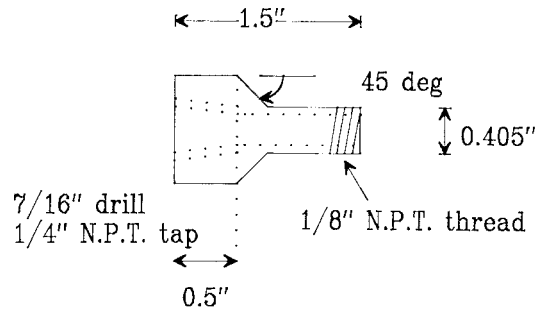
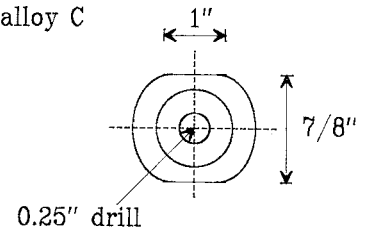

if desired, pipe adapters may be welded

FIG. 1(a) Pipe Adapter

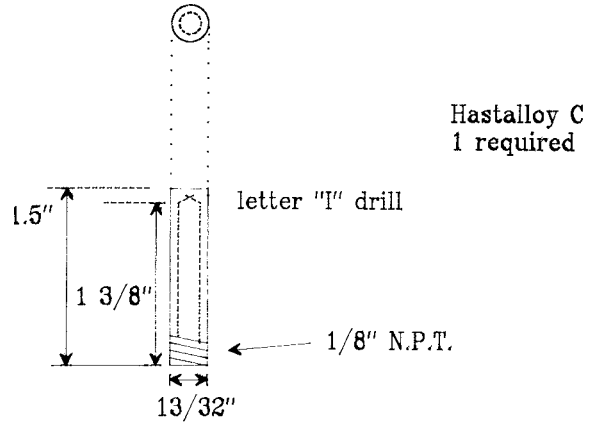

FIG. 1(b) Air Cap Detail

⁶ Available from Harshaw Chemical Co., 6801 Cochran Road, Solon, OH 44139.

Letter "R" drill 7/16" deep

Letter "T" drill thru
1/8" N.P.T. tap

3 holes as shown

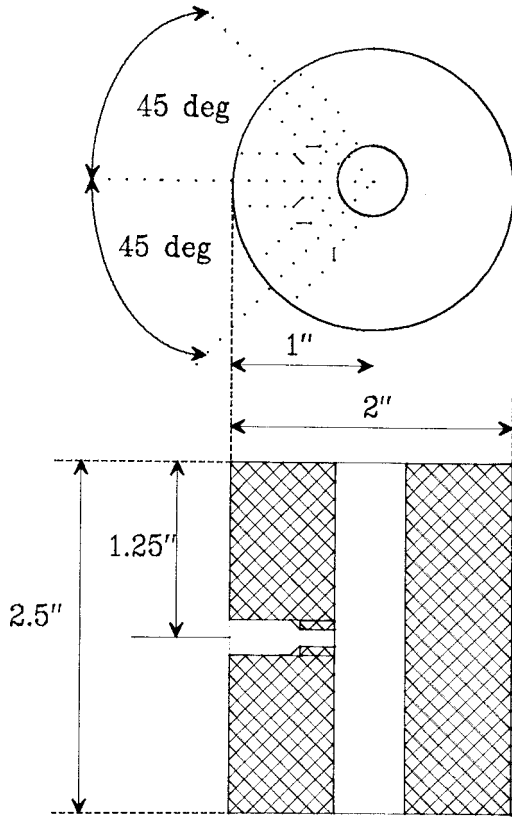
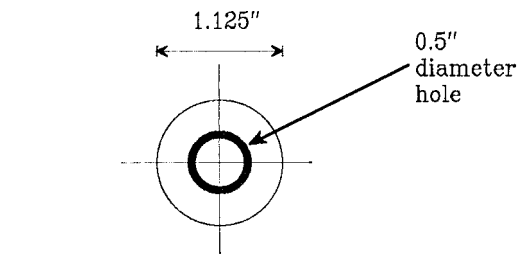

FIG. 1(c) Body Detail



DuPont Kalrez Perfluoroelastomer
2 required
material about 0.030" thick

FIG. 1(d) Gasket Detail

Material: Teflon
2 required

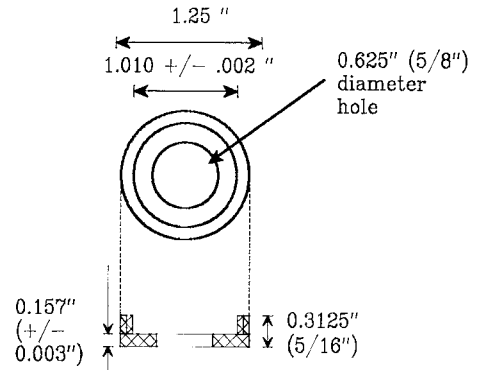

FIG. 1(e) Insert Detail

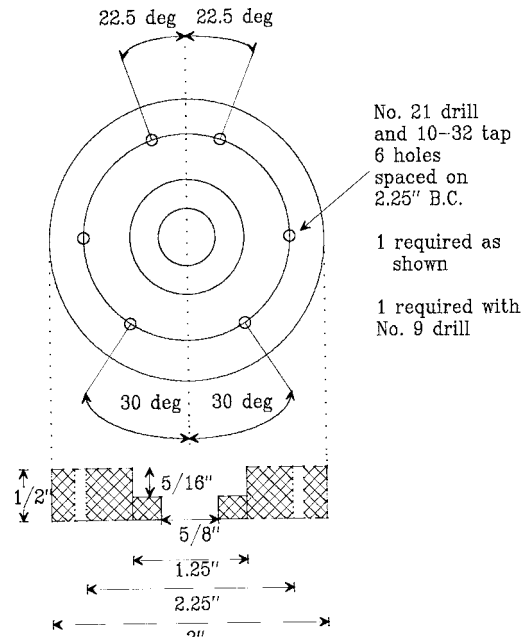

FIG. 1(f) Flange Detail

5.2.3 *Perfluoroelastomer Sheet*, 0.030 in. thickness.⁷

5.3 *Ball Valves*, Monel 1/4 in. valve with pipe and 1/4 in. tube ends.

5.4 *Needle Valves*, nickel or Monel 1/4 in. valve with pipe and 1/4 in. tube ends.

5.5 *Sample Cylinder Assembly* (see Fig. 2), consisting of:

5.5.1 *Sample Cylinder*, nickel, Monel, or tantalum; 400 to 1000 mL capacity, double-ended, with valves at each end, specially cleaned. Cylinders with both valves at one end and with a dip tube on one valve have been found to be satisfactory. Another option is to construct special cylinders containing a septum fitting on one end.

NOTE 1—A procedure for cleaning cylinders and valves, for use with liquid chlorine, is given in Test Method E 806, Appendix X2.

5.5.2 *Needle and Ball Valve*, nickel body, having packing resistant to liquid chlorine.⁸ If nickel valves are not available, Monel valves may be used.

⁷ Available from I.E. DuPont de Nemours and Co., Wilmington, DE 19898.

⁸ Packing made from TEFLON®, VITON®, or KEL-F® has been found satisfactory for this purpose.

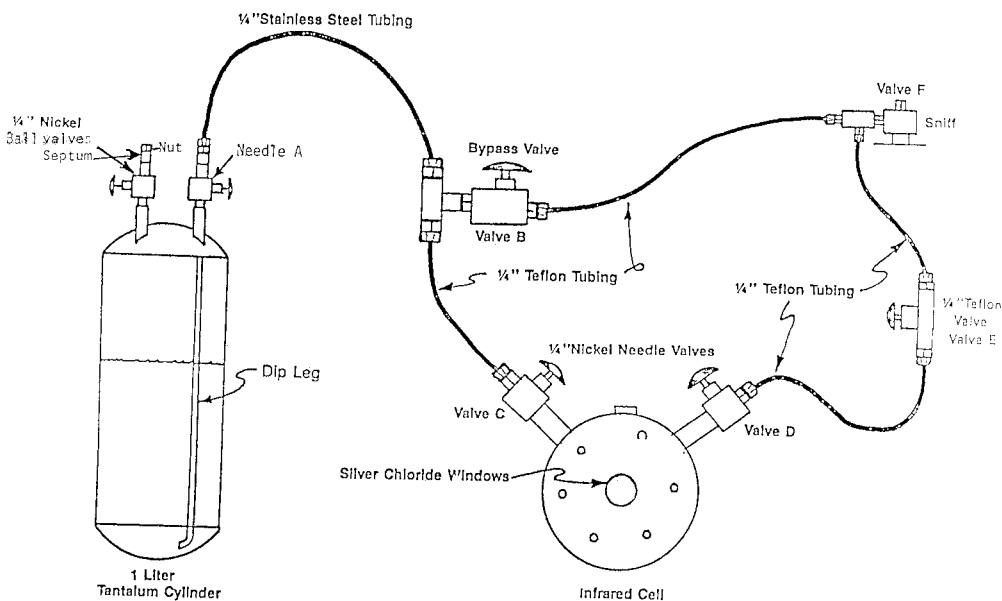

FIG. 2 Sample Cylinder Assembly

5.5.3 *Septum*, inserted into a 1/4 in. nut.

5.5.4 *Glove Bag or Dry Box*, purged with dry nitrogen (less than 5 ppm water vapor).

5.5.5 *Fittings*, for transferring chlorine from one cylinder to another.

5.5.6 *0 to 10 µL Syringe and 0 to 25 µL Syringe*, 26 gage needle.

5.5.7 *Dewar Flask*, of sufficient size to hold a cylinder surrounded by dry ice and methylene chloride. The Dewar flask should be supported by a wooden holder for safety purposes.

5.5.8 *Hygrometer*, capable of measuring moisture as low as 5 ppm in glove bag or dry box.

5.6 *Silicone Rubber Septa*.

5.7 *Mechanical Shaker*.

5.8 *Drying Oven*.

6. Reagents

6.1 *Chlorine*, liquid with less than 5 ppm water.

6.2 *Methylene Chloride* (CH_2Cl_2).⁹

6.3 *Dry Ice* (CO_2).

6.4 *Dry Nitrogen*, (<5 ppm water) to purge glove bag or dry box and test equipment.

7. Hazards

7.1 *Safety Precautions*:

7.1.1 Chlorine is a corrosive and toxic material. A well-ventilated fume hood should be used to house all test equipment, except the infrared spectrophotometer, when this material is analyzed in the laboratory.

7.1.2 The analysis should be attempted only by persons who are thoroughly familiar with the handling of chlorine, and even

an experienced person should not work alone. The analyst must be provided with adequate eye protection (chemical goggles are recommended) and an approved chlorine respirator. Splashes of liquid chlorine destroy clothing and if such clothing is next to the skin, will produce irritation and burns.

7.1.3 When sampling and working with chlorine out of doors, people downwind from such operations should be warned of the possible release of chlorine.

7.1.4 It is recommended that means be available for disposal of excess chlorine in an environmentally safe and acceptable manner. If chlorine cannot be disposed of in a chlorine consuming process, a chlorine absorption system should be provided. When the analysis and sampling regimen requires an initial purging of chlorine from a container, the purged chlorine should be similarly handled. Purging to the atmosphere should be avoided.

7.1.5 In the event chlorine is inhaled, first aid should be summoned immediately.

8. Sampling

8.1 Sampling points should also be chosen with care. Ensure that the sample point is associated with flowing chlorine, and is not near a "dead leg" where the concentrations of impurities in the chlorine will never change because the chlorine never moves. If sampling through secondary piping, that piping should be purged well with nitrogen or dry air before being blocked in. Otherwise, temperature variations can result in water vapor condensing inside the piping to contaminate the chlorine sample when it is grabbed. Finally, sampling should be done at a sample point representative of the chlorine needing to be analyzed.

8.1.1 Sampling from tank cars, barges, storage tanks, and large cylinders presents unique problems. Each facility, however, must be capable of delivering a liquid sample (not gas). Acceptable samples can be obtained by sampling in accordance

⁹ This reagent is used for cooling purposes only.

with the Chlorine Institute Pamphlet No. 77, "Sampling Liquid Chlorine".¹⁰

8.2 It is recommended that samples be collected from these facilities in the sample cylinder assembly listed in 5.5. Proper and safe sampling techniques must be followed. The cylinder must contain at least 75 % by volume of liquid chlorine (less than 25 % vapor space).

NOTE 2—Do not allow the cylinder to become liquid full. Tare the cylinder, fill with water, and re-weigh to determine the weight of water in the cylinder. Multiply this weight by 1.56 (the assumed specific gravity of liquid chlorine) and by 0.75 to obtain the weight of chlorine to fill the cylinder 75 % full. Example: The cylinder holds 1000 g of water (1000 mL, assuming a specific gravity of 1.0). The filled cylinder will hold 1560 g of chlorine, and at 75 % of capacity, it will contain 1170 g of chlorine.

8.3 The sample cylinders should be thoroughly dried by placing in an oven at 105°C for at least 6 h or preferably overnight; the dip tubes are not heated, place them in a desiccator. Valves are also placed in the oven, but not as a part of the cylinder (packings are resistant to this temperature). After this treatment, the cylinders are cooled with plant air or N₂ having <5 ppm moisture. The valves are removed, placed in a desiccator with a suitable drying agent, and cooled to room temperature.

9. Preparation of Standards for Calibration

9.1 Obtain four clean, evacuated sample cylinders. Only cylinders that have been properly pressure-tested should be used. Equip three with a ball valve and a needle valve, label these Cylinders No. 2 through No. 4 and record weight to the nearest gram. Equip the fourth cylinder with two needle valves, weigh to the nearest gram, record, and label as No. 1. Once it contains chlorine, it will be used to purge the infrared cell before standards are loaded. Use caps on all valves. If dip tubes are used, attach the dip tube to the needle valve. Check the hygrometer to make sure the atmosphere in the glove bag or dry box contains <5 ppm moisture before performing any transfers of chlorine.

9.2 Load the four cylinders with liquid chlorine. The liquid chlorine should contain less than 5 ppm water. All cylinders must contain at least 75 % by volume liquid chlorine (less than 25 % vapor space). All cylinders should be weighed to the nearest gram and recorded to determine the weight of chlorine in each cylinder (Note 2). Place the filled cylinders into the glove bag or dry box inside the hood. Place all fittings, tools and equipment, including the purged infrared cell, in the glove bag or dry box. Wait until the hygrometer in the glove bag or dry box is reading <5 ppm moisture before proceeding.

9.3 Remove the cap on Valve A of Cylinder No. 1 and blow with N₂ to remove any trapped moisture. Do this each time a connection is made. Then connect the cylinder and the special infrared cell to the filling apparatus (see Fig. 2) in such a way that the liquid chlorine will flow into the cell and that the valves on all parts of the apparatus are closed prior to filling the cell. For the following operations, refer to 7.1.4 on venting chlorine.

9.4 Open Valve F and then Valve A. Flush the filling apparatus by partially opening Valve B for a few seconds and then closing it. Leave Valve A open.

9.4.1 Open Valves E and C. Flush the cell by partially opening Valve D and observing flow, then close Valve C and then Valve D.

9.5 Fill the infrared cell by opening Valve C and observe the filling of the cell windows. Close Valve C and empty the cell by opening Valve D. Close Valve D.

9.6 Fill and empty the cell once more, as above.

9.6.1 Close Valve A and open Valve B, to purge the filling apparatus, then close.

9.7 Remove the cylinder. Connect Cylinder No. 2 to the filling apparatus after blowing Valve A with N₂. Make sure that the cylinder is connected to the apparatus in such a way that the liquid chlorine will flow into the cell and that the valves on all parts of the apparatus are closed prior to attempting to fill the cell. For the following operations, refer to 7.1.4 on venting chlorine. Repeat 9.4 to 9.6.

9.8 Fill the cell by opening Valve C. Close Valve C and invert the cell to ensure complete filling of the cell window and then close Valve A.

9.9 Vent the residual chlorine from the filling apparatus by opening Valve B and then open Valve C a little and dump a small amount of chlorine from the inverted cell, then quickly close. The cell window should have about 1/5 vapor space when inverted. Then close Valves B and E.

9.10 Allow the cell to come to ambient temperature. Before removing the cell from the filling apparatus, check again for adequate vapor space in the inverted cell window. If no vapor space is seen, open Valve B and quickly open and close Valve C a little to dump some more chlorine. Make sure that no more than 1/4 to 1/5 of the cell window is vapor space when the cell is inverted. Remove Cylinder No. 1 and No. 2 and record their weights.

9.11 Place the infrared cell in the spectrometer and scan in transmission mode from 400 to 4400 wavenumbers at 4-wavenumber resolution. Ratio this spectrum to a spectrum taken of the infrared cell filled with nitrogen. Then convert the ratioed transmission spectrum to absorbance and measure the net absorbance of the band at 1596 wavenumber relative to a reference at 1663 wavenumbers.

9.12 Repeat the operations above (9.4-9.11, omit 9.6.1) with chlorine Cylinders No. 3 and No. 4.

9.13 Low concentrations of water will be present in each cylinder prior to introduction of additional water via a microlitre syringe. Infrared absorbance spectra of the three cylinders of liquid chlorine obtained at the same time should agree within 20 %. For example, absorbance of water at 1596 cm⁻¹ less the reference at 1663 cm⁻¹ for Cylinder No. 1 yields a peak height of 25 mAU. The same measurement for Cylinder No. 2 is 30 mAU, and for Cylinder No. 3 is 20 mAU.

9.14 Add approximately 500 mL of methylene chloride to the Dewar flask supported by a wooden holder. Add small pieces of dry ice to the Dewar flask, then place the wooden holder and Dewar flask in the glove bag or dry box.

9.15 To prevent overflowing the Dewar flask, slowly lower Cylinder No. 2 into the methylene chloride/dry ice mixture for

¹⁰ Available from The Chlorine Institute, Inc., 2001 L St. NW, Washington, DC 20036.

cooling. The mixture should cover about $\frac{2}{3}$ of the cylinder.

9.16 Calculate the volume of water in microlitres to add to the cylinder to increase the water in the chlorine 5 mg/kg. Use the weight of the cylinder after filling the cell to determine the weight of the chlorine remaining in the cylinder. Assume the density of water to be 1.0 g/mL.

9.17 In the glove bag or dry box, fill the 10- μ L syringe with the volume of water calculated in 9.16. Remove the cap on the ball valve and blow any trapped moisture with N_2 . Replace the cap with a septum and blow the septum with N_2 . Carefully open the ball valve and inject the water from the syringe through the septum into the vapor space of Cylinder No. 2, then quickly close the ball valve. Two people may be needed to do the spiking and opening and closing of the ball valve.

NOTE 3—This test method has been successfully applied using special sample cylinders constructed with a septum holder at one end and using Viton septa. This allows for the water to be injected directly into the liquid chlorine in the cylinder. When this technique is used the water injection must be done at room temperature, as cooling the cylinder causes the water to freeze in the syringe and also makes it more difficult to penetrate the septum.

9.17.1 Remove the cylinder from the Dewar flask and allow to come to ambient temperature in the glove bag or dry box.

9.18 Place the cylinder on a mechanical shaker and shake for 72 h to ensure complete dissolution of the water in the liquid chlorine.

9.19 Calculate the added concentration of water as milligrams per kilogram (parts per million) in the spiked standard.

9.20 Spike Cylinders Nos. 3 and 4 with approximately the same amount of water for replication purposes by repeating 9.14-9.19.

10. Preparation of Calibration Curve

10.1 Place the four cylinders in the glove bag or dry box and when the moisture in the bag or box is minimized according to the hygrometer, remove the cap on Valve A of Cylinder No. 1 and blow with N_2 to remove any trapped moisture. Attach the cylinder and the special infrared cell to the filling apparatus in such a way that the liquid chlorine will flow into the cell. Make sure that all the valves on all parts of the apparatus are closed prior to attempting to fill the cell. For the following operations, refer to 7.1.4 on venting chlorine.

10.2 Open Valve F and then Valve A. Flush the filling apparatus by partially opening Valve B for a few seconds and then closing it. Leave Valve A open.

10.2.1 Open Valves E and C. Flush the cell by partially opening Valve D and observing flow, close Valve C and then Valve D.

10.3 Fill the infrared cell by opening Valve C and observe the filling of the cell window. Close Valve C and empty the cell by opening Valve D. Close Valve D.

10.4 Fill and empty the cell once more, as above.

10.4.1 Close Valve A and open Valve B to purge the filling apparatus.

10.5 Disconnect Cylinder No. 1 from the filling apparatus (see Fig. 2). Connect the standard Cylinder No. 2 to the filling apparatus in such a way that the liquid chlorine will flow into the cell and that all the valves on all parts of the apparatus are closed prior to attempting to fill the cell. For the following

operations, refer to 7.1.4 on venting chlorine. Repeat 10.2-10.4. Omit 10.4.1.

10.6 Fill the cell and invert. Observe the cell windows to ensure complete filling. Close Valve C, and then Valves A and E.

10.7 Vent the residual chlorine from the filling apparatus by opening Valve B and then open Valve C a little and dump a small amount of chlorine from the inverted cell. Close quickly. The cell window should have about $\frac{1}{5}$ vapor space when inverted. Then close Valve B.

10.8 Allow the cell to come to ambient temperature in the glove bag or dry box and invert to check again for vapor space in the cell window. Dump more chlorine if there is no vapor space by opening Valve B and while the cell is inverted quickly open and close Valve C.

10.9 Remove the cylinder and cell from the filling apparatus. Weigh the cylinder and place the cell in the spectrometer and scan in transmission mode from 400 to 4400 wavenumbers.

10.10 Most infrared spectrometers now permit a “ratio” of one transmission spectrum to another to be obtained. Calibration curves herein are generated in this manner; spectra of those obtained after spiking (10.9) are ratioed to those obtained before spiking (9.11). This ratioed transmission spectrum is then converted to absorbance units. A “zero” water spectrum is generated by subtraction of one cylinder’s spectrum from that of a second cylinder grabbed at the same time. Also determine the standard deviation among the water absorbance of the three samples analyzed from each cylinder.

10.11 Empty the four cylinders of liquid chlorine, purge with nitrogen, and repeat 9.1-10.10 for 10 mg/kg and 15 mg/kg. Standards below 10 mg/kg (ppm) require the 10-microlitre syringe. Standards between 10 and 25 mg/kg (ppm) require the 25- μ L syringe. A total of three standards should be prepared containing three different levels of water after spiking (5, 10 and 15 mg/kg) by following 9.4-9.18.

10.12 Plot the absorbance versus known water concentration for each analysis from each cylinder. Use least-squares analysis to obtain a linear fit through the points generated. Report the correlation coefficient, slope and intercept determined.

10.13 In some cases, analysis of chlorine from some cylinders will not indicate successful “spiking.” The water concentration will not appear to vary much from its prespiking value. A likely cause is that the water was delivered into the space between the valve and the septum but never actually reached the cylinder itself. Discard the results and repeat the spiking and measurement procedures using another cylinder. A plot with absorbance on the Y-axis and H_2O on the X-axis is generated. The slope is the slope of this line, and is also the response factor for water. The intercept indicates whether the line passes through the origin, and the correlation coefficient indicates the goodness of fit and should be greater than 0.95. This correlation coefficient is less than 0.99 because the error associated with generating the standard with a known concentration of water.

10.14 Cylinder Nos. 2, 3, and 4 must be scanned three times each. This increases the precision of the calibration curve and

provides a measure of the variation in sampling the contents of each cylinder.

11. Procedure

11.1 Within a nitrogen-purged glove bag or dry box in a hood, connect the cylinder containing the sample of liquid chlorine and the special infrared cell to the filling apparatus (see Fig. 2). Make sure that all the valves on all parts of the apparatus are closed prior to attempting to fill the cell. For the following operations, refer to 7.1.4 on venting chlorine.

11.2 Open Valve F and then Valve A. Flush the filling apparatus by partially opening Valve B for a few seconds, then closing it. Leave Valve A open.

11.2.1 Open Valves E and C. Flush the cell by partially opening Valve D and observing flow, close Valve C and then Valve D.

11.3 Fill the infrared cell by opening Valve C and observe the filling of the cell window. Close Valve C and empty the cell by opening Valve D. Close Valve D.

11.4 Fill and empty the cell once more, as above.

11.5 Fill the cell by opening Valve C. Close Valve C, invert to ensure complete filling by observing the cell window, and then close Valve A.

11.6 Vent the residual chlorine from the filling apparatus by opening Valve B and dump some of the liquid chlorine from the inverted cell from Valve C, then quickly close Valve C and Valve B. There should be about $\frac{1}{5}$ vapor space in the inverted cell window.

11.7 Allow the cell to come to ambient temperature and invert the cell again to see that there is still vapor space in the cell window. If no vapor space is seen, open Valve B and quickly open and close Valve C. Make sure that no more than $\frac{1}{4}$ to $\frac{1}{5}$ of the cell window is vapor space when the cell is inverted.

11.8 Remove the cylinder and the cell from the filling apparatus. Place the cell in the spectrometer. Scan the infrared spectrum in transmission mode from 400 to 4400 wavenumbers at 4-wavenumber resolution. Ratio this spectrum to a spectrum of the nitrogen-filled infrared cell. Convert this ratioed spectrum to absorbance units. Then measure the “net absorbance” of the band at 1596 wavenumbers with reference to the absorbance at 1663 wavenumbers.

11.9 Small quantities of water vapor may be present in infrared spectrum at 1600 to 1618 wavenumbers. This water

vapor does not interfere with analysis of trace liquid water, since a baseline point chosen for correction at 1663 wavenumbers is between the two sets of water vapor bands. The maximal liquid water absorbance occurs at 1596 wavenumbers, the wavelength used throughout these measurements. The water content of each standard cylinder was analyzed three times on the FTIR.

11.10 From the calibration curve, determine the milligrams per kilogram (parts per million) of water present in the sample.

12. Report

12.1 Report the water content to the nearest milligrams per kilogram (parts per million) of water present in the sample in the cell.

13. Precision and Bias

13.1 The detection limit was determined as three times the standard deviation of the water absorbance before spiking. This corresponds to 250 ppb, although it may vary somewhat from instrument to instrument. This value should be similar to the intercept determined from the least-squares analysis of the calibration curve, although the intercept error may be high due to imprecision in standard preparation. The correlation coefficient may be under 0.99, reflecting the accuracy in this calibration which is largely determined by the standard preparation. Relative standard error in the slope of the calibration curve should be approximately 6%. However, the larger intercept error (approximately $300 \text{ ppb} \pm 500 \text{ ppb}$) may introduce up to 1 ppm error.

13.2 Only photometric error, which arises in measurement of absorbencies above 700 mAU, limits extension of this calibration to higher concentrations of water in liquid chlorine. This assumes, of course, that no chemical reactions occur to modify the amount of water available for analysis. An infrared cell of similar pathlength to the one described here permits determination of as much as 50 ppm water with an accuracy of approximately 4 ppm (1 ppm offset due to uncertainty in intercept ± 3 due to 6% relative error).

13.3 Repeatability is pending.

14. Keywords

14.1 FTIR; IR; infrared spectrophotometry; liquid chlorine; water

The American Society for Testing and Materials takes no position respecting the validity of any patent rights asserted in connection with any item mentioned in this standard. Users of this standard are expressly advised that determination of the validity of any such patent rights, and the risk of infringement of such rights, are entirely their own responsibility.

This standard is subject to revision at any time by the responsible technical committee and must be reviewed every five years and if not revised, either reapproved or withdrawn. Your comments are invited either for revision of this standard or for additional standards and should be addressed to ASTM Headquarters. Your comments will receive careful consideration at a meeting of the responsible technical committee, which you may attend. If you feel that your comments have not received a fair hearing you should make your views known to the ASTM Committee on Standards, at the address shown below.

This standard is copyrighted by ASTM, 100 Barr Harbor Drive, PO Box C700, West Conshohocken, PA 19428-2959, United States. Individual reprints (single or multiple copies) of this standard may be obtained by contacting ASTM at the above address or at 610-832-9585 (phone), 610-832-9555 (fax), or service@astm.org (e-mail); or through the ASTM website (www.astm.org).