



Standard Test Method for Saybolt Furol Viscosity of Bituminous Materials at High Temperatures¹

This standard is issued under the fixed designation E 102; the number immediately following the designation indicates the year of original adoption or, in the case of revision, the year of last revision. A number in parentheses indicates the year of last reapproval. A superscript epsilon (ϵ) indicates an editorial change since the last revision or reapproval.

1. Scope

1.1 This test method covers the empirical procedures for determining the Saybolt Furol viscosities of bituminous materials at specified temperatures between 248 and 464°F (120 and 240°C).

1.2 The values stated in inch-pound units are to be regarded as the standard.

1.3 *This standard does not purport to address all of the safety concerns, if any, associated with its use. It is the responsibility of the user of this standard to establish appropriate safety and health practices and determine the applicability of regulatory limitations prior to use.* See 8.1.

2. Referenced Documents

2.1 ASTM Standards:

D 88 Test Method for Saybolt Viscosity²

D 92 Test Method for Flash and Fire Points by Cleveland Open Cup³

D 140 Practice for Sampling Bituminous Materials²

E 1 Specification for ASTM Thermometers⁴

E 11 Specification for Wire-Cloth Sieves for Testing Purposes⁵

3. Terminology

3.1 Definitions:

3.1.1 *Furol*—an acronym of “Fuel and road oils.”

3.1.2 *Saybolt Furol viscosity*—the corrected efflux time in seconds of 60 mL of sample flowing through a calibrated Furol orifice under specified conditions. The viscosity value is reported in Saybolt Furol seconds, abbreviated SFS, at a specified temperature.

4. Summary of Test Method

4.1 The efflux time in seconds of 60 mL of sample, flowing through a calibrated orifice, is measured under carefully

controlled conditions. The time is corrected by an orifice factor and reported as the viscosity of the sample at that temperature.

5. Significance and Use

5.1 This test method is useful in characterizing certain bituminous materials, as one element in establishing uniformity of shipments and sources of supply.

5.2 This test method is an extension of Test Method D 88.

6. Apparatus

6.1 *Saybolt Furol Viscometer and Bath*, as shown and described in Test Method D 88, Fig. 1 and Annex 1. An external heater may also be used, but if so, it shall be more than 2 in. (51 mm) from the viscometer. An aluminum-block, constant-temperature bath is also acceptable, and no stirring device is required with this type of bath.

6.2 *Displacement Ring*, as shown in Fig. 1, constructed of the same corrosion-resistant metal as the viscometer.

6.3 *Cover*—A metal cover for the viscometer, cylindrical with a flat top, approximately 2¼ in. (57 mm) in diameter and ¼ in. (7 mm) deep (Note 1). One hole slightly larger than the diameter of a viscosity thermometer shall be drilled in the center of the cover, and two smaller holes to permit the vertical rods of the displacement ring to pass through the cover.

NOTE 1—The cover of a 3-oz (90-mL) Gill-style ointment box fulfills these requirements.

6.4 *Thermometer Support*, as shown in Test Method D 88, Fig. 3.

6.5 *Saybolt Viscosity Thermometers*, as listed in Table 1, for reading the temperature of the sample. Each thermometer shall conform to the requirements listed in Specification E 1 for that ASTM Thermometer Number.

6.6 *Bath Thermometers*—Saybolt Viscosity thermometers, or any other temperature-indicating means of equivalent accuracy.

6.7 *Sieve*, 850- μ m (No. 20), conforming to the requirements of Specification E 11.

6.8 *Receiving Flask*, as shown in Test Method D 88, Fig. 5.

6.9 *Timer*, graduated in fifths or tenths of a second, and accurate to within 0.1 % when tested over a 60-min interval. Electric timers are acceptable if operated on a controlled frequency circuit.

6.10 *Hot Plate*, electric, approximately 8 in. (200 mm) in diameter, with a three-heat switch, rated at 1200 W at the high

¹ This test method is under the jurisdiction of ASTM Committee D-8 on Roofing, Waterproofing, and Bituminous Materials and is the direct responsibility of Subcommittee D08.05 on Solvent-Bearing Bituminous Compounds for Roofing and Waterproofing.

Current edition approved Oct. 15, 1993. Published December 1993. Originally published as E 102 – 54 T. Last previous edition E 102 – 81 (1987) ¹.

² *Annual Book of ASTM Standards*, Vol 04.04.

³ *Annual Book of ASTM Standards*, Vol 05.01.

⁴ *Annual Book of ASTM Standards*, Vol 14.03.

⁵ *Annual Book of ASTM Standards*, Vol 14.02.

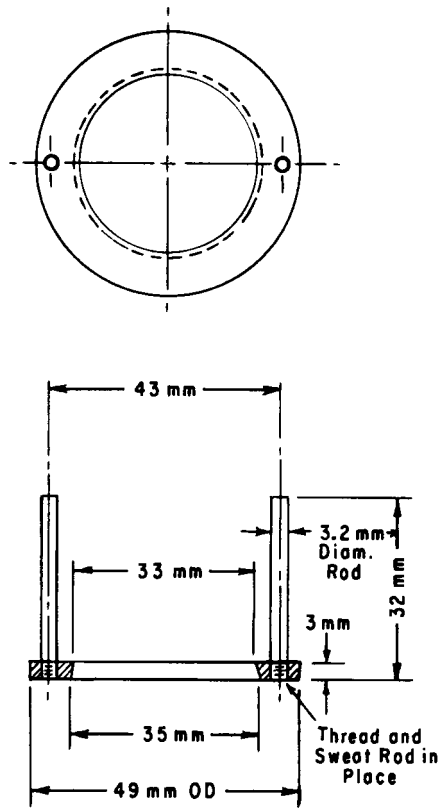

(Material: Corrosion-resistant metal.)

FIG. 1 Displacement Ring

TABLE 1 ASTM Saybolt Viscosity Thermometers

Standard Test Temperature, °F (°C)	ASTM Thermometer Number ^A	Thermometer	
		Range, ° F	Subdivisions, °F
250 (121)	77F	245 to 265	0.5
275 (135)	108F	270 to 290	0.5
300 (149)	78F	295 to 315	0.5
325 (163)	109F	320 to 340	0.5
350 (177)	79F	345 to 365	0.5
400 (204)	80F	395 to 415	0.5
450 (232)	81F	445 to 465	0.5

^AComparable thermometers calibrated in °C are not available.

heat setting and 500 to 600 W at the medium heat setting.

7. Sampling

7.1 Sample the material in accordance with Practice D 140.

8. Preparation of Apparatus

8.1 Clean the viscometer thoroughly with xylene, remove all solvent from the viscometer and its gallery, and dry well. Clean the displacement ring and receiving flask in the same manner. Xylene is a toxic and flammable solvent; all working areas shall be efficiently hooded and kept free of sparks and open flames. If the viscometer is hot, vaporization of xylene can be reduced by filling the tube rapidly and immediately allowing it to flow out through the orifice. A wooden toothpick may be useful in cleaning the orifice.

NOTE 2—The viscometer may be kept clean by filling with cylinder oil immediately after each test and allowing the oil to remain in the

viscometer for several minutes before draining and cleaning with xylene as described above. If desired, the viscometer may be kept filled with cylinder oil between runs, draining and cleaning with xylene just before each test.

8.2 Set up the viscometer and bath in an area where they will not be exposed to drafts or rapid changes in air temperature, and dust or vapors that might contaminate a sample.

8.3 Place the receiving flask beneath the viscometer so that the graduation mark on the flask is from 4 to 5 in. (100 to 130 mm) below the bottom of the viscometer tube, and so that the stream of liquid will just touch the neck of the flask.

8.4 Fill the bath to at least ¼ in. (6 mm) above the overflow rim of the viscometer with an appropriate bath medium for the selected test temperature:

8.4.1 Use SAE 40 grade oil for test temperatures up to 300°F (149°C).

8.4.2 For temperatures above 300°F (149°C), use a cylinder oil having a viscosity of approximately 175 to 185 SUS at 210°F (98.9°C), and a minimum flash point of 572°F (300°C) when tested in accordance with Test Method D 92.

8.4.3 Change the bath medium periodically, and clean the outside walls of the tubes to remove any carbon deposits.

8.5 Provide adequate stirring and thermal control for the bath so that the temperature of a test sample in the viscometer will not vary more than 0.5°F (0.3°C) after reaching the selected test temperature.

9. Calibration and Standardization

9.1 Calibrate the Saybolt Furol viscometer at periodic intervals in accordance with Test Method D 88, Section 9, and calculate the correction factor for the viscometer.

9.2 Do not use viscometers or orifices requiring corrections greater than ±1 %.

10. Procedure

10.1 Establish and control the bath temperature at the selected test temperature.

10.1.1 Standard test temperatures for measuring Saybolt Furol viscosities of bituminous materials are 250, 275, 300, 325, 350, 400, and 450°F (121, 135, 149, 163, 177, 204, and 232°C).

10.2 Insert a cork stopper, having a cord attached for its easy removal, into the air chamber at the bottom of the viscometer. The cork shall fit tightly enough to prevent the escape of air, as evidenced by the absence of oil on the cork when it is withdrawn later as described.

10.3 Place the displacement ring in the gallery of the viscometer.

10.4 Preheat a 1-lb (0.5-kg) sample in a 16-oz (500-mL) seamless tin box of the deep type on the electric hot plate to about 18 to 27°F (10 to 15°C) above the selected test temperature.

10.4.1 Use the medium-temperature setting on the hot plate for the first half hour, and the high-temperature setting for the remainder of the heating period. Avoid overheating initially because this might cause some oxidation of the sample and alter its viscosity.

10.4.2 Stir the sample occasionally during the early stages

of heating, but employ continuous stirring for the last 50°F (28°C).

10.4.3 Complete the preheating in 2 h or less, and proceed immediately with the viscosity determination. Reheating of any sample shall not be permitted.

10.5 Preheat the 850- μm (No. 20) sieve to the selected test temperature, and pour the heated sample through the sieve directly into the viscometer until the level is just above the overflow rim.

NOTE 3—Just enough sample should overflow so that later removal of the displacement ring will cause the excess to flow into the gallery without completely filling it.

10.6 Place the cover on the viscometer over the displacement ring, and insert the appropriate viscosity thermometer equipped with the thermometer support through the hole in the center of the cover.

10.7 Stir the sample in the viscometer continuously with the thermometer, using a circular motion at 30 to 50 rpm in a *horizontal* plane to avoid whipping air into the sample. Take care to avoid striking the orifice.

10.8 When the sample temperature remains constant within 0.5°F (0.3°C) of the test temperature during 1 min of continuous stirring, withdraw the thermometer and remove the cover from the viscometer. Immediately remove the displacement ring, check to be sure that the excess sample in the gallery is below the level of the overflow rim, and replace the cover on the viscometer.

10.9 Check to be sure that the receiving flask is in proper position; then snap the cork from the viscometer using the attached cord, and start the timer at the same instant. The elapsed time from filling the viscometer to snapping the cork shall not exceed 15 min.

10.10 Stop the timer the instant the sample reaches the graduation mark on the receiving flask. Record the efflux time in seconds to the nearest 0.1 or 0.2 s.

11. Calculation and Report

11.1 Multiply the efflux time by the correction factor for the viscometer determined in 9.1.

11.2 Report the corrected efflux time as the Saybolt Furol viscosity of the material at the temperature at which the test was made.

11.2.1 Report values below 200 s to the nearest 0.5 s. Report values of 200 s or higher to the nearest whole second.

12. Precision and Bias

12.1 Results should not differ from the mean by more than the following:

12.1.1 *Repeatability* (one operator and apparatus)—1 %.

12.1.2 *Reproducibility* (different operators and apparatus)—2 %.

13. Keywords

13.1 bituminous; high temperature; Saybolt Furol; viscosity

The American Society for Testing and Materials takes no position respecting the validity of any patent rights asserted in connection with any item mentioned in this standard. Users of this standard are expressly advised that determination of the validity of any such patent rights, and the risk of infringement of such rights, are entirely their own responsibility.

This standard is subject to revision at any time by the responsible technical committee and must be reviewed every five years and if not revised, either reapproved or withdrawn. Your comments are invited either for revision of this standard or for additional standards and should be addressed to ASTM Headquarters. Your comments will receive careful consideration at a meeting of the responsible technical committee, which you may attend. If you feel that your comments have not received a fair hearing you should make your views known to the ASTM Committee on Standards, 100 Barr Harbor Drive, West Conshohocken, PA 19428.

This standard is copyrighted by ASTM, 100 Barr Harbor Drive, West Conshohocken, PA 19428-2959, United States. Individual reprints (single or multiple copies) of this standard may be obtained by contacting ASTM at the above address or at 610-832-9585 (phone), 610-832-9555 (fax), or service@astm.org (e-mail); or through the ASTM website (<http://www.astm.org>).