



Standard Test Method for Pour Point of Petroleum Products¹

This standard is issued under the fixed designation D 97; the number immediately following the designation indicates the year of original adoption or, in the case of revision, the year of last revision. A number in parentheses indicates the year of last reapproval. A superscript epsilon (ϵ) indicates an editorial change since the last revision or reapproval.

This test method has been adopted for use by government agencies to replace Method 201 of Federal Test Methods Standard No. 791b, and Method 4452 of Federal Test Method Standard No. 141A.

This test method was adopted as a joint ASTM-IP Standard in 1965.

1. Scope

1.1 This test method is intended for use on any petroleum product.² A procedure suitable for black specimens, cylinder stock, and nondistillate fuel oil is described in 8.8. A procedure for testing the fluidity of a residual fuel oil at a specified temperature is described in the appendix.

1.2 *This standard does not purport to address all of the safety concerns, if any, associated with its use. It is the responsibility of the user of this standard to establish appropriate safety and health practices and determine the applicability of regulatory limitations prior to use.* For specific hazard statements, see Section 7.

2. Referenced Documents

2.1 ASTM Standards:

- D 117 Guide for Sampling, Test Methods, Specifications, and Guide for Electrical Insulating Oils of Petroleum Origin³
- D 396 Specification for Fuel Oils⁴
- D 1659 Test Method for Maximum Fluidity Temperature of Residual Fuel Oil⁵
- D 2500 Test Method for Cloud Point of Petroleum Oils⁴
- D 3245 Test Method for Pumpability of Industrial Fuel Oils⁶

E 1 Specification for ASTM Thermometers⁷

E 77 Test Method for Inspection and Verification of Thermometers⁷

2.2 IP Standards:

Specifications for IP Standard Thermometers⁸

3. Terminology

3.1 Definitions:

3.1.1 *black oil, n*—lubricant containing asphaltic materials. Black oils are used in heavy-duty equipment applications, such as mining and quarrying, where extra adhesiveness is desired.

3.1.2 *cylinder stock, n*—lubricant for independently lubricated engine cylinders, such as those of steam engines and air compressors. Cylinder stock are also used for lubrication of valves and other elements in the cylinder area.

3.1.3 *pour point, n—in petroleum products*, the lowest temperature at which movement of the test specimen is observed under prescribed conditions of test.

3.1.4 *residual fuel, n*—a liquid fuel containing bottoms remaining from crude distillation or thermal cracking; sometimes referred to as heavy fuel oil.

3.1.4.1 *Discussion*—Residual fuels comprise Grades 4, 5, and 6 fuel oils, as defined in Specification D 396.

4. Summary of Test Method

4.1 After preliminary heating, the sample is cooled at a specified rate and examined at intervals of 3°C for flow characteristics. The lowest temperature at which movement of the specimen is observed is recorded as the pour point.

5. Significance and Use

5.1 The pour point of a petroleum specimen is an index of the lowest temperature of its utility for certain applications.

¹ This test method is under the jurisdiction of ASTM Committee D02 on Petroleum Products and Lubricants and is the direct responsibility of Subcommittee D02.07 on Flow Properties.

Current edition approved March 10, 2002. Published May 2002. Originally published as D 97 – 27. In 1927, revised and replaced former D 47. Last previous edition D 97 – 96a.

In the IP, this test method is under the jurisdiction of the Standardization Committee.

² Statements defining this test and its significance when applied to electrical insulating oils of mineral origin will be found in Guide D 117.

³ *Annual Book of ASTM Standards*, Vol 10.03.

⁴ *Annual Book of ASTM Standards*, Vol 05.01.

⁵ Discontinued; see 1984 *Annual Book of ASTM Standards*, Vol 05.01.

⁶ *Annual Book of ASTM Standards*, Vol 05.02

⁷ *Annual Book of ASTM Standards*, Vol 14.03.

⁸ *Methods for Analysis and Testing, IP Standards for Petroleum and its Products, Part I, Vol 2.*

6. Apparatus

6.1 *Test Jar*, cylindrical, of clear glass, flat bottom, 33.2 to 34.8-mm outside diameter, and 115 to 125 mm in height. The inside diameter of the jar can range from 30.0 to 32.4 mm, within the constraint that the wall thickness be no greater than 1.6 mm. The jar shall have a line to indicate a sample height 54 ± 3 mm above the inside bottom. See Fig. 1.

6.2 *Thermometers*, having the following ranges and conforming to the requirements prescribed in Specification E 1 for thermometers:

Thermometer	Temperature Range	Thermometer Number	
		ASTM	IP
High cloud and pour	-38 to + 50°C	5C	1C
Low cloud and pour	-80 to + 20°C	6C	2C
Melting point	+ 32 to + 127°C	61C	63C

6.2.1 Since separation of liquid column thermometers occasionally occurs and may escape detection, thermometers should be checked immediately prior to the test and used only if they prove accurate within ± 1°C (for example ice point).

6.3 *Cork*, to fit the test jar, bored centrally for the test thermometer.

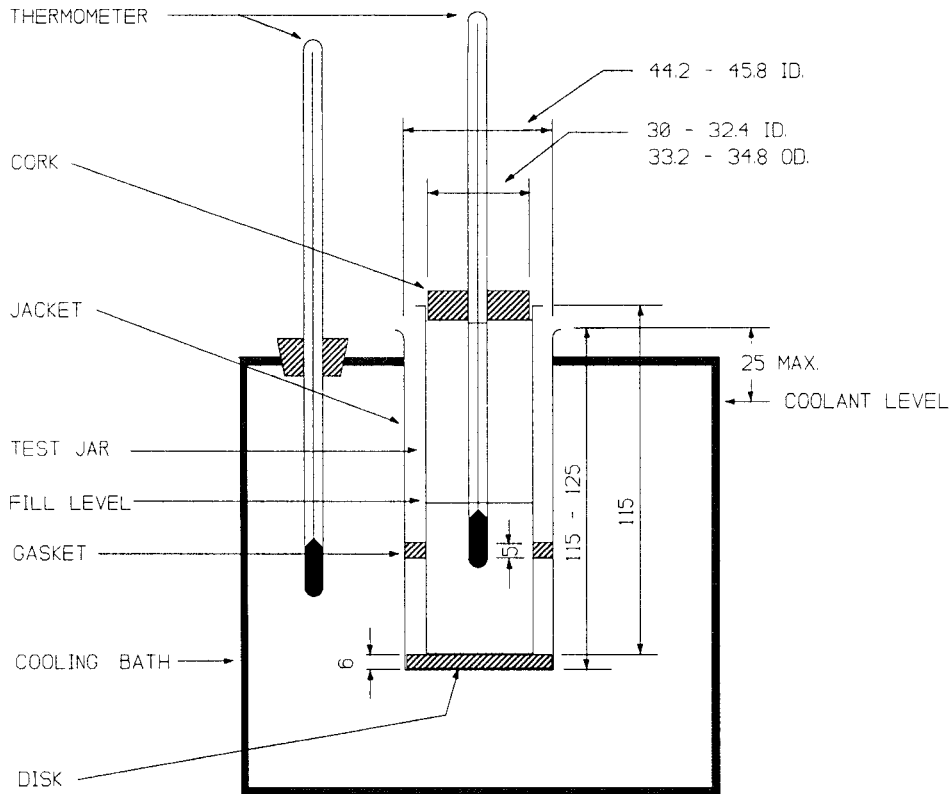

NOTE 1—Dimensions are in millimetres (not to scale).

FIG. 1 Apparatus for Pour Point Test

6.4 *Jacket*, watertight, cylindrical, metal, flat-bottomed, 115 ± 3-mm depth, with inside diameter of 44.2 to 45.8 mm. It shall be supported in a vertical position in the cooling bath (see 6.7) so that not more than 25 mm projects out of the cooling medium, and shall be capable of being cleaned.

6.5 *Disk*, cork or felt, 6 mm thick to fit loosely inside the jacket.

6.6 *Gasket*, to fit snugly around the outside of the test jar and loosely inside the jacket. The gasket may be made of rubber, leather, or other material that is elastic enough to cling to the test jar and hard enough to hold its shape. Its purpose is to prevent the test jar from touching the jacket.

6.7 *Bath or Baths*, maintained at prescribed temperatures with a firm support to hold the jacket vertical. The required bath temperatures may be obtained by refrigeration if available, otherwise by suitable freezing mixtures. Freezing mixtures commonly used for temperatures down to those shown are as follows:

	For Temperatures Down
Ice and water	9°C
Crushed ice and sodium chloride crystals	-12°C
Crushed ice and calcium chloride crystals	-27°C
Acetone or petroleum naphtha (see Section 6) chilled in a covered metal beaker with an ice-salt mixture to - 12°C then with enough solid carbon dioxide to give the desired temperature.	-57°C

NOTE 1—There are automatic pour point testers available and in use which may be advantageous in the saving of test time, permit the use of smaller samples, and have other factors which may merit their use. If automatic testers are used, the user must ensure that all of the manufacturer's instructions for calibration, adjustment, and operation of the instrument are followed. It must be reported that the pour point was determined by an automatic instrument. In any case of dispute, the pour point as determined by the manual method described herein shall be considered the reference test.

7. Reagents and Materials

7.1 The following solvents of technical grade are appropriate for low-temperature bath media.

7.1.1 *Acetone*, (**Warning**—Extremely flammable).

7.1.2 *Alcohol, Ethanol* (**Warning**—Flammable).

7.1.3 *Alcohol, Methanol* (**Warning**—Flammable. Vapor harmful).

7.1.4 *Petroleum Naphtha*, (**Warning**—Combustible. Vapor harmful).

7.1.5 *Solid Carbon Dioxide*, (**Warning**—Extremely cold - 78.5°C).

8. Procedure

8.1 Pour the specimen into the test jar to the level mark. When necessary, heat the specimen in a water bath until it is just sufficiently fluid to pour into the test jar.

NOTE 2—It is known that some materials, when heated to a temperature higher than 45°C during the preceding 24 h, do not yield the same pour point results as when they are kept at room temperature for 24 h prior to testing. Examples of materials which are known to show sensitivity to thermal history are residual fuels, black oils, and cylinder stocks.

8.1.1 Samples of residual fuels, black oils, and cylinder stocks which have been heated to a temperature higher than 45°C during the preceding 24 h, or when the thermal history of

these sample types is not known, shall be kept at room temperature for 24 h before testing. Samples which are known by the operator not to be sensitive to thermal history need not be kept at room temperature for 24 h before testing.

8.1.2 Experimental evidence supporting elimination of the 24-h waiting period for some sample types is contained in a research report.⁹

8.2 Close the test jar with the cork carrying the high-pour thermometer (5.2). In the case of pour points above 36°C, use a higher range thermometer such as IP 3C or ASTM 61C. Adjust the position of the cork and thermometer so the cork fits tightly, the thermometer and the jar are coaxial, and the thermometer bulb is immersed so the beginning of the capillary is 3 mm below the surface of the specimen.

8.3 For the measurement of pour point, subject the specimen in the test jar to the following preliminary treatment:

8.3.1 *Specimens Having Pour Points Above - 33°C*—Heat the specimen without stirring to 9°C above the expected pour point, but to at least 45°C, in a bath maintained at 12°C above the expected pour point, but at least 48°C. Transfer the test jar to a water bath maintained at 24°C and commence observations for pour point.

8.3.2 *Specimens Having Pour Points of - 33°C and Below*—Heat the specimen without stirring to 45°C in a bath maintained at 48°C and cool to 15°C in a water bath maintained at 6°C. Remove the high cloud and pour thermometer, and place the low cloud and pour thermometer in position.

8.4 See that the disk, gasket, and the inside of the jacket are clean and dry. Place the disk in the bottom of the jacket. Place the gasket around the test jar, 25 mm from the bottom. Insert the test jar in the jacket. Never place a jar directly into the cooling medium.

8.5 After the specimen has cooled to allow the formation of paraffin wax crystals, take great care not to disturb the mass of specimen nor permit the thermometer to shift in the specimen; any disturbance of the spongy network of wax crystals will lead to low and erroneous results.

8.6 Pour points are expressed in integers that are positive or negative multiples of 3°C. Begin to examine the appearance of the specimen when the temperature of the specimen is 9°C above the expected pour point (estimated as a multiple of 3°C). At each test thermometer reading that is a multiple of 3°C below the starting temperature remove the test jar from the jacket. To remove condensed moisture that limits visibility wipe the surface with a clean cloth moistened in alcohol (ethanol or methanol). Tilt the jar just enough to ascertain whether there is a movement of the specimen in the test jar. The complete operation of removal, wiping, and replacement shall require not more than 3 s.

8.6.1 If the specimen has not ceased to flow when its temperature has reached 27°C, transfer the test jar to the next lower temperature bath in accordance with the following schedule:

Specimen is at + 27°C, move to 0°C bath,
Specimen is at + 9°C, move to - 18°C bath,
Specimen is at - 6°C, move to - 33°C bath,

⁹ Available from ASTM International Headquarters. Request RR:D02-1377.

Specimen is at -24°C , move to -51°C bath,
 Specimen is at -42°C , move to -69°C bath. (1)

8.6.2 As soon as the specimen in the jar does not flow when tilted, hold the jar in a horizontal position for 5 s, as noted by an accurate timing device and observe carefully. If the specimen shows any movement, replace the test jar immediately in the jacket and repeat a test for flow at the next temperature, 3°C lower.

8.7 Continue in this manner until a point is reached at which the specimen shows no movement when the test jar is held in a horizontal position for 5 s. Record the observed reading of the test thermometer.

8.8 For black specimen, cylinder stock, and nondistillate fuel specimen, the result obtained by the procedure described in 8.1 through 8.7 is the upper (maximum) pour point. If required, determine the lower (minimum) pour point by heating the sample while stirring, to 105°C , pouring it into the jar, and determining the pour point as described in 8.4 through 8.7.

8.9 Some specifications allow for a pass/fail test or have pour point limits at temperatures not divisible by 3°C . In these cases, it is acceptable practice to conduct the pour point measurement according to the following schedule: Begin to examine the appearance of the specimen when the temperature of the specimen is 9°C above the specification pour point. Continue observations at 3°C intervals as described in 8.6 and 8.7 until the specification temperature is reached. Report the sample as passing or failing the specification limit.

9. Calculation and Report

9.1 Add 3°C to the temperature recorded in 8.7 and report the result as the Pour Point, ASTM D 97. For black oil, and so forth, add 3°C to the temperature recorded in 8.7 and report the result as Upper Pour Point, ASTM D 97, or Lower Pour Point, ASTM D 97, as required.

10. Precision and Bias

10.1 Lubricating Oil and Distillate and Residual Fuel Oil.¹⁰

10.1.1 *Repeatability*—The difference between successive test results, obtained by the same operator using the same apparatus under constant operating conditions on identical test material, would in the long run, in the normal and correct operation of this test method, exceed 3°C only in one case in twenty. Differences greater than this should be considered suspect.

10.1.2 *Reproducibility*—The difference between two single and independent test results, obtained by different operators working in different laboratories on identical test material, would in the long run, in the normal and correct operation of this test method, exceed 6°C only in one case in twenty. Differences greater than this should be considered suspect.

10.2 *Bias*—There being no criteria for measuring bias in these test-product combinations, no statement of bias can be made.

10.3 The precision statements were prepared with data on ten new (unused) mineral oil-based lubricants and sixteen assorted fuel oils tested by twelve cooperators. The mineral oil-based lubricants had pour points ranging from -48 to -6°C while the fuel oils had pour points ranging from -33 to $+51^{\circ}\text{C}$. The following precision data were obtained:

	Mineral Oil Lubricants	Fuel Oils
95 % Confidence		
Repeatability, $^{\circ}\text{C}$	2.87	2.52
Reproducibility, $^{\circ}\text{C}$	6.43	6.59

¹⁰ The cloud point procedure formerly part of this test method now appears as Test Method D 2500.

APPENDIX

(Nonmandatory Information)

X1. TEST FOR FLUIDITY OF A RESIDUAL FUEL OIL AT A SPECIFIED TEMPERATURE

X1.1 General

X1.1.1 The low-temperature flow properties of a waxy fuel oil depend on handling and storage conditions. Thus, they may not be truly indicated by pour point. The pour point test does not indicate what happens when an oil has a considerable head of pressure behind it, such as when gravitating from a storage tank or being pumped along a pipeline. Failure to flow at the pour point is normally attributed to the separation of wax from the fuel; however, it can also be due to the effect of viscosity in the case of very viscous fuel oils. In addition pour points of residual fuels are influenced by the previous thermal history of the specimens. A loosely knit wax structure built up on cooling of the oil can be normally broken by the application of relatively little pressure.

X1.1.2 The usefulness of the pour point test in relation to residual fuel oils is open to question, and the tendency to

regard the pour point as the limiting temperature at which a fuel will flow can be misleading. The problem of accurately specifying the handling behavior of fuel oil is important, and because of the technical limitations of the pour point test, various pumpability tests have been devised to assess the low-temperature flow characteristics of heavy residual fuel oils. Test Method D 3245 is one such method. However, most alternative methods tend to be time-consuming and as such do not find ready acceptance as routine control tests for determining low-temperature flow properties. One method which is relatively quick and easy to perform and has found limited acceptance as a “go-no-go” method is based on the appendix method to the former Test Method D 1659 – 65. The method is described as follows.

X1.2 Scope

X1.2.1 This method covers the determination of the fluidity of a residual fuel oil at a specified temperature in an as-received condition.

X1.3 Definition

X1.3.1 *fluidity temperature*—the sample when tested in an as-received condition is considered “fluid at the temperature of the test” if it will flow 2 mm in 1 min in a 12.5 mm U-tube under a maximum pressure of 152 mm of mercury.

X1.4 Summary of Test Method

X1.4.1 A sample of fuel in its as-received condition is cooled at the specified temperature for 30 min in the standard U-tube and is tested for movement under prescribed pressure conditions.

X1.5 Significance and Use

X1.5.1 This method may be used as a “go-no-go” procedure for operational situations where it is necessary to ascertain the fluidity of a residual oil under prescribed conditions in an as-received condition. The conditions of this method simulate those of a pumping situation where the oil is expected to flow through a 12-mm pipe under slight pressure at a specified temperature. Fluidity, like Test Method D 97, is used to define cold flow properties. It differs from D 97, however, in that (a) it is restricted to residual fuel oil and (b) a prescribed pressure is applied to the sample. The latter represents an attempt to overcome the technical limitations of the Pour Point Method where gravity-induced flow is the criterion. Test Method D 3245, represents another method for predicting field performance in cold flow conditions. Test Method D 3245, however, does have limitations and may not be suitable for use with very waxy fuel oils which solidify so rapidly in the chilling bath that a reading cannot be obtained under the conditions of the test. It is also a time-consuming test and therefore not suitable for routine control testing.

X1.6 Apparatus

X1.6.1 *Glass U-Tubes*, 150 mm high, having a uniform internal diameter of 12.5 ± 1 mm and a radius of curvature, measured to the outside curve of the tube of 35 mm (Fig. X1.1).

X1.6.2 *Thermometers*—Thermometers having a range from -38 to $+50^\circ\text{C}$ and conforming to the requirements of Thermometer 5C as prescribed in Specification E 1, shall be used for insertion in the glass U-tubes and for measuring the temperatures of the baths.

X1.6.3 *Fluidity Temperature Test Bath*,¹¹

consists of a reservoir, a stirrer, and a motor and pump to circulate coolant through the coils of the tubing placed in the bottom of the test bath and passing through the cold bath. The flow of coolant through these coils can be controlled by a thermostat and a solenoid valve. It is possible that, where justified by the quantity of work, more than one such bath

could be utilized to permit concurrent testing at more than one temperature (Fig. X1.2).

X1.6.4 *Mercury Manometer* calibrated in 10-mm divisions with a distinguishing mark at 152 mm (equivalent to 20.3 kPa).

X1.6.5 *Automatic Vacuum Controller*¹² (as shown in Fig. X1.3 and Fig. X1.4) — A device that gradually increased the vacuum applied to one end of the U-tube at the specified rate of 10 mm/4S.

X1.7 Preparation of Apparatus

X1.7.1 Adjust the automatic vacuum controller as follows: close the stopcock on the tube connecting the automatic vacuum controller to the fluidity tester. A pinchcock on the rubber tube will serve as well as a stopcock. Wind the thread attached to the steel rod around the pulley on the synchronous motor until the end of the rod is about 15 mm above the zero level of the mercury in the control manometer. Turn on the power switch. The thread will begin to unwind, lowering the steel rod. When the rod contacts the mercury, the relay will open the solenoid valve in the vacuum line and air will be pumped from the system at a rate limited by the needle valve. Adjust this needle valve until the descending mercury in the control manometer just leads the rod, reducing the relay operation to a minimum. When properly adjusted, the pulsations caused by the opening and closing of the solenoid valve should not exceed ± 1 mm. In this manner the pressure in the system will be reduced gradually at a rate governed by the descent of the steel rod.

X1.8 Procedure

X1.8.1 Pour the sample as received into a thoroughly cleaned and dry standard fluidity U-tube, without contacting the upper walls of the tube, until the vertical height of the sample in the U-tube is 38 mm. Insert in one leg of each U-tube an ASTM Thermometer 5C in a cork that has been grooved to permit the passage of air. The thermometer must be placed in the center of the tube and its bulb immersed so that the beginning of the capillary is 3 mm below the surface of the specimen.

X1.8.2 Fix the tube in the bath set at the specific temperature, immersed to a depth of approximately 75 mm. Control the bath and sample temperatures within $\pm 1^\circ\text{C}$ and $\pm 0.5^\circ\text{C}$, respectively, of the specified temperature of the test.

X1.8.3 Maintain the sample at the specified temperature for $30 \text{ min} \pm 30 \text{ s}$, with the U-tube connected to the automatic vacuum controller, and the stopcock or pinch-clamp open. Wind the thread on the pulley attached to the synchronous motor. Turn the power switch to the ON position. Apply suction automatically to the U-tube at the prescribed rate. Observe any movement of the specimen during a one-minute interval which is the time required to apply 152-mm Hg vacuum to the specimen in the U-tube. Immediately disconnect the U-tube from the automatic vacuum controller, turn off the power switch and rewind the thread. If the specimen has moved 2 mm or more during the time (1 min) the suction was

¹¹ A kinematic viscosity bath is usually satisfactory.

¹² This apparatus may be shop fabricated. Details of special parts are indicated in Figs. X1.3 and X1.4. Alternatively the apparatus can be purchased.

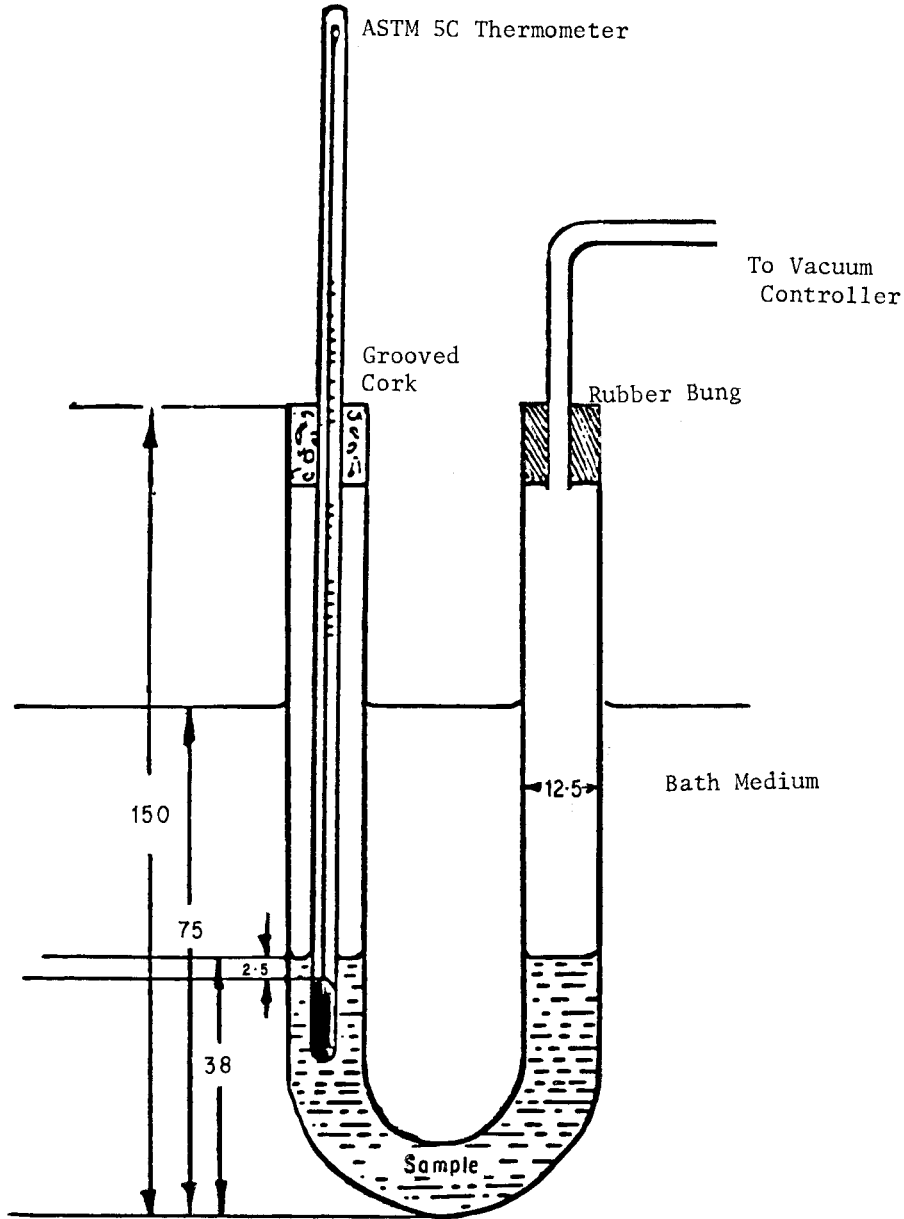

NOTE 1—All dimensions are in millimetres

FIG. X1.1 Disposition of U-tube in Fluidity Temperature Test Bath

applied, the specimen is considered fluid at the temperature of the test.

X1.9 Report

X1.9.1 Report the fluidity of the sample at a specified temperature as follows:

X1.9.1.1 If the sample fulfills the conditions of flow, as defined in X1.3.1, report fluidity: “Fluid at (temperature of test)” or fluidity at (temperature of test): “Pass.”

X1.9.1.2 If the sample does not fulfill the conditions of flow,

as defined in X1.3.1, report fluidity: “Not fluid at (temperature of test)” or fluidity at (temperature of test): “Fail.”

X1.10 Precision and Bias

X1.10.1 As in the case of pass-fail data, no statement is made about either the precision or the bias of this method for measuring the fluidity of a residual fuel specimen since the result merely states whether there is conformance to the criteria for success specified in the procedure.

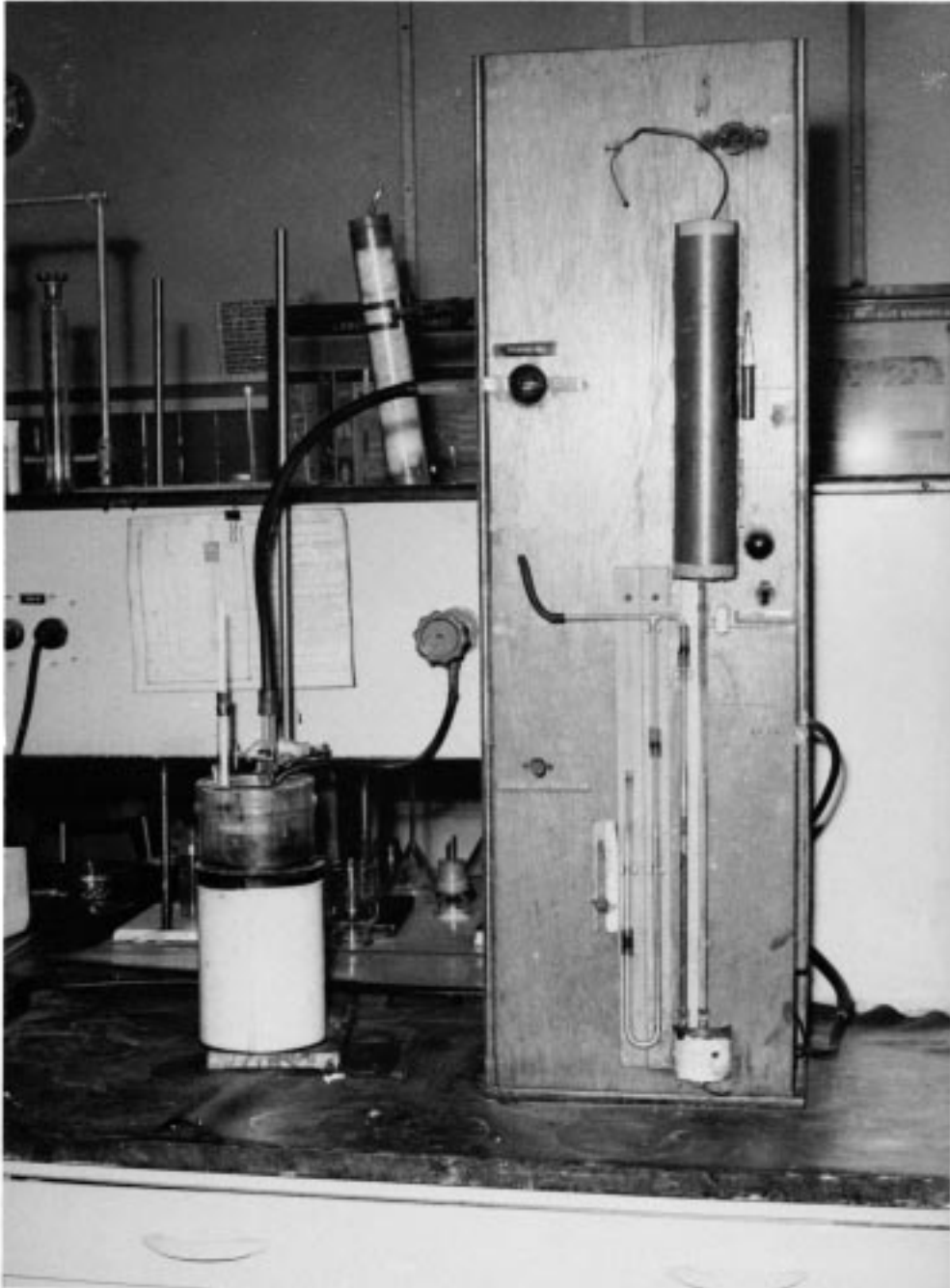
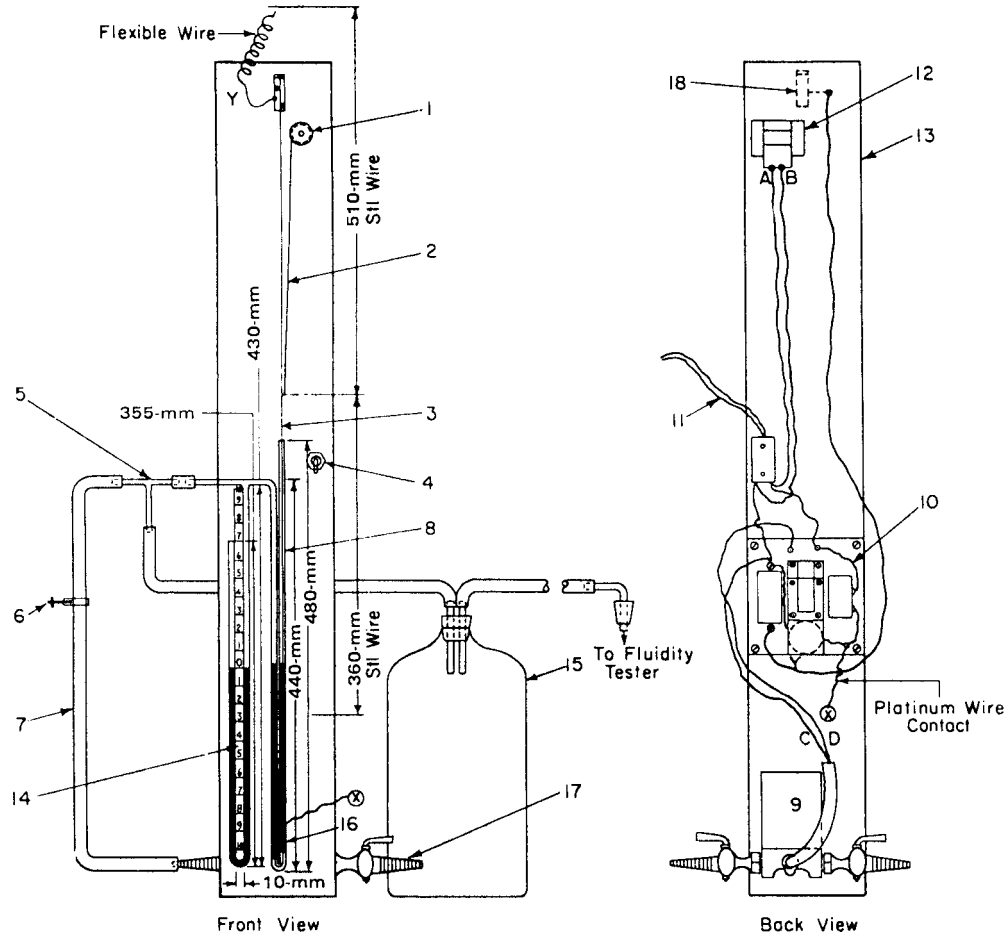
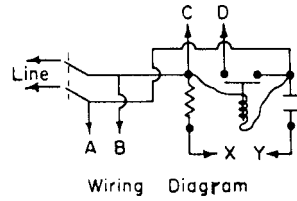

FIG. X1.2 Fluidity Temperature Apparatus

TABLE X1.3



- 1—26mm diam. face pulley.
- 2—Thread
- 3—Steel rod.
- 4—Switch-DPST.
- 5—Tee 90mm long.
- 6—Needle valve.
- 7—Rubber or plastic tubing.
- 8—6mm heat resistant glass tube.
- 9—Solenoid valve.
- 10—Electric relay.

- 11—Electric cord to outlet
- 12—Synchronous motor.
- 13—Plywood of approximately 10mm thickness
- 14—Millimeter scale.
- 15—4 liter bottle
- 16—0.5 mm heat resistant glass capillary.
- 17—To vacuum line.
- 18—Rod holder.

FIG. X1.3 Assembly Automatic Vacuum Controller Apparatus

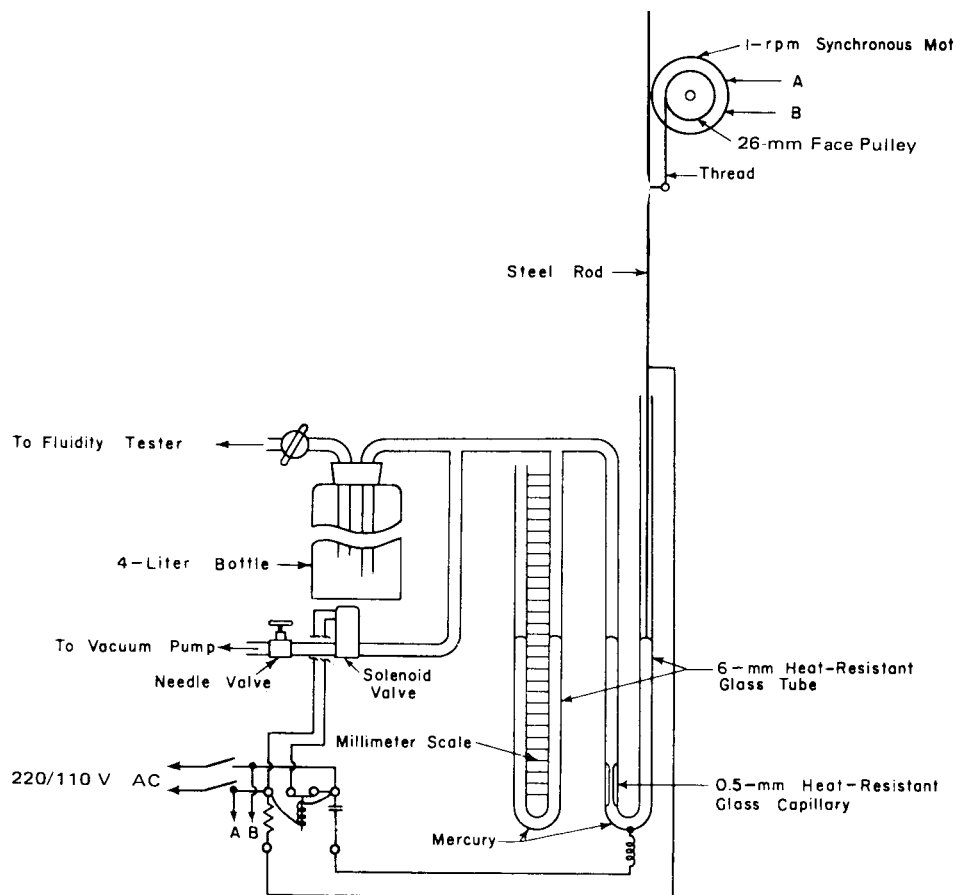

FIG. X1.4 Detail of Automatic Vacuum Controller

ASTM International takes no position respecting the validity of any patent rights asserted in connection with any item mentioned in this standard. Users of this standard are expressly advised that determination of the validity of any such patent rights, and the risk of infringement of such rights, are entirely their own responsibility.

This standard is subject to revision at any time by the responsible technical committee and must be reviewed every five years and if not revised, either reapproved or withdrawn. Your comments are invited either for revision of this standard or for additional standards and should be addressed to ASTM International Headquarters. Your comments will receive careful consideration at a meeting of the responsible technical committee, which you may attend. If you feel that your comments have not received a fair hearing you should make your views known to the ASTM Committee on Standards, at the address shown below.

This standard is copyrighted by ASTM International, 100 Barr Harbor Drive, PO Box C700, West Conshohocken, PA 19428-2959, United States. Individual reprints (single or multiple copies) of this standard may be obtained by contacting ASTM at the above address or at 610-832-9585 (phone), 610-832-9555 (fax), or service@astm.org (e-mail); or through the ASTM website (www.astm.org).