



Standard Test Method for Oxidation Characteristics of Inhibited Mineral Oils¹

This standard is issued under the fixed designation D 943; the number immediately following the designation indicates the year of original adoption or, in the case of revision, the year of last revision. A number in parentheses indicates the year of last reapproval. A superscript epsilon (ϵ) indicates an editorial change since the last revision or reapproval.

This standard has been approved for use by agencies of the Department of Defense.

1. Scope

1.1 This test method is used to evaluate the oxidation stability of inhibited steam-turbine oils in the presence of oxygen, water, and copper and iron metals at an elevated temperature. The test method is also used for testing other oils such as hydraulic oils and circulating oils having a specific gravity less than that of water and containing rust and oxidation inhibitors.

1.2 The values stated in SI units are to be regarded as the standard. The values given in parentheses are for information only.

1.3 *This standard does not purport to address all of the safety concerns, if any, associated with its use. It is the responsibility of the user of this standard to establish appropriate safety and health practices and determine the applicability of regulatory limitations prior to use.* For specific precautionary statements, see Section 6.

2. Referenced Documents

2.1 ASTM Standards:

- A 510 Specification for General Requirements for Wire Rods and Coarse Round Wire, Carbon Steel²
- B 1 Specification for Hard-Drawn Copper Wire³
- D 664 Test Method for Acid Number of Petroleum Products by Potentiometric Titration⁴
- D 1193 Specification for Reagent Water⁵
- D 3244 Practice for Utilization of Test Data to Determine Conformance with Specifications⁶
- D 3339 Test Method for Acid Number of Petroleum Products by Semi-Micro Color Indicator Titration⁶
- D 4057 Practice for Manual Sampling of Petroleum and Petroleum Products⁶
- D 4310 Test Method for Determination of the Sludging and

Corrosion Tendencies of Inhibited Mineral Oils⁶

D 5770 Test Method for Semi-Quantitative Micro Determination of Acid Number of Used Lubricating Oils⁷

E 1 Specification for ASTM Thermometers⁸

2.2 IP Standards:⁹

Specifications for IP Standard Thermometers

2.3 British Standard:¹⁰

BS 1829

3. Summary of Test Method

3.1 The oil sample is contacted with oxygen in the presence of water and an iron-copper catalyst at 95°C. The test continues until the measured acid number of the oil is 2.0 mg KOH/g or above. The number of test hours required for the oil to reach 2.0 mg KOH/g is the “oxidation lifetime.”

4. Significance and Use

4.1 This test method is widely used for specification purposes and is considered of value in estimating the oxidation stability of lubricants, especially those that are prone to water contamination. It should be recognized, however, that correlation between results of this method and the oxidation stability of a lubricant in field service may vary markedly with field service conditions and with various lubricants. The precision statement for this method was determined on steam turbine oils.

NOTE 1—Furthermore, in the course of testing a lubricant by this method, other signs of deterioration, such as sludge formation or catalyst coil corrosion, may appear that are not reflected in the calculated oxidation lifetime. The subcommittee responsible for this method is investigating the application of alternative criteria for evaluation of lubricants using this test apparatus. Test Method D 4310 is now available for sludge measurement.

5. Apparatus

5.1 *Oxidation Cell*, of borosilicate glass, as shown in Fig. 1, consisting of a test tube, condenser, and oxygen delivery tube. The test tube has a calibration line at 300 mL (maximum error

¹ This test method is under the jurisdiction of ASTM Committee D02 on Petroleum Products and Lubricants and is the direct responsibility of Subcommittee D02.09 on Oxidation.

Current edition approved August 10, 2002. Published October 2002. Originally published as D 943–47. Last previous edition D 943–99.

In 1976, this test method ceased to be a joint ASTM-IP standard.

² *Annual Book of ASTM Standards*, Vol 01.03.

³ *Annual Book of ASTM Standards*, Vol 02.03.

⁴ *Annual Book of ASTM Standards*, Vol 05.01.

⁵ *Annual Book of ASTM Standards*, Vol 11.01.

⁶ *Annual Book of ASTM Standards*, Vol 05.02.

⁷ *Annual Book of ASTM Standards*, Vol 05.03.

⁸ *Annual Book of ASTM Standards*, Vol 14.03.

⁹ Available from the Institute of Petroleum, 61 New Cavendish St., London, W1G 7AR, United Kingdom.

¹⁰ Available from British Standards Institute, 389 Chiswick High Rd., London, W4 4AL, United Kingdom.

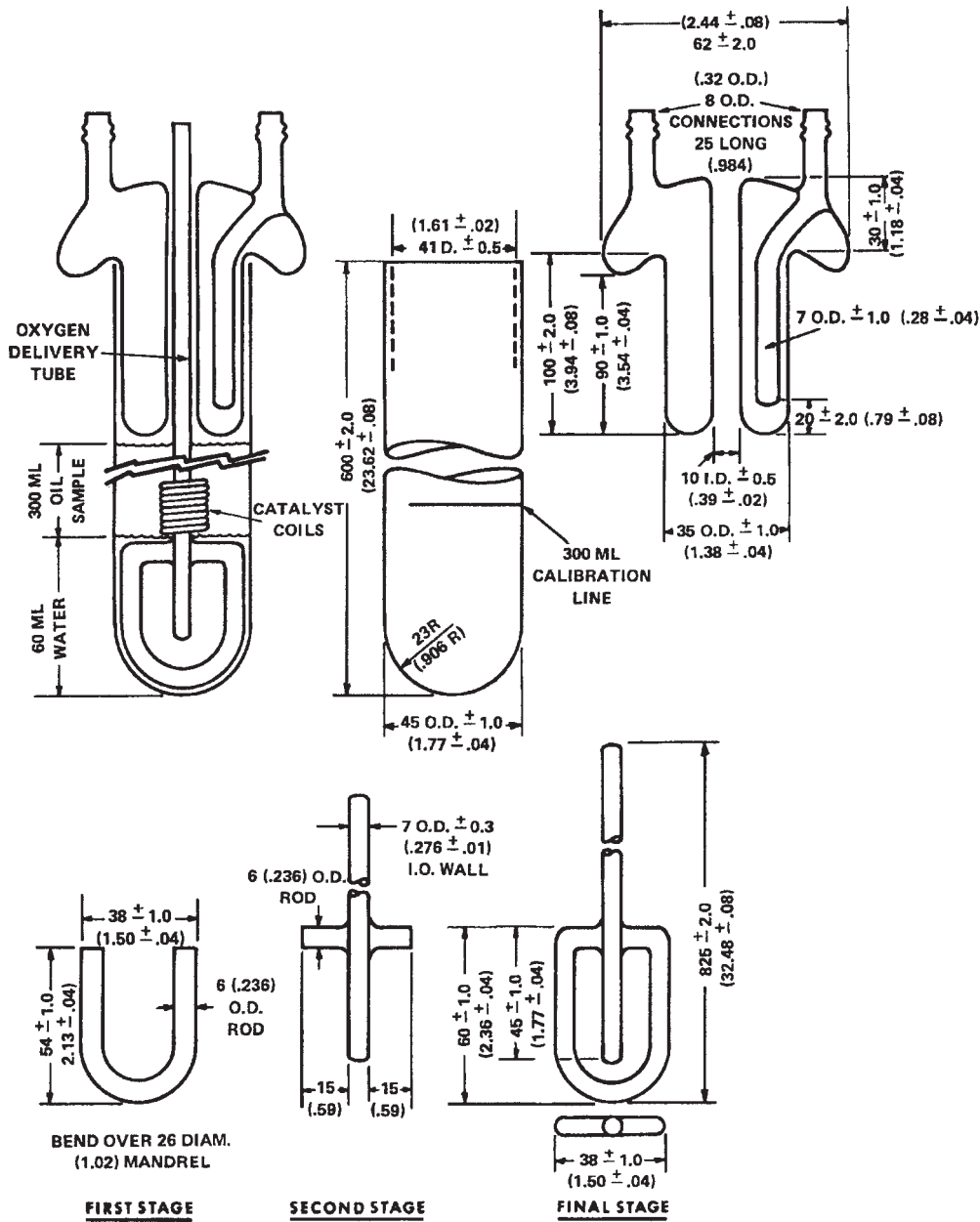

All dimensions are in millimetres (inches)

- Notes:
1. The oxidation test tube has a calibration line at 300 mL. This calibration applies to the test tube alone at 20°C.
 2. Open tube ends to be ground and fire-polished.

FIG. 1 Oxidation Cell

1 mL). This calibration applies to the test tube alone at 20°C.

5.2 Heating Bath, thermostatically controlled, capable of maintaining the oil sample in the oxidation cell at a temperature of 95 ± 0.2°C, fitted with a suitable stirring device to provide a uniform temperature throughout the bath, and large enough to hold the desired number of oxidation cells immersed in the heating bath to a depth of 390 ± 10 mm and in the heating liquid itself to a depth of 355 ± 10 mm.

5.2.1 Studies have suggested that direct sunlight or artificial

light may adversely influence the results of this test.¹¹ To minimize effects of light exposure on the lubricant being tested, light shall be excluded from the lubricant by one or more of the following ways:

5.2.1.1 Use of heated liquid baths that are designed and

¹¹ Supporting data (a summary of these results) have been filed at ASTM International Headquarters and may be obtained by requesting Research Report RR:D02-1365.

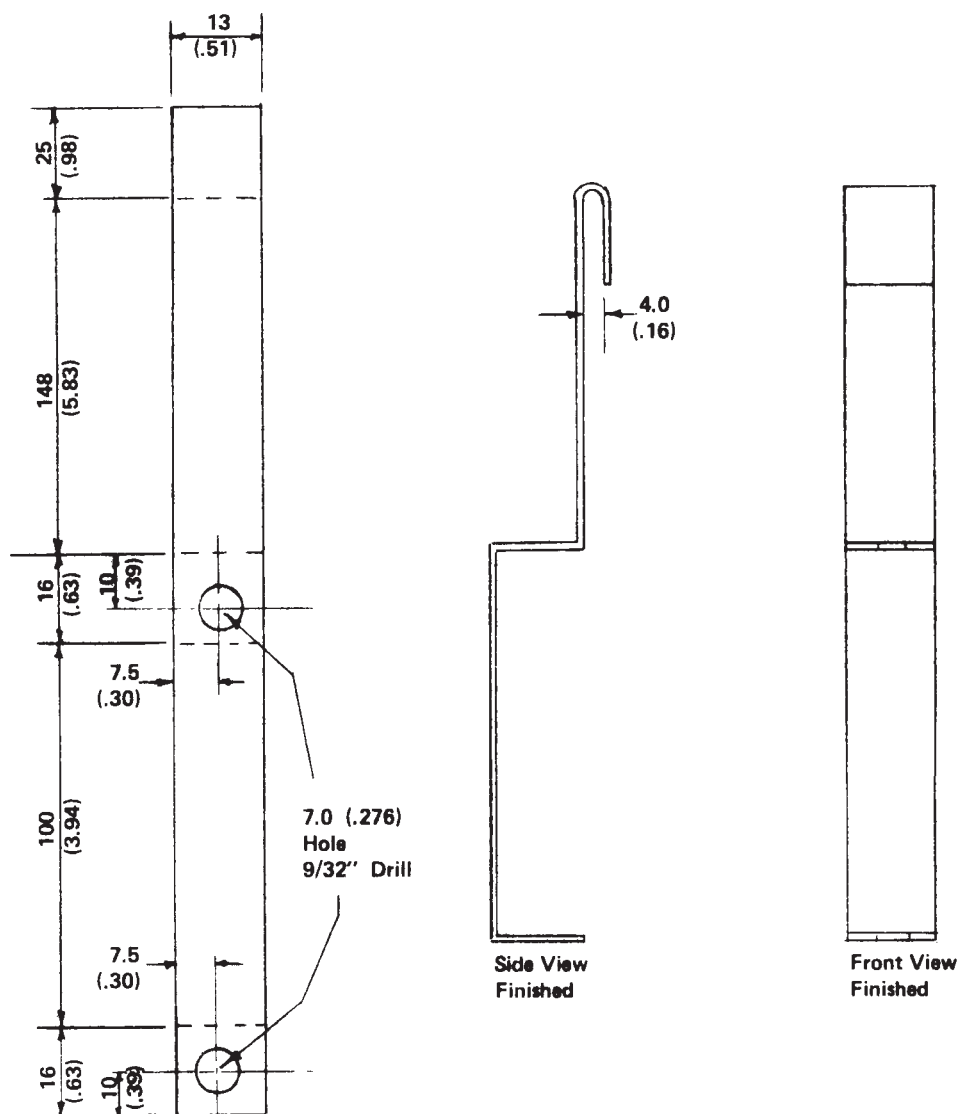

All dimensions are in millimetres (inches).
Material: 18-8 Stainless Steel, 22 Gage (0.792 mm).

FIG. 2 Thermometer Bracket

constructed of metal, or combinations of metals and other suitable opaque materials, that prevent light from entering the test cell from the sides is preferred. If a *viewing window* is included in the design, this *viewing window* shall be fitted with a suitable opaque cover and be kept closed when no observation is being made.

5.2.1.2 If glass heating baths are used, the bath shall be wrapped with aluminum foil or other opaque material.

5.2.1.3 Bright light entering the test cell from directly overhead can be eliminated by use of an opaque shield.

5.3 *Flowmeter*, with a capacity of at least 3 L of oxygen/h, and an accuracy of ± 0.1 L/h.

5.4 *Heating Bath Thermometer*—ASTM Solvents Distillation Thermometer having a range from 72 to 126°C, and conforming to the requirements for Thermometer 40C as prescribed in Specification E 1, or for Thermometer 70C as prescribed in Specifications for IP Standard Thermometers. Alternatively, temperature-measuring devices of equal or better accuracy may be used.

5.5 *Oxidation Cell Thermometer*,⁹ having a range from 80 to 100°C, graduated in 0.1°C, total length—250 mm, stem diameter—6.0 to 7.0 mm, calibrated for 76-mm immersion.¹² Alternatively, temperature-measuring devices of equal or better accuracy may be used.

5.6 *Thermometer Bracket*, for holding the oxidation cell thermometer, of 18-8 stainless steel, having the dimensions shown in Fig. 2. The thermometer is held in the bracket by two fluoroelastomer O-rings of approximately 5 mm inside diameter. Alternatively, thin stainless steel wire may be used.

5.7 *Wire Coiling Mandrel*, as shown in Fig. 3.

5.8 *Abrasive Cloth*, silicon carbide, 100-grit with cloth backing.

¹² The sole source of supply of the Brooklyn thermometer No. 21276-RM known to the committee at this time is the Brooklyn Thermometer Co., Farmingdale, NY. If you are aware of alternative suppliers, please provide this information to ASTM International Headquarters. Your comments will receive careful consideration at a meeting of the responsible technical committee¹, which you may attend.

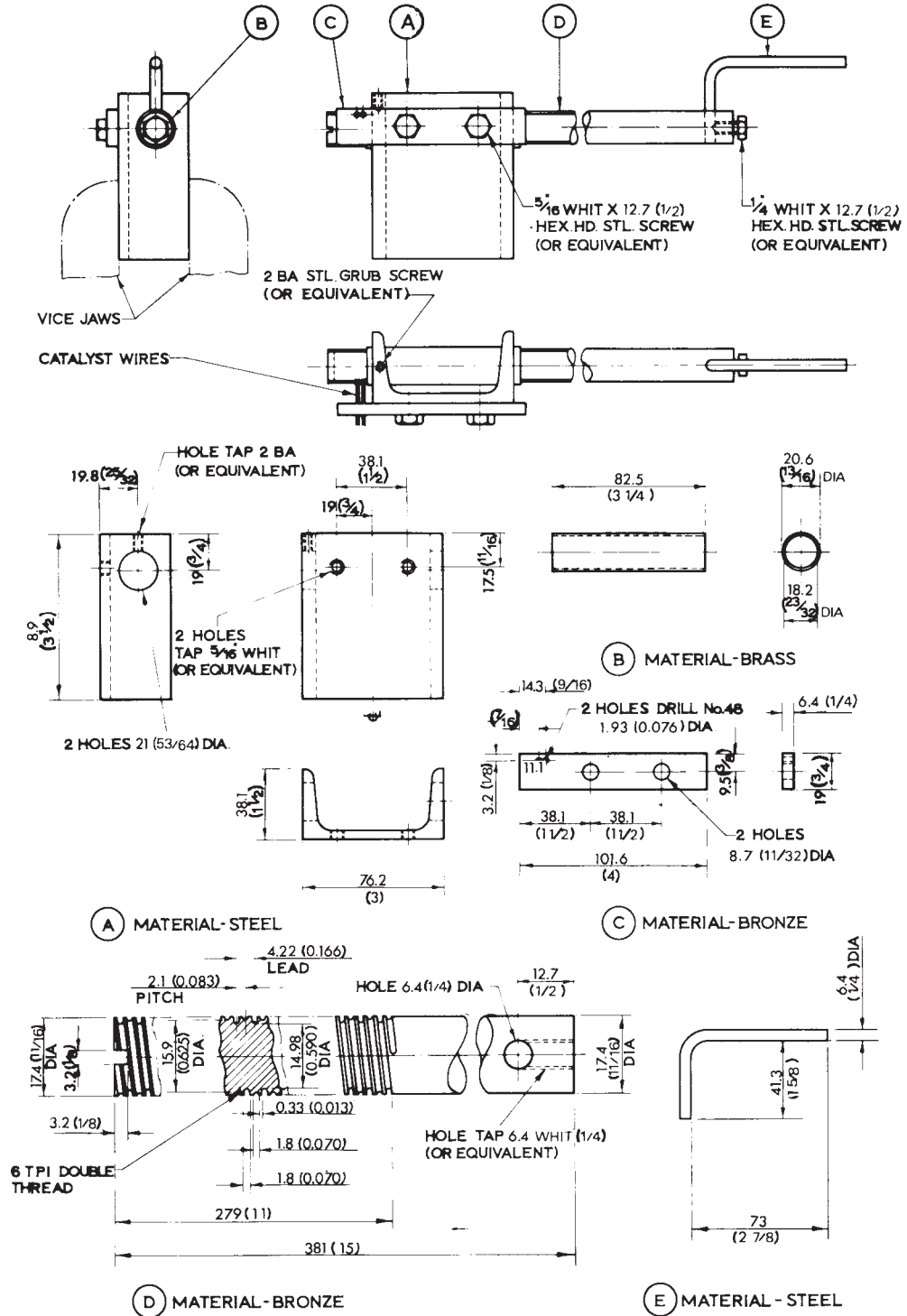

Dimensions are in millimetres (inches).
FIG. 3 Mandrel for Winding Catalyst Coils

5.9 *Syringes*, glass, with Luer-Lok locking connectors, 10 and 50-mL capacities for sampling, and water additions, respectively.

5.10 *Syringe Sampling Tube*, Grade 304 stainless steel tubing, 2.11 mm (0.083 in.) in outside diameter, 1.60 mm (0.063 in.) in inside diameter, 559 ± 2 mm (24.0 ± 0.08 in.) long, with one end finished at 90° and the other end fitted with a Luer-Lok female connector. The Luer-Lok connector is preferably of elastomeric material, such as polyfluorovinylchloride to provide a good seal with the syringe.¹³

5.11 *Stopper*, for Luer fitting of syringe sampling tube, made of polytetrafluoroethylene or polyfluorovinylchloride.¹⁴

5.12 *Sampling Tube Holder*, for supporting the syringe sampling tube, made of methyl methacrylate resin, having the dimensions shown in Fig. 4.

5.13 *Sampling Tube Spacer*, for positioning the end of the sampling tube above the sampling tube holder, made of a length of plastic tubing polyvinyl chloride, polyethylene, polypropylene, or polytetrafluoroethylene having an inside diameter of approximately 3 mm (1/8 in.) and 51 ± 1 mm (2.0 ± 0.04 in.) length.

5.14 *Flexible Tubing*, polyvinyl chloride approximately 6.4 mm (1/4 in.) in inside diameter with a (3/32-in.) wall for delivery of oxygen to the oxidation cell.

6. Reagents and Materials

6.1 *Purity of Water*—Unless otherwise indicated, references to water shall be understood to mean reagent water as defined by Type II of Specification D 1193.

6.2 *Purity of Reagents*—Reagent grade chemicals shall be used in all tests. Unless otherwise indicated, it is intended that all reagents conform to the specifications of the Committee on Analytical Reagents of the American Chemical Society where such specifications are available.¹⁵ Other grades may be used, provided it is first ascertained that the reagent is of sufficiently high purity to permit its use without lessening the accuracy of the determination.

6.3 *Acetone*, reagent grade. (**Warning**—Health hazard; flammable.)

6.4 *Catalyst Wires*:

6.4.1 *Low-Metalloid Steel Wire*¹⁶, 1.59 mm (0.0625 in.) in diameter (No. 16 Washburn and Moen Gage).

6.4.2 *Electrolytic Copper Wire*, 1.63 mm (0.064 in.) in

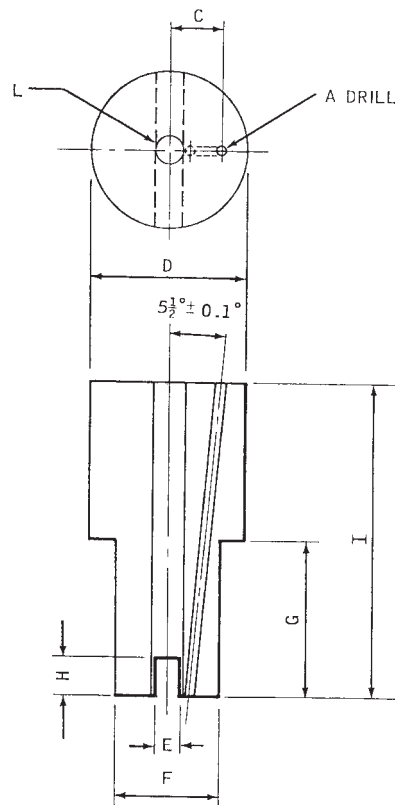

Table of Dimensions

Dimension	mm		in.	
	Dimension	Tolerance	Dimension	Tolerance
A	2.4	0.1	0.09375	0.005
B	7.5	0.1	0.296875	0.005
C	12.7	0.25	0.50	0.01
D	38.1	0.50	1.50	0.02
E	6.4	0.50	0.25	0.02
F	25.4	0.25	1.00	0.01
G	38.1	0.50	1.50	0.02
H	9.5	0.50	0.375	0.02
I	76.2	0.50	3.00	0.02

FIG. 4 Sampling Tube Holder

diameter (No. 16 Imperial Standard Wire Gage or No. 14 American Wire Gage), 99.9 % purity, conforming to Specification B 1. Soft copper wire of an equivalent grade may also be used.

NOTE 2—Alternatively, suitably prepared catalyst coils may be purchased from a supplier.

6.5 *Detergent*, water-soluble.

6.6 *n-Heptane*, reagent grade. (**Warning**—Flammable. Harmful if inhaled.)

6.7 *Hydrochloric Acid*, concentrated [36 mass % (relative density 1.19)]. (**Warning**—Toxic and corrosive.)

6.8 *Isopropyl Alcohol*, reagent grade. (**Warning**—Flammable.)

6.9 *Oxygen*, 99.5 % minimum purity, with pressure regulation adequate to maintain a constant flow of gas through the apparatus. The use of a two-stage pressure regulator on tank oxygen is recommended. (**Warning**—Vigorously accelerates combustion.)

¹³ The sole source of supply of syringe needles with polychloro-trifluoroethylene hub known to the committee at this time is Hamilton Co., catalog number KF-714. If you are aware of alternative suppliers, please provide this information to ASTM International Headquarters. Your comments will receive careful consideration at a meeting of the responsible technical committee¹, which you may attend.

¹⁴ Suitable stoppers are available from suppliers of infrared spectrometer sample cells.

¹⁵ *Reagent Chemicals, American Chemical Society Specifications*, American Chemical Society, Washington, DC. For suggestions on the testing of reagents not listed by the American Chemical Society, see *Analar Standards for Laboratory Chemicals*, BDH Ltd., Poole, Dorset, U.K., and the *United States Pharmacopeia and National Formulary*, U.S. Pharmacopeial Convention, Inc. (USPC), 12601 Twinbrook Pkwy., Rockville, MD 20852.

¹⁶ Carbon steel wire, soft bright annealed and free from rust, of Grade 1008 as described in Specification A 510 is satisfactory. Similar wire conforming to BS 1829 is also satisfactory. If these steels are not available, other equivalent steels may be used, provided they are found to be satisfactory in comparative tests using Test Method D 943.

6.10 *Cleaning Reagent*, cleaning by a 24-h soak at room temperature either in Nochromix¹⁷ (**Warning**—Corrosive. Health Hazard.) or in Micro¹⁸ solution.

7. Sampling

7.1 Samples for this test can come from tanks, drums, small containers, or even operating equipment. Therefore, use the applicable apparatus and techniques described in Practice D 4057.

7.2 For one single determination the minimum required sample size is 300 mL.

8. Preparation of Apparatus

8.1 *Cleaning Catalyst*—Immediately prior to winding a catalyst coil, clean a 3.00 ± 0.01 -m length of iron wire and an equal length of copper wire with wads of absorbent cotton wet with *n*-Heptane and follow by abrasion with abrasive cloth until a fresh metal surface is exposed. Then wipe with dry absorbent cotton until all loose particles of metal and abrasive have been removed. In subsequent operations handle the catalyst wires with clean gloves (cotton, rubber, or plastic) to prevent contact with the skin.

8.2 *Preparation of Catalyst Coil*—Twist the iron and copper wires tightly together at one end for three turns and then wind them simultaneously alongside each other on a threaded mandrel (Fig. 3), inserting the iron wire in the deeper thread. Remove the coil from the mandrel, twist the free ends of the iron and copper wires together for three turns, and bend the twisted ends to conform to the shape of the spiral coil. The overall length of the finished coil should be 225 ± 5 mm (8.9 ± 0.2 in.). If necessary, the coil may be stretched to give the required length (Note 2 and Note 3.)

NOTE 3—The finished catalyst coil is a double spiral of copper and iron wire, 225 ± 5 mm (8.9 ± 0.2 in.) overall length and 15.9 to 16.5 mm (0.625 to 0.650 in.) inside diameter. The turns of wire are evenly spaced, and two consecutive turns of the same wire are 3.96 to 4.22 mm (0.156 to 0.166 in.) apart, center to center. The mandrel shown in Fig. 3 is designed to produce such a coil. Using this mandrel, the iron wire is wound on a thread of 14.98-mm (0.590-in.) diameter, while the copper wire is wound on a thread of 15.9-mm (0.625-in.) diameter. The smaller diameter is to allow for *springback* of the steel wire after winding, so as to give 15.9-mm consistent inside diameter. Use of a very soft annealed steel wire may allow use of identical thread diameters for the two wires. Any arrangement that leads to the coil configuration described above is satisfactory.

8.3 *Catalyst Storage*—The catalyst coil may be stored in a dry, inert atmosphere prior to use. A suitable procedure for catalyst storage is given in Appendix X1. Before use it should be inspected to assure that no corrosion products or contaminating materials are present. For overnight storage (less than 24 h) the coil may be stored in *n*-Heptane.

8.3.1 *n*-Heptane used for catalyst storage must be free of traces of water and corrosive materials. Redistilled *n*-Heptane conforming to 6.6 and stored in a tightly sealed bottle is suitable.

8.4 *Cleaning New Glassware*—Wash new oxygen delivery tubes, condensers, and test tubes with a hot detergent solution and rinse thoroughly with tap water. Clean the interiors of the test tubes, exteriors of the condensers, and both interiors and exteriors of the oxygen delivery tubes with cleaning reagent. Rinse thoroughly with tap water until all cleaning solution is removed. Rinse all parts with reagent water and allow to dry at room temperature or in an oven. The final reagent water rinse may be followed by an isopropyl alcohol rinse, or acetone rinse, optionally followed by dry air blowing, to hasten drying at room temperature.

8.5 *Cleaning Used Glassware*—Immediately following termination of a test, drain the oil completely from the test tube. Rinse all the glassware with *n*-Heptane to remove traces of oil, wash with a hot detergent solution using a long-handled brush, and rinse thoroughly with tap water. If deposits still adhere to the glassware, a method that has been found useful is to fill the test tubes with detergent solution, insert the oxygen delivery tubes and condensers, and place the tubes in the bath at test temperature. Several hours soaking in this manner often serves to loosen all adhering deposits except iron oxide. Subsequent rinsing with hot (50°C) hydrochloric acid will serve to remove iron oxide. After all deposits are removed, rinse all glassware with a cleaning reagent. Rinse thoroughly with tap water until all acid is removed. Rinse all parts with reagent water and allow to dry at room temperature or in an oven. The final reagent water rinse may be followed by an isopropyl alcohol rinse, or acetone rinse, optionally followed by dry air blowing, to hasten drying at room temperature. Store glassware in a dry dust-free condition until ready to use.

8.6 *Cleaning Used Sampling Tube*—Immediately following termination of a test, drain the oil completely from the sampling tube. Rinse the tube with *n*-Heptane to remove traces of oil and any tenacious organic residues. Repeat the rinsing procedure with *n*-Heptane and blow dry with air or nitrogen.

9. Procedure

9.1 Adjust the heating bath to a temperature high enough to maintain the oil in the oxidation test cell at the required temperature of $95 \pm 0.2^\circ\text{C}$.

9.2 Fill the empty oxidation test tube with 300 mL of the oil sample to the graduation mark. Slide the catalyst coil over the inlet of the oxygen delivery tube. If the wires are uneven at one end of the coil, position the coil so that this end is down. Place the oxygen delivery tube with the coil into the test tube. Place the condenser over the oxygen delivery tube and test tube. Place the sampling tube holder over the oxygen delivery tube. Insert the syringe sampling tube through the syringe sampling tube spacer, and into the sampling tube holder, as shown in Fig. 5. Position the bottom end of the sampling tube inside the catalyst coil. Insert a stopper in the Luer-Lok fitting end of the sampling tube. Immerse the test tube in the heating bath. Adjust the heating bath liquid level so that the tube is immersed in the liquid to a depth of 355 ± 10 mm. Connect the condenser to the cooling water. The temperature of the outlet water should

¹⁷ The sole source of supply of Nochromix known to the committee at this time is Godax Laboratories, Inc., 720-B Erie Ave., Takoma Park, MD 20912. If you are aware of alternative suppliers, please provide this information to ASTM International Headquarters. Your comments will receive careful consideration at a meeting of the responsible technical committee¹, which you may attend.

¹⁸ The sole source of supply of the Micro solution known to the committee at this time is International Products Corp., P.O. Box 70, Burlington, NJ 08016. If you are aware of alternative suppliers, please provide this information to ASTM International Headquarters. Your comments will receive careful consideration at a meeting of the responsible technical committee¹, which you may attend.

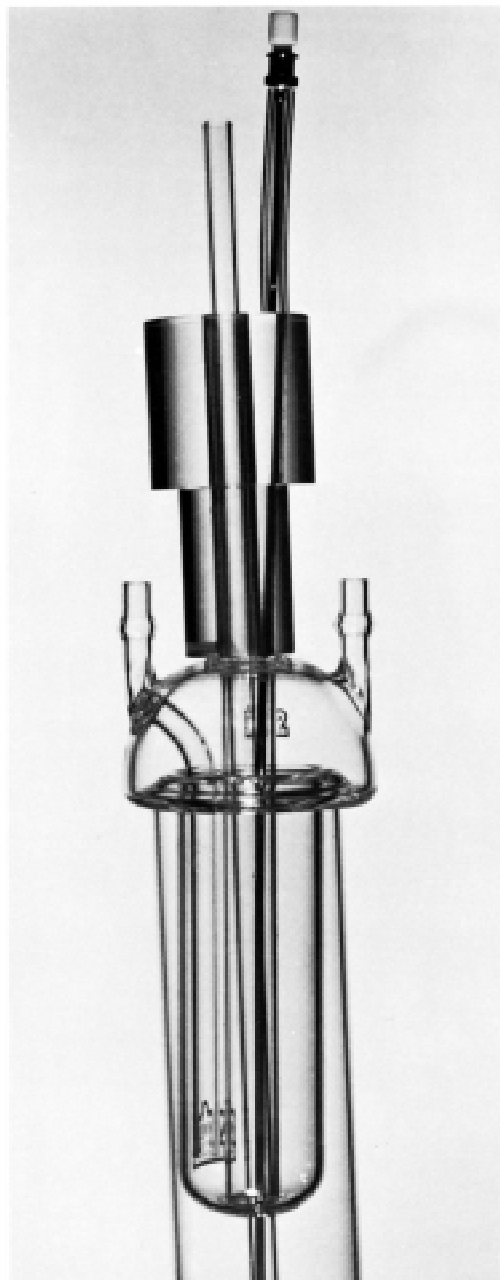

FIG. 5 Oxidation Cell with Sampling Tube

not exceed 32°C at any time during the test.

NOTE 4—As an alternative to using the sampling tube holder and sampling tube spacer, the sampling tube may be secured in position by taping or clamping to the oxygen delivery tube using a suitable adhesive tape or clamp. The sampling tube is taped or clamped to the oxygen delivery tube at a distance of approximately 25 mm (1 in.) above the top of the condenser. The bottom of the sampling tube is positioned at 152 ± 6 mm (6 ± 0.25 in.) from the bottom curved end of the oxygen delivery tube.

9.3 Connect the oxygen delivery tube to the oxygen supply (see 6.9) through the flowmeter using new polyvinyl chloride flexible tubing no more than 600 mm in length. Before using, the interior of the new tubing should be rinsed with *n*-Heptane and blown dry with air. Adjust the rate of flow to 3 ± 0.1 L and

continue flow for 30 min.

9.4 Raise the condenser unit from the oxidation cell and add 60 mL of reagent water through the opening thus provided. The test is considered to start at this point.

9.5 Throughout the duration of the test, maintain the temperature of the oil-water mixture (sample temperature) at $95 \pm 0.2^\circ\text{C}$ in each test cell with oxygen flowing. Accomplish this by maintaining the bath at the temperature that is found necessary to give the required 95°C sample temperature. The temperature of the bath is always higher than the sample temperature due to the cooling effect of the oxygen gas flow, and depends on heating bath medium, capacity, circulation, and on the number of tests cells in the bath. Measure the sample temperature by a thermometer positioned in the oxidation cell by a thermometer bracket, as in Fig. 6 (Note 5). Make temperature measurements only with new, undepleted, oil samples, and preferably with dummy cells used specifically for temperature measurement. When an actual test sample is used, remove the thermometer immediately after temperature measurement is complete. Check the temperature in this way in various parts of a multiple-cell bath to verify uniformity of temperature control. Once the required bath temperature is found, maintain at that temperature $\pm 0.2^\circ\text{C}$.

NOTE 5—With the arrangement shown in Fig. 6, the 76-mm immersion point of the thermometer is positioned at the oil surface. To allow for heating of the stem portion of the thermometer above the immersion point in the upper portion of the test cell, subtract 0.10°C from the thermometer reading to obtain the true test temperature.

9.6 Add additional reagent water to the oxidation cell as required (Note 6), at least every 2 weeks during the test, to restore the water level to the shoulder of the oxygen delivery tube. Add the water using the sampling tube and the 50-mL capacity syringe.

NOTE 6—Under some circumstances, the level of water cannot be observed because of deposits or emulsion formation. Marking the upper oil level of the filled oxidation tube by some suitable means and maintaining this level by periodic water additions will keep the proper amount of water in the cell. The correct level for water additions may, if desired, be indicated by a movable metal strip (Fig. 7), which is clamped to the outside of the oxidation test tube by, for example, an adjustable ring-type hose clamp. To use this indicator, the lower end of the strip is set at the upper oil level when the test is started. As the test proceeds and water evaporates to cause the oil level to fall, sufficient makeup water is added, particularly just before oil samples are taken, to return the oil level to the level marked by the indicator strip. After each oil sample is taken, the indicator is moved to the new oil level before continuing the test.

9.7 Monitor the oil for signs of oxidation by periodically withdrawing samples for measurement of acid number.

9.7.1 After 500 h of test time, and every 168 h (every week) thereafter, withdraw 3 mL of test oil from the oxidation test cell (Note 7). This can be accomplished as follows. Without interrupting the oxygen flow, and without changing the position of the sampling tube, remove the sampling tube stopper and twice draw out into the syringe and return approximately 3 mL of test oil to the test cell in order to flush out the sampling tube. Then withdraw 6 mL of test oil into the syringe, hold the syringe tube vertically for 15 to 20 s to allow water to settle to the bottom of the syringe tube, and adjust the sample size to 3 mL while holding the syringe vertically. This method allows

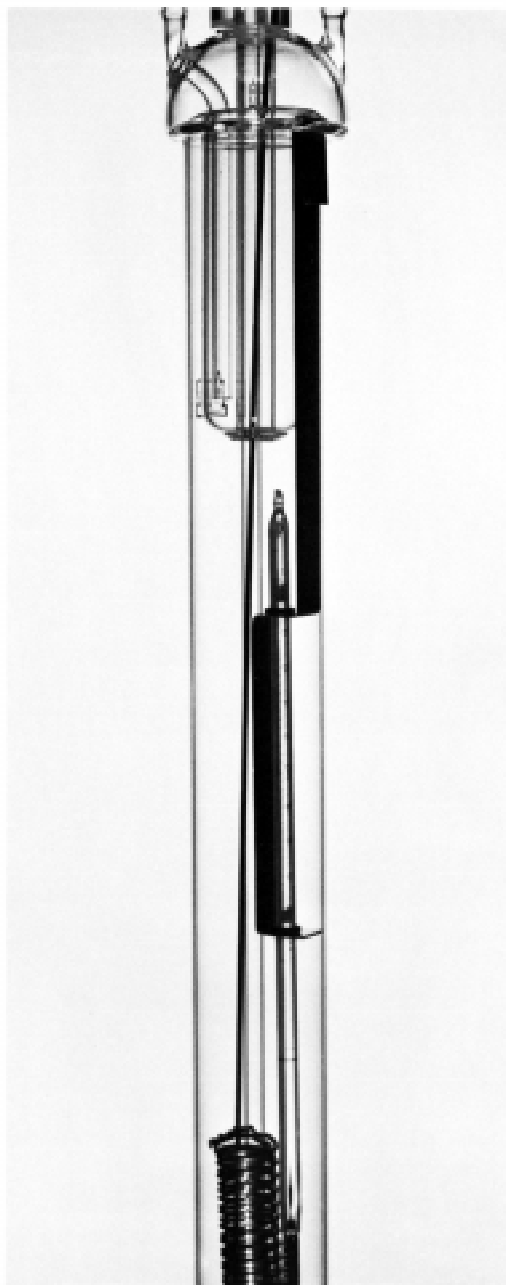

FIG. 6 Oxidation Cell with Thermometer

most of the water withdrawn with the test oil to be returned to the test cell. Replace the sampling tube stopper. The 3-mL sample is dispensed into a sample vial for acid number analysis by Test Methods D 3339 or D 5770 (Note 8). Shake the test oil sample thoroughly before taking a sample from the vial for titration.

NOTE 7—Test results by this method are greatly affected by differences in sampling procedure. It is important to strictly adhere to the procedure and schedule for sampling for acid number. An exception is where the oil is known to have a life shorter than 500 h, the sampling is at the discretion of the operator.

NOTE 8—Test Method D 5770 is preferred but Test Method D 3339 is permitted when the acid number is no greater than 0.50 mg KOH/g oil. Use Test Method D 3339 when the acid number exceeds 0.50. Test

Methods D 3339 and D 5770 use a color change to indicate the titration end point. For dark-colored oils, the use of potentiometric titration (such as Test Method D 664) to measure the end point may be advantageous. It is recognized that there is no ASTM semi-micro method now available for potentiometric titration.

9.7.2 After 3000 h, take monitoring samples at 500 ± 25 h intervals.

9.7.3 When observation indicates that the oil is nearing the end of its test life, additional samples may be taken at the discretion of the operator.

9.8 Discontinue the test when the measured acid number is 2.0 mg KOH/g or above (Note 9).

NOTE 9—The value 2.0 mg KOH/g is taken as the limiting value when testing steam-turbine oils by this method. When oxidation is proceeding rapidly in such oils, values much higher than 2.0 are frequently encountered. At that time, the state of severe oxidation of the oil, as indicated by the high acid number, is generally confirmed by other signs of degradation such as disagreeable odor, formation of deposits, corrosion of the catalyst coil, severe darkening of the oil, and emulsification of the oil-water mixture. If such signs of oxidation are noted before the scheduled time for sampling for acid number, a sample may be taken then and the test discontinued if the measured acid number is 2.0 mg KOH/g or above.

9.8.1 If the acid number is still less than 2.0 mg KOH/g oil after 10 000 h, the test should be terminated. Report the test life and acid number as $10\ 000 + h$ ($AN = x.xx$) (Note 10).

NOTE 10—Beyond 10 000 h, oil removal causes the metal catalyst coil to be exposed to the atmosphere. The effect of such exposure on oil life has not been determined, nor has the method precision been determined by cooperative testing.

10. Calculation

10.1 Calculate the hours to 2.0 mg KOH/g acid number (oxidation lifetime) H , as follows:

$$H = A + [(2.0 - C)/(D - C)] \times (B - A) \quad (1)$$

where:

A = number of test hours when acid number was last measured below 2.0,

B = number of test hours when acid number was measured above 2.0,

C = acid number at A hours, and

D = acid number at B hours.

11. Report

11.1 Report the calculated hours to 2.0 mg KOH/g acid number (oxidation lifetime).

12. Precision¹⁹

12.1 The following criteria should be used for judging the acceptability of results (95 % confidence) in the data range from 700 to 3900 h:

12.1.1 *Repeatability*—The difference between concurrent test results obtained by the same operator with the same apparatus under constant operating conditions on identical test materials, would, in the long run, and in the normal and correct operation of the test method, exceed the following values only in 1 case in 20:

¹⁹ Supporting data have been filed at ASTM International Headquarters and may be obtained by requesting Research Report RR:D02-1026.

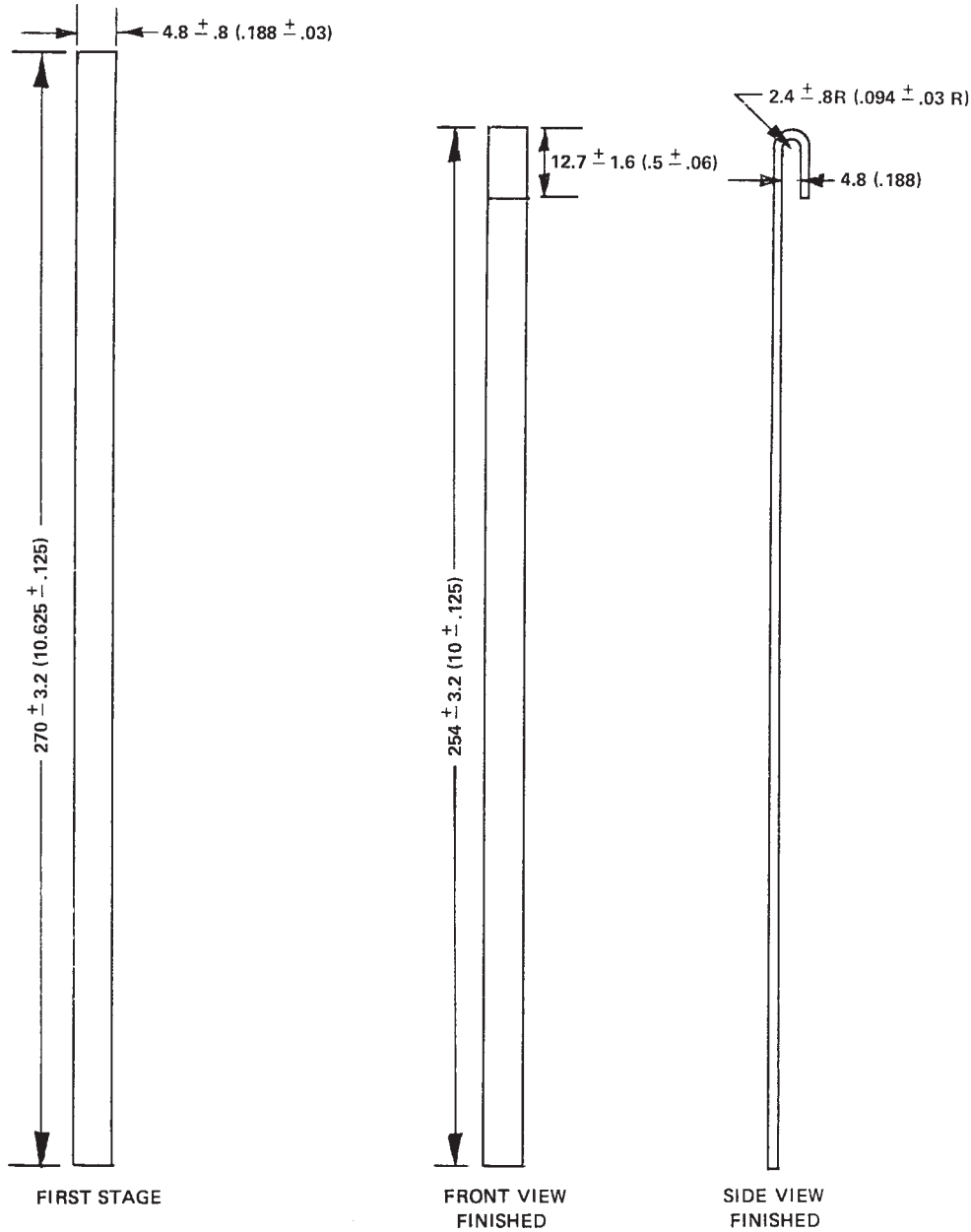

All dimensions are in millimetres (inches).
Material: Type 304 Stainless Steel, 22 Gage (0.792 mm).

FIG. 7 Oil Level Indicator Strip

$$0.192 \bar{x} \quad (2)$$

where:

\bar{x} = denotes mean value.

12.1.2 *Reproducibility*—The difference between two single and independent results, obtained by different operators working in different laboratories on identical test material, would, in the long run, and in the normal and correct operation of the test method, exceed the following values only in one case in 20:

$$0.332 \bar{x} \quad (3)$$

where:

\bar{x} = denotes mean value.

NOTE 11—*Reproducibility with Duplicate Tests*—If two successive tests are performed by each operator in 12.1.2, the difference between the

averages of the two sets of results from the tests would exceed the following values in one case in 20:

$$0.302 \bar{x} \quad (4)$$

where:

\bar{x} = denotes the mean value of the averaged results from the two laboratories.

If more than two results are obtained by one or both of the laboratories, reproducibility can be calculated as indicated in 4.4 of Practice D 3244.

13. Keywords

13.1 acid number; circulating oils; corrosion; hydraulic oils; inhibited steam-turbine oils; iron-coffer catalyst; metal catalyst; oxidation; oxidation lifetime; oxidation stability; test life; turbine oils

APPENDIX

(Nonmandatory Information)

X1. PROCEDURE FOR PACKAGING CATALYST COILS

X1.1 Materials

X1.1.1 *Test Tubes*, borosilicate glass, 250-mm length, 25-mm outside diameter, approximately 22-mm inside diameter.

X1.1.2 *Caps*, for test tubes, polyethylene cylindrical shape designed to closely grip outside surface of test tube.

X1.1.3 *Desiccant Bags*, of silica gel granules.

X1.1.4 *Flushing Tube*, stainless steel or glass, approximately 5 mm ($\frac{3}{16}$ in.) outside diameter, 305 mm (12 in.) long, to deliver nitrogen to bottom of test tube.

X1.1.5 *Nitrogen Gas*, 99.7 % minimum purity. (**Warning**—Compressed gas under high pressure. Gas reduces oxygen

available for breathing.)

X1.2 Procedure

X1.2.1 Flush a new test tube with nitrogen gas, using the flushing tube, to blow out any loose particles. The tube must be visibly clean and dry. Hold the tube on an angle and gently slide the catalyst coil into the tube. Add a desiccant bag that has been folded lengthwise to fit in the tube. Insert the nitrogen flushing tube down the middle of the test tube, to the bottom, and blow nitrogen through the tube for several seconds. Immediately after withdrawing the flushing tube, seal the test tube with a polyethylene cap.

ASTM International takes no position respecting the validity of any patent rights asserted in connection with any item mentioned in this standard. Users of this standard are expressly advised that determination of the validity of any such patent rights, and the risk of infringement of such rights, are entirely their own responsibility.

This standard is subject to revision at any time by the responsible technical committee and must be reviewed every five years and if not revised, either reapproved or withdrawn. Your comments are invited either for revision of this standard or for additional standards and should be addressed to ASTM International Headquarters. Your comments will receive careful consideration at a meeting of the responsible technical committee, which you may attend. If you feel that your comments have not received a fair hearing you should make your views known to the ASTM Committee on Standards, at the address shown below.

This standard is copyrighted by ASTM International, 100 Barr Harbor Drive, PO Box C700, West Conshohocken, PA 19428-2959, United States. Individual reprints (single or multiple copies) of this standard may be obtained by contacting ASTM at the above address or at 610-832-9585 (phone), 610-832-9555 (fax), or service@astm.org (e-mail); or through the ASTM website (www.astm.org).