



Standard Test Method for Measurement of the Effects of Automotive Engine Oils on the Fuel Economy of Passenger Cars and Light-Duty Trucks in the Sequence VIB Spark Ignition Engine^{1,2}

This standard is issued under the fixed designation D 6837; the number immediately following the designation indicates the year of original adoption or, in the case of revision, the year of last revision. A number in parentheses indicates the year of last reapproval. A superscript epsilon (ε) indicates an editorial change since the last revision or reapproval.

INTRODUCTION

The test method described in this standard can be used by any properly equipped laboratory, without outside assistance. However, the STEM Test Monitoring Center (TMC)³ provides reference oils and assessment of the test results obtained on those oils by the laboratory (see Annex A1). By this means, the laboratory will know whether their use of the test method gives results statistically similar to those obtained by other laboratories. Furthermore, various agencies require that a laboratory utilize the TMC services in seeking qualification of oils against specifications. For example, the American Petroleum Institute (API) imposes such a requirement, in connection with several U.S. Army engine lubricating oil specifications.

Accordingly, this test method is written for use by laboratories, which utilize the TMC services. Laboratories which choose not to use those services may simply ignore those portions of the test method which refer to the TMC.

This test method may be modified by means of Information Letters issued by the TMC. In addition, the TMC may issue supplementary memoranda related to the test method. Users of this test method shall contact the TMC, Attention: Administrator, to obtain the most recent of these.

1. Scope

1.1 This test method covers an engine test procedure for the measurement of the effects of automotive engine oils on the fuel economy of passenger cars and light-duty 3856 kg (8500 lb) or less gross vehicle weight trucks. The tests are conducted using a specified 4.6-L spark-ignition engine on a dynamometer test stand. It applies to multiviscosity grade oils used in these applications.

1.2 This test method also provides for the running of an abbreviated length test that is referred to as the VIBSJ. The procedure for VIBSJ is identical to the Sequence VIB with the

exception of the items specifically listed in Annex A13. The procedure modifications listed in Annex A13 refer to the corresponding section of the Sequence VIB test method.

1.3 The unit values stated in this test method shall be regarded as the standard. Values given in parentheses are provided for information purposes only. SI units are considered the primary units for this test method. The only exception is where there is no direct SI equivalent such as screw threads, national pipe threads/diameters, tubing size, and so forth.

1.4 *This standard does not purport to address all of the safety concerns, if any, associated with its use. It is the responsibility of the user of this standard to establish appropriate safety and health practices and determine the applicability of regulatory limitations prior to use.*

1.5 This test method is arranged as follows:

Subject	Section
Introduction	
Scope	1
Referenced Documents	2
Terminology	3
Summary of Test Method	4
Significance and Use	5
Apparatus	6
General	6.1
Test Engine Configuration	6.2
Laboratory Ambient Conditions	6.3
Engine Speed and Load Control	6.4

¹ This test method is under the jurisdiction of ASTM Committee D02 on Petroleum Products and Lubricants and is the direct responsibility of Subcommittee D02.B0 on Automotive Lubricants.

Current edition approved Nov. 1, 2003. Published November 2003. Originally approved in 2002. Last previous edition approved in 2002 as D 6837 – 02.

² The multi-cylinder engine test sequences were originally developed in 1956 by an ASTM Committee D02 group. Subsequently, the procedures were published in an ASTM special technical publication. The Sequence VIB was published as Research Report RR:D02-1469 dated April 8, 1999.

³ ASTM Test Monitoring Center, 6555 Penn Avenue, Pittsburgh, PA 15206-4489. For other information, refer to Research Report RR: D02:1469, Sequence VIB Test Development. This research report and this test method are supplemented by Information Letters and Memoranda issued by the ASTM TMC. This edition incorporates revisions in all Information Letters through No. 03-2.

Subject	Section	Subject	Section
Dynamometer	6.4.1	Fuel Injection System	9.3.17
Dynamometer Load	6.4.2	Intake Air System	9.3.18
Engine Cooling System	6.5	Engine Management System (Spark and Fuel Control)	9.3.19
External Oil System	6.6	Accessory Drive Units	9.3.20
Fuel System	6.7	Exhaust Manifolds	9.3.21
Fuel Flow Measurement	6.7.2	Engine Flywheel and Guards	9.3.22
Fuel Temperature and Pressure Control to the Fuel Flow Meter	6.7.3	Lifting of Assembled Engines	9.3.23
Fuel Temperature and Pressure Control to Engine Fuel Rail	6.7.4	Engine Mounts	9.3.24
Fuel Supply Pumps	6.7.5	Calibration	10
Fuel Filtering	6.7.6	Stand/Engine Calibration	10.1
Engine Intake Air Supply	6.8	Procedure	10.1.1
Intake Air Humidity	6.8.1	Reporting of Reference Results	10.1.2
Intake Air Filtration	6.8.2	Analysis of Reference/Calibration Oils	10.1.3
Intake Air Pressure Relief	6.8.3	Instrument Calibration	10.2
Temperature Measurement	6.9	Engine Load Measurement System	10.2.1
Thermocouple Location	6.9.5	Fuel Flow Measurement System	10.2.2
AFR Determination	6.10	Coolant Flow Measurement System	10.2.3
Exhaust and Exhaust Back Pressure Systems	6.11	Thermocouple and Temperature Measurement System	10.2.4
Exhaust Manifolds	6.11.1	Humidity Measurement System	10.2.5
Laboratory Exhaust System	6.11.2	Other Instrumentation	10.2.6
Exhaust Back Pressure	6.11.3	Test Procedure	11
Pressure Measurement and Pressure Sensor Locations	6.12	Preparation for Initial Start-up of New Engine	11.1
Engine Oil	6.12.2	External Oil System	11.1.1
Fuel to Fuel Flow Meter	6.12.3	Flush Effectiveness Demonstration	11.1.2
Fuel to Engine Fuel Rail	6.12.4	Preparation for Oil Charge	11.1.3
Exhaust Back Pressure	6.12.5	Oil Charge for Coolant Flush	11.1.4
Intake Air	6.12.6	Engine Coolant Charge for Coolant Flush	11.1.5
Intake Manifold Vacuum/Absolute Pressure	6.12.7	Initial Engine Start-up	11.2
Coolant Flow Differential Pressure	6.12.8	Coolant Flush	11.3
Crankcase Pressure	6.12.9	New Engine Break-In	11.4
Engine Hardware and Related Apparatus	6.13	Oil Charge for Break-In	11.4.2
Test Engine Configuration	6.13.1	Break-In Operating Conditions	11.4.3
ECM/EEC (Engine Control) Module	6.13.2	Routine Test Operation	11.5
Thermostat/Orifice Plate	6.13.3	Start-Up and Shutdown Procedures	11.5.8
Intake Manifold	6.13.4	Flying Flush Oil Exchange Procedures	11.5.9
Flywheel	6.13.5	Test Operating Stages	11.5.10
Wiring Harnesses	6.13.6	Stabilization to Stage Conditions	11.5.11
EGR Block-Off Plate	6.13.7	Stabilized BSFC Measurement Cycle	11.5.12
Oil Pan	6.13.8	Data Logging	11.5.13
Oil Pump Screen and Pickup Tube	6.13.9	BC Oil Flush Procedure for BC Oil Before Test Oil	11.5.14
Idle Speed Control Solenoid (ISC) Block-Off Plate	6.13.10	BSFC Measurement of BC Oil Before Test Oil	11.5.15
Engine Water Pump	6.13.11	Test Oil Flush Procedure	11.5.16
Thermostat Housing	6.13.12	Test Oil Aging	11.5.17
Oil Filter Adapter	6.13.13	BSFC Measurement of Aged (Phase I) Test Oil	11.5.18
Fuel Rail	6.13.14	Aging Phase II	11.5.19
Miscellaneous Apparatus Related to Engine Operation	6.14	BSFC Measurement of Aged (Phase II) Test Oil	11.5.21
Timing Light	6.14.1	BC Oil Flush Procedure for BC Oil After Test Oil	11.5.22
Reagents and Materials	7	BSFC Measurement for BC Oil After Test Oil	11.5.23
Engine Oil	7.1	General Test Data Logging Forms	11.5.24
Test Fuel	7.2	Diagnostic Review Procedures	11.5.25
Engine Coolant	7.3	Determination of Test Results	12
Cleaning Materials	7.4	FEI1 and FEI2 Calculations	12.1
Preparation of Apparatus	8	Final Test Report	13
Test Stand Preparation	8.2	Validity Statement	13.1
Engine Preparation	9	Report Format	13.2
Cleaning of Engine Parts	9.2	Precision and Bias	14
Engine Assembly Procedure	9.3	Precision	14.1
General Assembly Instructions	9.3.1	Validity	14.2
Bolt Torque Specifications	9.3.2	Test Stand Calibration Status	14.2.1
Sealing Compounds	9.3.3	Validity Interpretation of Deviant Operational Conditions	14.2.2
Harmonic Balancer	9.3.5	Bias	14.3
Oil Pan	9.3.6	Keywords	15
Intake Manifold	9.3.7	Annexes	
Camshaft Covers	9.3.8	Role of ASTM TMC	Annex A1
Thermostat	9.3.9	Detailed Specifications and Drawings of Apparatus	Annex A2
Thermostat Housing	9.3.10	Oil Heater Cerrobath Refill Procedure	Annex A3
Coolant Inlet	9.3.11	Engine Part Number Listing	Annex A4
Oil Filter Adapter	9.3.12	Flying Flush Checklists	Annex A5
Dipstick Tube	9.3.13	Safety Precautions	Annex A6
Water Pump	9.3.14	Report Format	Annex A7
Sensors, Switches, Valves, and Positioners	9.3.15	Statistical Equations for Mean and Standard Deviations	Annex A8
Ignition System	9.3.16		

Subject	Section
Oil Sump Full Level Determination Consumption Measurement Calibration Procedure	Annex A9
Fuel Injector Evaluation	Annex A10
Pre-test Maintenance Checklist	Annex A11
Blow-by Ventilation System Requirements	Annex A12
VIBSJ Abbreviated Length Test Requirements	Annex A13
Appendix	
Procurement of Test Materials	Appendix X1

2. Referenced Documents

2.1 ASTM Standards:⁴

- D 86 Test Method for Distillation of Petroleum Products at Atmospheric Pressure
- D 240 Test Method for Heat of Combustion of Liquid Hydrocarbon Fuels by Bomb Calorimeter
- D 287 Test Method for API Gravity of Crude Petroleum and Petroleum Products (Hydrometer Method)
- D 323 Test Method for Vapor Pressure of Petroleum Products (Reid Method)
- D 381 Test Method for Gum Content in Fuels by Jet Evaporation
- D 445 Test Method for Kinematic Viscosity of Transparent and Opaque Liquids (and the Calculation of Dynamic Viscosity)
- D 525 Test Method for Oxidation Stability of Gasoline (Induction Period Method)
- D 1319 Test Method for Hydrocarbon Types in Liquid Petroleum Products by Fluorescent Indicator Absorption
- D 2699 Test Method for Research Octane Number of Spark-Ignition Engine Fuel
- D 3231 Test Method for Phosphorus in Gasoline
- D 3237 Test Method for Lead in Gasoline by Atomic Absorption Spectrometry
- D 3338 Test Method of Estimation of Net Heat of Combustion of Aviation Fuels
- D 4294 Test Method for Sulfur in Petroleum and Petroleum Products by Energy-Dispersive X-ray Fluorescence Spectrometry
- D 4485 Specification for Performance of Engine Oils
- D 5302 Test Method for Evaluation of Automotive Engine Oils for Inhibition of Deposit Formation and Wear in a Spark-Ignition Internal Combustion Engine Fueled with Gasoline and Operated Under Low-Temperature, Light-Duty Conditions
- D 5533 Test Method for Evaluation of Automotive Engine Oils in the Sequence III E, Spark-Ignition Engine
- D 5844 Test Method for Evaluation of Automotive Engine Oils for Inhibition of Rusting (Sequence IID)
- D 5862 Test Method for Evaluation of Engine Oils in Two-Stroke Cycle Turbo-Supercharged 6V92TA Diesel Engine
- D 6202 Test Method for Automotive Engine Oils on the Fuel Economy of Passenger Cars and Light-Duty Trucks in the Sequence VIA Spark Ignition Engine

- D 6557 Test Method for Evaluation of Rust Preventive Characteristics of Automotive Engine Oils
- E 29 Practice for Using Significant Digits in Test Data to Determine Conformance with Specifications
- E 191 Specification for Apparatus for Microdetermination of Carbon and Hydrogen in Organic and Organo-Metallic Compounds
- IEEE/ASTM SI-10 Standard for Use of the International System of Units (SI): The Modern Metric System

2.2 SAE Standards:⁵

- J300 Engine Oil Viscosity Classification
- J304 Engine Oil Tests
- J1423 Classification of Energy-Conserving Engine Oil for Passenger Cars and Light-Duty Trucks

2.3 API Publication:⁶

- API 1509 Engine Oil Licensing and Certification System

2.4 ANSI Standard:⁷

- ANSI MC96.1-1975 Temperature Measurement – Thermocouples

3. Terminology

3.1 Definitions:

3.1.1 *air-fuel ratio, n*—in internal combustion engines, the mass ratio of air-to-fuel in the mixture being induced into the combustion chambers. **D 5302**

3.1.2 *automotive, adj*—descriptive of equipment associated with self-propelled machinery, usually vehicles driven by internal combustion engines. **D 4485**

3.1.3 *blowby, n*—in internal combustion engines, the combustion products and unburned air-and-fuel mixture that enter the crankcase. **D 5302**

3.1.4 *BTDC, adj*—abbreviation for Before Top Dead Center, used with the degree symbol to indicate the angular position of the crankshaft relative to its position at the point of uppermost travel of the piston in the cylinder. **D 5533**

3.1.5 *calibrate, v*—to determine the indication or output of a measuring device or a given engine with respect to a standard. **D 5862**

3.1.6 *calibration oil, n*—an oil that is used to determine the indication or output of a measuring device or a given engine with respect to a standard. **D 6202**

3.1.7 *engine oil, n*—a liquid that reduces friction or wear, or both, between the moving parts of an engine; removes heat, particularly from the underside of pistons; and serves as a combustion gas sealant for the piston rings. **D 5862**

3.1.8 *lubricant, n*—any material interposed between two surfaces that reduces the friction or wear, or both, between them. **D 5862**

3.1.9 *non-reference oil, n*—any oil other than a reference oil, such as a research formulation, commercial oil, or candidate oil. **D 5844**

⁵ Available from Society of Automotive Engineers (SAE), 400 Commonwealth Dr., Warrendale, PA 15096-0001. This standard is not available separately. Either order the SAE Handbook Vol. 3, or the SAE Fuels and Lubricants Standards Manual HS-23.

⁶ Available from The American Petroleum Institute (API), 1220 L. St., NW, Washington, DC 20005.

⁷ Available from American National Standards Institute (ANSI), 25 W. 43rd St., 4th Floor, New York, NY 10036.

⁴ For referenced ASTM standards, visit the ASTM website, www.astm.org, or contact ASTM Customer Service at service@astm.org. For Annual Book of ASTM Standards volume information, refer to the standard's Document Summary page on the ASTM website.

3.1.10 *purchaser, n*—of an ASTM test, a person or organization that pays for the conduct of an ASTM test method on a specified product.

3.1.10.1 *Discussion*—The preferred term is purchaser. Deprecated terms that have been used are client, requester, sponsor, and customer. **D 6202**

3.1.11 *reference oil, n*—an oil of known performance characteristics used as a basis for comparison. **D 5844**

3.1.12 *test oil, n*—any oil subjected to evaluation in an established procedure. **D 6557**

3.1.13 *test start, n*—introduction of test oil into the engine. **D 5533**

3.2 Definitions of Terms Specific to This Standard:

3.2.1 *aged test oil, n*—an engine oil to be tested that has been previously subjected to use in a spark-ignited operating engine for a prescribed length of service under prescribed conditions.

3.2.2 *aging, n*—the subjecting of an engine oil to use in a spark-ignited operating engine for a prescribed length of service under prescribed conditions.

3.2.3 *break-in, v*—in internal combustion engines, the running of a new engine under prescribed conditions to help stabilize engine response and help remove initial friction characteristics associated with new engine parts.

3.2.4 *central parts distributor (CPD), n*—the manufacturer or supplier, or both, of many of the parts and fixtures used in this test method.

3.2.4.1 *Discussion*—Because of the need for availability, rigorous inspection, and control of many of the parts used in this test method, companies having the capabilities to provide the needed services have been selected as the official suppliers for the Sequence VIB test method. These companies work closely with the Test Procedure Developer, and with the ASTM groups associated with the test method to help ensure that the critical engine parts used in this test method are available to the testing industry and function satisfactorily.

3.2.5 *flush, v*—to wash out with a rush of engine oil, during a prescribed mode of engine operation to minimize carryover effect from the previous oil and remove residues, before introducing a new test oil.

3.2.6 *flying flush, n*—in internal combustion engines, the washing out with a rush of engine oil, during a prescribed mode of engine operation to minimize carryover effect from the previously used oil and remove residues without stopping the engine after the previous test.

3.2.7 *fuel economy, n*—in internal combustion engines, the efficient use of gasoline.

3.2.7.1 *Discussion*—Determined by comparing the rate of fuel consumption of a test oil with that displayed by a base line reference oil.

3.2.8 *non-standard test, n*—a test conducted with operating conditions (that is, engine speeds, loads, temperatures, and so forth) outside the normal test operating conditions or with a fuel other than the specified test fuel or with non specified hardware configuration.

3.2.9 *special parts distributor (SPD), n*—the manufacturer or supplier, or both, of specified parts and fixtures used in this test method.

3.2.10 *special test parts (STP), n*—parts that do not meet all the definitions of critical parts or non-production parts, but shall be obtained from the SPD.

4. Summary of Test Method

4.1 The 4.6-L internal combustion engine is installed on a dynamometer test stand equipped with the appropriate controls for speed, load, and various other operating parameters.

4.2 The test method consists of measuring the laboratory engine brake specific fuel consumption at five constant speed/load/temperature conditions for the baseline calibration oil, test oil, and a repeat of the baseline calibration oil. The approximate test length is 133 h.

4.3 Aged test oil is compared directly to fresh ASTM BC SAE 5W-30 (see X1.2) baseline calibration oil, which is run before and after the test oil. When changing from test oil to baseline calibration oil, an intermediate flush with a special flushing oil (BC Flush Oil or BCFHD) is required to minimize the possibility of a carryover effect from the previous oil.

4.4 Test results are expressed as a percent change in weighted fuel consumption (see Table 6) relative to the baseline calibration oil.

5. Significance and Use

5.1 *Test Method*—The data obtained from the use of this test method provide a comparative index of the fuel-saving capabilities of automotive engine oils under repeatable laboratory conditions. A baseline calibration oil (hereafter referred to as BC oil) has been established for this test to provide a standard against which all other oils can be compared. The BC oil is an SAE 5W-30 grade fully-formulated lubricant. There is a direct correlation of Test Method D 6837 (Sequence VIB) Fuel Economy Improvement (FEI) by percent with the fuel economy results obtained from vehicles representative of current production running under the current EPA testing cycles. The test procedure was not designed to give a precise estimate of the difference between two test oils without

TABLE 1 Sequence VIB Fuel Specification

	Test Method	
Octane, research min	D 2699	96
Pb (organic), mg/L max	D 3237	13.2 (0.05 g/U.S.gal)
Sensitivity, min		7.5
Distillation range		
IBP, °C	D 86	23.9 to 35 (75 to 95°F)
10 % point, °C	D 86	48.9 to 57.2 (120 to 135°F)
50 % point, °C	D 86	93.3 to 110 (200 to 230°F)
90 % point, °C	D 86	148.9 to 162.8 (300 to 325 °F)
E.P., °C (max)	D 86	212.8 (415°F)
Sulfur, weight %, max	D 4294	0.10
Phosphorous, mg/L, max	D 3231	1.32 (0.005 g/U.S.gal)
RVP, kPa	D 323	60.0 to 63.4 (8.7 to 9.2 psig)
Hydrocarbon composition		
Olefins, % max	D 1319	10
Aromatics, % max	D 1319	35
Saturates	D 1319	Remainder
Existent gum, mg/100mL, max	D 381	5.0
Oxidation stability, min	D 525	500
Carbon weight fraction	E 191	Report
Hydrogen/Carbon ratio, mol basis	E 191	Report
Net heating value, Btu/lb	D 240	Report
Net heating value, Btu/lb	D 3338	Report
API gravity	D 287	Report

TABLE 2 Sequence VIB New Engine Cyclic Break-in^A

	Cycle	
	A	B
Time at Each Step, min	4	1
Time to Decel. to Step A, s		15 max
Time to Accel. to Step B, s	15 max	
Speed, r/min	1500	3500
Power, kW (hp)	7.5 (10.1)	20.9 (28)
Load, N·m (lb-ft)	48.00 (35.4)	57.00 (42.04)
Oil Gallery, °C (°F)	105 (221)	105 (221)
Coolant In, °C (°F)	95 (203)	95 (203)
Coolant Flow, L/min (gal/min)	130 (34.3)	130 (34.3)
Intake Air temperature. and Humidity	Control Not Required	
Ignition Timing, °BTDC	Record	Not Specified
Exh. Back Press., kPa (in. Hg, abs)	104.0 (30.80)	Not Specified
AFR	Record	Not Specified
Fuel Pressure to Fuel Rail, kPa (psi)	205 to 310 (30 to 45)	205 to 310 (30 to 45)
Fuel Temperature to Fuel Rail, °C (°F)	20 (68)	20 (68)
Fuel Flow, kg/h (lb/h)	Not Specified	Not Specified
BSFC, kg/kW·h (lb/hp·h)	Not Specified	Not Specified

^A The time at each cycle and their acceleration and deceleration times shall be adhered to; target all other parameters as close as possible.

adequate replication. Rather, it was developed to compare a test oil to BC oil. Companion test methods used to evaluate engine oil performance for specification requirements are discussed in the latest revision of Specification D 4485.

5.2 *Use*—The Sequence VIB test method is useful for engine oil fuel economy specification acceptance. It is used in specifications and classifications of engine lubricating oils, such as the following:

- 5.2.1 Specification D 4485.
- 5.2.2 API Publication 1509.
- 5.2.3 SAE Classification J304.
- 5.2.4 SAE Classification J1423.

6. Apparatus

6.1 *General*—Standardize certain aspects of each test stand in terms of stand hardware. Examples of components which are specified are certain pumps, valves, heat exchangers, heaters, and piping nominal inside diameter (I.D.). Where specified, four classes or categories of stand hardware have been designated:

6.1.1 Prints for special parts are included in this procedure. When using these prints to fabricate special parts, use the dimensions specified for the various parts. Do not scale off the drawings or use them as a pattern. Use all equipment specified in the procedure. Substitution of equivalent equipment is allowed, but only after equivalency has been proven acceptable by the Sequence VIB Surveillance Panel.

6.2 *Test Engine Configuration*—The test engine is a specially built 1993 4.6-L Ford V-8 engine⁸ designed for use with an Automatic Overdrive Electronic (AODE) transmission (see X1.3 for procurement of this engine). Mount the engine on the test stand so that the flywheel friction face is $3.6 \pm 0.5^\circ$ from the vertical with the front of the engine higher than the rear.

The U-joint angles shall not be greater than 2.0° in the vertical plane and 0.0° in the horizontal.

6.3 *Laboratory Ambient Conditions*—Do not permit air from fans or ventilation systems to blow directly on the engine. The ambient laboratory atmosphere shall be relatively free of dirt, dust, or other contaminants as required by good laboratory standards.

6.4 *Engine Speed and Load Control*—The dynamometer speed and load control systems shall be capable of maintaining the limits specified in Tables 2-4. A typical closed-loop control system maintains speed by engine throttle control and load by dynamometer control. Since these speed and load tolerances require sensitive and precise control, give particular attention to achieving and maintaining accurate calibration of the related instrument systems.

6.4.1 *Dynamometer*—Use a Midwest or Eaton 37 kW (50-hp) Model 758 dry gap dynamometer (see X1.4). Replacing an engine dynamometer during a reference or non-reference test is not acceptable. If a dynamometer needs to be replaced during a test, abort the test. Calibrate the new dynamometer and related instrumentation before starting a new test.

6.4.2 *Dynamometer Load:*

6.4.2.1 *Dynamometer Load Cell*—Measure the dynamometer load by a 0 to 45 kg (0 to 100 lb) load cell. The dyno load cell is required to have the following features:

(1) Good temperature stability:

Zero $\leq 0.001\%$ FSO (Full Scale Output) per °C (0.002 % FSO per °F), and

Span $\leq 0.001\%$ FSO per °C (0.002 % FSO per °F).

(2) Nonlinearity $\leq 0.05\%$ FSO.

(3) Temperature compensation over range expected in laboratory (10 to 49°C) (50 to 115°F). A Lebow Model 3397 load cell (see X1.5) has been found suitable for this application.

6.4.2.2 *Dynamometer Load Cell Damper*—Do not use a load cell damper.

6.4.2.3 *Dynamometer Load Cell Temperature Control*—Control the load cell temperature. Enclose the dynamometer load cell to protect it from the variability of laboratory ambient temperatures. Maintain air in the enclosure within the operating temperature range specified by the load cell manufacturer within a variability of no more than $\pm 6^\circ\text{C}$ ($\pm 10.8^\circ\text{F}$). Control temperature by a means that does not cause uneven temperatures on the body of the load cell.

6.4.2.4 *Dynamometer Connection to Engine*—Use U-joints for the dynamometer-to-engine connection (see 6.2).

6.5 *Engine Cooling System*—An external engine cooling system, as shown in Figs. A2.1-A2.5, is required to maintain the specified jacket coolant temperature and flow rate during the test. An alternative cooling system is shown in Fig. A2.3. The systems shall have the following features:

6.5.1 Pressurize the coolant system at the top of the reservoir. Control the system pressure to 69 ± 13.8 kPa (10 ± 2 psi). Install a pressure cap (PC-1 in Figs. A2.1-A2.3) (see X1.6) capable of maintaining system pressure within the above requirements.

⁸ A specially built 1993 4.6L Ford V-8 internal combustion engine is a product of Ford Motor Co., Dearborn, MI 48121. It is available as Part No. R2G-800-XB (AOD-E) from AER, 1605 Surveyor Blvd., P.O. Box 979, Carrollton, TX 75011-0979.

TABLE 3 Sequence VIB Test Operating Conditions^A

Parameter	Stage 1	Stage 2	Stage 3	Stage 4	Stage 5
Speed, r/min ^B	1500 ±2	800 ±2	800 ±2	1500 ±2	1500 ±2
Load, Nm ^B	98.00 ±0.07	26.00 ±0.07	26.00 ±0.07	98.00 ±0.07	98.00 ±0.07
Nominal, Power kW	15.39	2.18	2.18	15.39	15.39
Gallery, °C ^B	125 ± 1	105 ± 1	70 ± 1	70 ± 1	45 ± 1
Coolant, °C ^B	105 ± 1	95 ± 1	60 ± 1	60 ± 1	45 ± 1
Stabilization Time, min ^C	60	60	60	60	60
All Stages					
Temperatures, °C					
Oil Circulation			Record		
Coolant Out			Record		
Intake Air ^B			27 ± 2		
Fuel-to-Flowmeter ^D			20 to 32 (delta from the max stage average reading shall be ≤4)		
Fuel-to-Fuel Rail ^B			20 ± 2		
Delta Load Cell ^D			Delta from the max stage average shall be ≤6		
Oil Heater			205 max		
Pressures					
Intake Air, kPa			0.05 ± 0.02		
Fuel-to-Flowmeter, kPa			100 min		
Fuel-to-Fuel Rail, kPa			205 to 310		
Intake Manifold, kPa abs.			Record		
Exhaust Back Pressure, kPa abs. ^B			104.00 ± 0.17		
Engine Oil, kPa			Record		
Crankcase, kPa			0.0 ± 0.25		
Flows					
Engine Coolant, L/min			130 ± 4		
Fuel Flow, kg/h ^B			Record		
Humidity, Intake Air, gr/kg of dry air			11.4 ± 0.8		
Air-to-Fuel Ratio ^B			14.00:1 to 15.00:1		
Air-to-Fuel Ratio ^D			Delta from max stage average reading shall be ≤0.50		
Ignition Timing			20° BTDC ± 2°		

^A Controlled parameters should be targeted for the middle of the specification range.

^B Critical measurement and control parameters.

^C Counted from the time the temperature set points are initially adjusted to the specific levels.

^D Difference between the maximum stage average reading of the entire test and the individual stage average readings.

6.5.2 The pumping system shall be capable of producing 130 ± 4 L/min (34.3 ± 1.1 gal/min). A Goulds G&L centrifugal pump (P-1 in Figs. A2.1-A2.3), Model NPE, Size 1ST, mechanical seal, with a 2-hp, 3450-r/min motor, is specified (see X1.7). Voltage and phase of the motor is optional.

6.5.3 The coolant system volume is not specified, however certain cooling system components are specified as shown in Figs. A2.1-A2.5. Adhere to the nominal I.D. of the line sizes as shown in Figs. A2.2-A2.5.

6.5.4 The specified heat exchanger (HX-1 in Figs. A2.1-A2.3) is an ITT Standard brazed plate model 320-20, Part No. 5-686-06-020-001 or ITT Bell and Gossett brazed plate model BP-75H-20, Part No. 5-686-06-020-001 (see X1.8). Parallel or counterflow through the heat exchanger is permitted.

6.5.4.1 Approved replacement heat exchangers are: ITT Bell and Gossett brazed plate Model BP-420-20, Part No. 5-686-06-020-005 and ITT Bell and Gossett brazed plate Model BP-422-20, Part No. 5-686-06-020-007.

6.5.4.2 The specified heat exchanger for the alternative cooling system (see Fig. A2.3) is an ITT shell and tube Model BGF 5-030-06-048-001.

6.5.5 An orifice plate (OP-1 in Figs. A2.1-A2.5) is specified. It is recommended that the orifice plate be sized to provide a pressure drop equal to that of heat exchanger HX-1 and install it in the bypass loop of the coolant system.

6.5.5.1 An orifice plate (OP-1) is not required when using the alternative cooling system (see Fig. A2.3).

6.5.6 An orifice plate (differential pressure) (FE-103 in Figs. A2.1-A2.5) is specified (see X1.9). This orifice plate is a Daniel Series No. 30 RT threaded orifice flange, 1½ NPT. Size this orifice plate to yield a pressure drop of 11.21 ± 0.50 kPa (45.0 ± 2.0 in. H₂O) at a flow rate of 130 L/min (34.3 gal/min). There shall be 10 diameters upstream and 5 diameters downstream of straight, smooth pipe with no reducers or increasers. Flange size shall be the same size as pipe size. Threaded, slip-on or weld neck styles can be used as long as a consistent pipe diameter is kept throughout the required lengths.

6.5.7 A control valve (TCV-104 in Figs. A2.1-A2.4) is required for controlling the engine coolant flow rate through the heat exchanger HX-1 and the heat exchanger bypass portion of the cooling system.

6.5.7.1 A Badger Meter Inc. Model No. 9003TCW36SV3AxxL36 (air-to-close), or Model No. 9003TCW36SV1AxxL36 (air-to-open) 3-way globe (divert), 2-in. valve is the specified valve (see X1.10).

6.5.7.2 A Badger Meter Inc. Model No. 9003TCW36SV3A29L36 (air-to-close), or Model No. 9003TCW36SV1A29L36 (air-to-open) are also acceptable if the trim package used with these valves has a CV of 16.0.

6.5.7.3 Install the valve in a manner so that loss of air pressure to the controller results in coolant flow through the

TABLE 4 Sequence VIB Test Operating Conditions^A Stage Flush and Stage Aging Hours SI Units

	Stage Flush	Aging Phase I	Aging Phase II
Speed, r/min	1500 ± 5	1500 ± 5	2250 ± 5
Load, Nm	98.00 ± 0.10	98.00 ± 0.10	98.00 ± 0.10
Temperatures, °C ^B			
Oil Gallery	125 ± 2	125 ± 2	135 ± 2
Coolant In	105 ± 2	105 ± 2	105 ± 2
Oil Circulation	Record	Record	Record
Coolant Out	Record	Record	Record
Intake Air	27 ± 2	27 ± 2	27 ± 2
Fuel-to-Flowmeter ^C	20 to 32	20 to 32	20 to 32
Fuel-to-Rail	20 ± 2	20 ± 2	20 ± 2
Pressures			
Intake Air, kPa	0.05 ± .02	0.05 ± 0.02	0.05 ± 0.02
Fuel-to-Flowmeter, kPa	100 min	100 min	100 min
Fuel-to-Rail, kPa	205 to 310	205 to 310	205 to 310
Intake Manifold, kPa abs	Record	Record	Record
Exhaust Back, kPa abs	104.00 ± 0.20	104.00 ± 0.20	104.00 ± 0.20
Engine Oil, kPa	Record	Record	Record
Flows and Others			
Engine Coolant, L/min	130 ± 4	130 ± 4	130 ± 4
Fuel Flow, kg/h	Record	Record	Record
Humidity, Intake Air	Record	Record	Record
gr/kg, of dry air	11.4 ± 0.8	11.4 ± 0.8	11.4 ± 0.8
Air-to-Fuel Ratio	14.00:1 to 15.00:1	14.00:1 to 15.00:1	14.00:1 to 15.00:1
Ignition Timing, °BTDC	20 ± 2°	20 ± 2°	20 ± 2°
Crankcase, Pressure, kPa	N/A	0.0 ± 0.25	0.0 ± 0.25

^A Controlled parameters should be targeted for the middle of the specification range.

^B Counted from the time the temperature set points are initially adjusted to the specific levels.

^C ±3°C within this range.

heat exchanger rather than through the coolant bypass (fail safe). Air-to-open/air-to-close is optional.

6.5.7.4 Control valve (TCV104) is not required when using the alternative cooling system (see Fig. A2.3).

6.5.8 A control valve (FCV-103 in Figs. A2.1-A2.5) is required for controlling the coolant flow rate to 130.0 ± 4 L/min (35 ± 1 gal/min). A Badger Meter Inc. Model No. 9003GCW36SV3A29L36, 2-way globe, 2-in., air-to-close valve is the specified valve (see X1.10).

6.5.9 A Viatran model 274/374, Validyne model DP15, or Rosemount model 1151 differential pressure transducer (DPT-1 in Fig. A2.5) is required for reading the coolant flow rate at the orifice plate (FE-103 in Figs. A2.1-A2.3) (see X1.11).

6.5.10 Either replace the engine water pump with a water pump plate as shown in Fig. A2.6 or modify the pump by removing the impeller and welding a block off plate onto the front of the pump or tapping the front of the pump and screwing in a pipe plug. The water pump plate can be fabricated by the laboratory or procured as Part No. OHT6A-014-A (see X1.12).

6.5.11 A coolant reservoir, a coolant overflow container, and a sight glass are required as shown in Figs. A2.1-A2.3, and Fig. A2.5. The design or model of these items is optional.

6.5.12 A control valve (TCV-101 in Fig. A2.1 and Fig. A2.4) is required for controlling the process water flow rate through the heat exchanger HX-1. A Badger Meter Inc. Model 9001GCW36SV3Axxx36 (air-to-close) or Model 9001GCW36SV1Axxx36 (air-to-open), 2-way globe, 1-in.

valve is the specified valve (see X1.10). The type of trim package that may be used with this valve is optional.

6.5.13 A 1½-in. NPT sight glass is required in the main coolant circuit (SG-1 in Figs. A2.1-A2.3, and Fig. A2.5). The make/model is optional.

6.5.14 Brass, copper, or stainless steel materials are recommended for hard plumbing in the coolant system.

6.5.15 The materials used for process water, hot water, chilled water, process air, engine coolant overflow, and engine coolant transducer tubing are at the discretion of the laboratory.

6.5.16 The system shall have provisions (for example, low point drains) for draining all of the flushing water prior to installing a new coolant mixture.

6.6 *External Oil System*—An external oil system as shown in Figs. A2.7 and A2.8 is required. Although all of the systems are interconnected in some manner, the overall external oil system is comprised of two separate circuits: (1) the flying flush system which allows the oil to be changed while the engine is running, and (2) the circulation system for oil temperature control. The engine oil pan is considered a part of the external oil system. Minimize the external oil volume of all of the circuits as well as the length of connections and surfaces in contact with more than one oil in the flush system to enable more thorough flying flushes.

6.6.1 The flush system has a high capacity scavenge pump which fills a 6.0-L (6.34-qt) dump reservoir while fresh oil is drawn into the engine. The dump reservoir float switch then resets certain solenoids and the engine refills to the level established by the float switch in the engine oil pan (which then closes the solenoid to the fresh oil reservoir).

6.6.2 The oil heat/cool loop uses a proportional controller to bypass the cooling heat exchanger. Control the temperature within narrow limits with minimal additional heat (and surface temperatures). The system can respond quickly to establish the four different oil gallery temperatures required in the procedure. Arrange the proportional three-way control valve to go to its mid-point during the flying flushes to avoid trapping oil, and there shall be some cooling during test oil aging so that no oil is trapped in the cooler.

6.6.3 Cuprous materials are not allowed in any of the oil system (excluding the oil scavenge discharge system) except as may be required by the use of mandatory equipment in this procedure.

6.6.4 The flying flush system (see Fig. A2.7) shall have the following features:

NOTE 1—The items shown in the clouded areas in Fig. A2.7 are not specifically required. However, a system that performs these functions is required.

6.6.4.1 A scavenge pump (P-3 in Figs. A2.7 and A2.8). A Viking Series 475, gear type, close-coupled pump, model H475M is specified (see X1.13). The pump shall have an 1140 to 1150-r/min electric motor drive with a minimum of 0.75 hp. Voltage and phase are optional.

6.6.4.2 A reservoir with a minimum capacity of 19 L (5 gal). It is recommended that the system include three reservoirs (one for BC calibration oil, one for BCFHD flush oil, and one for test oil).

6.6.4.3 An oil stirrer in each oil reservoir.

TABLE 5 Test Schedule

		Estimated Elapsed Time, h ^A
BC Oil Test		
1.	Double flush to BC	1:30
2.	S60, BSFC/fuel flow × 6 at Stage 1 ^B	1:30
3.	S60, BSFC/fuel flow × 6 at Stage 2	1:30
4.	S60, BSFC/fuel flow × 6 at Stage 3	1:30
5.	S60, BSFC/fuel flow × 6 at Stage 4	1:30
6.	S60, BSFC/fuel flow × 6 at Stage 5	1:30
7.	Warm-up to Stage Flush	0:30
	Subtotal	9:30
Test Oil Test		
1.	Double flush to test oil	1:00
2.	Age 16 h at Stage Age Phase I	16:00
3.	S60, BSFC/fuel flow × 6 at Stage 1	1:30
4.	S60, BSFC/fuel flow × 6 at Stage 2	1:30
5.	S60, BSFC/fuel flow × 6 at Stage 3	1:30
6.	S60, BSFC/fuel flow × 6 at Stage 4	1:30
7.	S60, BSFC/fuel flow × 6 at Stage 5	1:30
8.	Age 80 h at Stage Age Phase II	80:00
9.	S60, BSFC/fuel flow × 6 at Stage 1	1:30
10.	S60, BSFC/fuel flow × 6 at Stage 2	1:30
11.	S60, BSFC/fuel flow × 6 at Stage 3	1:30
12.	S60, BSFC/fuel flow × 6 at Stage 4	1:30
13.	S60, BSFC/fuel flow × 6 at Stage 5	1:30
14.	Warm-up to Stage Flush	0:30
	Subtotal	112:30
BC Oil Test		
1.	Detergent flush to BC	3:30
2.	S60, BSFC/fuel flow × 6 at Stage 1	1:30
3.	S60, BSFC/fuel flow × 6 at Stage 2	1:30
4.	S60, BSFC/fuel flow × 6 at Stage 3	1:30
5.	S60, BSFC/fuel flow × 6 at Stage 4	1:30
6.	S60, BSFC/fuel flow × 6 at Stage 5	1:30
	Subtotal	11:00
End of Test Shutdown	Overall Total	133:00

^A Adhere to stabilization times and times for the 6 replicate BSFC measurements. Warm-up and cool-down times included in flushing elapsed times are estimates.

^B Example: Stabilize 60 min followed by 6 replicate BSFC measurements at 5 min intervals (3 min for set-up, 2 min for time averaged BSFC with Stage 1 operating conditions).

6.6.4.4 An oil heating system (with appropriate controls) for each oil reservoir with the capability of heating the oil in the reservoir to $107 \pm 2.8^\circ\text{C}$ ($224.6 \pm 5^\circ\text{F}$).

6.6.4.5 A dump reservoir (see Figs. A2.7-A2.9) with a minimum 6 L (6.34 qt) capacity.

6.6.4.6 A dump reservoir float switch is required. (FLS-136 in Figs. A2.7-A2.9) The make and model is optional. A Gems Series ALS79999, Catalog No. A79999, 20 VA, high temperature float switch has been found suitable for this application (see X1.14).

6.6.4.7 Adhere to the nominal I.D. line sizes shown in Fig. A2.8.

6.6.5 The circulation system for oil temperature control shall have the following features:

6.6.5.1 A total volume, including oil volume in the oil pan to the full mark, shall be 6.0 L (6.34 qt). See 6.6.5.16.

6.6.5.2 An engine oil pan float switch (FLS-152 in Fig. A2.7, Fig. A2.10, and Fig. A2.16) is required. A Gems Series ALS79999, Catalog No. A79999, 20 VA, high temperature float switch is specified (see X1.14).

6.6.5.3 A positive displacement oil circulation pump (P-4 in Fig. A2.7) is required. A Viking Series 4125, Model G4125, no relief valve, base mounted is specified (see X1.15). The pump

shall have a V-belt or direct drive 1140 to 1150-r/min electric drive motor with a minimum of 0.56 Kw (0.75 hp). Voltage and phase are optional.

NOTE 2—The explosion proof requirement for the motor is left to the discretion of the laboratory.

NOTE 3—Either V-belt drive or direct-coupled drive may be used. If V-belt drive is used, use a 1:1 pulley ratio so that the final speed of the pump is a nominal 1150 r/min.

6.6.5.4 Solenoid valves (FCV-150A, FCV-150C, FCV-150D, and FCV-150E, in Figs. A2.7 and A2.8) are required (see X1.16).

(1) FCV-150F and its related lines/piping are optional.

(2) FCV-150A is a Burkert Type 251 piston-operated valve used with a Type 312 solenoid valve (or a Burkert Type 2000 piston-operated valve used with a Type 311 or 330 solenoid valve) for actuation of air supply to the piston valve, solenoid valve direct-coupled to piston valve, normally closed, explosion proof (left to the discretion of the laboratory), and watertight, $\frac{3}{4}$ in., 2-way, stainless steel.

(3) FCV-150C is a Burkert Type 251 piston-operated valve used with a Type 312 solenoid valve (or a Burkert Type 2000 piston-operated valve used with a Type 311 or 330 solenoid valve) for actuation of air supply to the piston valve, solenoid

TABLE 6 Calculation of Test Results

Test Stage	Nominal Speed, r/min	Nominal Power, kW	Time Wt. Factor, h
1	1500	15.39	0.0802
2	800	2.18	0.0787
3	800	2.18	0.0848
4	1500	15.39	0.0864
5	1500	15.39	0.0699

NOTE 1—For Stage 1, steps 1 through 6 round and record the 5-min BSFC measurements to 4 decimal places using ASTM rounding.

NOTE 2—Average the BSFC measurements of the six steps to 5 decimal places using ASTM rounding. Units for BSFC are kg/kW-h.

NOTE 3—Multiply the average by the shown nominal power and time factor for Stage 1 and record the answer to 6 decimal places. The unit for this number is kg of fuel consumed.

NOTE 4—Perform calculation steps 1, 2, and 3 for the remaining test stages (2 to 5) using the respective nominal power and time factors.

NOTE 5—Total the mass fuel consumption values for all 5 stages.

NOTE 6—Complete the total fuel consumed calculation detailed in Steps 1 to 5 above for the BC Before Test Oil, Test Oil Phase I, Test Oil Phase II, and BC After Test Oil.

NOTE 7—Compute the test oil fuel economy improvement (FEI) as follows:

$$\% \text{ FEI Test Oil Phase I} = \left\{ \left[\frac{(\text{BC Before} \times 80\%) + (\text{BC After} \times 20\%) - \text{Test Oil}}{(\text{BC Before} \times 80\%) + (\text{BC After} \times 20\%)} \right] \right\} \times 100$$

$$\% \text{ FEI Test Oil Phase II} = \left\{ \left[\frac{(\text{BC Before} \times 10\%) + (\text{BC After} \times 90\%) - \text{Test Oil}}{(\text{BC Before} \times 10\%) + (\text{BC After} \times 90\%)} \right] \right\} \times 100$$

NOTE 8—Adjust the FEI result(s) on non-reference oil tests for the stand/engine severity in accordance with Annex A7.

TABLE 7 Calculation of BSFC

1W = 1N·m/s
 1kW = 1000 N·m/s
 1kW = 60 000 N·m/min
 1kW = 2π T N/60 000
 1kW = T N/9549.3

Example:

Speed = 800 r/min
 Torque = 19.18 lbf·ft = 26.004 N·m
 hp = T N/5252 = (800 × 19.18)/5252 = 2.92
 kW = T N/9549.3 = (800 × 26.004)/9549.3 = 2.1785052
 2.1785052 kW/746 = 2.92 hp

In SI Units:

BSFC = (fuel flow, kg/h)/(9549.3)/(speed, r/min) (Torque, N·m)

In Inch-Pound Units:

BSFC = (fuel flow, lb/h)/(5252)/(speed, r/min) (Torque, lbf·ft)

valve direct-coupled to the piston valve, normally open, explosion proof (left to the discretion of the laboratory) and watertight, ½ in., 2-way, stainless steel.

(4) FCV-150D, FCV-150E, and FCV-150F are Burkert Type 251 piston-operated valves used with a Type 312 solenoid valve (or a Burkert Type 2000 piston-operated valve used with a Type 311 or 330 solenoid valve) for actuation of air supply to the piston valve, solenoid valve direct-coupled to the piston valve, normally closed, explosion proof (left to the discretion of the laboratory), and watertight, ½ in., 2-way, stainless steel.

(5) Use only one type of Burkert piston and solenoid valve on a test stand.

6.6.5.5 Control valve (TCV-144 in Figs. A2.7 and A2.8) is required. The specified valve is a Badger Meter Inc. Model No. 1002TBN36SVOSALN36, 3-way globe (divert), ½-in., air to open valve (see X1.17).

6.6.5.6 Control valve (TCV-145 in Figs. A2.7 and A2.8) is optional (see X1.17).

6.6.5.7 A heat exchanger (HX-6 in Figs. A2.7 and A2.8) is required for oil cooling. The specified heat exchanger is an ITT model 310-20 or a ITT Bell & Gossett, model BP-25-20 (Part No. 5-686-04-020-001), brazed plate (see X1.18).

NOTE 4—The ITT Standard and ITT Bell and Gossett heat exchangers have been standardized under one model and part number. The new replacement is Model BP410-20, Part No. 5-686-04-020-002.

6.6.5.8 An electric heater (EH-5 in Figs. A2.7 and A2.8) is required for oil heating. The specified heater is a heating element inserted in the liquid Cerrobace inside a Labeco oil heater housing (see X1.19). Any 3000 W heater element may be used within the Labeco housing. There are two recommended heating elements: (1) a three element with Incaloy sheath, Chromolox Part No. GIC-MTT-330XX, 230 V, single phase, and (2) Wiegand Industries/Chromolox, Emerson Electric Model MTS-230A, Part No. 156-019136-014, 240 V single phase.

(1) It is specified that a thermocouple be installed in the external oil heater so that the temperature can be monitored. Install this thermocouple into the top of the heater into the Cerrobace (see Fig. A2.14) to an insertion depth of 244.48 ± 3.18 mm (9.625 ± 0.125 in.). Do not exceed the maximum temperature of 205°C (401°F).

(2) The procedure for replacing a heating element is detailed in Annex A3.

6.6.5.9 Install two oil filters (FIL-2 in Figs. A2.7 and A2.8) in the external oil system. The filters specified are Oberg or Racor model LFS-55 with an Oberg or Racor 28 mm stainless steel screen, Part No. LFS 5528 (see X1.20).

(1) An alternative oil filter model LFS-62 with an Oberg or Racor 28 mm stainless steel screen, Part No. LFS 5528 (see X1.20), may be used.

(2) Both oil filters in the test stand shall have the same model number.

(3) Locate one filter anywhere in the external oil system after the oil circulation pump, and locate the other between the engine oil pump and where the oil enters the engine oil gallery.

(4) When replacing the test stand's oil filters to the alternative model LFE-62, do so immediately prior to a calibration test.

6.6.5.10 Adhere to the nominal piping I.D. sizing shown in Fig. A2.8.

6.6.5.11 Use modified oil filter adapter assembly, Part No. OHT6A-007-1 (see X1.21), as shown in Fig. A2.15.

6.6.5.12 Engine oil plumbing shall be stainless steel tubing or piping or flexible hose suitable for use with oils at the temperatures specified. Where flexible hose is used in the external oil system, excluding the line to the dump tank, use either Aeroquip No. 8 (Part No. 2807-8) or Aeroquip No. 10 (Part No. 2807-10) (see X1.22).

6.6.5.13 Insulation of plumbing for the external oil circulation system is mandatory. Insulation material selection is optional but shall have a maximum thermal conductivity of 0.0398 W/(m·K) at a mean temperature of 32.2°C (0.276 Btu-in./h·ft²·°F at a mean temperature of 90°F).

6.6.5.14 *Engine Oil Pan*—Oil pan (Ford Part No. F1AZ-6675-A or F2AZ-6675-A) is required. A modified oil pan may be fabricated by the laboratory or procured as Part No. OHT6A-006-1 (see X1.23). Remove all stock baffles from the pan. An oil pan baffle as shown in Fig. A2.12 is required and installed as shown in Figs. A2.10 and A2.11. These two figures also show the oil pan connections for connecting to the external oil system. Installation of viewing windows are optional as shown in Figs. A2.10 and A2.11. Install a float switch (FLS-152 in Fig. A2.7 and Fig. A2.16, Gems Series ALS79999, Catalog No. 79999) (see X1.14) in the oil pan. The float switch may be mounted from the pan bottom as shown in Fig. A2.10 or from an adjustable rod through the dipstick hole.

(1) *Oil Pan Baffle*—Figs. A2.10 and A2.11 illustrate a side view of the oil pan and the position of the baffle on the left inside wall of the pan. Bend the ears on each end of the baffle about 45° toward the wall of the pan. Fit the top edge of the baffle tight against the wall and incline downward toward the front of the engine approximately 23°, with respect to the pan rail. When the baffle is tack-welded in this position the opening at the bottom of the baffle will divert the incoming stream of oil downward and a little toward the back of the pan.

6.6.5.15 *Oil Pump Screen and Pickup Tube*:

(1) Cut off the steel engine oil pickup tube immediately above the oil screen and weld a 15 to 18 cm (6 to 7 in.) long straight stainless steel tube of the same inside and outside diameters as the original tube to the end so it will project down through the fitting in the bottom of the pan. The pick up tube can be modified by the laboratory or procured as Part No. OHT6A-008-1 (see X1.23). Make the fitting in the bottom of the pan from a Swagelok SS-1210-1-8, 3/4-in. compression × 1/2-in. NPT fitting. Cut the NPT end off and weld remaining part to the underside outside bottom of the oil pan. There will then be an inside shoulder in the fitting to drill out for the 3/4-in. outside diameter (O.D.) tube to pass through (see Figs. A2.10 and A2.11).

(2) Use the double nylon ferrules (Part No. T-1213-1 and T-1214-1) to seal against the steel tube rather than metal ones to avoid crimping the wall of the tube (which can make it difficult to reseal after removing the oil pan).

(3) After the oil pan is installed on the engine and the use of a compression fitting is arranged to connect the tube to an external oil hose, the suction tube may be shortened if necessary.

6.6.5.16 *Engine Oil Level Control*—Install a sight glass tube, as shown in Fig. A2.24, as a provision for monitoring the oil level and determining oil consumption. See Annex A9 for instructions on oil consumption measurement/calibration.

6.7 *Fuel System*—A typical fuel delivery system incorporating all of the required features is shown in Fig. A2.17. The fuel system shall include provisions for measuring and con-

trolling fuel temperature and pressure into the fuel flow measuring equipment and into the engine fuel rail.

6.7.1 There shall be a minimum of 10 cm (3.9 in.) of flexible line at the inlet and outlet of the fuel flow meter (rubber/synthetic suitable for use with gasoline). Compression fittings are allowed for connecting the flexible lines to the fuel flow meter. Fuel supply lines from the fuel flow measurement equipment to the engine fuel rail shall be stainless steel tubing or piping or any flexible hose suitable for use with gasoline. The fuel return line from the engine shall have a minimum I.D. of 6.35 mm (0.25 in.).

6.7.2 *Fuel Flow Measurement*—Fuel flow rate measurement is critical and is measured throughout the test. A Micro Motion Model D-6 mass flow meter with an RFT9712 Smart Family or RFT9739 transmitter or a Model CMF010 mass flow meter with an RFT9739 transmitter is specified (see X1.24). The Micro Motion sensor may be mounted in a vertical or a horizontal position.

6.7.2.1 Fuel flow measurement is coordinated to allow a meaningful calculation of brake specific fuel consumption in kg/kW-h (lb/hp-h). Specifically, speed, load, fuel flow, and AFR are time-averaged over the same 100 to 120-s interval. The use of frequency output from the fuel flow meter is recommended to avoid electrical noise affecting analog signal output.

6.7.3 *Fuel Temperature and Pressure Control to the Fuel Flow Meter*—Maintain fuel temperature and pressure to the fuel flow meter at the values specified in Tables 2-4. Precise fuel pressure control without fluctuation or aeration is mandatory for test precision. The fuel pressure regulator PRG 116 shall have a safety pressure relief, or a pressure relief valve, PRV 113, parallel to PRG 116 for safety purposes.

6.7.4 *Fuel Temperature and Pressure Control to Engine Fuel Rail*—Maintain fuel temperature and pressure to the engine fuel rail at the values specified in Tables 2-4. Precise fuel temperature and precise fuel pressure control without fluctuation or aeration is mandatory for test precision.

6.7.5 *Fuel Supply Pumps*—The test method of providing fuel to the fuel flow meter is at the laboratory's discretion as long as the requirements for fuel pressure and temperature are met. For providing fuel from the fuel flow meter to the engine fuel rail, use a car type fuel pump, Ford Part No. E7TF-9C407 or E7TC-9C407. The minimum fuel pressure is 205 kPa (30 psig) and the maximum is 310 kPa (45 psig). Purchase this part from the CPD (see X1.38).

6.7.6 *Fuel Filtering*—Filtering of the fuel supplied to the test stand is required in order to minimize fuel injector difficulties.

6.8 *Engine Intake Air Supply*—Suitable apparatus is required to deliver approximately 4.0 m³/min (140 ft³/min) of air to the engine intake air filter. The intake air supply system shall be capable of controlling moisture content, dry bulb temperature, and inlet air pressure as specified in Tables 3 and 4 which is 11.4 ± 0.8 g/kg of dry air (79.8 ± 5.6 grains/lb of dry air), 27 ± 2°C (80.8 ± 3.6°F), and 0.05 ± 0.02 kPa (0.2 ± 0.1 in. H₂O). The specified engine intake air system components are

considered part of the laboratory intake air system and are shown in Fig. A2.18 and in the 1993 Ford Service manual, p. 03-12-2.⁹

6.8.1 *Intake Air Humidity*—Measure humidity with the laboratory’s primary humidity system. Correct each reading for non-standard barometric conditions, using the following equation:

$$\text{Humidity (corrected), grains/lb} = 4354 \times (P_{\text{sat}}/(P_{\text{bar}} - P_{\text{sat}})) \quad (1)$$

where:

P_{sat} = saturation pressure, in. Hg, and

P_{bar} = barometric pressure, in. Hg.

SI Units (Modernized Metric System):

$$\text{Humidity (corrected), g/Kg} = 621.98 \times (P_{\text{sat}}/(P_{\text{bar}} - P_{\text{sat}})) \quad (2)$$

where:

P_{sat} = saturation pressure, mm Hg, and

P_{bar} = barometric pressure, mm Hg.

6.8.2 *Intake Air Filtration*—The air supply system shall provide either water-washed or filtered air to the duct. Any filtration apparatus utilized shall have sufficient flow capacity to permit control of the air pressure at the engine.

6.8.3 *Intake Air Pressure Relief*—The intake air system shall have a pressure relief device located upstream of the engine intake air filter snorkel. The design of the relief device is not specified.

6.9 *Temperature Measurement*—The test requires the accurate measurement of oil, coolant, and fuel temperatures, and care must be taken to ensure temperature measurement accuracy. Follow the guidelines outlined by the research report.¹⁰

6.9.1 Check all temperature devices for accuracy at the temperature levels at which they are to be used. This is particularly true of the thermocouples used in the oil gallery, the coolant in, the inlet air, and the fuel to fuel rail. Iron-Constantine (Type J) thermocouples are recommended for temperature measurement, but either Type J or Type K (Chromel-Alumel) thermocouples may be used.

6.9.2 All thermocouples (excluding the oil heater thermocouple) shall be premium grade, sheathed types with premium wire. Use thermocouples of 3.2 mm (1/8 in.) diameter. Thermocouple lengths are not specified, but in all cases shall be long enough to allow thermocouple tip insertion to be in mid-stream of the medium being measured. The thermocouples shall not have greater than 5 cm (2 in.) of thermocouple sheath exposed to laboratory ambient.

6.9.3 Some sources of thermocouples that have been found suitable for this application are: Leeds and Northrup, Conax, Omega, Revere, and Thermo Sensor. In any case, match thermocouples, wires, and extension wires to perform in accordance with the special limits of error as defined by ANSI⁷ in publication MC96.1-1975.

6.9.4 System quality shall be adequate to permit calibration to $\pm 0.56^\circ\text{C}$ (1°F) for individual thermocouples.

6.9.5 *Thermocouple Location*—All thermocouple tips shall be located in the center of the stream of the medium being measured unless otherwise specified.

6.9.5.1 *Oil Inlet (Gallery)*—Insert the thermocouple into the modified oil filter adapter plate so that the thermocouple tip is flush with the face of the adapter and located in the center of the stream of flow as shown in Fig. A2.15 (that is, remove the O-ring from the adapter, place the adapter face on a flat surface, and insert the thermocouple into the adapter until the thermocouple tip is flush with the flat surface, and lock thermocouple into place).

6.9.5.2 *Oil Circulation*—Locate the oil circulation thermocouple in the tee in the rear of the oil pan where the oil from the external heat/cool circuit returns oil to the pan. The tip of the thermocouple shall be at the junction of the side opening in the tee with respect to the through passage in the tee.

6.9.5.3 *Engine Coolant In*—Locate the thermocouple tip in the center of the stream of flow and within 15 cm (5.9 in.) of the housing inlet.

6.9.5.4 *Engine Coolant Out*—Locate the thermocouple tip in the center of the stream of flow and in the coolant return neck within 8 cm (3.15 in.) of the housing outlet.

6.9.5.5 *Intake Air*—Locate the thermocouple in the Ford air cleaner assembly on the clean side of the filter as shown in Fig. A2.18.

6.9.5.6 *Fuel to Fuel Flow Meter*—Locate the thermocouple within 10 to 50 cm (3.9 to 19.7 in.) line length upstream of the fuel flow meter inlet.

6.9.5.7 *Fuel to Engine Fuel Rail*—Insert the thermocouple into the center of a tee or cross fitting and locate it a minimum of 15 cm (5.9 in.) downstream of the fuel pump and within 15 cm (5.9 in.) line length of the fuel rail inlet.

6.9.5.8 *Load Cell*—Locate the thermocouple within the load cell enclosure.

6.10 *AFR Determination*—Determine engine air-fuel ratio (AFR) by an AFR analyzer. Analysis equipment shall be capable of near continuous operation for 30 min periods.

6.10.1 The air fuel ratio analyzer shall meet the following specifications:

Measurement Range	AFR: 10.00 to 30.00 with H/C = 1.85, O/C = 0.00
Accuracy	± 0.1 AFR when 14.7 AFR with H/C = 1.85, O/C = 0.000

Temperature of exhaust gas used by sensor: -7 to 900°C . A Horiba model MEXA 110 analyzer has been found suitable for this application (see X1.25).

6.10.2 The specified location of the analyzer sensing element in the exhaust system is shown in Fig. A2.19.

6.11 *Exhaust and Exhaust Back Pressure Systems:*

6.11.1 *Exhaust Manifolds*—Use production cast iron exhaust manifolds, Ford Part No. F1AZ-9430 or F1AE-9430 (Casting No. RF F1AE-9430-BB) for right hand and Part No. F1AZ-9431 or F1AE-9431 (Casting No. RF F1AE-9431-BB) for left hand.

⁹ Available from HELM, Inc., 14310 Hamilton Avenue, Highland Park, MI 48203.

¹⁰ Supporting data have been filed at ASTM International Headquarters and may be obtained by requesting Research Report RR:D02-1218.

6.11.2 *Laboratory Exhaust System*—The exhaust system specified is shown in Fig. A2.19. Components can be radially oriented to ease installation, but install all components in the order shown. The design of the system downstream from the location shown in Fig. A2.19 is at the discretion of the laboratory.

6.11.3 *Exhaust Back Pressure*—The exhaust system shall have the capability for controlling exhaust back pressure to the pressures specified in Tables 2-4. The specified exhaust back pressure probe is shown in Fig. A2.20, and the specified exhaust back pressure probe location in the exhaust system is shown in Fig. A2.19.

6.12 *Pressure Measurement and Pressure Sensor Locations*—Pressure measurement systems for this test method are specified in general terms of overall accuracy and resolution with explicit pressure tap locations specified. Pressure devices (such as electronic transducers) shall follow the guidelines outlined by the research report.¹⁰

6.12.1 Connecting tubing between the pressure tap locations and the final pressure sensors should incorporate condensation traps as directed by good engineering judgement. This precaution is particularly important when low air pressures (as in this test method) are transmitted by way of lines which pass through low-lying trenches between the test stand and the instrument console. Pressure sensors should be mounted at the same elevation as the pressure taps.

6.12.2 *Engine Oil*—Locate the pressure tap for the engine oil pressure at the oil filter adapter. Accuracy of 1 % with 6.9 kPa (1 psi) resolution is required.

6.12.3 *Fuel to Fuel Flow Meter*—Locate the pressure tap within 5 m from the fuel inlet of the fuel flow meter. Accuracy of 3.5 kPa (0.5 psi) is required.

6.12.4 *Fuel to Engine Fuel Rail*—Locate the pressure tap a minimum of 15 cm (5.9 in.) from the outlet of the car type fuel pump and within 15 cm (5.9 in.) line length of the inlet to the fuel rail. Accuracy of 3.5 kPa (0.5 psi) is required.

6.12.5 *Exhaust Back Pressure*—Locate the exhaust back pressure probe as shown in Fig. A2.19. The sensor shall be accurate to within 2 % of full scale with resolution of 25 Pa (0.1 in. H₂O).

6.12.6 *Intake Air*—Measure the intake air pressure at the location shown in Fig. A2.18. Sensor/readout accuracy required is 2 % of full scale with resolution of 5.0 Pa (0.02 in. H₂O).

6.12.7 *Intake Manifold Vacuum/Absolute Pressure*—Measure the intake manifold vacuum/absolute pressure at the throttle body adapter. A sensor having accuracy within 1 % of full scale and with 0.68 kPa (0.1 in. Hg) resolution is required.

6.12.8 *Coolant Flow Differential Pressure*—See 6.5.9.

6.12.9 *Crankcase Pressure*—Locate the crankcase pressure tap as detailed in Annex A12 and Fig. A2.22.

6.13 *Engine Hardware and Related Apparatus*—This section describes engine-related apparatus requiring special purchase, assembly, fabrication, or modification. Part numbers not otherwise identified are Ford service part numbers.

6.13.1 *Test Engine Configuration*—The test engine is a 1993 4.6-L Ford V-8 engine equipped with fuel injection. Purchase the engine as a test ready unit (for procurement, see

X1.3). The engine may not be disassembled and shall be used in an as received condition. Only external engine dress items are to be installed by the laboratory.

6.13.2 *ECM/EEC (Engine Control) Module*—Use a special modified ECM/EEC IV, Part No. OHT6A-002-1 engine control module, Ford part name SMO-100 (see X1.26). This module controls ignition and fuel supply functions.

6.13.3 *Thermostat/Orifice Plate*—Use an orifice plate as shown in Fig. A2.21 in place of the thermostat. The orifice plate can be fabricated by the laboratory or procured as Part No. OHT6A-004-1 (see X1.27).

6.13.4 *Intake Manifold*—Modify the intake manifold, Part No. F1AZ-9424-C, F1AE-9424, or F1AE-9425. Plug the intake manifold coolant bypass passage (port under the orifice plate).

6.13.5 *Flywheel*—A manual flywheel, Part No. F6ZZ-6375-AB, is required. Modify the flywheel according to laboratory practice to allow for connection to the test stand driveshaft. Purchase this part from the CPD (see X1.38).

6.13.6 *Wiring Harnesses*—Two wiring harnesses are used. One is a fuel injector sub-harness and the other is an engine ECM/EEC wiring harness. The fuel injector sub-harness is to be one of the following part numbers: F3VB-12522, F3VB-12A522, F3AB-12A522, F2AZ-9D930-A, F3AZ-12A522, or F3BL-12A522. These harnesses are available from the CPD (see X1.38) and are similar to that shown in the 1993 Ford service manual, Figure K16182-A, p. 18-01-21. Disconnect items 11, 14, 21, and 23 shown in Figure K16182-A from the harness. The other wiring harness is a special dyno engine wiring harness, Part No. OHT6A-001-1 (see X1.28) and is used to connect the car-type harness to the ECM/EEC.

NOTE 5—A full size version of the schematic may be obtained from the TMC; see X1.2.

6.13.7 *EGR Block-Off Plate*—Remove the EGR valve and replace with a block-off plate which is to be fabricated by the laboratory. Cut off the EGR tube near the exhaust manifold, crimp and weld shut or plug.

6.13.8 *Oil Pan*—Use oil pan, Part No. F1AZ-6675-A or F2AZ-6675-A. Modify the oil pan as detailed in 6.6.5.14 and Figs. A2.10-A2.13.

6.13.9 *Oil Pump Screen and Pickup Tube*—Use oil pump screen and pickup tube, Part No. F2AZ-6622. Remove the oil pump screen and modify the pickup tube as detailed in 6.6.5.15.

6.13.10 *Idle Speed Control Solenoid (ISC) Block-Off Plate*—Remove the idle speed control solenoid (idle air bypass valve) and replace with a block-off plate which is to be fabricated by the laboratory.

6.13.11 *Engine Water Pump*—Modify or replace as detailed in 6.5.10.

6.13.12 *Thermostat Housing*—Use thermostat housing, Part No. F1VY-8592-A or F1AE-8594. Modify for engine coolant out thermocouple installation (see 6.9.5.4) or procure as Part No. OHT6A-010-1 (see X1.29).

6.13.13 *Oil Filter Adapter*—Use oil filter adapter, Part No. F1AZ-6881, F1AE-6881, or F1AE-6884. Modify for engine coolant in thermocouple installation (see 6.9.5.3) or procure as Part No. OHT6A-009-1 (see X1.30).

6.13.14 *Fuel Rail*—Use fuel rail, Part No. F2AZ-9F792-A or F2AE-9F792. Purchase this part from the CPD (see X1.38). Modify the fuel rail inlet and outlet connections for connection to the laboratory fuel supply system.

6.14 *Miscellaneous Apparatus Related to Engine Operation*:

6.14.1 *Timing Light*—Use an inductive pickup type timing light during the test. (**Warning**—Some types of timing lights will read out double the actual ignition timing when used on this engine.)

7. Reagents and Materials

7.1 Engine Oil:

7.1.1 ASTM Baseline Calibration Oil (BC) (see X1.2) is used for new engine break-in and as a primary calibration oil for evaluation of test oils. It is an SAE 5W-30 grade. Approximately 38-L (10 gal) of BC oil are required for each test.

7.1.2 ASTM BC Flush Oil (BCFHD) (see X1.2) is a special flushing oil (BC oil with increased solubility) which is used when changing oil after a test oil has been in the engine. Approximately 6 L (6.34 qt) of Flush Oil are required for each test.

7.2 *Test Fuel*—Use only Haltermann (see X1.37) HF 003 fuel.¹¹ (**Warning**—Danger! Extremely flammable. Vapors harmful if inhaled. Vapors may cause flash fire (see A6.2.2.1).)

7.2.1 Make certain that all tanks used for storage are clean before they are filled with test fuel.

7.2.2 *Laboratory Fuel Sampling and Analysis*—The need for this action and analytical methods to be used are under study by ASTM D02.B0.01. Upon determination, an Information Letter will be published by the Test Monitoring Center.

7.2.3 *Fuel Batch Usage/Documentation*—A complete test sequence shall be run on a single batch of test fuel. If a new batch of test fuel is introduced to the laboratory fuel supply system, it shall be done between finite tests. Document the fuel batch designation in the test report. In cases where the run tank contains more than one fuel batch, document the most recent fuel batch in the report.

7.3 *Engine Coolant*—The engine coolant shall be 50/50 volume % commercial additized ethylene glycol coolant/water. Water shall be deionized, demineralized, or distilled.

7.4 Cleaning Materials:

7.4.1 *Organic Solvent Penmul L460*—See X1.32. (**Warning**—Harmful vapor. Store at moderate temperature (see A6.2.2.2).)

7.4.2 *Aliphatic Naphtha*—See X1.33. (**Warning**—Combustible. Harmful vapor (see A6.2.2.3).)

7.4.3 *Engine Cooling System Cleanser*—Consists of the following (see X1.34): (**Warning**—Toxic substance. Avoid contact with eyes, skin, and clothing (see A6.2.2.4).)

7.4.3.1 *Oxalic Acid Dihydrate Tech.* (**Warning**—Toxic substance. Avoid contact with eyes, skin, and clothing (see A6.2.2.5).)

7.4.3.2 *Alkylated Naphthalene, Sodium Salt*—Petro Dispersant 425 (soap).

7.4.3.3 *Soda Ash Light*—Neutralization.

8. Preparation of Apparatus

8.1 This section assumes that the engine test stand facilities and hardware as described in Section 6 are in place. Emphasis is on the recurring preparations needed in the routine conduct of the test.

8.2 Test Stand Preparation:

8.2.1 *Instrumentation Preparation*—Perform the calibration of the temperature measuring system, the dynamometer load measuring system, the fuel flow measuring system and the pressure measuring system (see 10.2 for additional details concerning instrumentation calibration) in a manner consistent with good laboratory practices and record it for future reference.

8.2.2 *External Oil System Cleaning*—Clean the entire external oil system using cleaning solvent (see 7.4.1) each time a newly built engine is installed.

8.2.3 *Exhaust Back Pressure Probe Renewal*—The exhaust back pressure probe can be used until it becomes cracked, brittle, or deformed. Clean the outer surface of the probe and clear all port holes. Check the probe for possible internal obstruction and reinstall the probe in the exhaust pipe. Stainless steel probes are generally serviceable for several tests; mild steel probes tend to become brittle after fewer tests.

8.2.4 *AFR Sensor Renewal*—Inspect AFR sensor (see 10.2 for AFR system calibration requirements).

8.2.5 *Hose Replacement*—Inspect all hoses and replace any that are deteriorated. Check for internal wall separations which would cause flow restriction.

9. Engine Preparation

9.1 Purchase the engine as a test ready unit (for procurement, see X1.3). The engine will not be disassembled and shall be used in an as received condition. The only exceptions are external engine dress items are to be installed by the laboratory and the valve stem seals can be replaced when necessary. Utilize Ford service parts for a 1993 model year engine or Sequence VIB parts.

9.2 Cleaning of Engine Parts:

9.2.1 *Cleaning*—Soak any parts to be cleaned in degreasing solvent until clean (see X1.33).

9.2.2 *Rinsing*—Wash the parts thoroughly with hot water.

9.3 Engine Assembly Procedure:

9.3.1 *General Assembly Instructions*—Assemble the external engine dress components according to the detailed description in the 1993 Ford Service Manual. However, in cases of disparity, the explicit instructions contained in this test method take precedence over the service manual. Additional information is available in the Ford 543 Engine Assembly Manual, 1999 Edition.¹²

9.3.2 *Bolt Torque Specifications*—When installing the engine components, use a calibrated torque wrench to obtain the

¹¹ Available from Haltermann Products, 1201 South Sheldon Road, P.O. Box 429, Channelview, TX 77530-0426. Phone: (713) 457-2768, (713) 457-2768, (800) 969-2542.

¹² Available from the ASTM Test Monitoring Center Web Page at <http://astmtmc.cmu.edu>

values specified. Specifications are shown in the 1993 Ford Service Manual. These specifications are for clean and lightly lubricated threads only. Dirty or dry threads produce friction which prevents accurate measurements of the actual torque. It is important that these specifications be observed. Over tightening can damage threads which may prevent attainment of the proper torque and may require replacement of the damaged part.

9.3.3 Sealing Compounds—Sealing compounds are not specified. Use engineering judgement governing the use of sealing compounds. Do not use sealers in tape form (loose shreds of tape can circulate in the engine oil and plug critical orifices).

NOTE 6—Silicone-based sealers may raise the indicated Si content of used oil.

9.3.4 New Parts Required for Each New Engine (see X1.3) are listed in Annex A4.

9.3.5 Harmonic Balancer—The balancer, Part No. F1AZ-6316-A, is included on the engine by the engine supplier.

9.3.6 Oil Pan—Install the oil pan, Part No. F1AZ-6675-A or F2AZ-6675-A, modified as detailed in 6.6.5.14 and as shown in Figs. A2.10-A2.13. Use gasket, Part No. F1AZ-6710-A. Torque the bolts in the sequence shown in 1993 Ford Service Manual, Figure A14940-B, p. 03-01-39.

9.3.7 Intake Manifold—Install intake manifold, Part No. F1AZ-9424-C, F1AE-9424, or F1AE-9425. Modify the intake manifold as detailed in 6.13.4. Purchase this part from the CPD (see X1.38). Use gaskets, Part No. F1AZ-9461-A. Torque the bolts in the sequence shown in 1993 Ford Service Manual, Figure A14812-A, p. 03-01-32.

9.3.8 Camshaft Covers—Camshaft covers are, right hand, Part No. F1AZ-6582-A; left hand, Part No. F1AZ-6582-B. Use gaskets, right hand, Part No. F1AZ-6584-A; left hand, Part No. F1AZ-6584-B. These are included on the engine by the engine supplier.

9.3.9 Thermostat—Remove the thermostat and replace with a thermostat orifice plate as shown in Fig. A2.21 (see X1.27). See 6.13.3.

9.3.10 Thermostat Housing—Install a modified thermostat housing (see 6.13.12), Part No. F1VY-8592-A, F1AE-8594, or OHT 6A-01010-1 (see X1.12). Use gasket, Part No. F1VY-8255-A.

9.3.11 Coolant Inlet—Modify the coolant inlet connection which is cast as a part of the oil filter adapter (see 9.3.12 and 6.13.13).

9.3.12 Oil Filter Adapter—The oil filter adapter is Part No. F1AZ-6881, F1AE-6881, or F1AE-6884 and is included on the engine by the engine supplier. Modify the adapter (see 6.13.13). Use gasket, Part No. F1AZ-6840-A.

9.3.13 Dipstick Tube—Dipstick tube, Part No. F1AZ-6754-A is included on the engine by the engine supplier.

9.3.14 Water Pump—Install a modified water pump or a water pump plate (see 6.5.10 and Fig. A2.6).

9.3.15 Sensors, Switches, Valves, and Positioners:

9.3.15.1 Oil Pressure Switch and Oil Pressure Sensor—Install oil pressure switch, Part No. E9SZ-9278-A. The oil pressure sensor may be removed and the location plugged.

9.3.15.2 Camshaft Positioner Sensor (CMP)—Camshaft position sensor, Part No. F1AZ-6B288-A, is included on the engine by the engine supplier.

9.3.15.3 Crankshaft Position Sensor (CKP)—Crankshaft position sensor, Part No. F1AZ-6C315-A, is included on the engine by the engine supplier.

9.3.15.4 Water Temperature Indicator Sender Unit—Install water temperature indicator sender unit, Part No. F1SZ-10884-A or F1SF-10884.

9.3.15.5 Idle Speed Control Solenoid (ISC)—Idle air control valve (idle air bypass valve) is not used; replace with by a block-off plate (see 6.13.10).

9.3.15.6 EGR Valve—The EGR valve is not used. Replace with a block-off plate (see 6.13.7).

9.3.15.7 EGR Valve Positioner Sensor (EVP)—EGR Valve Position sensor is not used.

9.3.15.8 EGR Vacuum Regulator Sensor (EVR)—EGR vacuum regulator sensor is not used. Plug the vacuum lines that would normally be connected to this sensor.

9.3.15.9 Throttle Position Sensor (TP)—Install throttle position sensor, Part No. F2AZ-9B989-A or FZAF-9B989. Purchase this part from the CPD (see X1.38).

9.3.15.10 Engine Coolant Temperature Sensor (ECT)—Install engine coolant temperature sensor, Part No. F2AZ-12A648-A or F2AF-12A648. Purchase this part from the CPD (see X1.38).

9.3.15.11 Heated Exhaust Gas Oxygen Sensors (HEGO)—Use heated exhaust gas oxygen sensors, Part No. F0TZ-9F472, F0SZ-9F472-A, F1SZ-9F472-A, or XL3Z-9F472. Make sure that the HEGO's are correctly connected. The left side (cylinders 5-8) sensor harness has a red with black stripe wire coming from the bottom right pin of the connector when looking at the plug from the front. The right side sensor (cylinders 1-4) has a gray with light blue striped wire in this position. Purchase this part from the CPD (see X1.38).

9.3.15.12 PCV—Remove the PCV valve and vent all PCV points of connection to the crankcase pressure control system as detailed in Annex A12 and Fig. A2.22 (see 6.12.9). Plug all associated vacuum lines.

9.3.15.13 Air Charge Temperature (ACT) Sensor—Use ACT sensor, Part No. F2DZ-12A697. Purchase this part from the CPD (see X1.38).

9.3.15.14 Mass Air Flow Sensor—Use mass air flow sensor, Part No. F0TZ-12B579 or F2VF-12B579 (70 mm diameter). Purchase this part from the CPD (see X1.38).

9.3.16 Ignition System:

9.3.16.1 Ignition Coils—Install right hand and left hand ignition coils, Part No. F1VY-12029, F1VU-12029, F3VU-12029, or F5LU-12029. Use Ignition coil bracket, right hand Part No. F3AZ-12257 and left hand Part No. F3AZ-12257.

9.3.16.2 Ignition Wires—Install ignition wires, Part No. F3PZ-12259-C. Position spark plug wires 45° from centerline of crankshaft to the coil (outboard and forward), to ensure boot seal is fully seated against cylinder head (1993 Ford Service Manual, Figure B4477-D, p. 03-07-6).

9.3.16.3 Ignition Control Module (ICM)—Install ignition control module, Part No. F1AZ-12K072-A or F1AF-12K072. Purchase this part from the CPD (see X1.38).

9.3.16.4 *Spark Plugs*—Use spark plugs, Part No. AWSF 32C or 32P. Spark plug gap shall be 1.31 to 1.41 mm (0.052 to 0.056 in).

9.3.17 *Fuel Injection System:*

9.3.17.1 *Fuel Injectors*—Use fuel injectors, Part No. F0TZ-9F593. Refer to Annex A10 for injector flow specifications. Verification of each injector is required prior to use. Purchase this part from the CPD (see X1.38).

9.3.17.2 *Fuel Rail*—Install modified fuel rail, Part No. F2AZ-9F792-A or F2AE-9F792 9 (see 6.13.14). Purchase this part from the CPD (see X1.38).

9.3.17.3 *Fuel Pressure Regulator*—Use fuel pressure regulator, Part No. E6AZ-9C968 or E7DE-9C968. Purchase this part from the CPD (see X1.38).

9.3.18 *Intake Air System*—The engine intake air system components may be oriented according to laboratory requirement. However, use all of the specified components.

9.3.18.1 *Air Cleaner Outlet Tube Assembly (Air Box)*—Use air cleaner outlet tube, Part No. F2AZ-9B659. Install with air cleaner outlet tube clamp (which comes with the outlet tube) and bolt, Part No. F2AZ-9A624-A. Purchase these parts from the CPD (see X1.38).

9.3.18.2 *Crankcase Ventilation Tube*—Remove crankcase ventilation tube, Part No. F1AZ-6C324-A, and plug the port in the air cleaner assembly.

9.3.18.3 *Engine Air Cleaner Assembly*—Use engine air cleaner assembly, Part No. F2AZ-9600. Modify the assembly (see Fig. A2.18). Purchase this part from the CPD (see X1.38).

9.3.18.4 *Air Cleaner Element*—Use air cleaner element, Part No. E5TZ-9601.

9.3.18.5 *Resonator Box*—Use resonator box, Part No. F2AE-9R504.

9.3.18.6 *Throttle Body*—Use throttle body, Part No. F2AZ-9E926 or F2AE-9E926. Purchase this part from the CPD (see X1.38).

9.3.18.7 *Throttle Body Adapter*—Use throttle body adapter, Part No. F2AE-9A589 or F1-VY-9A589. Purchase this part from the CPD (see X1.38).

9.3.19 *Engine Management System (Spark and Fuel Control):*

9.3.19.1 *Engine Wiring Harness*—Use a special engine wiring harness, Part No. OHT6A-001-01. Purchase this part from the SPD (see X1.28).

9.3.19.2 *Engine Control Module*—Use EEC IV engine control module, Part No. OHT6A-002-1, or OHT6A-002-3 ECM/EEC (see X1.26). This module controls ignition and fuel supply functions.

(1) Supply the EEC power from a battery or a regulated power supply (12 V to red wire). Ground the EEC ground wire to the engine. When using a battery, run a 2-gage wire back to the battery negative to prevent interruption/interference of the EEC operation.

(2) Measure and verify the ignition timing after every new ECM installation. The ignition timing shall be 20° BTDC $\pm 2^\circ$ (see Table 3).

9.3.19.3 *Keep Alive Memory (KAM)*—Disconnect the keep alive memory from the 12 V supply (yellow wire) while running oil tests.

9.3.20 *Accessory Drive Units*—Do not use external drive units, including alternators, fuel pumps, power steering units, air pumps, air conditioning compressors, and so forth.

9.3.21 *Exhaust Manifolds*—Use exhaust manifolds, right hand Part No. F1AZ-9430-B and left hand Part No. F1AZ-9431-B. Torque bolts in the sequence shown in the 1993 Ford Service Manual, Figure A13673-A, p. 03-01-34.

9.3.22 *Engine Flywheel and Guards*—The flywheel is a Ford production unit, Part No. F6ZZ-6375-AB, manual flywheel. Purchase this part from the CPD (see X1.38). Install an engine flywheel guard and safety housing to suit test stand requirements. Modify the flywheel according to laboratory practice to allow for connection to the test stand driveshaft.

9.3.23 *Lifting of Assembled Engines*—Assembled engines shall not be lifted by the intake manifold since this is known to cause engine coolant leaks. Refer to 1993 Ford Service Manual for proper lifting instructions and lift locations.

9.3.24 *Engine Mounts*—Special dynamometer laboratory engine mounts have been found suitable for this application and may be used. These may be ordered using Part No. DTSC-080-128-001 for the right side and Part No. DTSC-80-126-1 for the left side (see X1.35). The right hand and left hand mount isolators (biscuits) are Part No. DTSC-40-132-1 (see X1.36). Rear mount configuration should be according to laboratory practice.

9.3.25 *Valve Stem Seals*—Valve stem seals may be replaced at the laboratory discretion. Use the 1993 Ford Service Manual procedure and recommended tools when the seals are replaced. The required replacement seal is Part No. F6AZ-6571-AA. Replace the seals immediately prior to a calibration test.

9.3.26 *Valve Spring*—Use valve spring, Part No. F1AE-6513-AC, that meet material requirements of No. WDS-M1A314-A1. Valve springs may be replaced on Sequence VIB engines either prior to new engine break-in or prior to the next calibration test. Operate an engine that has been previously calibrated, and has had new valve springs installed, for 80 h of Phase II aging conditions before starting a calibration test. Changing just one valve spring in an engine is not permitted; all old valve springs must be replaced with new ones.

9.3.27 *Timing Chain Tensioner Assembly*—The timing chain tensioner assembly or any of the individual parts of the timing chain assembly may be replaced as needed. The individual parts include the timing chain tensioner arms (left and right), timing chain, timing chain guide, crankshaft sprockets, and camshaft sprockets. A calibration test is required immediately after replacing one or all of the above parts. Identify in the comments section of the test report which part(s) were replaced. If an engine was built with a link type camshaft chain, it may be replaced with a roller type chain and sprockets. The above parts are available through any local Ford dealership. Specify replacement parts for a Ford 4.6L, 1993 model year engine.

10. Calibration

10.1 *Stand/Engine Calibration*—To ensure proper response to various oil parameters, conduct a reference oil test when a new or previously used test engine is installed in a test stand. This event will be monitored by the ASTM TMC. See 11.1.2 prior to attempting calibration of a new stand. The TMC will

assign reference oils for calibration tests. The reference oils used to calibrate Sequence VIB engine test stand/engine combinations have been formulated or selected to represent specific chemical types or performance levels or both. These oils are normally supplied under code numbers (blind reference oils) to ensure that the testing laboratory is not influenced by preconceived opinions in assessing test results. Number each Sequence VIB test to identify the stand number, the number of runs on that stand, the engine number and the number of runs on the engine. For example, 56-21-3-8 defines a test on stand 56, which is the 21st test on stand 56, engine number 3, and the 8th test on engine number 3. For reruns of operationally invalid or unacceptable reference oil the stand run number shall be incremented by one and the engine run number shall be followed by the letter A for the first re-run, B for the second re-run, and so forth. For example, the next test number for an operationally invalid or unacceptable test would be 56-22-3-8A.

10.1.1 *Procedure*—Test stand/engine calibration is accomplished by conducting tests on ASTM TMC reference oils (see X1.2). Reference oil tests on each test stand/engine combination within a laboratory which is to be considered calibrated shall be conducted according to ASTM TMC Lubricant Test Monitoring System (LTMS) guidelines. Do not terminate a reference test due to an FEI result. For a given test stand/engine combination, following the first calibration period of a new stand/engine combination, conduct a minimum of one operationally valid, statistically acceptable reference oil test after 4 non-reference oil tests starts or after 90 days have elapsed, whichever occurs first. Thereafter conduct a minimum of one operationally valid, statistically acceptable reference oil test after 7 non-reference oil tests starts or after 90 days have elapsed, whichever occurs first. The 90 elapsed days are judged from the end-of-test (EOT) day of the last operationally valid, statistically acceptable reference oil test to the start-of-test (SOT) day of a calibrated non-reference oil test. If more than 90 days elapse between Sequence VIB tests, EOT to SOT, on a stand/engine combination, a minimum of one operationally valid, statistically acceptable (according to LTMS) test is required. If acceptable results are obtained on the reference oil the test stand/engine is calibrated. Re-reference the engines once removed from the test stand and re-installed, even if the test number and time criteria are met by the engine. Laboratories shall inform the TMC with a written explanation when a test engine is removed from a test stand and installed into another test stand. Only appropriate Sequence VIB test engines (see X1.3) may be referenced.

10.1.1.1 The effective date of a reference test is the LTMS date and time of the reference test. Test start time is defined as the introduction of the reference oil into the engine. The LTMS date and time are defined as the date and time the test was completed (completion of the BC run following the reference oil) unless a different date and time are assigned by the TMC. The TMC may schedule more frequent reference oil tests (or approve less frequent reference oil tests) at its discretion. Under special circumstances (that is, extended downtime due to industry-wide parts or fuel outages) the TMC may extend

reference periods. Note non-reference oil tests conducted during the extended time allowance in the test note section of the report.

10.1.1.2 Failure of a reference oil test to meet Shewhart or Exponentially Weighted Moving Average (EWMA) control chart limits can be indicative of a false alarm, engine, test stand, or industry related problem. When this occurs, the laboratory, in conjunction with the TMC, shall attempt to determine the problem source. The ASTM Sequence VIA/VIB Surveillance Panel adjudicates industry problems. The TMC will decide, with input as needed from industry expertise (testing laboratories, test procedure developer, ASTM Technical Guidance Committee, Surveillance Panel, and so forth) if the reason for any unacceptable blind reference oil test is isolated to one particular engine or stand or related to other stands. If it is decided that the problem is isolated to an individual engine or stand, calibrated testing on other stands may continue throughout the laboratory. The laboratory may elect to attempt additional reference oil tests in the same engine. In the event the engine does not attain calibration, the laboratory shall remove the engine and go through the normal process of calibrating a new engine. Operationally valid, statistically unacceptable data on removed engines will be included in all appropriate databases (industry reference oil severity and precision) unless the engine failing to calibrate is a new engine (has never been calibrated and conducted non-reference oil tests).

10.1.1.3 If non-standard tests are conducted on a calibrated engine or test stand, recalibrate the stand and engine prior to running standard tests.

10.1.2 *Reporting of Reference Results*—Transmit the reference oil test results to the TMC (see Annex A1) using Forms 1, 4, 5, 6, and 18 shown in Annex A7 immediately after completion of test. The TMC will review the transmitted reference oil test results and use the Lubricant Test Monitoring System (LTMS) to determine test acceptability. The complete final test report package as defined in Annex A7 shall be received within 30 days of test completion by the following party:

Manager of Operations
 ASTM TMC
 6555 Penn Avenue
 Pittsburgh, PA 15206-4489

10.1.3 *Analysis of Reference/Calibration Oils:*

10.1.3.1 *Reference Oils Identification*—Do not subject reference oils to either physical or chemical analyses for identification purposes. Identifying the oils by analyses could undermine the confidentiality required to operate an effective blind reference system. Therefore, reference oils are supplied with the explicit understanding that they will not be subjected to analyses other than those specified within this procedure unless specifically authorized by the TMC. In such instances, supply written confirmation of the circumstances involved, the data to be obtained, and the name of the person requesting the analysis to the TMC.

10.1.3.2 *BC Baseline Calibration Oil and BCFHD Flush Oil*—The Baseline Calibration (BC) Oil and BCFHD Flush Oil may be analyzed only to the extent required to evaluate the

effectiveness of a test stand's flushing system. This analysis will be limited to molybdenum content. Do not subject the BC oil or BCFHD oil to further physical or chemical analyses other than those specified within this procedure unless specifically authorized by the TMC. In such instances, supply written confirmation of the circumstances involved, the data to be obtained, and the name of the person requesting the analysis to the TMC.

10.2 Instrument Calibration—Record all instrument calibrations for further reference. Perform a complete test stand instrument calibration prior to conducting the initial reference test in a new engine. A previously calibrated (existing) stand/engine will require that the following be calibrated prior to the next reference test: (1) engine load measurement system; (2) fuel flow meter; (3) engine speed; (4) AFR analysis equipment; and (5) exhaust back-pressure equipment.

10.2.1 Engine Load Measurement System—Calibration by use of deadweights is required at the start of a test and before each reference oil test. Prior to calibration, start the engine and run for a minimum of 30 min at 1500 r/min, 37 N·m. Shut the engine down, leave dynamometer cooling water on, and start performing the load cell calibration within 3 min after shut-down.

10.2.1.1 Perform the calibration at the 3 designated torques (approximately 26, 37, and 98 N·m). The stand load measurement system shall perform within ± 0.3 N·m of the calibration standard.

10.2.2 Fuel Flow Measurement System—Use accurate mass scale measurements for calibrating. Perform this calibration at three fuel flow rates (approximately 1.4, 3.2, and 5.4 kg/h). Evaluate each flow rate a minimum of three times to verify repeatability.

10.2.2.1 The test stand flowmeter shall perform to within 0.25 % at 5.4 kg/h, 0.32 % at 3.2 kg/h, and 0.54 % at 1.4 kg/h of the calibration standard. For each flow rate, a minimum of three consecutive flow readings shall be within the specified tolerance. The calibration standard shall be at least 4 times more accurate than the test stand flowmeter at each specified flow rate.

10.2.3 Coolant Flow Measurement System—Calibrate the flow measuring device a minimum of once every three months.

10.2.4 Thermocouple and Temperature Measurement System—The calibration of the test stand temperature measurement system (thermocouple through readout) is checked at the test stand using the existing readout system prior to running a new engine reference or a minimum of once every three months whichever occurs first. For the critical temperatures (see Table 3) the individual temperature sensors shall indicate within $\pm 0.56^\circ\text{C}$ ($\pm 1^\circ\text{F}$) of the laboratory calibration standards. The calibration equipment utilized shall be appropriate for the $\pm 0.56^\circ\text{C}$ ($\pm 1^\circ\text{F}$) accuracy level here specified. See 6.9 for additional thermocouple calibration requirements.

10.2.5 Humidity Measurement System—Calibrate the primary laboratory measurement system at each stand on a semiannual basis using a hygrometer with a minimum dew point accuracy of $\pm 0.55^\circ\text{C}$ at 16°C ($\pm 1^\circ\text{F}$ at 60°F). Locate the sample tap on the air supply line to the engine in the intake air cleaner.

10.2.5.1 The calibration consists of a series of paired humidity measurements comparing the laboratory system with the calibration hygrometer. The comparison period lasts from 20 min to 2 h with measurements taken at 1 to 6 min intervals, for a total of twenty paired measurements. The measurement interval shall be appropriate for the time constant of the humidity measuring instruments.

10.2.5.2 Verify that the flow rate is within the equipment manufacturer's specification, and that the sample lines are non-hygroscopic. Correct dew point hygrometer measurements to standard conditions (101.12 kPa [29.92 in. Hg]) using the appropriate equation (see 6.8.1). Compute the difference between each pair of readings and calculate the mean and standard deviation of the twenty paired readings, using Eq A8.1 and Eq A8.2 in Annex A8. The absolute value of the mean difference shall not exceed 1.43 g/kg (10 grains/lb), and the standard deviation shall not be greater than 0.714 g/kg (5 grains/lb). If these conditions are not met, investigate the cause, make repairs, and recalibrate. Maintain calibration records for two years.

10.2.6 Other Instrumentation—As a minimum, calibrate instrumentation for measuring parameters other than those detailed in 10.2-10.2.5 after every 10 non-reference oil tests or every 90 days, whichever occurs first.

11. Test Procedure

11.1 Preparation for Initial Start-Up of New Engine—Measure and verify the ignition timing according to the specification shown in Table 3.

11.1.1 External Oil System—The external oil system shall be cleaned each time a new engine is installed (see 8.2.2). If this is a new test stand, demonstrate the flush effectiveness.

11.1.2 Flush Effectiveness Demonstration—A laboratory shall demonstrate the flush effectiveness of their flying flush oil system for any new stand and for any stand which has had modifications made to the oil system. By using an oil containing molybdenum a laboratory shall demonstrate a 99 % flush effectiveness, by Inductive Coupled Plasma (ICP), after the final flush of a detergent flush (see 11.5.9.1, 10) when detergent flushing from the demonstration oil to BC oil. ASTM Oil FEEO-103 (FM) has proven satisfactory for use in this demonstration. The procedure is as follows (FM = ASTM FEEO-103 (FM) or other suitable oil containing molybdenum):

11.1.2.1 With the engine already charged with BC oil, warm engine to Stage Flush (see Table 4).

11.1.2.2 Take a 118-mL (4-oz) sample of the FM oil from the oil reservoir (Sample New Oil).

11.1.2.3 Flush in FM oil, run 30 min.

11.1.2.4 Flush in FM oil, run 30 min.

11.1.2.5 Flush in FM oil (this completes the FM oil change).

11.1.2.6 Run 30 min, take a 118-mL (4-oz) purge sample and pour back into the engine. Take a 118-mL (4-oz) retain sample (Sample 1).

11.1.2.7 Flush to BCFHD Flush oil, run 30 min.

11.1.2.8 Flush to BCFHD Flush oil, run 2 h, take a 118-mL (4-oz) purge sample and pour back into the engine. Take a 118-mL (4-oz) retain sample (Sample 2).

11.1.2.9 Flush in BC oil, run 30 min, take a 118-mL (4-oz) purge sample, pour back into engine. Take a 118-mL (4-oz) retain sample (Sample 3).

11.1.2.10 Flush in BC oil, run 30 min, take a 118-mL (4-oz) purge sample and pour back into engine. Take a 118-mL (4-oz) retain sample (Sample 4).

11.1.2.11 Flush in BC oil, take a 118-mL (4-oz) purge sample and pour back into engine. Take a 118-mL (4-oz) retain sample (Sample 5).

11.1.2.12 *Analyze Samples*—Analyze new oil, 1, 2, 3, 4, and 5 by ICP for the molybdenum and report the results to TMC (Comparison is Sample 11.1.2.11 versus 11.1.2.6).

11.1.3 *Preparation for Oil Charge*—Check the apparatus carefully to be sure that all oil lines and fittings are properly tightened and aligned. This includes the apparatus for the flying flush oil change system.

11.1.4 *Oil Charge for Coolant Flush*—Service both oil filters (see 6.6.5.9) to ensure they are clean and that the seals are in good condition. Charge the engine with 6.0 L (6.34 qt) of fresh BC oil.

11.1.5 *Engine Coolant Charge for Coolant Flush*—The hoses or tubing leading from the venturi coolant flowmeter to the differential pressure sensor may be isolated (by closing the valves or disconnecting the hoses) to prevent contamination of the water in these hoses.

11.1.5.1 Prepare cooling system cleanser solution by adding oxalic acid at the ratio of 23 g/L (3 oz/gal) and adding Petro Dispersant 425 at the ratio of 1 g/L (0.15 oz/gal) of water for the coolant flush charge (see 7.4.3 and X1.34). Charge the coolant system with this solution.

11.2 *Initial Engine Start-Up*—Connect the fuel line to the engine fuel rail or open the fuel shut-off valves, or both. Ready the control console (engine ignition on, external oil circulation pump on, safety circuits ready). Crank the engine. When the engine is running at idle (approximately 800 r/min, zero load), check for fuel, oil, coolant, water, and exhaust leaks. Connect the intake air supply duct. During idle, check the ignition timing to verify it is 20° BTDC.

11.3 *Coolant Flush:*

11.3.1 Operate the engine at idle conditions (800 r/min, no load) for 40 min while maintaining a coolant temperature of $65 \pm 5^\circ\text{C}$ ($150 \pm 10^\circ\text{F}$). Then open the engine block petcock and heat exchanger drain valve. Add fresh tap water to the system until the drains run clear. Continue adding fresh tap water to the system for 5 min after the drains begin running clear. Close the block and heat exchanger drains and add the cooling system neutralizer (sodium carbonate) (see 7.4.3) which has previously been mixed at the ratio of 3.8 g/L (0.50 oz/gal) of hot water.

11.3.2 After the engine has run for 45 min with the neutralizer while maintaining a coolant temperature of $65 \pm 5^\circ\text{C}$ ($150 \pm 10^\circ\text{F}$) open the drain valves and add fresh water until the drains run clear. (The pH of the incoming and outgoing water shall be the same at this point). Stop adding fresh water, close drain valves, and run engine for 20 min under coolant flushing operating conditions.

11.3.3 Shut down engine using the procedure given in 11.5.8. Disconnect the intake air supply duct as soon as the engine is shut down.

11.3.4 Drain coolant.

11.3.5 Fill coolant system with pre-mixed coolant consisting of 50/50 volume % mixture of additized ethylene glycol coolant and deionized, demineralized, or distilled water (see 7.3).

11.3.6 Coolant charge may be reused for additional tests, however, install new coolant each time a new engine is installed.

11.3.7 Perform the coolant flush procedure at the completion of a new engine break-in.

11.4 *New Engine Break-In*—A broad overview of the new engine break-in is as follows:

11.4.1 A minimum of 200 h of cyclical operation with BC oil is required. Hourly BSFC measurements are routinely recorded. The intense care for precision required for test operation is not required for cyclical break-in operation.

11.4.2 *Oil Charge for Break-in*—Service both oil filters to ensure that they are clean. Drain oil and charge the engine with 6.0 L (6.34 qt) of fresh BC oil. Use this oil charge for the entire new engine break-in.

11.4.3 *Break-in Operating Conditions*—Follow the break-in schedule for new engines as shown in Table 2. It is suggested that the cycling be a step function, rather than a ramp function. If a ramp function is used, take care to ensure that the ramp is not too mild, since too mild a ramp may not work the engine hard enough to successfully accomplish break-in.

11.4.4 *Stand Requirements for Break-in*—The engine break-in shall be done on a test stand that has a Midwest or Eaton 37 kW (50 hp) Model 758 dry gap dynamometer (see X1.4) and meets the specifications shown in Table 2.

11.5 *Routine Test Operation*—An overview of a non-reference oil test is as follows (r/min, kW, oil temperature °C):

11.5.1 Complete pre-test maintenance. A checklist for the maintenance is shown in Table A11.1.

11.5.2 Start engine.

11.5.3 Warm up to flush conditions with BC oil (see Table 4).

11.5.4 Double flush to BC oil.

11.5.4.1 Stabilize at Stage 1 (see Table 3) and acquire data for Stage 1.

11.5.4.2 Stabilize at Stage 2 (see Table 3) and acquire data at Stage 2.

11.5.4.3 Stabilize at Stage 3 (see Table 3) and acquire data at Stage 3.

11.5.4.4 Stabilize at Stage 4 (see Table 3) and acquire data at Stage 4.

11.5.4.5 Stabilize at Stage 5 (see Table 3) and acquire data at Stage 5.

11.5.4.6 Warm up to flush conditions with BC oil.

11.5.5 Double flush to non-reference oil.

11.5.5.1 Age 16-h at Stage Age at Phase I conditions (see Table 4).

11.5.5.2 Stabilize at Stage 1 (see Table 3) and acquire data at Stage 1.

- 11.5.5.3 Stabilize at Stage 2 (see Table 3) and acquire data at Stage 2.
- 11.5.5.4 Stabilize at Stage 3 (see Table 3) and acquire data at Stage 3.
- 11.5.5.5 Stabilize at Stage 4 (see Table 3) and acquire data at Stage 4.
- 11.5.5.6 Stabilize at Stage 5 (see Table 3) and acquire data at Stage 5.
- 11.5.6 Age 80 h at Stage Age Phase II conditions (see Table 4).
- 11.5.6.1 Stabilize at Stage 1 (see Table 3) and acquire data at Stage 1.
- 11.5.6.2 Stabilize at Stage 2 (see Table 3) and acquire data at Stage 2.
- 11.5.6.3 Stabilize at Stage 3 (see Table 3) and acquire data at Stage 3.
- 11.5.6.4 Stabilize at Stage 4 (see Table 3) and acquire data at Stage 4.
- 11.5.6.5 Stabilize at Stage 5 (see Table 3) and acquire data at Stage 5.
- 11.5.6.6 Warm up to flush conditions with test oil.
- 11.5.7 Detergent Flush (BCFHD) to BC.
- 11.5.7.1 Stabilize at Stage 1 (see Table 3) and acquire data at Stage 1.
- 11.5.7.2 Stabilize at Stage 2 (see Table 3) and acquire data at Stage 2.
- 11.5.7.3 Stabilize at Stage 3 (see Table 3) and acquire data at Stage 3.
- 11.5.7.4 Stabilize at Stage 4 (see Table 3) and acquire data at Stage 4.
- 11.5.7.5 Stabilize at Stage 5 (see Table 3) and acquire data at Stage 5.
- 11.5.7.6 Shutdown and perform necessary stand maintenance and equipment calibrations before continuing with next non-reference oil test.

11.5.8 *Start-Up and Shutdown Procedures*—In accomplishing a routine engine shutdown, disconnect the fuel lines or close the fuel valves for the fuel supply after the engine has been shut down. Remove the intake air supply duct.

11.5.8.1 *Unscheduled Shutdown and Restart*—There are no scheduled shutdown periods in the test. Continuous operation is expected from initial warm-up prior to flushing in the BC oil before test oil through the final testing of the BC oil segment after the test oil. If an unexpected shutdown does occur, the maximum allowable downtime per test is 10 h. Only four unscheduled shutdowns per test are allowed, and the maximum allowable downtime in any one unscheduled shutdown is 8 h. Report all shutdowns and the amount of time per shut down in the downtime occurrence section of the final report (Form 18). Report all other deviations in test time from Table 5 in the comment section of the final report (Form 18). Include details in these comments as to why the deviation occurred and the total time of the occurrence. If unexpected shutdowns occur, the following guidelines apply:

<p>Testing Phase During Stabilization Runs</p>	<p>Restart and Continuation Procedure Return to start of current step. Continue on existing schedule without deleting any of actual running stabilization time.</p>
--	---

During BSFC Measurement Runs

Reaccomplish the stabilization run in entirety and acquire all new BSFC data after the designated stabilization.

During Oil Flushes or During Test Oil Aging

Continue on existing schedule without deleting any of the prescribed operating time.

11.5.9 *Flying Flush Oil Exchange Procedures*—These flushing procedures involve oil exchanges without stopping the engine. In all cases, bring the engine to Stage Flush conditions (see Table 4) before initiating any flush. Flushing checklists are provided in Annex A5.

11.5.9.1 *Detergent Flush, Test Oil to BC Oil*—This procedure is intended to remove any residual effects from the previous oil and is performed when flushing from test oil to BC oil. A checklist for this detergent flush is shown in Table A5.1. Accomplish this detergent flush in the following steps:

(1) Heat the BCFHD oil and BC oil external reservoirs within the range of 93 to 107°C (199.4 to 224.6°F).

(2) Bring the engine to Stage Flush conditions (see Table 4).

(3) Switch external oil system (see Fig. A2.7 and 6.6) to Flush Mode and allow the engine to draw 6.0 L (6.34 qt) of BCFHD Oil while 6.0 L (6.34 qt) of oil is being scavenged from the oil sump. Note that the scavenge pump will draw oil from the oil sump until the oil level in the dump tank reaches the 6.0 L (6.34 qt) level and the float level switch in the dump tank turns off the scavenge pump. When the scavenge pump is turned off, the solenoids switch so that oil starts circulating to the engine as the oil sump fills to 6.0 L (6.34 qt). When the oil level in the sump reaches the full level (6.0 L/6.34 qt), the float level switch in the oil pan closes the solenoid to the oil reservoir and the oil then fully circulates to the engine.

(4) Allow the engine to continue running at Stage Flush conditions for 30 min.

(5) Reaccomplish Step 3 with BCFHD oil.

(6) Allow the engine to continue running at Stage Flush conditions for 2 h.

(7) With BC oil at the specified temperature for flushing, switch to the BC oil reservoir and accomplish Step 3 with BC (flush, fill, run).

(8) Allow the engine to continue running at Stage Flush conditions for 30 min.

(9) Reaccomplish Step 3 with BC oil.

(10) Allow the engine to continue running at Stage Flush conditions for 30 min.

(11) Reaccomplish Step 3 with BC oil.

(12) Return the engine to Stage 1 (see Table 3), and follow stabilization procedure for BSFC measurement with BC oil.

11.5.9.2 *Double Flush From BC Oil to Test Oil*—This procedure removes the previous oil and is performed when flushing from BC oil to test oil. A checklist for this double flush is shown in Table A5.2. This double flush is accomplished as follows:

(1) Heat the test oil in the external reservoir within the range of 93 to 107°C (199.4 to 224.6°F).

(2) Bring the engine to Stage Flush conditions.

(3) Switch the external oil system to Flush Mode and allow the engine to draw 6.0 L (6.34 qt) of non-reference oil while

6.0 L (6.34 qt) of oil is being scavenged from the oil sump. Note that the scavenge pump will draw oil until the level in the oil dump tank reaches the 6.0 L (6.34 qt) level and the float level switch in the dump tank turns off the scavenge pump. When the scavenge pump is turned off, the solenoids switch so that oil starts recirculating to the engine as the sump fills to 6.0 L (6.34 qt). When the oil level in the sump reaches the full level (6.0 L/6.34 qt), the float level switch in the oil pan closes the solenoid to the oil reservoir, and the oil fully recirculates to the engine.

- (4) Allow the engine to continue running at Stage Flush conditions for 30 min.
- (5) Reaccomplish Step 3
- (6) Allow the engine to continue running at Stage Flush conditions for 30 min.
- (7) Reaccomplish Step 3
- (8) Bring the engine to Stage Age Phase I conditions.
- (9) After completing the flush and when Stage Age Phase I conditions are met, add or drain oil to achieve the engine full level.

11.5.9.3 *Double Flush From BC Oil to BC Oil*—This procedure removes the previous oil and is performed when flushing from BC oil to BC oil between oil tests. A checklist for this double flush is shown in Table A5.3. Accomplish this double flush as follows:

- (1) Heat the BC oil in the external reservoir within the range of 93 to 107°C (199.4 to 224.6°F).

- (2) Bring the engine to Stage Flush conditions.
- (3) Switch the external oil system to Flush Mode and allow the engine to draw 6.0 L (6.34 qt) of BC oil while 6.0 L (6.34 qt) of BC oil is being scavenged from the oil sump. Note that the scavenge pump will draw oil until the level in the oil dump tank reaches the 6.0 L (6.34 qt) level and the float level switch in the dump tank turns off the scavenge pump. When the scavenge pump is turned off, the solenoids switch so that oil starts recirculating to the engine as the sump fills to 6.0 L (6.34 qt). When the oil level in the sump reaches the full level 6.0 L (6.34 qt), the float level switch in the oil pan closes the solenoid to the oil reservoir, and the oil fully recirculates to the engine.
- (4) Allow the engine to continue running at Stage Flush conditions for 30 min.
- (5) Reaccomplish Step 3
- (6) Allow the engine to continue running at Stage Flush conditions for 30 min.
- (7) Reaccomplish Step 3
- (8) Return the engine to Stage 1, and follow the stabilization procedure for BSFC measurement with BC oil.

11.5.10 *Test Operating Stages*—Table 3 depicts the test operating conditions for the stages, Table 5 depicts the schedule of operation, and Fig. 1 depicts the method of obtaining fuel flows and BSFC's for results comparison.

11.5.10.1 After an engine has been broken in and deemed an acceptable stand/engine combination by TMC, evaluate non-reference oils relative to BC oil. This entails comparing the

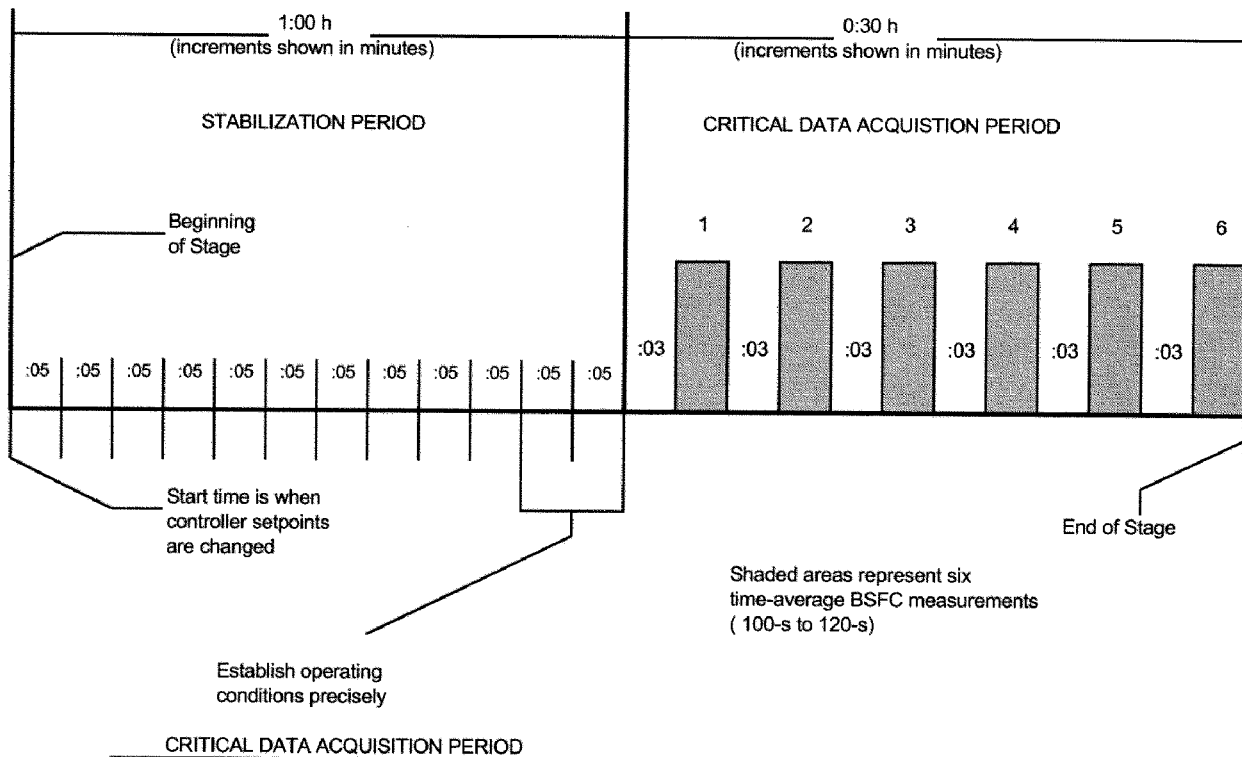

Obtain 6 BSFC readings at 5-min intervals over a total period of 30-min. The final 100 to 120-s is for obtaining the BSFC data.

FIG. 1 Data Acquisition Period

total fuel consumed (mass) for aged (16 and 80 h) test oil run at the five stages with that of the fresh BC oil run before and after the test oil.

11.5.11 Stabilization to Stage Conditions—After the flying flush to each oil (BC or test oil) and for the change to each stage, a stabilization time of 1 h is specified prior to beginning the BSFC measurement cycle. This time is that which elapses between initially changing the speed/load/temperature set points and the beginning of the first BSFC measurement cycle for that stage. It, therefore, includes the time during which the temperatures are changing. Manage the speed, load, coolant, and oil temperature control loops such that the processes are brought to the desired set points expeditiously.

11.5.12 Stabilized BSFC Measurement Cycle—After the stabilization period (1 h) has elapsed for each stage, run a series of 6 BSFC measurements by the cycle which is described in Fig. 1. During this 30-min period control the operating conditions for all of the critical parameters as shown in Table 3. During the BSFC measurement cycle of a test, any stage may only be restarted one time provided the sixth reading of the stage has not been completed. Additionally, if the sixth reading of any stage is completed and a critical parameter average is out of the specified range, that stage cannot be rerun and the test is considered invalid. A minimum of 100 data points are required for speed, load, fuel flow rate, and AFR for integration during each six of the approximate 2-min (100 to 120-s) data sample intervals. A minimum of a single snap shot reading of each of the other parameters shown in Table 3 shall be taken during each 100 to 120 data sample period. BSFC is calculated for each of the five stages as follows:

$$\frac{(\text{Integrated Fuel Flow}) (9549.3)}{(\text{Integrated Load}) \times (\text{Integrated Speed})} = \text{BSFC in kg/kW}\cdot\text{h} \quad (3)$$

where:

Integrated Speed = (r/min) to one decimal place,
 Integrated Load = (N·m) to two decimal places,
 and
 Integrated Fuel Flow Rate = (kg/h) to three decimal places.

11.5.12.1 Calculate BSFC measurements as in Eq 3 for each of the six steps in each stage to four decimal places and record after rounding (see Practice E 29) the average for each stage to five decimal places. Calculate the coefficient of variation (C.V.) of the six BSFC determinations. Due to the low engine operating speed and low fuel consumption in Stages 2 and 3, it is recognized that the C.V. for these Stages may tend to be higher than for Stages 1, 4, and 5.

(1) A test cannot be deemed operationally invalid for high C.V. alone.

11.5.13 Data Logging—Use of manual data logs is optional.

11.5.14 BC Oil Flush Procedure for BC Oil Before Test Oil—At the start of test, warm the engine to Stage Flush conditions (see Table 4) and flush the BC oil into the engine without shutting the engine down. The sequence of events for this flush are as follows (see 11.5.9.2 and Table A5.3):

11.5.14.1 Warm engine to Stage Flush.

11.5.14.2 Double flush to BC oil.

11.5.14.3 Proceed with BC oil BSFC data acquisition.

11.5.15 BSFC Measurement of BC Oil Before Test Oil—Run Stages 1 through 5 as detailed in Table 3. Obtain 6 BSFC measurements at each stage according to the Critical Data Acquisition Period as detailed in Fig. 1 and 11.5.12.

11.5.15.1 When six data points have been obtained at Stage 1, calculate the coefficient of variation (C.V.) for the mean BSFC of the six runs.

11.5.16 Test Oil Flush Procedure—After the BC oil before test oil segment is completed, flush the test oil into the engine without shutting the engine down. The sequence of events for this flush are as follows (see 11.5.9.2 and Table A5.2):

11.5.16.1 Double flush to test oil.

11.5.16.2 Proceed with test oil aging.

11.5.17 Test Oil Aging—Run the initial 16 h of aging at the conditions shown in Table 4, Phase I. This 16-h interval starts when the double flush procedure is completed. The maximum allowable off-test-time during Phase I Aging is 2 h. If off-test time exceeds 2 h, the test is invalid. At the completion of the Phase I aging, run the first of two fuel economy measurements on the test oil.

11.5.17.1 Oil Consumption During Aging—Monitor test oil consumption during the 16-h aging period by observing the running oil level in the engine oil sight glass. At the completion of the test oil flush to Phase I aging, adjust the oil level to the full mark. No oil additions are allowed after the first hour of aging.

11.5.18 BSFC Measurement of Aged (Phase I) Test Oil—After Aging Phase I (16 h) has completed run Stages 1 through 5 as detailed in Table 3. Obtain 6 BSFC measurements at each stage according to the Critical Data Acquisition Period as detailed in Fig. 1 and 11.5.12.

11.5.19 Aging Phase II—At the completion of this fuel economy measurement (11.5.18) the test condition shall precede to Aging Phase II conditions shown in Table 4. Aging Phase II is complete when 80 h have been run at these conditions. The maximum allowable off-test-time during Phase II Aging is 2 h. If off-test time exceeds 2 h, the test is invalid.

11.5.20 Oil Consumption and Sampling—Once the test has stabilized in Stage No. 1 (oil/coolant temperatures) of the second fuel economy measurement (after completion of Aging Phase II), record the oil level. The maximum allowable oil consumption for reference and non-reference oil tests is 1900 mL (65 oz). If the reference or non-reference test exceeds 1900 mL (65 oz), the test is invalid. After recording the oil level, take a 120-mL (4-oz) sample from the outlet (top) of the oil heater for viscosity measurement (see 13.2.10).

11.5.21 BSFC Measurement of Aged (Phase II) Test Oil—After Aging Phase II (80 h) has completed run Stages 1 through 5 as detailed in Table 3. Obtain 6 BSFC measurements at each stage according to the Critical Data Acquisition Period as detailed in Fig. 1 and 11.5.12.

11.5.22 BC Oil Flush Procedure for BC Oil After Test Oil—After the test oil segment of the test is completed, flush BCFHD oil into the engine without shutting the engine down.

11.5.22.1 BCFHD (detergent flush) to BC oil.

11.5.22.2 Proceed with BC oil BSFC data acquisition.

11.5.23 BSFC Measurement of BC Oil After Test Oil—Run Stages 1 through 5 as detailed in Table 3. Obtain 6 BSFC

measurements at each stage according to the Critical Data Acquisition Period as detailed in Fig. 1 and 11.5.12. When the BC After Test Oil is completed, calculate the BC shift as follows:

Reference Test: $((RBC1KG-RBC2KG) \div RBC1KG) \times 100$
(See Form 4)

Non-Reference Test: $((BC1KG-BC2KG) \div BC1KG) \times 100$
(See Form 4)

11.5.24 *General Test Data Logging Forms*—Utilize the report format shown in Annex A7.

11.5.25 *Diagnostic Review Procedures*—To ensure test operational validity, a critical review the data at frequent intervals during the test is recommended. The final review after the test is completed is only partially effective in identifying problems, since the indicated data cannot be cross examined by first hand observation. Early detection of instrumentation errors is essential and often the record for information parameters (dependent variables) indicate problem areas involving the primary control parameters. The following parameter response characteristics are significant:

- 11.5.25.1 Stabilization trends,
- 11.5.25.2 Air fuel ratio stability,
- 11.5.25.3 Fuel flow stability,
- 11.5.25.4 Intake manifold vacuum/absolute pressure,
- 11.5.25.5 Speed,
- 11.5.25.6 Load, and
- 11.5.25.7 Exhaust back pressure.

11.5.26 *Total Test Length*—Total test length for reference and non-reference oil tests cannot exceed 150 h. Tests exceeding 150 h, are invalid.

12. Determination of Test Results

12.1 FEI1 and FEI2 Calculations:

- 12.1.1 Calculate the test results as detailed in Table 6.

13. Final Test Report

13.1 *Validity Statement*—Include a statement pertaining to the validity of the test at the bottom of the Report Title Page (Form 1) which is signed by the person responsible for conducting the test.

13.2 *Report Format*—For reference oil tests, the standardized report form set and data dictionary for reporting test results and for summarizing the operational data are required. The standard ASTM Sequence VIB Test Report forms are shown in Annex A7.

13.2.1 *BC Before Start Date*—The BC before start date is defined as the date when the BC before test oil flush enters into the engine.

13.2.2 *BC Before Start Time*—The BC before start time is defined as the time when the BC before test oil flush enters into the engine.

13.2.3 *Test Oil Start Date*—This is defined as the date when the first non-reference or reference test oil flush enters into the engine.

13.2.4 *Test Oil Start Time*—This is defined as the time when the first non-reference or reference test oil flush enters into the engine.

13.2.5 *BC After Test Oil Start Date*—The BC after test oil start date is defined as the date when the BCDFH test oil flush enters into the engine.

13.2.6 *BC After Test Oil Start Time*—The BC after test oil start time is defined as the time when the BCDFH test oil flush enters into the engine.

13.2.7 *Total Engine Hours at End of Test*—This is defined as the cumulative engine hours at the completion of BC After Test Oil.

13.2.8 *Total Test Length*—This is defined as the total test hours accumulated from the BC before start time/date through the completion of BC After Test Oil Stage 5.

13.2.9 *Fuel Batch*—This is defined as the batch number for the most recent batch of fuel which has been put into the fuel tank (it is recognized that in most cases a fuel tank will not be completely empty before a new load of fuel is put into the tank, so the fuel in the tank may actually be a mixture of two or more batches).

13.2.10 *Oil Viscosity Measurement*—Measure and report viscosity determinations at 40°C and 100°C (Form 4) for New Oil and for Aged (Phase II) Oil. Make the viscosity determinations according to Test Method D 445.

13.2.11 *Use of SI Units*—Report all results in (SI) units. Follow the rules for conversion of inch-pound units to SI units as described in IEEE/ASTM SI-10.

13.2.12 *Precision of Reported Units*—Use Practice E 29 for rounding off data. Use the rounding-off method to report data to the required precision.

13.3 *Data Dictionary*—The Data Dictionary is available from the TMC (see Annex A7).

13.4 *Off-Test-Time*—This is defined as the time when the test is not operating at the scheduled test conditions, but shutting down the engine is not required.

14. Precision and Bias

14.1 *Precision*—Test precision is established on the basis of reference oil test results (for operationally-valid tests) monitored by the TMC. The data are reviewed semi-annually by the Sequence VI/VIB Surveillance Panel. Contact the TMC for current industry data. Precision data for non-reference oils are reviewed semi-annually by the ASTM Sequence VIB Surveillance Panel.

14.1.1 Test precision as established for the official acceptance of this procedure is shown in Table 8.

NOTE 7—Contact the TMC for up-to-date data.

14.1.2 *Intermediate Precision (formerly called repeatability) Conditions*—Conditions where test results are obtained with the same test method using the same test oil, with

TABLE 8 Sequence VIB Reference Oil Precision Statistics^A

Variable	Intermediate Precision		Reproducibility	
	s _{i.p.} ^B	i.p.	S _R ^B	R
Fuel Economy Improvement, %				
at 16 h	0.22	0.616	0.24	0.672
at 80 h	0.21	0.588	0.25	0.700

^A These statistics are based on results obtained on Test Monitoring Reference Oils 1006, 1007, and 1008.

^B s = standard deviation.

changing conditions such as operators, measuring equipment, test stands, test engines, and time.

14.1.2.1 *Intermediate Precision Limit (i.p.)*—The difference between two results obtained under intermediate precision conditions that would in the long run, in the normal and correct conduct of the test method, exceed the values shown in Table 8 in only one case in twenty.

14.1.3 *Reproducibility Conditions*—Conditions where test results are obtained with the same test method using the same test oil in different laboratories with different operators using different equipment.

14.1.3.1 *Reproducibility Limit (R)*—The difference between results obtained under reproducibility conditions that would, in the long run, in the normal and correct conduct of the test method, exceed the values in Table 8 in only one case in twenty.

14.2 *Validity*—The following guidelines provide a basis for judgements regarding the validity or validity of test results. The TMC administers reference test requirements utilizing these and other guidelines. The results are valid only when all details of the procedure are followed and when the test is conducted on a TMC calibrated test stand. Good engineering practice shall be followed in all aspects of the test procedure. Unexpected deviation in the controlled test parameters are to be judged according to the applicable guidelines established in 14.2.2. Beyond these guidelines, good engineering judgement shall be applied in all unforeseen circumstances to protect the validity of the test results. If anomalies exist within the data generated during a test and are not addressed within this procedure, they shall be documented in the test report (Form 18).

14.2.1 *Test Stand Calibration Status*—The essential requirements of 10.1 provide the basis for official recognition of test stand calibration.

14.2.2 *Validity Interpretation of Deviant Operational Conditions*—In the general case, engineering judgement at the laboratory governs the validity acceptance of tests having deviant operational history. The TMC is involved in this process for tests conducted using reference oils and is available for consultation for tests conducted on non-reference oils. Averages of critical parameters (speed, load, exhaust back pressure, engine oil gallery temperature, engine coolant in temperature, intake air temperature, fuel to fuel rail temperature, and AFR), taken as sets of six 5-min readings at test Stages 1 through 5 which do not meet procedural specifications, will invalidate a test if the BSFC values from such deviant blocks of data are used in the final computation of the results. Excursions during the six passes which make up the average are acceptable as long as the average is within procedural limits.

14.3 *Bias*—Bias is determined by applying an acceptable statistical technique to reference oil test results and when a significant bias is determined, a severity adjustment is permitted for non-reference oil test results.

15. Keywords

15.1 aged test oil; brake specific fuel consumption; break-in; calibration oil; flying flush; fuel economy; reference oil; sequence VIB; spark-ignition automotive engine

ANNEXES

(Mandatory Information)

A1. THE ROLE OF THE ASTM TEST MONITORING CENTER AND THE CALIBRATION PROGRAM

A1.1 Nature and Functions of the ASTM Monitoring Center (TMC)

A1.1.1 The TMC³ is a non-profit organization located in Pittsburgh, Pennsylvania and is staffed to administer engineering studies; conduct laboratory visits; perform statistical analyses of reference oil test data; blend, store, and ship reference oils; and provide the associated administrative functions to maintain the referencing calibration program for various lubricant tests as directed by Subcommittee D02.B and the Test Monitoring Board. The TMC coordinates its activities with the test sponsors, the test developers, the surveillance panels, and the testing laboratories.

A1.2 Rules of Operation of the ASTM TMC

A1.2.1 The TMC operates in accordance with the ASTM Charter, the ASTM Bylaws, the Regulations Governing ASTM Technical Committees, the Bylaws Governing ASTM Committee D02, and the Rules and Regulations Governing the ASTM Test Monitoring System.

A1.3 Management of the ASTM TMC

A1.3.1 The management of the Test Monitoring System is vested in the Test Monitoring Board (TMB) elected by Subcommittee D02.B. The TMB selects the TMC Administrator who is responsible for directing the activities of the TMC staff.

A1.4 Operating Income of the ASTM TMC

A1.4.1 The TMC operating income is obtained from fees levied on the reference oils supplied and on the calibration tests conducted. Fee schedules are established and reviewed by Subcommittee D02.B.

A1.5 Conducting a Reference Oil Test

A1.5.1 For those laboratories which choose to utilize the services of the TMC in maintaining calibration of test stands, full-scale calibration testing shall be conducted at regular intervals. These full-scale tests are conducted using coded reference oils supplied by the TMC. It is a laboratory's

responsibility to keep the on-site reference oil inventory at or above the minimum level specified by the TMC test engineers.

A1.5.2 When laboratory personnel decide to run a reference calibration test, they shall request an oil code from the cognizant TMC engineer. Upon completion of the reference oil test, the data shall be sent in summary form (use TMC-acceptable forms) to the TMC by telephone facsimile transmission, or some other method acceptable to the TMC. The TMC will review the data and contact the laboratory engineer to report the laboratory's calibration status. All reference oil tests, whether aborted, invalidated, or successfully completed, shall be reported to the TMC. Subsequent to sending the data in summary form to the TMC, the laboratory is required to submit to the TMC the written test report specified in the test method.

A1.6 New Laboratories

A1.6.1 Laboratories wishing to become part of the ASTM Test Monitoring System will be requested to conduct reference oil tests to ensure that the laboratory is using the proper testing techniques. Information concerning fees, laboratory inspection, reagents, testing practices, appropriate committee membership, and rater training can be obtained by contacting the TMC Administrator at:

ASTM Test Monitoring Center
6555 Penn Avenue
Pittsburgh, PA 15206-4489

A1.7 Introducing New Sequence VIB Reference Oils

A1.7.1 The calibrating reference oils produce various fuel economy results. When new reference oils are selected, member laboratories will be requested to conduct their share of tests to enable the TMC to establish the proper industry average and test acceptable limits. The ASTM D02.B0.01 Sequence VIB Surveillance Panel will require a minimum number of tests to establish the industry average and test acceptance targets for new reference oils.

A1.8 TMC Information Letters

A1.8.1 Occasionally it is necessary to change the procedure, and notify the test laboratories of the change, prior to consideration of the change by either Subcommittee D02.B0 on Automotive Lubricants, or ASTM Committee D02 on Petroleum Products and Lubricants. In such a case, the TMC will issue an Information Letter. Information Letters are balloted by

Subcommittee D02.B0. By this means, the Society due process procedures are applied to these Information Letters.

A1.8.2 The review of an Information Letter prior to its original issue will differ according to its nature. In the case of an Information Letter concerning a part number change which does not affect test results, the TMC is authorized to issue such a letter. Long-term studies by the Surveillance Panel to improve the test procedure through improved operation and hardware control may result in a recommendation to issue an Information Letter. If obvious procedural items affecting test results need immediate attention, the test sponsor and the TMC will issue an Information Letter and present the background and data to the Surveillance Panel for approval prior to the semiannual Subcommittee D02.B0 meeting.

A1.8.3 Authority for the issuance of Information Letters was given by the committee on Technical Committee Operations in 1984, as follows: "COTCO recognizes that D02 has a unique and complex situation. The use of Information Letters is approved providing each letter contains a disclaimer to the effect that such has not obtained ASTM consensus. These Information Letters should be moved to such consensus as rapidly as possible."

A1.8.4 Information Letters pertaining to this procedure issued prior to 02-1 are incorporated into this test method. A listing of such Information Letters, and copies of the letters, may be obtained from the TMC. Information Letters issued subsequent to this date may also be obtained from the TMC.

A1.9 TMC Memoranda

A1.9.1 In addition to the aforementioned Information Letters, supplementary memoranda are issued. These are developed by the TMC, and distributed to the Sequence VIB Surveillance Panel and to participating laboratories. They convey such information as batch approvals for test parts or materials, clarification of the test procedure, notes and suggestions of the collection and analysis of special data that the TMC may request, or for any other pertinent matters having no direct effect on the test performance, results, or precision and bias.

A1.10 Precision Data

A1.10.1 The TMC determines the current Sequence VIB test precision by analyzing results of calibration tests conducted on reference oils. Current precision data can be obtained from the TMC.

A2. DETAILED SPECIFICATIONS AND DRAWINGS OF APPARATUS

A2.1 Fig. A2.1 through Fig. A2.24 present the detailed specifications and drawings of apparatus.¹³

¹³ The sole source of supply of the SS fittings known to the committee at this time is Arthur Valve & Fitting Company, 5402 Grissom Road, San Antonio, TX 78238. If you are aware of alternative suppliers, please provide this information to ASTM International Headquarters. Your comments will receive careful consideration at a meeting of the responsible technical committee,¹ which you may attend.

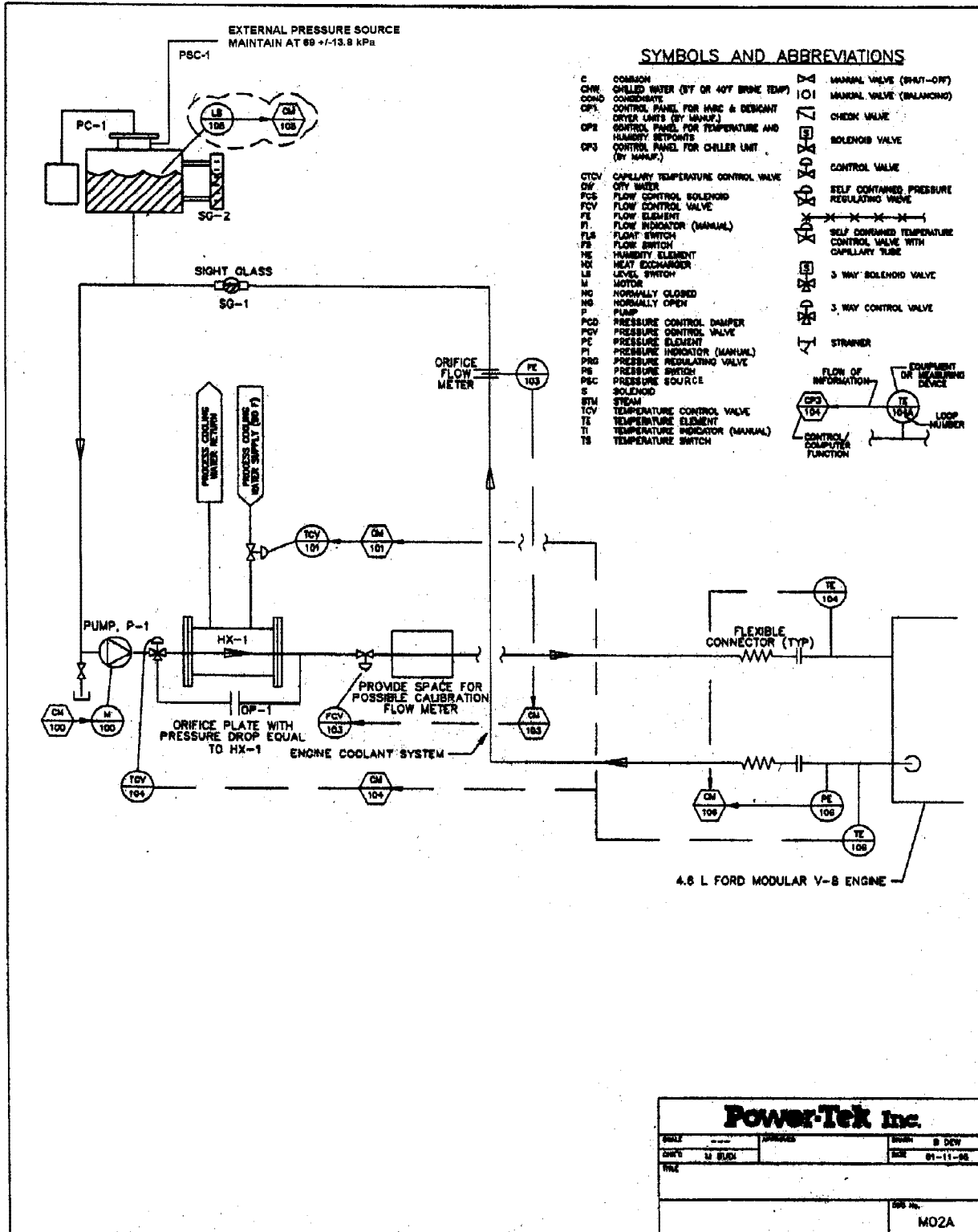

FIG. A2.1 Engine Cooling System

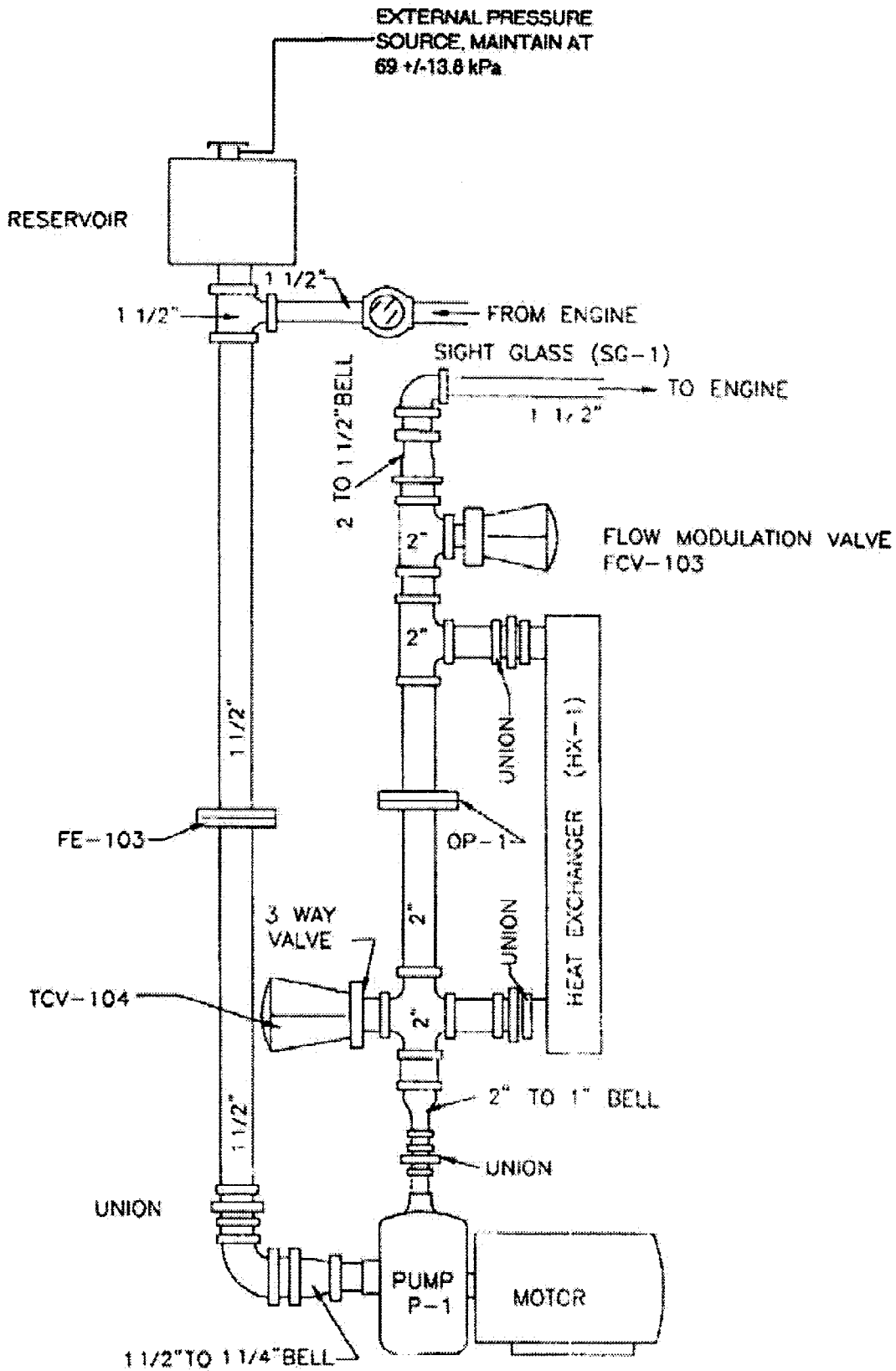

FIG. A2.2 Typical Engine System in Air-To-Close Configuration

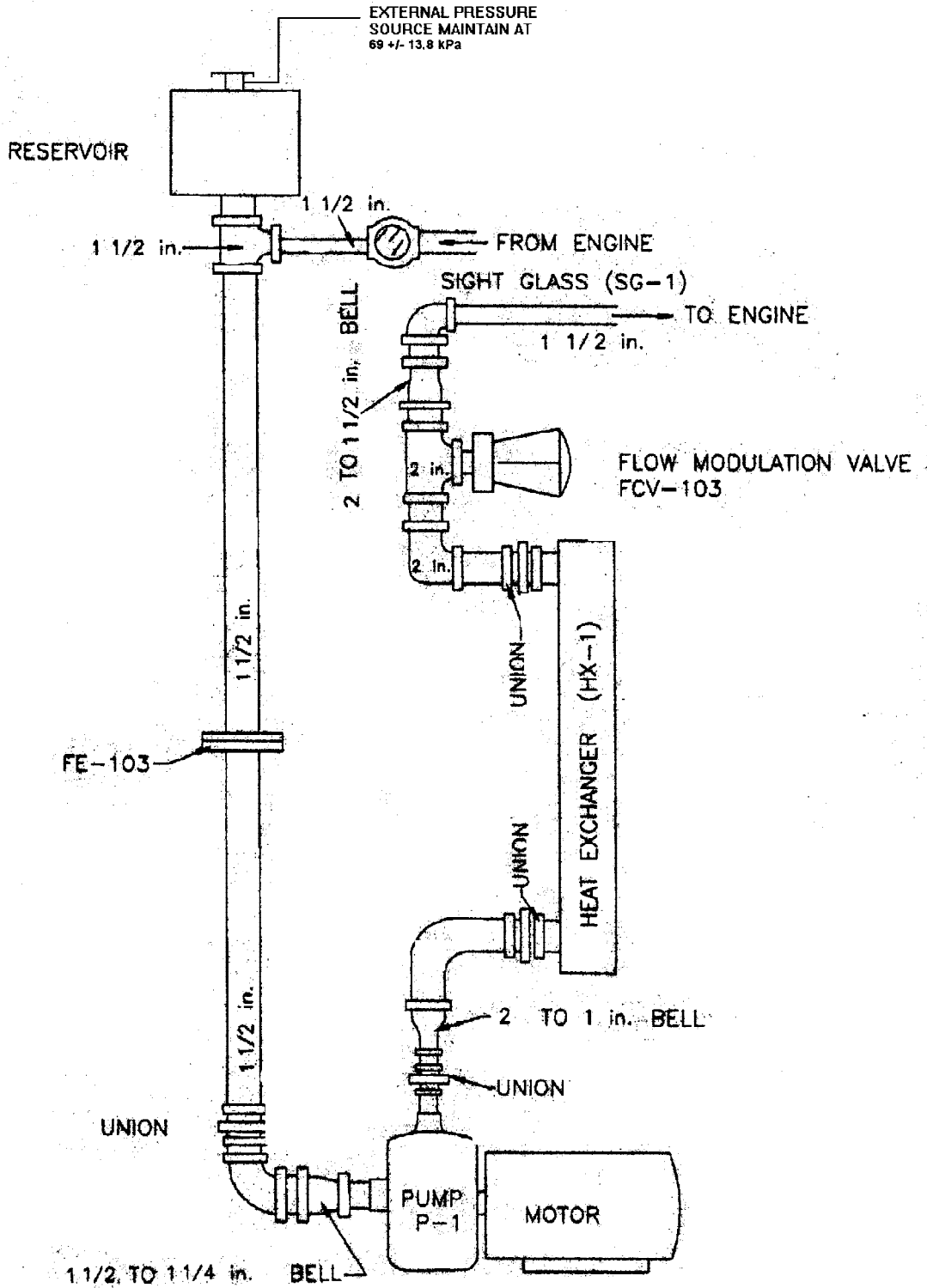
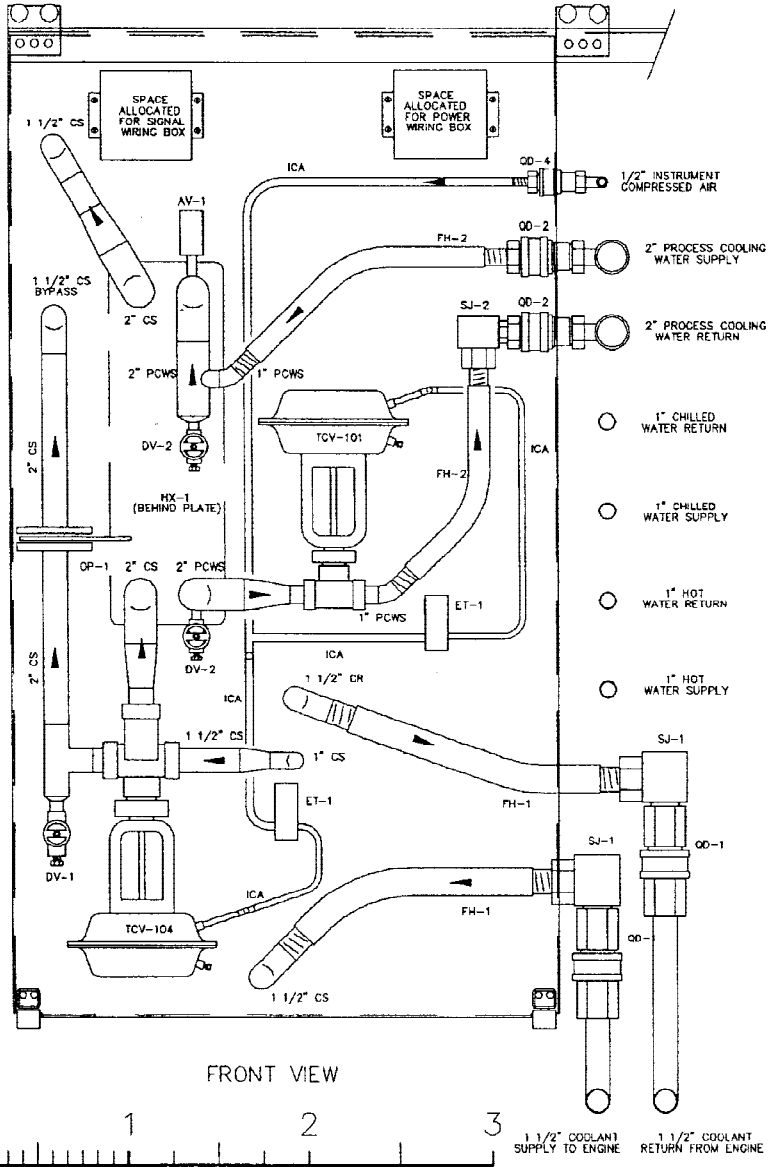

FIG. A2.3 Alternative Engine System Configuration

NOTES:

1. AIR VENTS SHOWN ARE OPTIONAL AND AT THE DISCRETION OF THE OWNER. IF AIR VENTS ARE NOT USED, PROVIDE AN EXTRA SET OF DISCONNECTS FOR USE IN OPENING THE INTERNAL SHUT-OFF VALVE OF THE QUICK DISCONNECT (WHEN DRAINING THE SYSTEM)



FRONT VIEW



SCALE IN FT

Power-Tek Inc.			
SCALE	---	APPROVED	DRAWN B DEW
CHK'D M BUDI			DATE 01-11-95
TITLE			FIGURE 4
DWS No.			M11A

FIG. A2.4 Engine Cooling System (Front View)

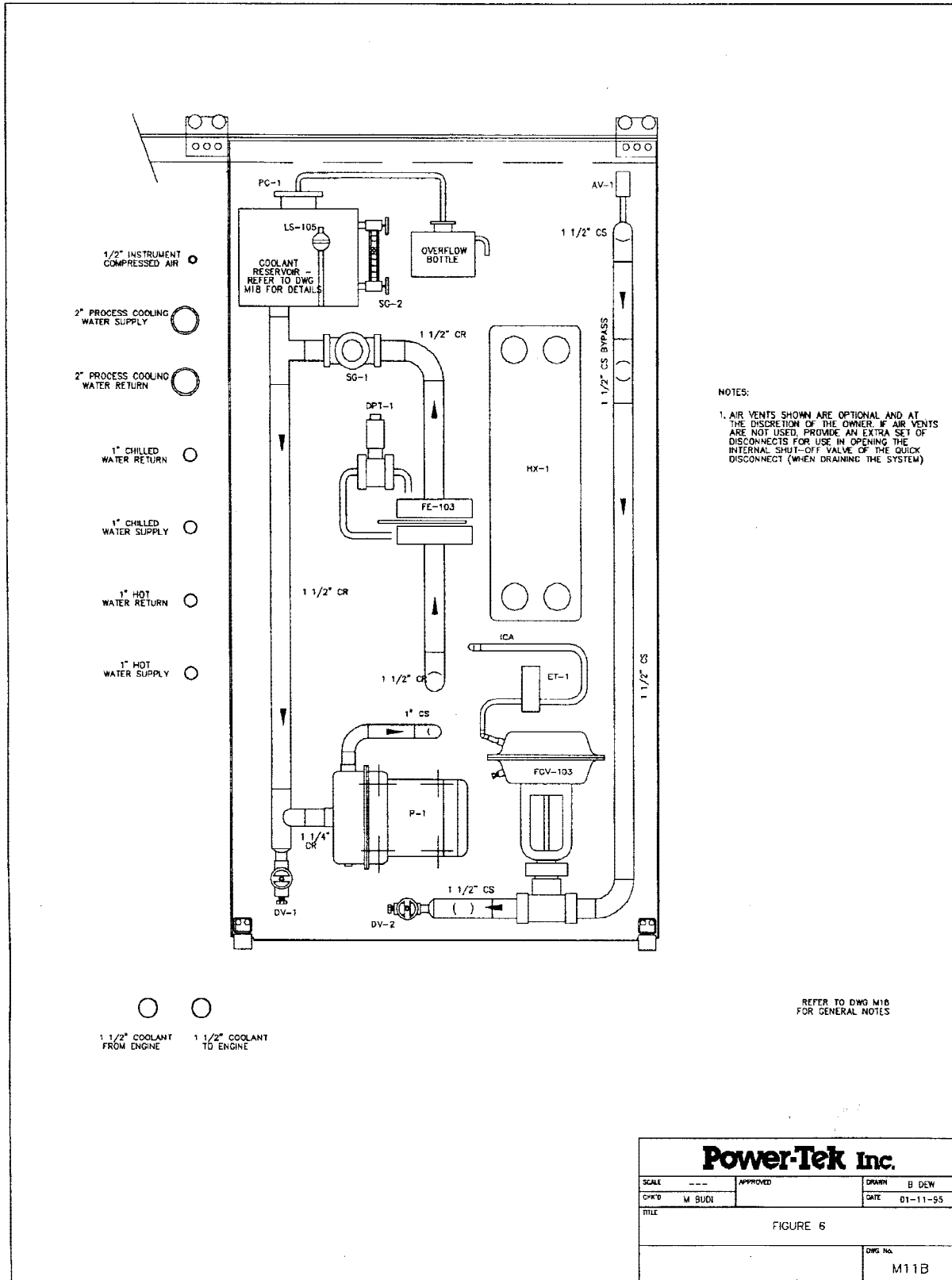

FIG. A2.5 Engine Cooling System (Back View)

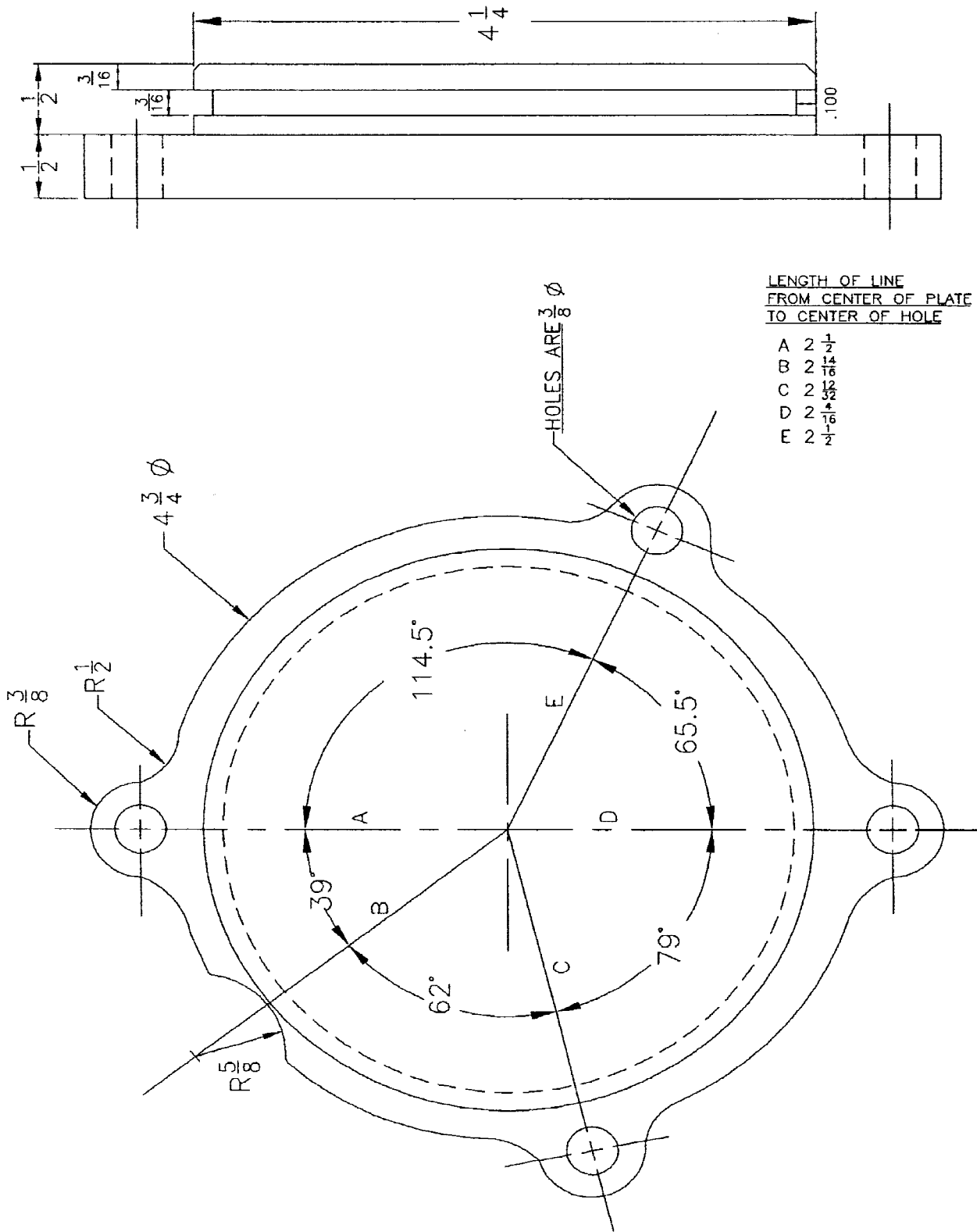

FIG. A2.6 Water Pump Plate

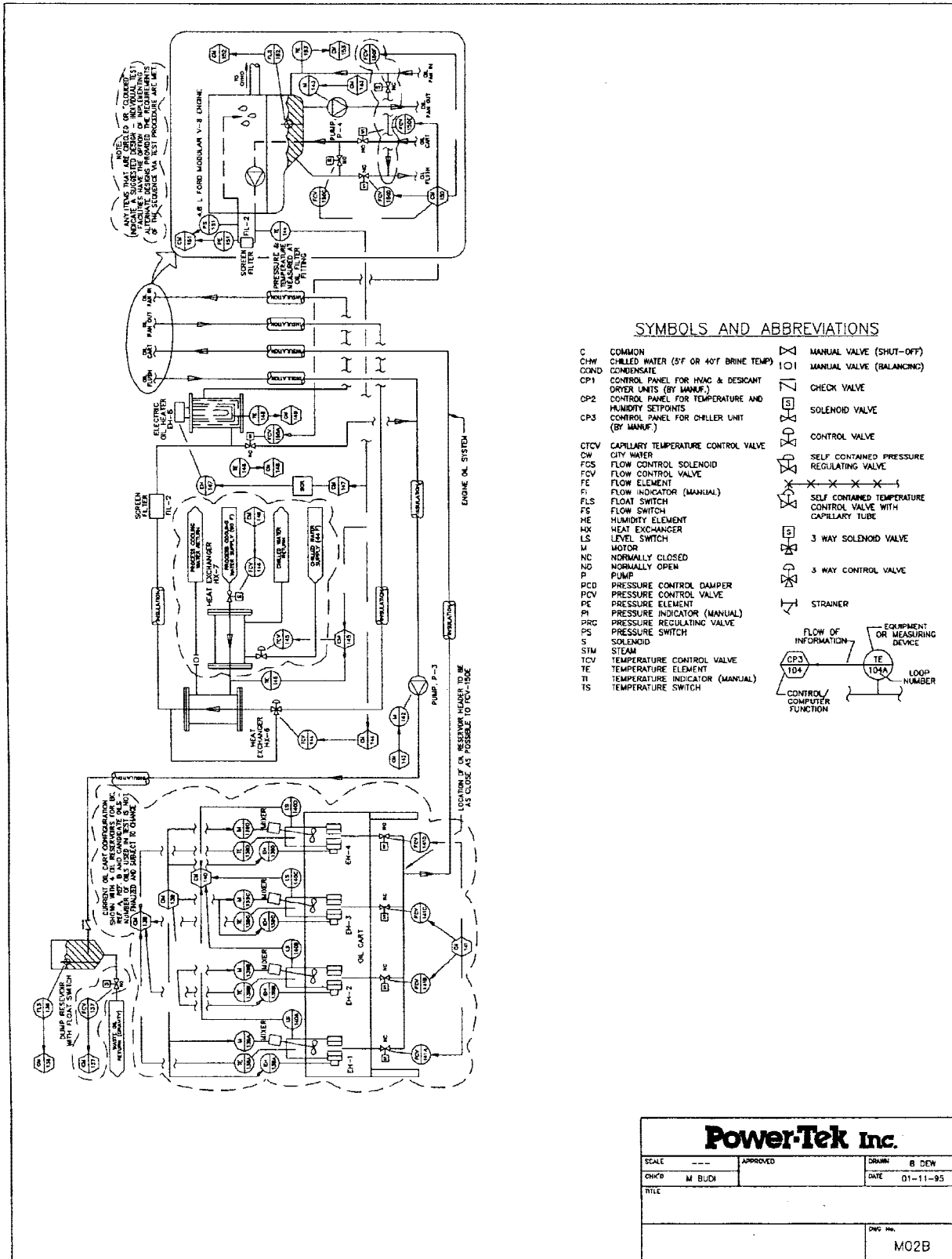

FIG. A2.7 External Oil System

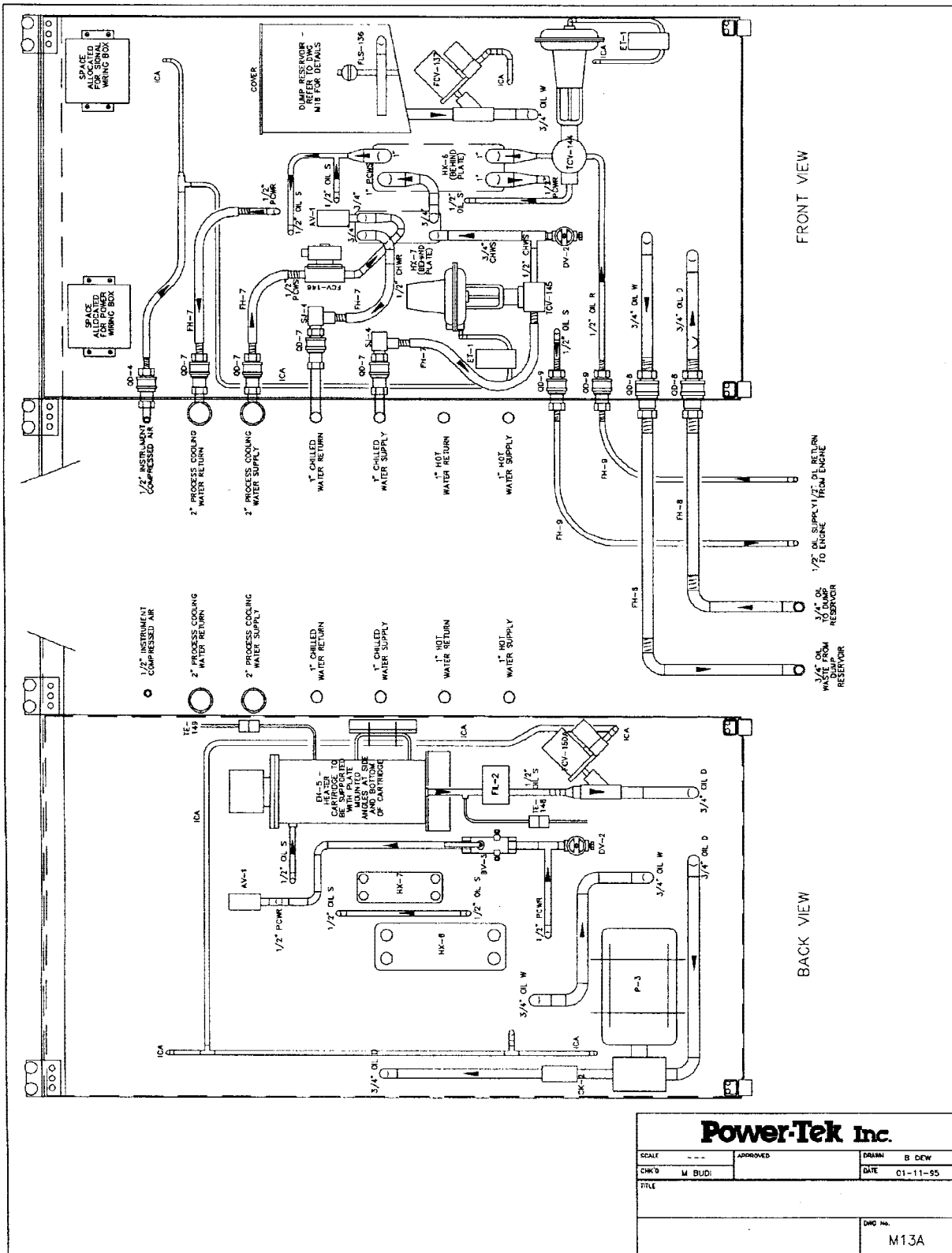
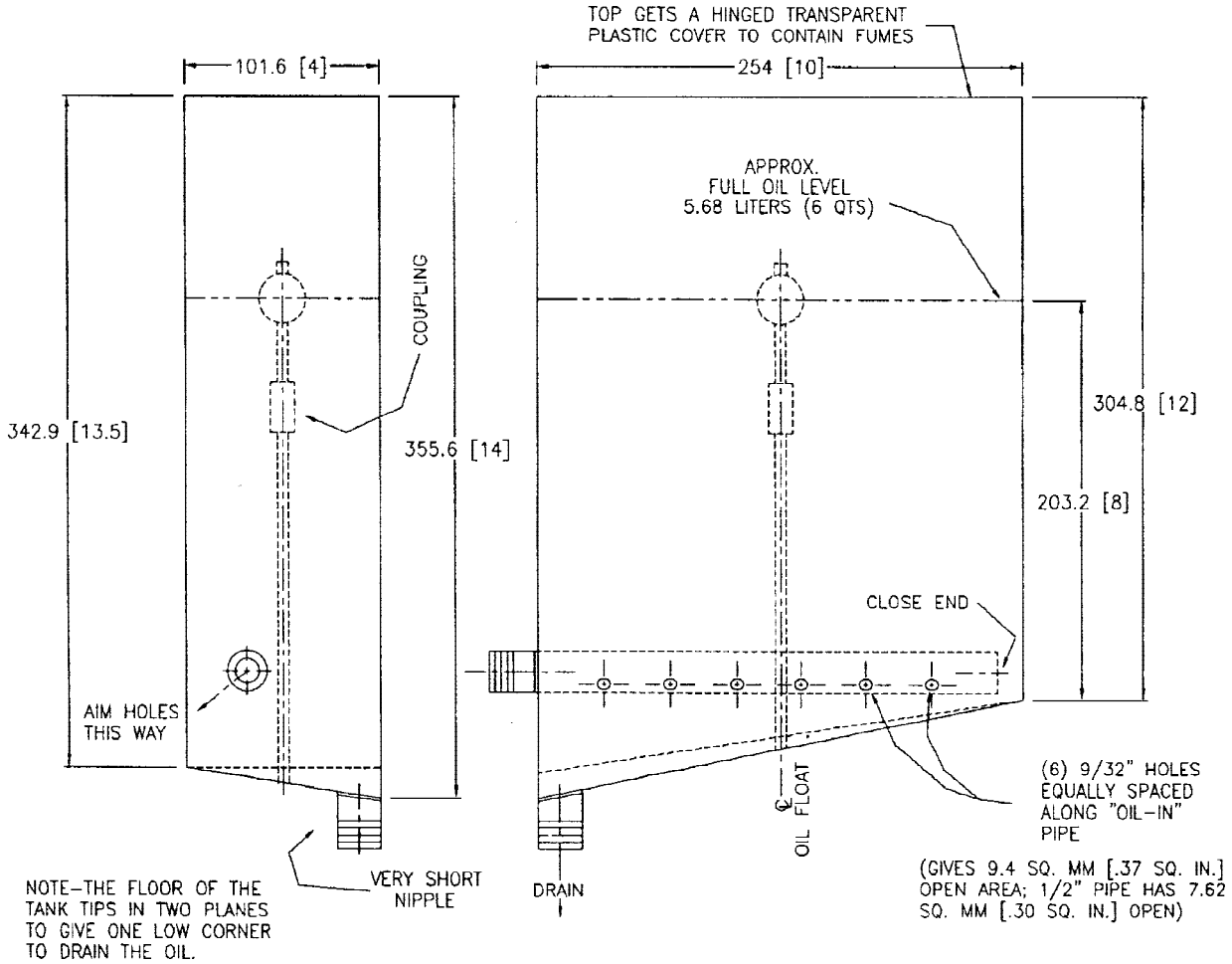

FIG. A2.8 External Oil System (Front and Back)

FOLD FROM ABOUT 1.27 [.05] TO 1.52 [.06] STAINLESS STEEL & WELD ALL JOINTS SO CONTAINER HOLDS LIQUID



"OIL-IN" BLACK 1/2" PIPE, "OIL DRAIN" SHORT 1/2" NIPPLE

NOTE-DIMENSIONS ARE IN MILLIMETERS AND [INCHES]

STAND PIPE TO HOLD FLOAT SWITCH IS 1/4" PIPE; USE A SHORT NIPPLE OF SELECTED LENGTH BETWEEN FLOAT SWITCH AND 1/4" COUPLING TO GET EXACT LEVEL NEEDED TO TRIP SWITCH AT 5.68 LITERS (6 QTS.).

TANK IS LATER MOUNTED BY TACK WELDING AN ANGLE IRON LEG ALONG ONE OF THE VERTICAL CORNERS AND WELDING A SQUARE PLATE AT THE BOTTOM OF THE LEG, WHICH CAN BE BOLTED TO THE FLOOR OR OTHER HORIZONTAL SURFACE

FIG. A2.9 Typical Oil Dump Tank

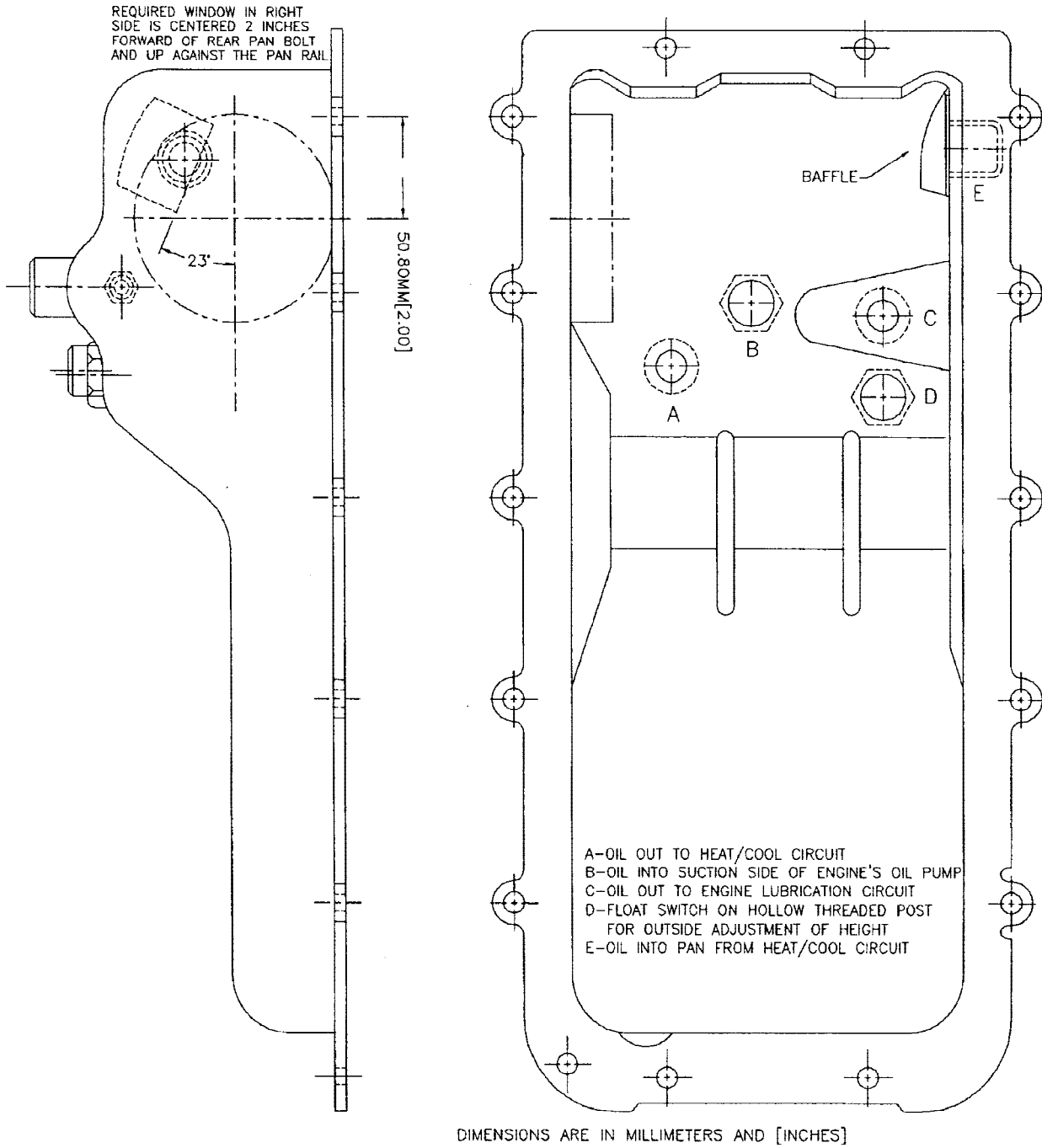

FIG. A2.10 Sequence VIB Pan Modifications

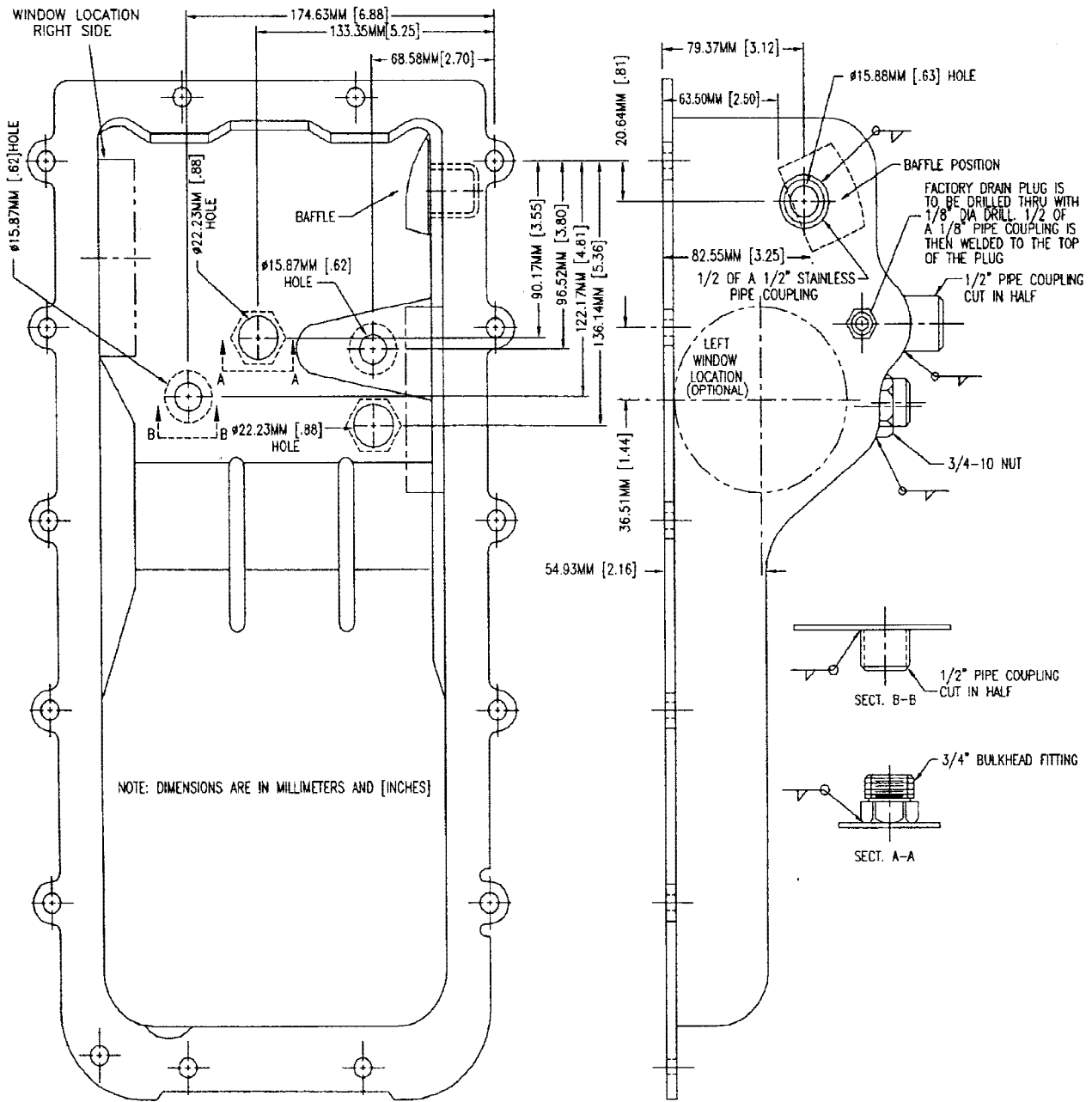
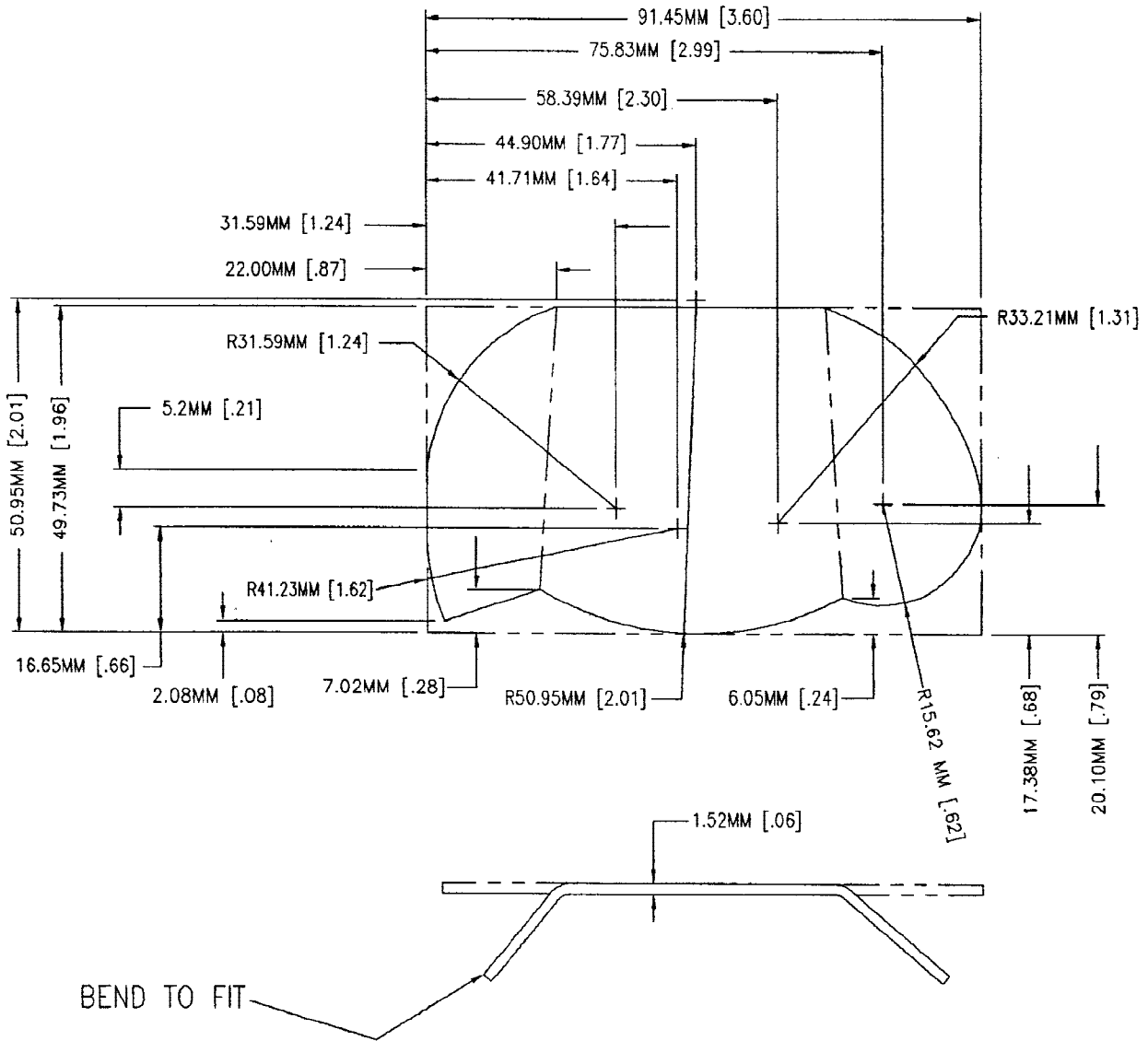
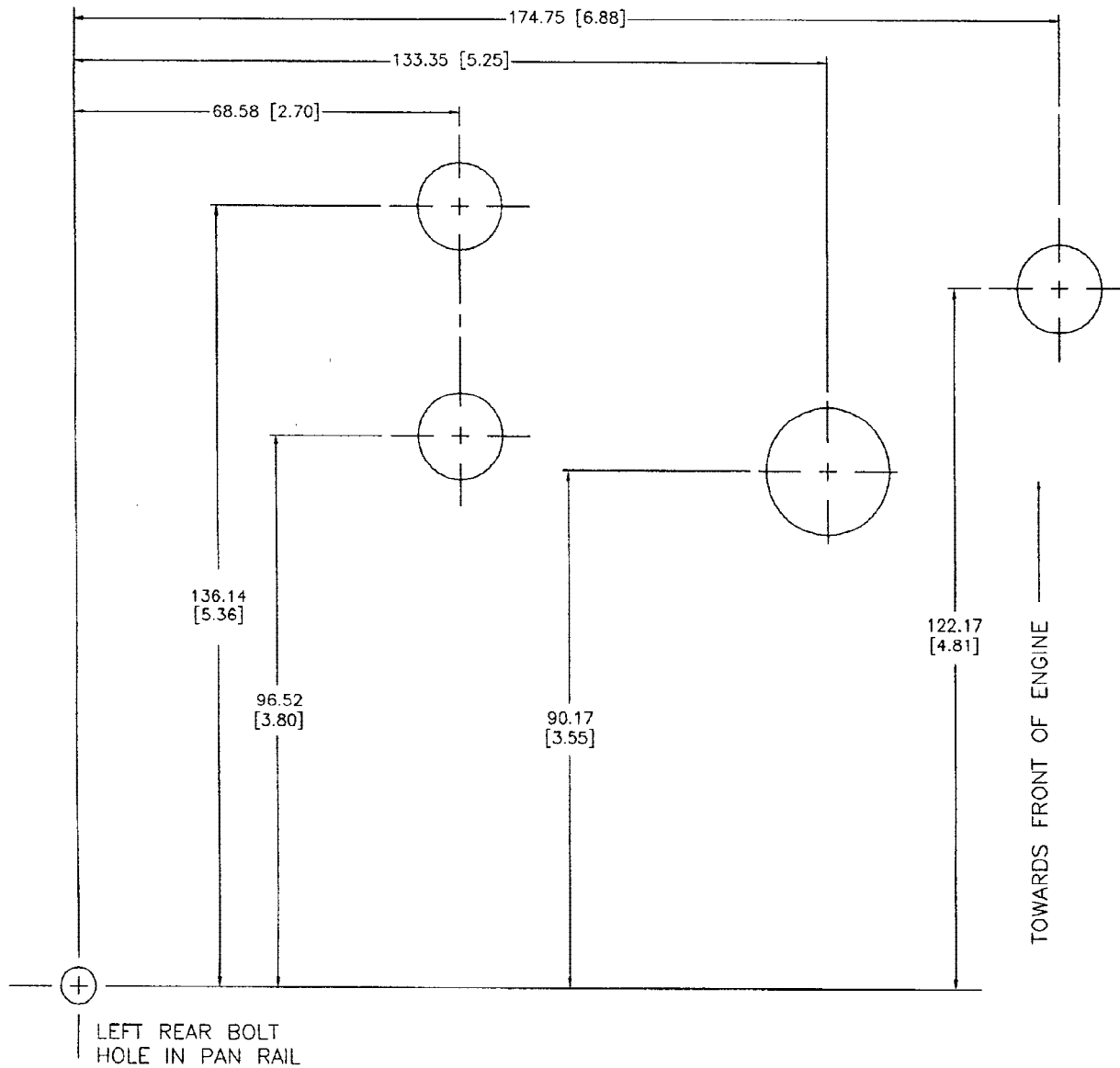

FIG. A2.11 Sequence VIB Pan Modifications



BAFFLE FLAT PATTERN LAYOUT

FIG. A2.12 Sequence VIB Oil Pan Baffle



MILLIMETERS [INCHES]

VIEW IS LOOKING DOWN INTO PAN PERPENDICULAR TO PAN RAILS. SCALE IS FULL SIZE

FIG. A2.13 Template for Oil Pan Connections

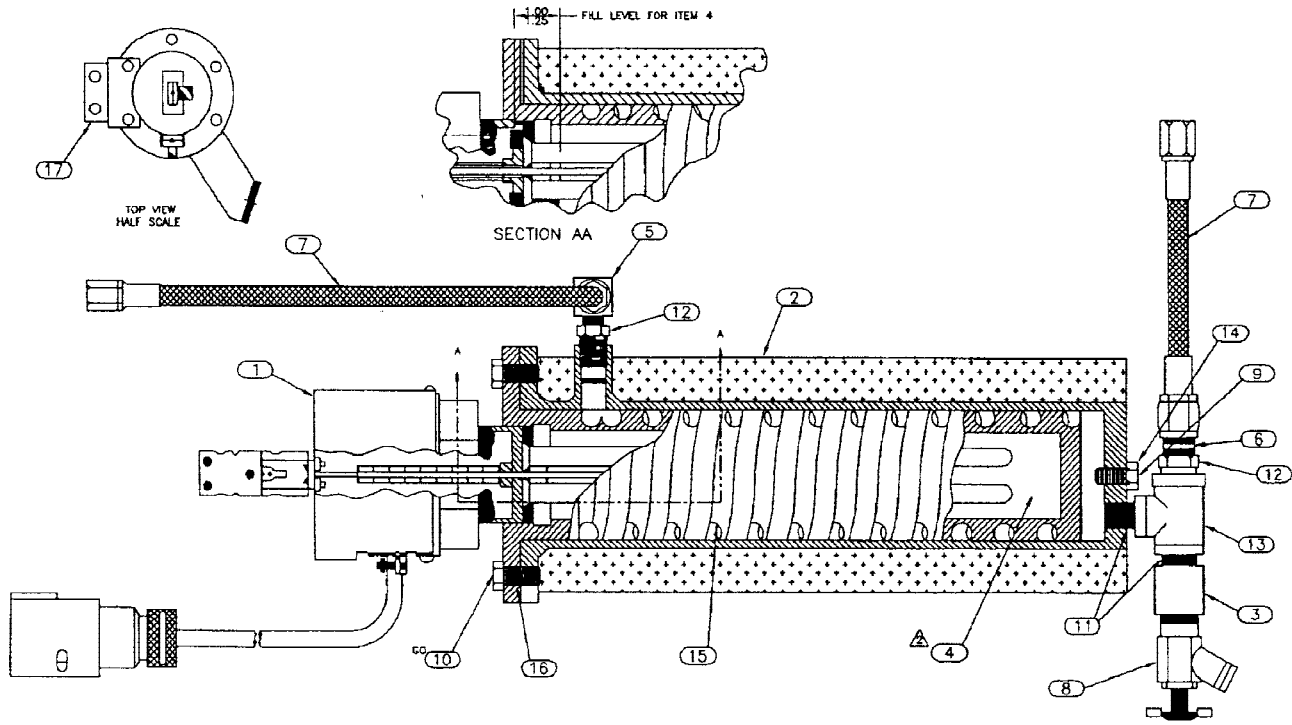

- 3. TWO ROWS X NOT ASSEMBLED
- ⚠️ FILL WITH APPROXIMATELY 12LB 11OZ OF CORRO-CAST (ITEM 4)
- 1. OIL CAPACITY 425-475 CC INCLUDING HOSE & FITTINGS AS SHOWN

FIG. A2.14 Thermocouple in Oil Heater

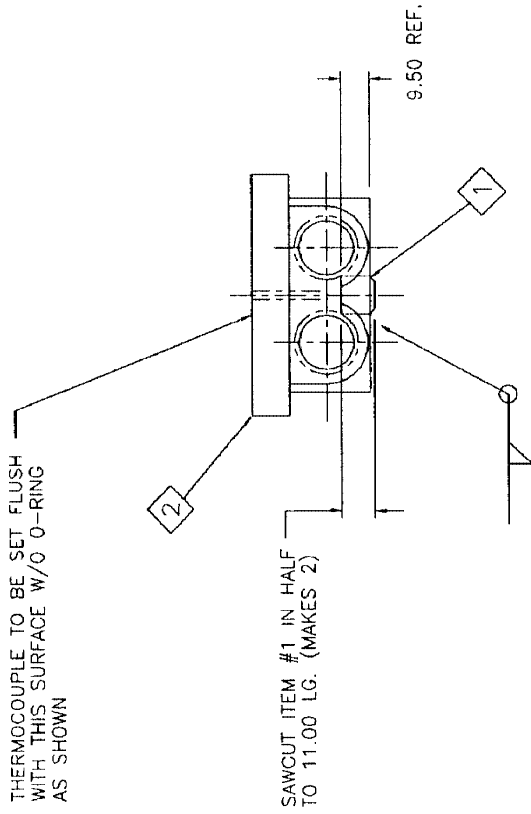

THERMOCOUPLE TO BE SET FLUSH WITH THIS SURFACE W/O O-RING AS SHOWN

SAWCUT ITEM #1 IN HALF TO 11.00 LG. (MAKES 2)

9.50 REF.

Ø8.75 THRU
LJØ16.00±0.50

IMPREGNATOR CERTIFICATION STAMP & LASER ETCH PART NO. THIS SURFACE

3	1	INSERT #OHT6A-007A-1
2	1	KIT #100292-01 HAYDEN (.62 O.D.x.94 LG.) #6061 ALUM. (.12-27 NPT) FULL PIPE COUPLING
1	1	DESCRIPTION
◇	REQ'D	BILL OF MATERIAL

ITEM #3 IS REQ'D FOR ASS'Y.
BRACKETED DIMENSIONS AREA IN INCHES

WELED CONSTRUCTION

USE CROWN #2319 WELDING ROD OR EQUIVALENT

NOTE: REPLACEMENT O-RING #2-230-N674-70 OBB SEAL

IMPREGNATE & PRESSURE TEST PER MIL-STD-276A

METRIC		STN.	REVISIONS	DATE
UNLESS OTHERWISE SPECIFIED, DIMENSIONS ARE IN MILLIMETERS				
TOLERANCES UNLESS SPECIFIED				
TITLE OIL FILTER ADAPTOR ASSY.				
MATERIAL SEE B/M				
SCALE FULL				
CHECKED BY D.H.				
DRAWN BY D.H.				
ASSEMBLY				
DATE 2-1-95				
OH TECHNOLOGIES INC.				
P.O. BOX 100				
CINC. OHT6A-007-1				

FIG. A2.15 Oil Filter Adaptor Assembly

Weld the coupling to the tubing. Place two marks on the tubing. First mark is 3.625 in. from coupling. This is the highest the float switch can be adjusted without making contact to the crankshaft. The second mark is 6.625 in. from the coupling. This is the lowest the float can be adjusted without making contact with the bottom of the pan. The dipstick hole in the block will have to be drilled and tapped for a 3/8" compression fitting (hole is about the right size already). Remove the farrels and replace with rubber O-rings. This allows the fitting to be loosened and the 3/8" tubing to be adjusted to the proper float switch setting. Each lab should double check the crank contact distance and oil pan bottom contact distance in their application as well as ensuring that the oil pan level their system requires can be met with this device. Overall length of the tubing is not critical, ours is 11.8125 in.

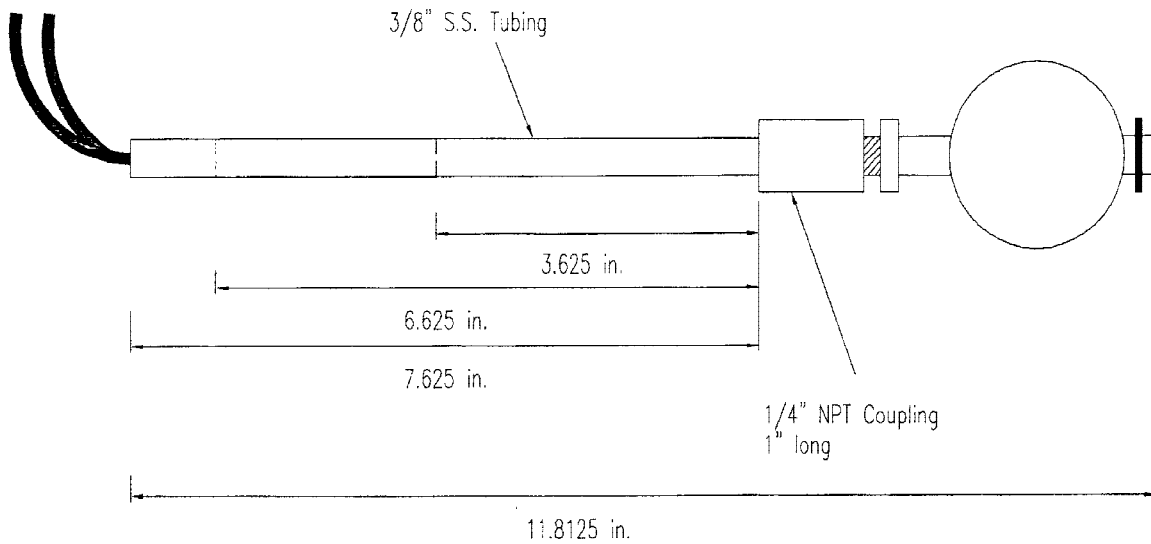
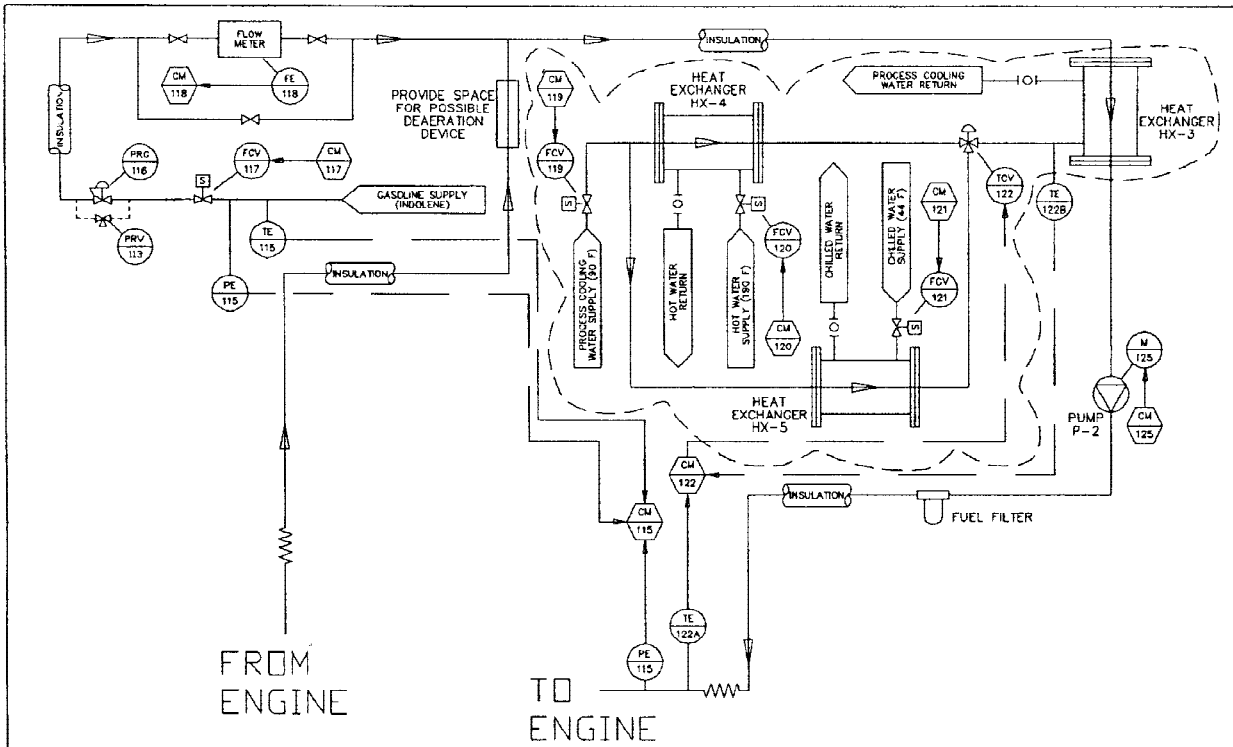

FIG. A2.16 Oil Pan Float Switch



SYMBOLS AND ABBREVIATIONS

C	COMMON	◇	MANUAL VALVE (SHUT-OFF)
CHW	CHILLED WATER (5F OR 40F BRINE TEMP)	◇	MANUAL VALVE (BALANCING)
COND	CONDENSATE	◇	CHECK VALVE
CP1	CONTROL PANEL FOR HVAC & DESICCANT DRYER UNITS (BY MANUF.)	◇	SOLENOID VALVE
CP2	CONTROL PANEL FOR TEMPERATURE AND HUMIDITY SETPOINTS	◇	CONTROL VALVE
CP3	CONTROL PANEL FOR CHILLER UNIT (BY MANUF.)	◇	SELF CONTAINED PRESSURE REGULATING VALVE
CTCV	CAPILLARY TEMPERATURE CONTROL VALVE	◇	SELF CONTAINED TEMPERATURE CONTROL VALVE WITH CAPILLARY TUBE
CW	CITY WATER	◇	3 WAY SOLENOID VALVE
FCS	FLOW CONTROL SOLENOID	◇	3 WAY CONTROL VALVE
FCV	FLOW CONTROL VALVE	◇	STRAINER
FE	FLOW ELEMENT	◇	FLOW OF INFORMATION
FI	FLOW INDICATOR (MANUAL)	◇	EQUIPMENT OR MEASURING DEVICE
FLS	FLOAT SWITCH	◇	CONTROL/COMPUTER FUNCTION
FS	FLOW SWITCH	◇	
HE	HUMIDITY ELEMENT	◇	
HX	HEAT EXCHANGER	◇	
LS	LEVEL SWITCH	◇	
M	MOTOR	◇	
NC	NORMALLY CLOSED	◇	
NO	NORMALLY OPEN	◇	
P	PUMP	◇	
PCD	PRESSURE CONTROL DAMPER	◇	
PCV	PRESSURE CONTROL VALVE	◇	
PE	PRESSURE ELEMENT	◇	
PI	PRESSURE INDICATOR (MANUAL)	◇	
PRG	PRESSURE REGULATING VALVE	◇	
PS	PRESSURE SWITCH	◇	
S	SOLENOID	◇	
STM	STEAM	◇	
TCV	TEMPERATURE CONTROL VALVE	◇	
TE	TEMPERATURE ELEMENT	◇	
TI	TEMPERATURE INDICATOR (MANUAL)	◇	
TS	TEMPERATURE SWITCH	◇	

Power-Tek Inc.		
SCALE ---	APPROVED	DRAWN B DEW
CHK'D M BUDI		DATE 01-11-95
TITLE		
DWG NO. M02C		

FIG. A2.17 Typical Fuel System

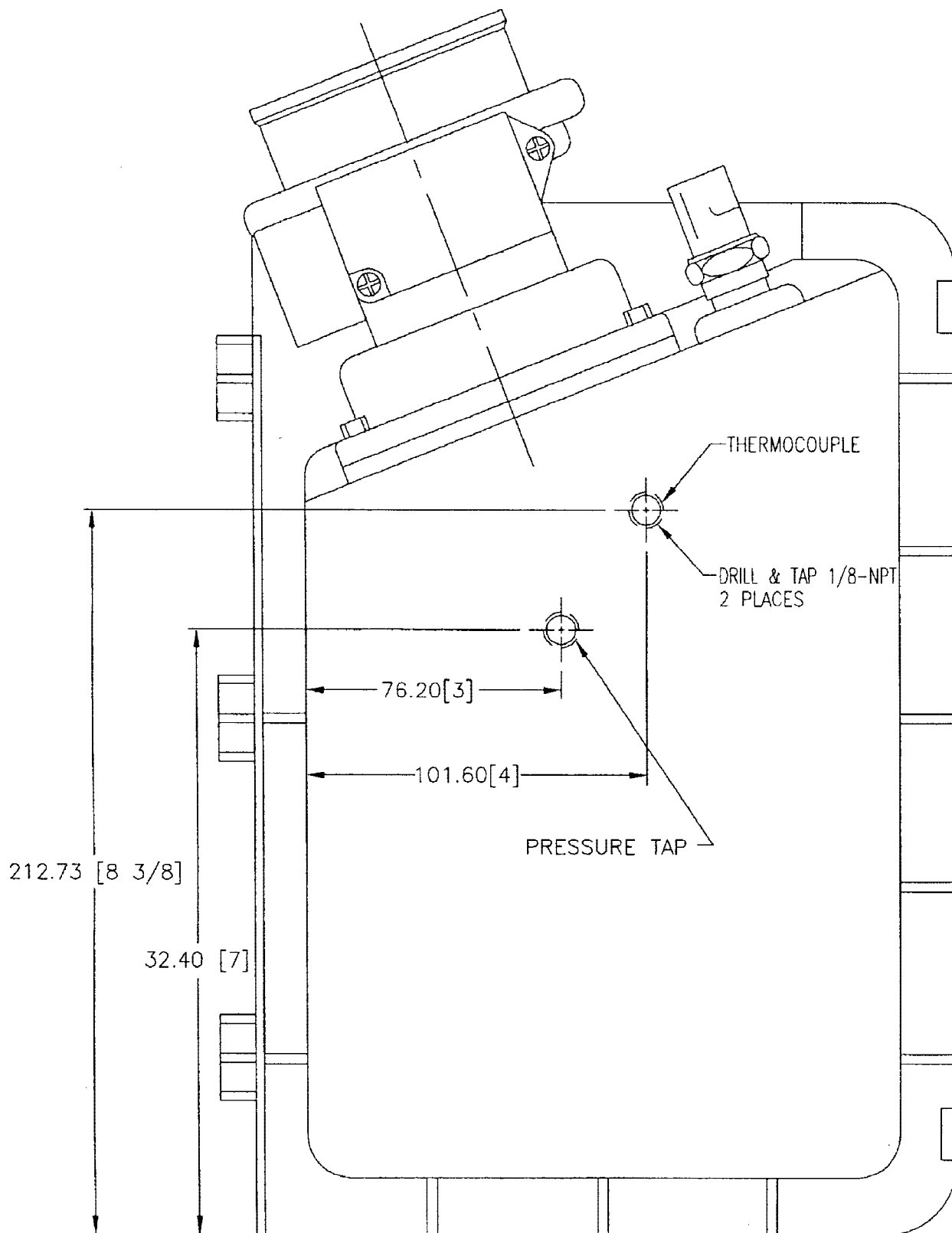

DIMENSIONS ARE IN MILLIMETERS AND [INCHES]

FIG. A2.18 Intake Air Cleaner Assembly

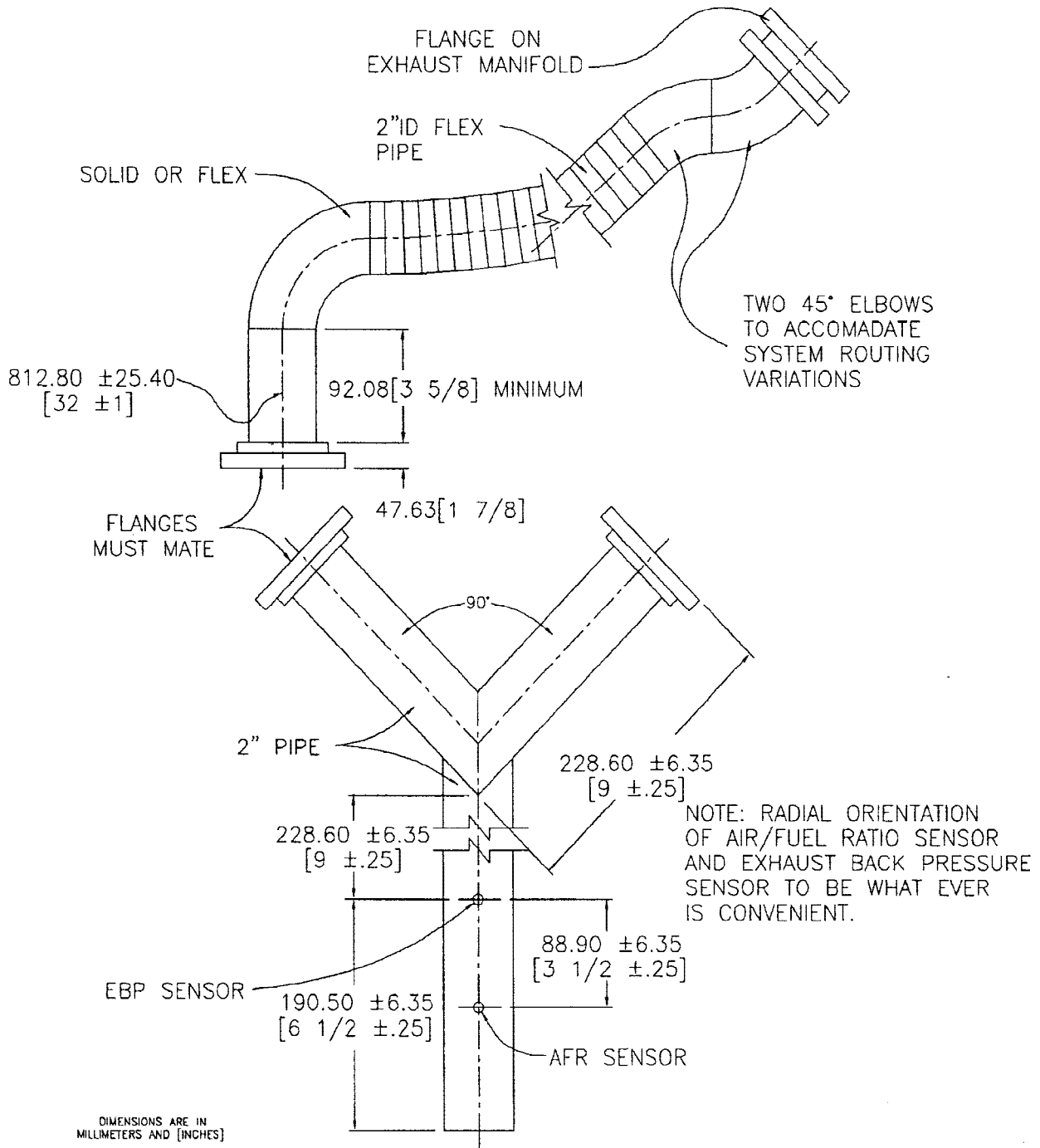
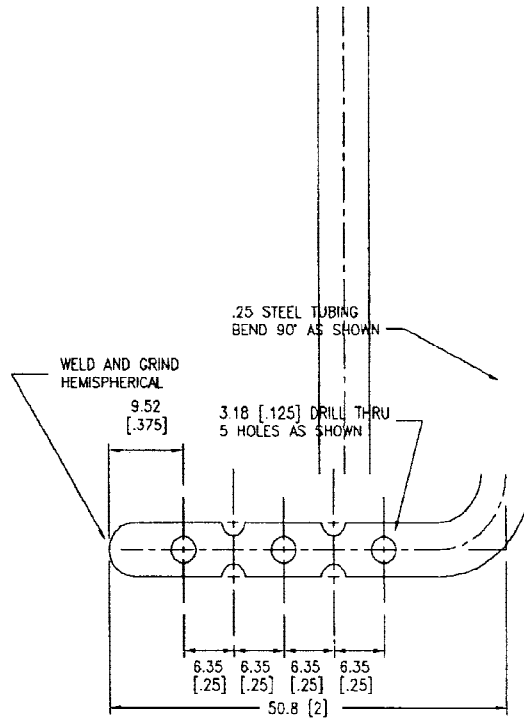
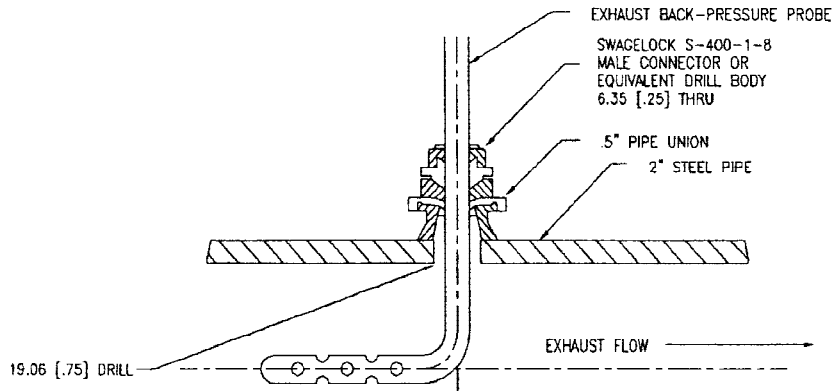

FIG. A2.19 Laboratory Exhaust System



PROBE DETAIL



NOTE: BEND EXTERNAL TUBING SEGMENT AFTER ASS'Y PARALLEL WITH PROBE AXIS AS SHOWN. THIS PERMITS VISUAL ALIGNMENT CHECK DURING OPERATION.

NOTE: PROBE ϕ TO BE COINCIDENT WITH PIPE ϕ

ASSEMBLY DETAIL

DIMENSIONS ARE IN MILLIMETERS AND [INCHES]

THBY SEPT84
C:DIESEL\EXBPR
REV 23JAN85

FIG. A2.20 Exhaust Back Pressure Probe

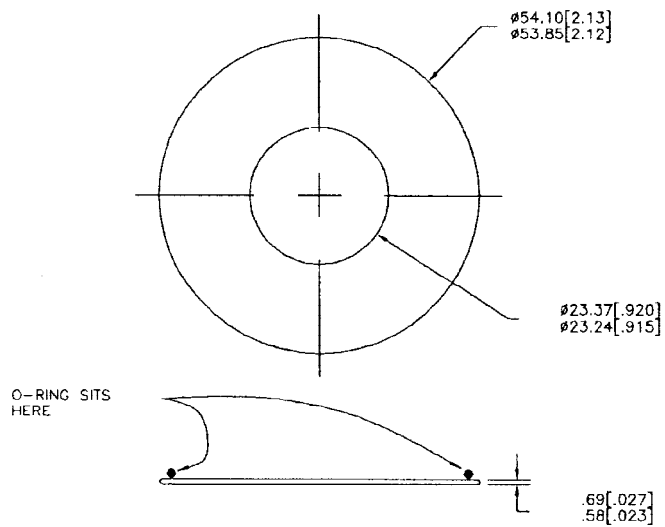

O-RING TO SEAL THERMOSTAT
IN HOUSING (INTAKE) IS FORD
PART N806807.

FIG. A2.21 Thermostat Orifice Plate

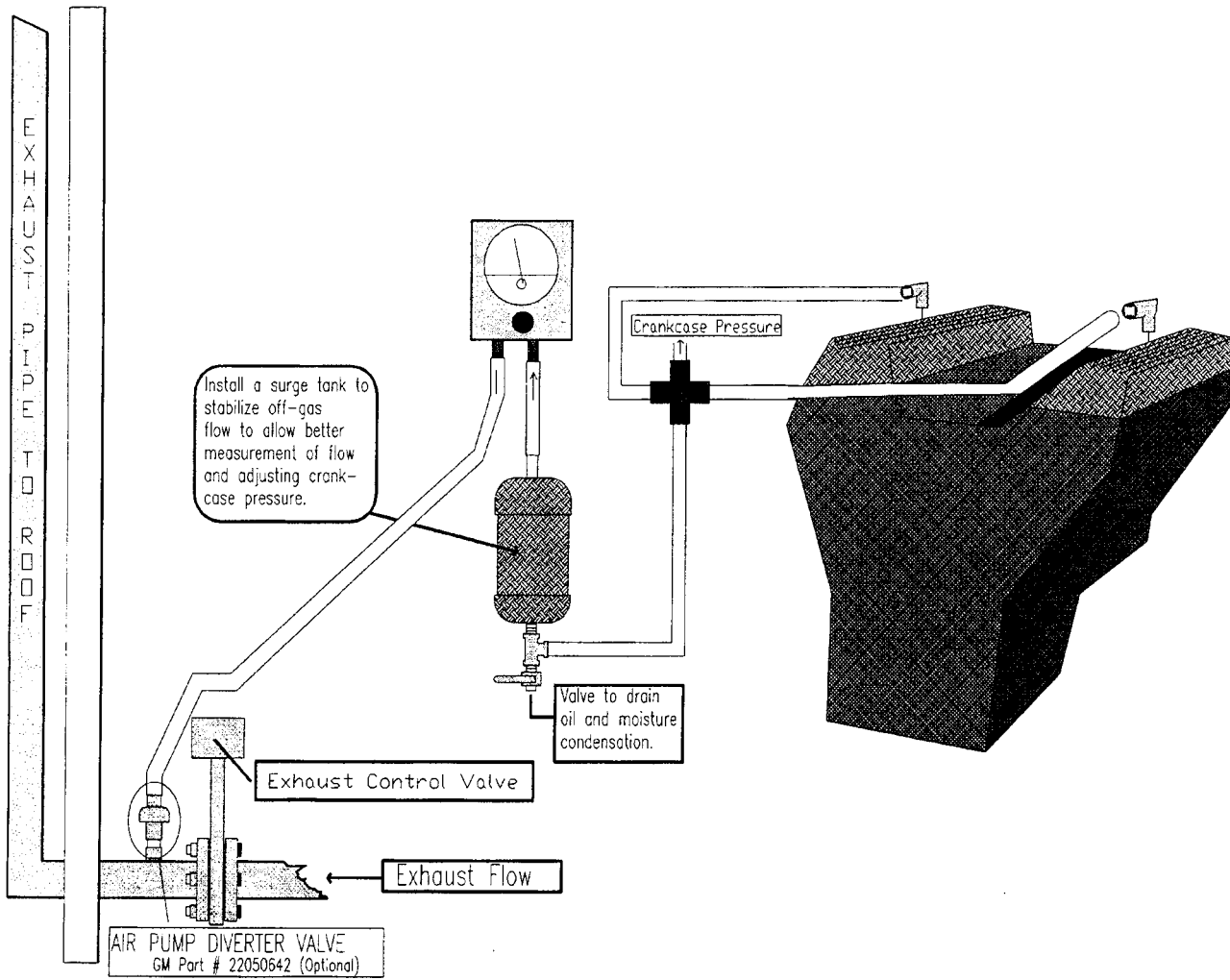

FIG. A2.22 Crankcase Pressure and Blow-by Ventilation System

Blowby Removal and Crankcase Pressure Control System

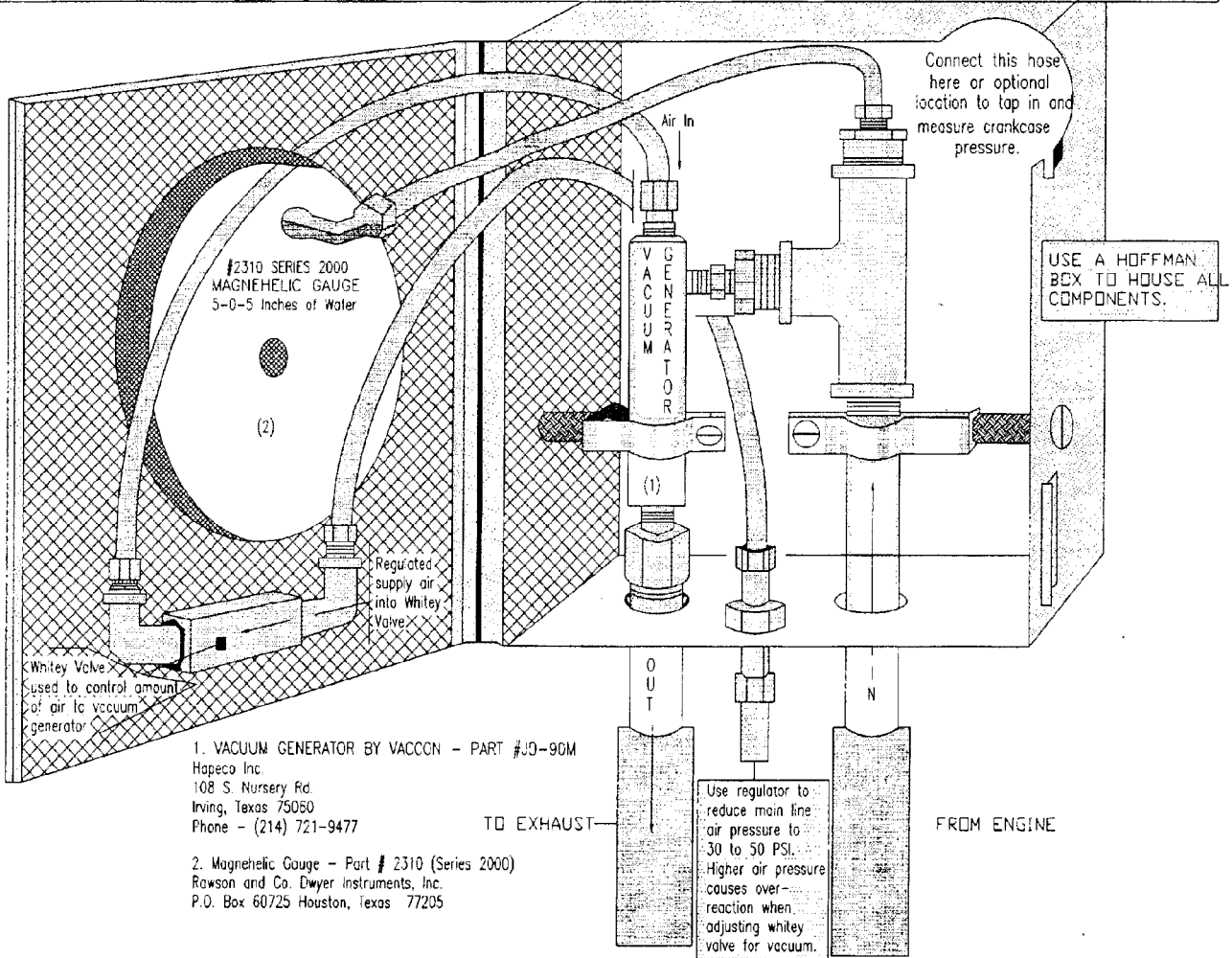

FIG. A2.23 Blow-by Removal System and Crankcase Pressure Control Setup

1. Original Engine Drain Plug
2. Standard Threaded Nut 3/4 - 16 (welded to drain plug)
3. 45° Positionable Male Elbow Part # SS-810-5-8ST
4. 3 inches of 1/2" SS Tubing
5. Male Elbow Part # SS-810-9
6. Insulated Aluminum 1/2" Strap Clamp (allows sliding adjustment of ruler on glass)
7. Steel Metric Ruler
(This is a level marker, the actual calibrated lines will be done at the time of the calibration)
8. Glass Tube 1/2" OD x 6 inches long
9. Rubber Cap 1/2" size (need to drill small hole for plastic fitting)
10. Plastic Vacuum Fitting (straight fitting pushed through cap)

Note:

1. Replace Steel Ferrules with Tycon Ferrules & Back-Part # T-810-Set
2. Connect rubber hose from plastic fitting to oil dipstick tube

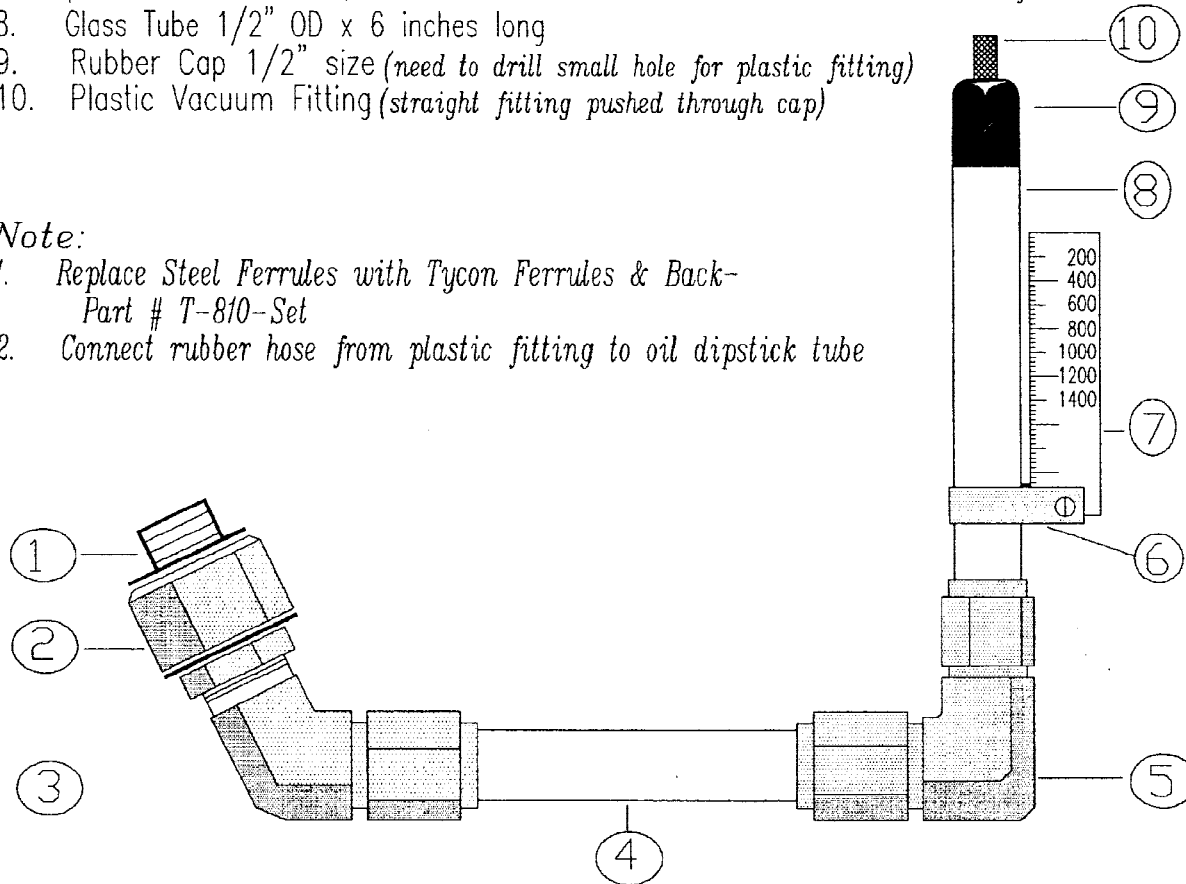

FIG. A2.24 Oil Level Measurement Setup

A3. OIL HEATER CERROBASE REFILL PROCEDURE

A3.1 The cylinder that holds the Cerrobases, Chromalox heater element, and thermocouple is called the cartridge. Take the cartridge out of its insulated case at the engine by backing out six 3/8-16 by 7/8 hex head screws. Hold the cartridge upright in a vise at the work bench.

A3.2 Remove the cable cover and cable connections at the heater element. It is a good idea to make a sketch of the cable connections and shorting bars because this arrangement is not always the same. Remove two 1/8 NPT pipe plugs at the top of the cartridge so the Cerrobases chamber will be fully vented to atmosphere.

A3.3 Using an acetylene torch, play it on all accessible surfaces of the cartridge until the Cerrobases is completely melted. The Cerrobases shall be liquid. Check with a preheated welding rod through one of the 1/8 NPT holes. Put a wrench on the 3-in. hex flat and try to remove the heater element from the cartridge. Again, be sure the Cerrobases is completely melted before screwing out on the 3 in. hex. Cerrobases melts at 255°F. Don't force the hex. Keep heating the cartridge and pumping the wrench until the heater element can be backed out of the cartridge.

A3.4 After removing the heater element, lay it aside and

pour the melted Cerrobased out of the cartridge into a suitable, dry receiver. Keep heat on the cartridge and be sure it is completely empty of Cerrobased and oxide. Clean all surfaces of the cartridge thoroughly by heating and wire brushing.

A3.5 Hold the heater element in a vise across the hex flats. Remove the thermocouple. Play the torch along the heater elements and wire brush, as necessary, to remove oxide.

A3.6 Replace the cartridge in the vise and heat it with a torch. If the Cerrobased is clean and bright, reuse it. In any case, melt 8.5 lb of Cerrobased, enough to fill the cartridge about two-thirds full. A good way to melt the Cerrobased is to hold the ladle in a vise. Heat the ladle and Cerrobased until melted, remembering to put occasional heat on the cartridge to keep Cerrobased in the cartridge liquid. Pour from the ladle carefully to avoid splashing. Avoid thermal shock by keeping all parts coming into contact with Cerrobased well heated.

A3.7 Preheat the heater element and immerse it in the liquid Cerrobased. Pull up on the 3 in. hex to secure the assembly. Screw the heater funnel into one of the 1/8 NPT holes. The heater funnel is made up of a heavy wall funnel welded to a 3 in. long, 1/8-in. pipe nipple.

NOTE A3.1—Do not over-torque the 3 in. hex because differential contraction can lock the hex.

A3.8 Keep playing the torch on the cartridge while working and when the heater funnel has been screwed in place, heat it also. Finish filling the cartridge with Cerrobased. Look through

the open 1/8 NPT hole to see the Cerrobased liquid level and pour Cerrobased through the funnel until the liquid level is within 2.250 and 2.375 in. of the top of the plug. As shown on TD-428, this will leave expansion space for the Cerrobased in the cartridge. If the cartridge should be overfilled use the following technique to remove Cerrobased.

A3.8.1 Cool a piece of welding rod in ice water. Wipe the rod completely dry and immerse it in the Cerrobased. Pull it out. Some Cerrobased will have solidified and frozen to the rod. Slide Cerrobased off the rod and repeat as necessary to get the liquid level to within 1/4 in. of the plug.

A3.9 Use a new thermocouple. Thread eleven heat insulation beads on the thermocouple. Check the Cerrobased with welding rod to be sure it is liquid. Preheat the thermocouple and push it into the Cerrobased through the center, 0.250-in. diameter drilled hole. The eleven beads will serve as a gage to determine immersion depth of the thermocouple. Ensure the 0.250-in. hole is clean. In the final assembly clearance between this hole and the thermocouple will be the only vent between the Cerrobased and atmosphere. Tie the thermocouple down, otherwise, the thermocouple will float out of the liquid Cerrobased.

A3.10 Let the cartridge cool to room temperature. Remove the heater funnel and install two 1/8 NPT pipe plugs. Connect the cable and shorting bars in their original arrangement. Replace the thermocouple connector and cable cover. Reinstall the cartridge in its insulated case at the engine.

A4. ENGINE PART NUMBER LISTING

A4.1 Table A4.1 lists the new parts required for each new engine and Table A4.2 lists other specified engine parts.

TABLE A4.1 New Parts Required for Each New Engine

Part Name	Part No.
Gasket, camshaft cover (R.H.)	F1AZ-6584-A
Gasket, camshaft cover (L.H.)	F1AZ-6584-B
Gasket, intake manifold to cylinder head (2 required)	F1AZ-9461-A
Gasket, oil filter adapter	F1AZ-6840-A
Gasket, oil pan	F1AZ-6710-A
Gasket, thermostat housing (O-ring)	F1VY-8255-A
Gasket, throttle body adapter	F1AZ-9H486-A
Gasket, throttle body	F1AZ-9E936-A
Gasket, EGR	GAZ-90476-B
Gasket, idle air control valve	E83T8F760
Gasket, water pump	F1VY-8507-A
Spark plugs	AWSF 32C or 32P

TABLE A4.2 Other Specified Engine Parts

Part Name	Part No.
Harmonic Balancer	F1AZ-6316-A ^A
Oil Pan	F1AZ-6675-A ^B
Intake Manifold	F1AZ-9424-C ^{B,C} or F1AE-9424 or F1AE-9425
Camshaft Cover (R.H.)	F1AZ-6582-A ^A
Camshaft Cover (L.H.)	F1AZ-6582-B ^A
Thermostat Housing	F1VY-8592-A ^B or F1AE-8594 ^{B,C}
Oil Filter Adapter	F1AZ-6881 ^{B,C} or F1AE-6881 ^{B,C} or F1AE-6884 ^{B,C}
Camshaft Positioner Sensor (CMP)	F1AZ-6B288-A ^A
Crankshaft Position Sensor (CKP)	F1AZ-6C315-A ^A
Water Temperature Indicator Sender	F1SZ-10884-A or F1SF-10884
Throttle Position Sensor (TP)	F2AZ-9B989-A or F2AF-9B989
Engine Coolant Temperature Sensor	F2AZ-12648-A or F2AF-12A648
Heated Exhaust Gas Oxygen Sensor	FOTZ-9F472 ^C
Air Charge Temperature (ACT) Sensor	F2DZ-12A697 ^C
Mass Air Flow Sensor	F2VF-12B579 ^C
Ignition Coil (R.H.)	F1VY-12029 ^A or F1VU-12029 ^A
Ignition Coil (L.H.)	F3VU-12029 ^A or F5LU-12029 ^A
Ignition Coil Bracket (R.H.)	F1AZ-12257 ^A
Ignition Coil Bracket (L.H.)	F3AZ-12257 ^A
Ignition Wires	F3PZ-12259-C
Ignition Control Module (ICM)	F1AZ-12K072-A or F1AF-12K072
Fuel Injectors	FOTZ-9F593 ^C
Fuel Rail	F2AZ-9F792-A ^C or F2AE-9F792 ^C
Fuel Pressure Regulator	E6AZ-9C968 ^C or E7DE-9C968 ^C
Air Cleaner Outlet Tube	F2AZ-9B659
Air Cleaner Outlet Tube Clamp	F2AZ-9A624-A
Crankcase Ventilation Tube	F1AZ-6C324-A
Engine Air Cleaner Assembly	F2AZ-9600
Air Cleaner Element	E5TZ-9601
Resonator Box	F2AE-9R504
Throttle Body	F2AZ-9E926 ^C or F2AE-9E926 ^C
Throttle Body Adapter	F2AE-9A589 ^C
Engine Wiring Harness	OHT6A-001-01
Engine Control Module	OHT6A-002-1, ECM/EEC
Special EPROM	Included in above
Exhaust Mainfold (R.H.)	F1AZ-9430-B
Exhaust Manifold (L.H.)	F1AZ-9431-B
Engine Flywheel	F6ZZ-6375-AB
Engine Mounts (R.H.)	DTSC-80-128-1
Engine Mounts (L.H.)	DTSC-80-126-1
Engine Mount Isolators	DTSC-40-132-1

^A Supplied with engine.

^B Required modification.

^C Shall be purchased from CPD.

A5. FLYING FLUSH CHECKLISTS

A5.1 Tables A5.1-A5.3 are examples of flying flush checklists; Table A5.1 is the detergent flush checklist; Table A5.2 is

the double flush to test oil checklist; and Table A5.3 is the double flush to BC oil checklist.

TABLE A5.1 Detergent Flush Checklist, BC After Test Oil

NOTE—Detergent flush with flush oil, then flush to BC.

Standard Checklist for Detergent Flush	
<input type="checkbox"/>	Set 1500/98/105/125 ^A until oil temperature is at 125°C (257°F)
<input type="checkbox"/>	Set 1500 r/min//98 N-m load
<input type="checkbox"/>	F/F ^B to BCFHD ^C , time
<input type="checkbox"/>	Set 1500/98/105/125 ^A
<input type="checkbox"/>	Run 30 min (until _____)
<input type="checkbox"/>	Set 1500 r/min//98 N-m load
<input type="checkbox"/>	F/F ^B to BCFHD ^C , time
<input type="checkbox"/>	Set 1500/98/105/125 ^A
<input type="checkbox"/>	Run 2 h (until _____)
<input type="checkbox"/>	Set 1500 r/min//98 N-m load
<input type="checkbox"/>	F/F ^B to BC Oil, time
<input type="checkbox"/>	Set 1500/98/105/125 ^A
<input type="checkbox"/>	Run 30 min (until _____ time)
<input type="checkbox"/>	Set 1500 r/min//98 N-m load
<input type="checkbox"/>	F/F ^B to BC Oil, time
<input type="checkbox"/>	Set 1500/98/105/125 ^A
<input type="checkbox"/>	Run 30 min (until _____ time)
<input type="checkbox"/>	Set 1500 r/min//98 N-m load ^A
<input type="checkbox"/>	F/F ^B to BC Oil, time
<input type="checkbox"/>	Continue with routine test operating checklist

^A This designation represents speed (r/min), load (N-m), coolant inlet temperature (°C), oil gallery temperature (°C) in all places where it appears in this checklist. English equivalent is (1500 r/min, 72.3 lbf-ft, 221°F, 257°F).

^B Designation for Flush/Fill procedure in which: (a) 6.0 L (6.34 qt) of oil are flushed in while; (b) 6.0 L (6.34 qt) of sump oil is scavenged out.

^C Designation for Flush Oil, ASTM BCFHD.

TABLE A5.2 Double Flush to Test Oil Checklist

Standard Checklist for Double Flush	
<input type="checkbox"/>	Set 1500/98/105/125 ^A until oil temperature is at 125°C (257°F)
<input type="checkbox"/>	Set 1500 r/min//98 N-m load
<input type="checkbox"/>	F/F ^B to _____ Oil, time
<input type="checkbox"/>	Set 1500/98/105/125 ^A
<input type="checkbox"/>	Run 30 min (until _____ time)
<input type="checkbox"/>	Set 1500 r/min//98 N-m load
<input type="checkbox"/>	F/F ^B to _____ Oil, time
<input type="checkbox"/>	Set 1500/98/105/125 ^A
<input type="checkbox"/>	Run 30 min (until _____ time)
<input type="checkbox"/>	Set 1500 rpm/98 N-m load ^A
<input type="checkbox"/>	F/F ^B to _____ Oil, time
<input type="checkbox"/>	Establish proper sump level with _____ oil
<input type="checkbox"/>	Continue with routine test operating checklist

^A This designation represents speed (r/min), load (N-m), coolant inlet temperature (°C), oil gallery temperature (°C) in all places where it appears in this checklist. English equivalent is (1500 r/min, 72.3 lbf-ft, 221°F, 257°F).

^B Designation for Flush/Fill procedure in which: (a) 6.0 L (6.34 qt) of oil are flushed in while; (b) 6.0 L (6.34 qt) of sump oil is scavenged out.

TABLE A5.3 Double Flush to BC Oil Checklist

NOTE—Double Flush to BC Oil Prior to Test Oil

Standard Checklist for Double Flush	
[]	Set 1500/98/105/125 ^A until oil temperature is at 125°C (257°F)
[]	Set 1500 r/min/98 N-m load
[]	F/F ^B to BC Oil time
[]	Set 1500/98/105/125 ^A
[]	Run 30 min (until ____ time)
[]	Set 1500 r/min/98 N-m load
[]	F/F ^B to BC Oil, time
[]	Set 1500/98/105/125 ^A
[]	Run 30 min (until ____ time)
[]	Set 1500 rpm/98 N-m load ^A
[]	F/F ^B to BC Oil, time
[]	Establish proper sump level with ____ oil
[]	Continue with routine test operating checklist

^A This designation represents speed (r/min), load (N-m), coolant inlet temperature (°C), oil gallery temperature (°C) in all places where it appears in this checklist. English equivalent is (1500 r/min, 72.3 lbf-ft, 221°F, 257°F).

^B Designation for Flush/Fill procedure in which: (a) 6.0 L (6.34 qt) of oil are flushed in while; (b) 6.0 L (6.34 qt) of sump oil is scavenged out.

A6. SAFETY PRECAUTIONS

A6.1 General Information

A6.1.1 The operating of engine tests can expose personnel and facilities to a number of safety hazards. It is recommended that only personnel who are thoroughly trained and experienced in engine testing should undertake the design, installation, and operation of engine test stands.

A6.1.2 Each laboratory conducting engine tests should have their test installation inspected and approved by their Safety Department. Personnel working on the engines should be provided with the proper tools, be alert to common sense safety practices, and avoid contact with moving or hot engine parts, or both. Guards should be installed around all external moving or hot parts. When engines are operating at high speeds, heavy duty guards are required and personnel should be cautioned against working alongside the engine and coupling shaft. Barrier protection should be provided for personnel. All fuel lines, oil lines, and electrical wiring should be properly routed, guarded, and kept in good order. Scraped knuckles, minor burns, and cuts are common if proper safety precautions are not taken. Safety masks or glasses should always be worn by personnel working on the engines and no loose or flowing clothing shall be worn near running engines.

A6.1.3 The external parts of the engine and the floor area around the engines should be kept clean and free of oil and fuel spills. In addition, the working areas should be free of all tripping hazards. In case of injury, no matter how slight, first aid attention should be applied at once and the incident reported. Personnel should be alert for leaking fuel or exhaust gas. Leaking fuel represents a fire hazard and exhaust gas fumes are noxious. Containers of oil or fuel cannot be permitted to accumulate in the testing area.

A6.1.4 The test installation should be equipped with a fuel shut-off valve which is designed to automatically cut off the fuel supply to the engine when the engine is not running. A remote station for cutting off fuel from the test stand is recommended. Suitable interlocks should be provided so that

the engine is automatically shut down when any of the following events occur: dynamometer loses field current, engine overspeeds, engine oil pressure is lost, exhaust system fails, room ventilation fails, or the fire protection system activates. Consider an excessive vibration pick-up interlock if equipment operates unattended. Fixed fire protection equipment should be provided.

A6.1.5 ASTM Sequence Tests use chemicals to clean engines between tests. Some of these chemicals require that personnel wear face masks, dust breathers, and gloves as exothermic reactions are possible. Emergency showers and face rinse facilities should be provided when handling such materials.

A6.2 Physical and Chemical Hazards List

A6.2.1 Physical Hazards:

A6.2.1.1 Hot engine parts, exhaust pipe

A6.2.1.2 Rotating engine/test stand parts (belts, pulleys, shafts)

A6.2.1.3 Electrical shock

A6.2.1.4 Noise

A6.2.2 Chemical and Materials Hazards:

A6.2.2.1 Gasoline—(Unleaded):

(1) Extremely flammable. Vapors harmful if inhaled. Vapors may cause flash fire.

(2) Keep away from heat, sparks, and open flames.

(3) Keep containers closed; use positive shut off valves on fuel lines.

(4) Use with adequate ventilation.

(5) Avoid buildup of vapors and eliminate all sources of ignition, especially non-explosion proof electrical apparatus and heaters.

(6) Avoid prolonged breathing of vapor.

(7) Avoid prolonged or repeated skin contact.

A6.2.2.2 Organic Solvent (Penmul L460):

(1) Before opening the container, relieve pressure. Keep the container tightly closed when not in use.

(2) Store at moderate temperatures and keep away from heat, sparks, open flame, and strong oxidizing agents.

(3) Use dry chemical, foam or CO₂ as extinguishing media.

(4) Use safety glasses and impervious gloves when handling.

(5) Use respiratory hydrocarbon vapor canister in enclosed areas.

(6) Use only if adequate ventilation is available.

(7) Avoid contact with eyes, skin, and clothing.

A6.2.2.3 *Aliphatic Naphtha (Stoddard Solvent):*

(1) Combustible vapor harmful if inhaled.

(2) Keep away from heat, sparks, open flame.

(3) Use with adequate ventilation.

(4) Avoid breathing vapor or spray mist.

(5) Use water spray, dry chemical, foam, or CO₂ as extinguishing media.

(6) Avoid prolonged or repeated contact with skin.

A6.2.2.4 *Cooling System Cleanser:*

(1) Store at moderate temperatures. Keep container closed until used.

(2) Use water spray, dry chemical, foam, or CO₂ as extinguishing media.

(3) Use safety glasses and impervious gloves when handling.

(4) Use respiratory protection in absence of proper environmental control.

(5) Use only if adequate ventilation is available.

(6) Avoid contact with eyes, skin, and clothing.

A6.2.2.5 *Oxalic Acid (Cooling System Cleanser):*

(1) Toxic substance. Avoid contact with eyes, skin, and clothing.

(2) Do not inhale dust.

(3) Keep away from feed or food products.

A6.2.2.6 *New and Used Oil Samples:*

(1) Store at moderate temperatures and keep away from extreme heat, sparks, open flame, and oxidizing agents.

(2) Use dry chemical, foam, or CO₂ as extinguishing media.

(3) Use safety glasses and impervious gloves when handling.

(4) Avoid contact with eyes, skin, and clothing.

A6.2.2.7 *Used Oil Samples Only*—Since used oils contain compounds that were not originally present in the new oil, stringently follow the Materials Safety Data Sheet’s guidelines for all components present.

NOTE A6.1—In addition to other precautions, note that continuous contact with used automotive engine oils has caused skin cancer in laboratory mice.

A7. SEQUENCE VIB TEST REPORT FORMS AND DATA DICTIONARY

NOTE A7.1—The actual report forms and data dictionary must be downloaded separately from the ASTM TMC Web Page at <http://astmtmc.cmu.edu/> or can be obtained in hardcopy format from the TMC.

FORM 1	Test Report Cover
FORM 2	Table of Contents
FORM 3	Summary of Test Method
FORM 4	Test Result Summary—Non-reference and Reference Oil
FORM 5	Operational Data Analysis
FORM 6	Operational Data Analysis
FORM 7	General Parameter Listing—16 Hour Aging
FORM 8	General Parameter Listing—80 Hour Aging
FORM 9	General Parameter Summary—BC Before Test Oil
FORM 10	General Parameter Summary—Test Oil Phase I
FORM 11	General Parameter Summary—Test Oil Phase II

FORM 12	General Parameter Summary—BC After Test Oil
FORM 13	Critical Parameter Summary—Stage 1
FORM 13A	Critical Parameter Summary—Stage 1
FORM 14	Critical Parameter Summary—Stage 2
FORM 14A	Critical Parameter Summary—Stage 2
FORM 15	Critical Parameter Summary—Stage 3
FORM 15A	Critical Parameter Summary—Stage 3
FORM 16	Critical Parameter Summary—Stage 4
FORM 16A	Critical Parameter Summary—Stage 4
FORM 17	Critical Parameter Summary—Stage 5
FORM 17A	Critical Parameter Summary—Stage 5
FORM 18	Supplemental Operational and Maintenance Record
FORM 19	Used Oil Analysis

A8. STATISTICAL EQUATIONS FOR MEAN AND STANDARD DEVIATION

A8.1 Equations

$$\text{mean} = \frac{1}{n} \sum_{i=1}^n [Y_i(\text{standard}) - Z_i(\text{reading})] \quad (\text{A8.1})$$

$$\text{standard deviation} = \sqrt{\frac{\sum_{i=1}^n [(Y_i - Z_i) - \text{mean}]^2}{df}} \quad (\text{A8.2})$$

where:

n = total number of data pairs, and

df = degrees of freedom = $n - 1$.

A9. OIL SUMP FULL LEVEL/OIL SIGHT GLASS CALIBRATION PROCEDURE

A9.1 Determining the Oil Sump Full Level

A9.1.1 Verify engine orientation on the test stand:

A9.1.1.1 Side to side engine mounting ($0.0 \pm 0.5^\circ$),

A9.1.1.2 Engine flywheel friction faceplate ($3.6 \pm 0.5^\circ$),
and

A9.1.1.3 U-joint angle no greater than 2.0° in the vertical
and 0.0° in the horizontal.

A9.1.2 Charge the engine with 6.0 L (6.34 qt) of BC oil.

A9.1.3 Start the engine and bring to stage 5 conditions.
Stabilize for 15 min.

A9.1.4 Shut engine down.

A9.1.5 Remove the oil from the engine using the scavenge
pump.

A9.1.6 Disconnect all lines from the oil pan and allow to
gravity drain.

A9.1.7 Connect the complete external oil system, including
the engine oil filter, in series and in the same direction as
normal oil flow. Use extra lines if needed to connect the engine
oil filter into the complete system.

A9.1.8 Set the 3-way control valve (TCV-144) so that
100 % of the flow is through the heat exchanger (HX-60).

A9.1.9 Connect and purge air through the external oil flush
system (step 7) using a minimum of 20 psi. (**Warning**—
Recirculating oil pump shaft shall be locked to avoid damage)

A9.1.10 Flow air through the external oil flush system (step
7) until most of the oil has been purged from the system.

A9.1.11 Cycle the 3-way control valve (TCV-144) a few
times to ensure oil is purged from the bypass section of the heat
exchanger (HX-6).

A9.1.12 Disconnect air supply.

A9.1.13 Connect stoddard solvent flush system to the exter-
nal oil flush system (step 7).

A9.1.14 Circulate stoddard solvent (minimum of 8 L)
through the external oil flush system (step 7) for a minimum of
30 min.

A9.1.15 Cycle the 3-way control valve (TCV-144) a few
times to ensure oil is purged from the bypass section of the heat
exchanger (HX-6).

A9.1.16 Disconnect the stoddard solvent flush system and
drain the solvent from the external oil flush system.

A9.1.17 Connect and purge air through the external oil flush
system (step 7) for minimum of 1 h using a minimum of 20 psi.
The 3-way control valve (TCV-144) shall be set so that 100 %

of the flow is through the heat exchanger (HX-6) for most of
the hour. Cycle the 3-way control valve (TCV-144) a few times
during the hour to ensure the stoddard solvent has been flushed
from the bypass section of the heat exchanger (HX-6).

A9.1.18 Individually check, and purge with air if necessary,
the heat exchanger (HX-6), oil heater, circulating oil pump, and
oil filters to ensure all the stoddard solvent has been removed.

A9.1.19 Measure 6.0 L (6.34 qt) of BC oil and pour into
engine.

A9.1.20 Start engine and ramp to Phase I Aging test
conditions.

A9.1.21 Once stabilized at the above conditions, mark the
level on the sight glass (A2.24) and consider this as the Oil
Sump Full Level.

A9.2 Oil Pan Sight Glass Calibration

A9.2.1 With the proper full mark established on the oil pan
sight glass tube and the engine running at Phase I aging
conditions drain 200 mL of oil from the engine at the outlet
(top) of the oil heater. Allow a few minutes for the system to
stabilize, then mark the sight glass (-200 mL).

A9.2.2 Repeat above in increments of 200 mL until a total
of 2000 mL has been removed from engine. Mark the sight
glass in increments of 200 mL. Any additional marks below the
2000 mL are optional.

A9.2.3 Return the 2000 mL of oil with engine running at
Phase I aging conditions, allow the system to stabilize a few
minutes. The oil level should now be at the original full mark
on the sight glass. Repeat the calibration procedure if the level
does not return to the original sight glass full mark.

A9.2.4 Determine the oil level in the oil pan using a level
made of Tygon tubing filled with water. Use the full mark on
the oil sight glass as the reference point.

A9.2.5 Mark the oil level on the outside of the oil pan with
a paint marker.

A9.2.6 The paint mark on the oil pan shall be approximately
located 38 mm to the rear of the second oil pan bolt (second
from the rear of the oil pan) and lined up with the front edge
of the oil pan gasket locating tab.

A9.2.7 Measure the distance from the bottom surface of the
oil pan rail (not the re-enforcement bar but the actual rail itself)
to the paint mark. This is the engine oil full level measurement.
This measurement shall be 43 ± 5 mm.

A10. FUEL INJECTOR EVALUATION

A10.1 *Fuel Injector Test Rig*—A suitable device capable of
accurate, repeatable flow measurement of port fuel injectors is
required. This device shall be capable of performing necessary
port fuel injector evaluations as outlined in A10.2. Since no
suitable commercially available apparatus has been identified,
design of the test rig is up to the laboratory. Flow test the
injectors using Stoddard Solvent as the test fluid.

A10.2 *Fuel Injectors*—Prior to engine installation, evaluate
all injectors (new and used) for spray pattern and flow-rate
using the test rig in A10.1. Injectors may be cleaned and reused
if the criteria outlined in this procedure are satisfied.

A10.2.1 Perform a visual inspection of each injector to
ensure that each injector has been cleaned of all oily deposits.

A10.2.2 Check the injector “O” ring for cracking or tearing and replace as required.

A10.2.3 Flush new injectors for 30 s to remove any assembly residue before flow testing.

A10.2.4 Place the injector(s) in the test rig and turn the test fluid on. Verify the flow of test fluid through the injector(s). Maintain the test fluid pressure supplied to the injector(s) at 290 ± 3.4 kPa during the entire test. The maintenance of this pressure is critical as a small change in pressure will have a dramatic effect on the flow rate and spray pattern. Once pressure is set, zero the volume measuring device.

A10.2.5 Flow-test each injector for a 60-s period. While the injector is flowing, make a visual observation of the spray pattern quality. The spray pattern shall be typical for the make and model of the injector.

A10.2.6 The set of injectors for an engine shall have a flow rate within 5 mL of each other. Discard any injector that does not flow within this range.

A10.2.7 At completion of the 60-s period close the injector and maintain the test fluid pressure for a minimum of 30 s. Discard any injector that leaks or drips.

A11. PRE-TEST MAINTENANCE CHECKLIST

TABLE A11.1 Pre-test Maintenance Checklist

Required Maintenance	Prior to Each Test Start	Prior to Each Reference Start ^A	As Noted
Replace spark plugs		X	
Service racor filters	X		
Verify injector flows		X	
Clean/recondition throttle body			<i>B</i>
Clean coolant heat exchanger			<i>C</i>
Clean / flush oil heat exchanger			<i>B</i>
Replace fuel filters		X	
Inspect / service driveline		X	
Rotate dyno trunion bearings			<i>D</i>
Clean / replace EBP probe			<i>D</i>

^A Only required on initial reference in a series.

^B With installation of new engine.

^C As required by normal laboratory practice.

^D Every six months.

A12. BLOW-BY VENTILATION SYSTEM REQUIREMENTS

A12.1 NPT cross fitting, $\frac{3}{8}$ -in.

supplied with the engine.

A12.2 NPT pipe nipple (three), $\frac{3}{8}$ -in., used to connect the $\frac{5}{8}$ -in.(I.D.) hose to the $\frac{3}{8}$ -in NPT cross fitting.

A12.5 Right rocker cover shall have 20 ± 2 in. of $\frac{5}{8}$ (I.D.)-in. hose to the $\frac{3}{8}$ -in. NPT cross fitting.

A12.3 Stainless steel elbow, $\frac{1}{2}$ -in., installed in the right side of the rocker cover.

A12.6 Left rocker cover shall have 20 ± 2 in. of $\frac{5}{8}$ (I.D.)-in. hose to the required cross fitting.

A12.4 Left rocker cover shall use the original elbow fitting

A12.7 Monitor crankcase pressure at the top of the $\frac{3}{8}$ -in. NPT cross fitting.

A13. VIBSJ ABBREVIATED LENGTH TEST REQUIREMENTS

A13.1 Calibration Test Acceptance (see 10.1)

A13.1.1 Calibration status of the VIBSJ is determined by successfully calibrating a test stand according to the Sequence VIB requirements detailed in 10.1. In other words, a stand that is calibrated for the Sequence VIB testing is automatically calibrated for VIBSJ testing.

A13.2 Procedure

A13.2.1 Operate the test according to test conditions in Table 3.

A13.2.2 Conduct the test as outlined in 11.5-11.5.5.6.

A13.2.3 The VIBSJ test is complete at the end of Test Oil Phase I, Stage 5 data acquisition (see 11.5.5.6).

A13.2.4 A VIBSJ test counts as one of the non-reference oil test starts allowed during a Sequence VIB calibration period.

A13.3 Calculation of Test Results (Refer to Table 6 for the Nominal Power and Time Weighting Factors)

A13.3.1 For Stage 1, steps 1 through 6 round and record the 5-min BSFC measurements to 4 decimal places using ASTM rounding.

A13.3.2 Average the BSFC measurements of the six steps to 5 decimal places using ASTM rounding. Units for BSFC are kg/kW-h.

A13.3.3 Multiply the average by the shown nominal power and time factor for Stage 1 (see Table 6) and record the answer to 6 decimal places. The unit for this number is kg of fuel consumed.

A13.3.4 Perform calculation steps A13.3.1-A13.3.3 for the remaining test Stages (2 to 5) using the respective nominal power and time factors (see Table 6).

A13.3.5 Total the mass fuel consumption values for all 5 stages.

A13.3.6 Complete the total fuel consumed calculation detailed in steps 1 to 5 above for the BC Before Test Oil and Test Oil.

A13.3.7 Compute the test oil fuel economy improvement (FEI) as follows:

$$\% \text{ FEI} = [(\text{BC Before} - \text{Test Oil}) \div (\text{BC Before})] \times 100$$

A13.3.8 Adjust the FEI result(s) on non-reference oil tests for the stand/engine severity in accordance with Annex A7.

APPENDIX

(Nonmandatory Information)

XI. PROCUREMENT OF TEST MATERIALS

INTRODUCTION

Throughout the text, references are made to necessary hardware, reagents, materials, and apparatus. In many cases, for the sake of uniformity and ease of acquisition, certain suppliers are named. If substitutions are deemed appropriate for the specified suppliers, permission in writing must be obtained from the TMC before such will be considered to be equivalent. The following entries for this appendix represent a consolidated listing of the ordering information necessary to complete the references found in the text.

X1.1 General Communications Concerning Sequence VIB Reference Tests, Procedural Questions and Non-Reference Tests:

ASTM Test Monitoring Center
Attention: Administrator
6555 Penn Avenue
Pittsburgh, PA 15206-4489
Telephone: (412) 365-1005

X1.2 Reference Oils and Calibration Oils:
Purchase reference oils and calibration oils by contacting:

ASTM Test Monitoring Center
Attention: Operations Manager
6555 Penn Avenue
Pittsburgh, PA 15206-4489
Telephone: (412) 365-1010

X1.3 Test Engines:
Sequence VIB engines, part No. R2G-800-XB (AOD-E)
AER

1605 Surveyor Blvd.
P.O. Box 979
Carrollton, TX 75011-0979
Telephone: (972) 417-3182
Fax: (972) 417-3165

X1.4 Dynamometer:
A Midwest Model 758 (50-hp) dry gap dynamometer may be ordered from:

Midwest Dynamometer Engineering Company
3100 River Road
River Grove, IL 60171
Telephone: (708) 453-5156
Fax: (708) 453-5171

X1.5 Dynamometer Load Cell:

The recommended load cell is a Lebow Model 3397 which may be ordered from:

Eaton Corporation
Lebow Products
1728 Maplelawn Road
P.O. Box 1089
Troy, MI 48099
Telephone: (313) 643-0220
Fax: (313) 643-0259

X1.6 Cooling System Pressure Cap:
A satisfactory coolant system pressure cap (69 kPa, normally closed cap) is available through local distributors.

X1.7 Cooling System Pump (P-1):
The specified cooling system pump may be obtained from:

Gould Pumps, Inc.
240 Fall Street
Seneca Falls, NY 13148

X1.8 Coolant Heat Exchanger (HX-1):

ITT (Model 320-20)
ITT Standard
175 Standard Parkway
Buffalo, NY 14227

or

Bell & Gossett (BP 75H-20 or BP 420-20)
Bell & Gossett ITT
8200 N. Austin Avenue
Morton Grove, IL 60053

X1.9 Coolant Orifice Plate (Differential Pressure):
Daniel Flow Products, Inc.
Flow Measurement Products Division
P.O. Box 19097

Houston, TX 77224
Telephone: (713) 467-6000
Fax: (713) 827-3880

X1.10 Coolant Control Valves (TCV-104, FCV-103 and TCV-101):

Badger Meter, Inc.
P.O. Box 581390
Tulsa, OK 74158
Telephone: (918) 836-8411

X1.11 Differential Pressure Transducer (DPT-1):
The recommended transducers are Viatran Model 274 or Model 374, Validyne Model DP15, and Rosemount model 1151 which may be ordered from:

Viatran Corp.
300 Industrial Drive
Grand Island, NY 14072
Telephone:(716) 773-1700
or
Validyne Engineering Corp.
8626 Wilbur Ave.
Northridge, CA 91324
Telephone:(818) 886-2057
or
Rosemount Inc.
4001 Greenbriar Street 150B
Stafford, Texas 77477
Telephone:1-800 999-9307

X1.12 Water Pump Plate:
The water pump may be modified by the laboratory, a water pump plate may be fabricated by the laboratory or a water pump plate may be purchased from:

OHT Technologies, Inc.
9300 Progress Parkway
P.O. Box 5039
Mentor, OH 44061-5039
Telephone: (440) 354-7007
Fax (440) 354-7080

X1.13 Oil Scavenge Pump (P-3):
Houdaille Industries, Inc.
Viking Pump Division
George and Wyeth Street
Cedar Falls, IA 50613
Telephone: (319) 266-1741

X1.14 Float Switch (FLS-136 and FLS-152):
Imo Industries Inc.
Gems Sensor Division
1 Cowles Road
Plainville, CT 06062-1198
Telephone: (203) 747-3000
Fax: (203) 747-4244

X1.15 Oil Circulation Pump (P-4):
Houdaille Industries, Inc.
Viking Pump Division
George and Wyeth Street

Cedar Falls, IA 50613
Telephone: (319) 266-1741

X1.16 External Oil System Solenoid Valves (FCV-150A, FCV-150C, FCV-150D, FCV-150E and FCV-150F):

Burkert Contromatic Corp.
1091 N. Batavia Street
Orange, CA 92667
Telephone: (714) 744-3230
Fax: (714) 639-4998

X1.17 External Oil System Control Valves (TCV-144 and TCV-145):

Badger Meter, Inc.
P.O. Box 581390
Tulsa, OK 74158
Telephone: (918) 836-8411

X1.18 Oil Heat Exchanger (HX-6):

ITT (Model 310-20):
ITT Standard
175 Standard Parkway
Buffalo, NY 14227
or
Bell & Gossett (Model BP 25-20 or BP 410-020):
Bell & Gossett ITT
8200 N. Austin Avenue
Morton Grove, IL 60053

X1.19 Electric Oil Heater Housing (EH-5):

TEI
12718 Cimarron Path
San Antonio, TX 78249
Telephone: (210) 690-1958
Fax: (210) 690-1959

X1.20 Oil Filter Housing Assembly and Filters (Screen) (FIL-2):

Racor:
PO Box 3108
Modesto, CA 95353
Telephone: (800) 344-3286
or
OH Technologies Inc.
9300 Progress Parkway
P.O. Box 5039
Mentor, OH 44061-5039
Telephone: (440) 354-7007
Fax: (440) 354-7080

X1.21 Modified Oil Filter Adapter Assembly:

OH Technologies, Inc.
9300 Progress Parkway
P.O. Box 5039
Mentor, OH 44061-5039
Telephone: (440) 354-7007
Fax: (440) 354-7080

X1.22 External Oil System Hose and Quick Disconnect Fittings:

Aeroquip products are available through local distributors or:
Aeroquip Corporation
Industrial Division
1225 W. Main Street
Van Wert, OH 45891
Telephone: (419) 238-1190

X1.23 Modified Oil Pan and Modified Oil Pick-Up Tube:
The oil pan and the oil pick-up tube may be modified by the laboratory or may be purchased from:
OH Technologies, Inc.
9300 Progress Parkway
P.O. Box 5039
Mentor, OH 44061-5039
Telephone: (440) 354-7007
Fax: (440) 354-7080

X1.24 Fuel Flow Measurement Mass Flow Meter:
MicroMotion, Inc.
7070 Winchester Circle
Boulder, CO 80301
Telephone: (303) 530-8400 or (800) 522-6277
Fax: (303) 530-8209

X1.25 AFR Analyzer:
The recommended AFR analyzer is a Horiba MEXA 110 which may be ordered from:
Horiba Instruments, Inc.
17671 Armstrong
Irvine Industrial Complex
Irvine, CA 92623
Telephone: (714) 250-4811

X1.26 ECM/EEC (Engine Control Module):
OH Technologies Inc.
9300 Progress Parkway
P.O. Box 5039
Mentor, OH 44061-5039
Telephone: (440) 354-7007
Fax: (440) 354-7080

X1.27 Thermostat Orifice Plate:
The thermostat orifice plate may be fabricated by the laboratory or may be purchased from:
OH Technologies Inc.
9300 Progress Parkway
P.O. Box 5039
Mentor, OH 44061-5039
Telephone: (440) 354-7007
Fax: (440) 354-7080

X1.28 Engine Wiring Harness Without Interface:
OH Technologies Inc.
9300 Progress Parkway
P.O. Box 5039
Mentor, OH 44061-5039
Telephone: (440) 354-7007
Fax: (440) 354-7080

X1.29 Modified Coolant Outlet (Thermostat Housing):

The thermostat housing may be modified by the laboratory or may be purchased from:
OH Technologies Inc.
9300 Progress Parkway
P.O. Box 5039
Mentor, OH 44061-5039
Telephone: (440) 354-7007
Fax: (440) 354-7080

X1.30 Modified Coolant Inlet (Oil Filter Adapter):
The coolant inlet adapter may be modified by the laboratory or may be purchased from:
OH Technologies Inc.
9300 Progress Parkway
P.O. Box 5039
Mentor, OH 44061-5039
Telephone: (440) 354-7007
Fax: (440) 354-7080

X1.31 Fuel Rail Adapter Set:
The fuel rail may be modified by the laboratory or a fuel rail adapter set may be purchased from:
OH Technologies Inc.
9300 Progress Parkway
P.O. Box 5039
Mentor, OH 44061-5039
Telephone: (440) 354-7007
Fax: (440) 354-7080

X1.32 Organic Solvent (Penmul L460):
Penetone Corporation
74 Hudson Avenue
Tenafly, NJ 07670

X1.33 Aliphatic Naphtha:
Available from local suppliers.

X1.34 Cooling System Cleanser or Premixed Coolant Flush Chemicals:
Oxalic acid, 55-lb bags
Sodium Carbonate, 50-lb bags:
Ashland Chemical Company
P.O. Box 391
Ashland, KY 41114
Telephone: (606) 329-5044

Petro Dispersant No. 425 Powder, 50-lb bags:
Witco Corporation
3230 Brookfield
Houston, TX 77045
Telephone: 1-800-231-1542 (Outside Texas)
1-800-391-1681 (Inside Texas)

Oxalic Acid 17.5 g/L (2.3 oz/gal) and Petro Dispersant No. 425 1 g/L (0.15 oz/gal) premixed in a single use container:
Wrico Corporation
4835 Whirlwind
San Antonio, TX 78217
Attn: President

Telephone: (210) 590-4400
Fax: (210) 590-4451

X1.35 Engine Mounts:
Lybrook Precision Products
Telephone: (313) 946-4246

X1.36 Engine Mount Isolators (Biscuits):
World Class Engineered Products
20994 Bridge Street
Southfield, MI 48034
Telephone: (313) 351-4090
Fax: (313) 351-4099

X1.37 Test Fuel:
Haltermann Products
1201 South Sheldon Road
P.O. Box 429
Channelview, TX 77530-0429
Telephone: 832-376-2213
Fax: 281-457-1469

X1.38 Order parts specified as “available from CPD” from:
Test Engineering, Inc. (TEI)
12758 Cimarron Path, Suite 102
San Antonio, Texas 78249-3417

ASTM International takes no position respecting the validity of any patent rights asserted in connection with any item mentioned in this standard. Users of this standard are expressly advised that determination of the validity of any such patent rights, and the risk of infringement of such rights, are entirely their own responsibility.

This standard is subject to revision at any time by the responsible technical committee and must be reviewed every five years and if not revised, either reapproved or withdrawn. Your comments are invited either for revision of this standard or for additional standards and should be addressed to ASTM International Headquarters. Your comments will receive careful consideration at a meeting of the responsible technical committee, which you may attend. If you feel that your comments have not received a fair hearing you should make your views known to the ASTM Committee on Standards, at the address shown below.

This standard is copyrighted by ASTM International, 100 Barr Harbor Drive, PO Box C700, West Conshohocken, PA 19428-2959, United States. Individual reprints (single or multiple copies) of this standard may be obtained by contacting ASTM at the above address or at 610-832-9585 (phone), 610-832-9555 (fax), or service@astm.org (e-mail); or through the ASTM website (www.astm.org).