



Standard Test Method for Determination of Grain Stability of Calcined Petroleum Coke¹

This standard is issued under the fixed designation D 6791; the number immediately following the designation indicates the year of original adoption or, in the case of revision, the year of last revision. A number in parentheses indicates the year of last reapproval. A superscript epsilon (ϵ) indicates an editorial change since the last revision or reapproval.

1. Scope

1.1 This test method covers a laboratory vibration mill method for the determination of the grain stability of calcined coke for the manufacture of carbon products used in the smelting of aluminum. Calcined coke with poor mechanical strength may become degraded during mixing. Poor grain stability will affect the grain size and may result in poor quality of baked blocks.

1.2 The values stated in acceptable metric units are to be regarded as the standard.

1.3 *This standard does not purport to address all of the safety concerns, if any, associated with its use. It is the responsibility of the user of this standard to establish appropriate safety and health practices and determine the applicability of regulatory limitations prior to use.*

2. Referenced Documents

2.1 ASTM Standards:

D 346 Practice for Collection and Preparation of Coke Samples for Laboratory Analysis²

D 2013 Method of Preparing Coal Samples for Analysis²

D 2234 Test Methods for Collection of a Gross Sample of Coal²

E 11 Specification for Wire-Cloth Sieve for Testing Purposes³

2.2 ISO Standard:⁴

ISO 6375 Carbonaceous Materials for the Production of Aluminum—Coke for Electrodes—Sampling

3. Terminology

3.1 Definitions:

3.1.1 *calcined petroleum coke*—green petroleum coke that has been thermally treated to drive off the volatile matter and to develop crystalline structure.

3.1.2 *petroleum coke*—a solid, carbonaceous residue pro-

duced by thermal decomposition of heavy petroleum fractions or cracked stocks, or both.

4. Summary of Test Method

4.1 A representative sample of calcined petroleum coke is dried and screened to a 4 mm to 8 mm fraction. The resultant sample is weighed so that two separate portions of $100.0 \text{ g} \pm 0.5 \text{ g}$ mass are obtained. The samples are placed into the laboratory mill and ground for a specified period of time. After grinding the sample is screened and the mass of the +4 mm material is determined. The grain stability is the percent of the original material remaining on the +4 mm sieve.

5. Significance and Use

5.1 The grain stability of calcined petroleum coke determines the resistance to breakdown of +4 mm particles used in the manufacture of carbon anodes for use in the reduction process of aluminum.

5.2 Cokes have to be relatively easy to grind for fines production but strong enough to withstand forming pressures and thermal stresses occurring when the anodes are used in the reduction process.

6. Interferences

6.1 No material normally applied to the calcined petroleum coke is found to cause analytical interference with this procedure.

7. Apparatus

7.1 *Analytical Balance*, accurate to $\pm 0.1 \text{ g}$.

7.2 *Rifflers*, with hoppers and closures.

7.3 *Wire Sieves*, 8 mm ($5/16$ in.) and 4 mm (5 mesh), meeting Specification E 11.

7.4 *Laboratory Vibration Mill*⁵, having two grinding vessels, each filled with 1 kg of clean, hard steel balls, diameter $10 \text{ mm} \pm 0.4 \text{ mm}$. The main features of the mill are shown in Figs. 1-5.

7.4.1 The mill and drive motor are mounted on a common

¹ This test method is under the jurisdiction of ASTM Committee D02 on Petroleum Products and Lubricants and is the direct responsibility of Subcommittee D02.05.0D on Petroleum Coke.

Current edition approved April 10, 2002. Published August 2002.

² *Annual Book of ASTM Standards*, Vol 05.06.

³ *Annual Book of ASTM Standards*, Vol 14.02.

⁴ Available from American National Standards Institute, 25 W. 43rd St., 4th Floor, New York, NY 10036.

⁵ The sole source of supply of the vibration mill is Siebtechnik GmbH, P.O. Box/Postfach 10 17 51, D-25417 MUELHEIM an der RUHR, Germany. If you are aware of alternative suppliers, please provide this information to ASTM International Headquarters. Your comments will receive careful consideration at a meeting of the responsible technical committee¹ which you may attend.

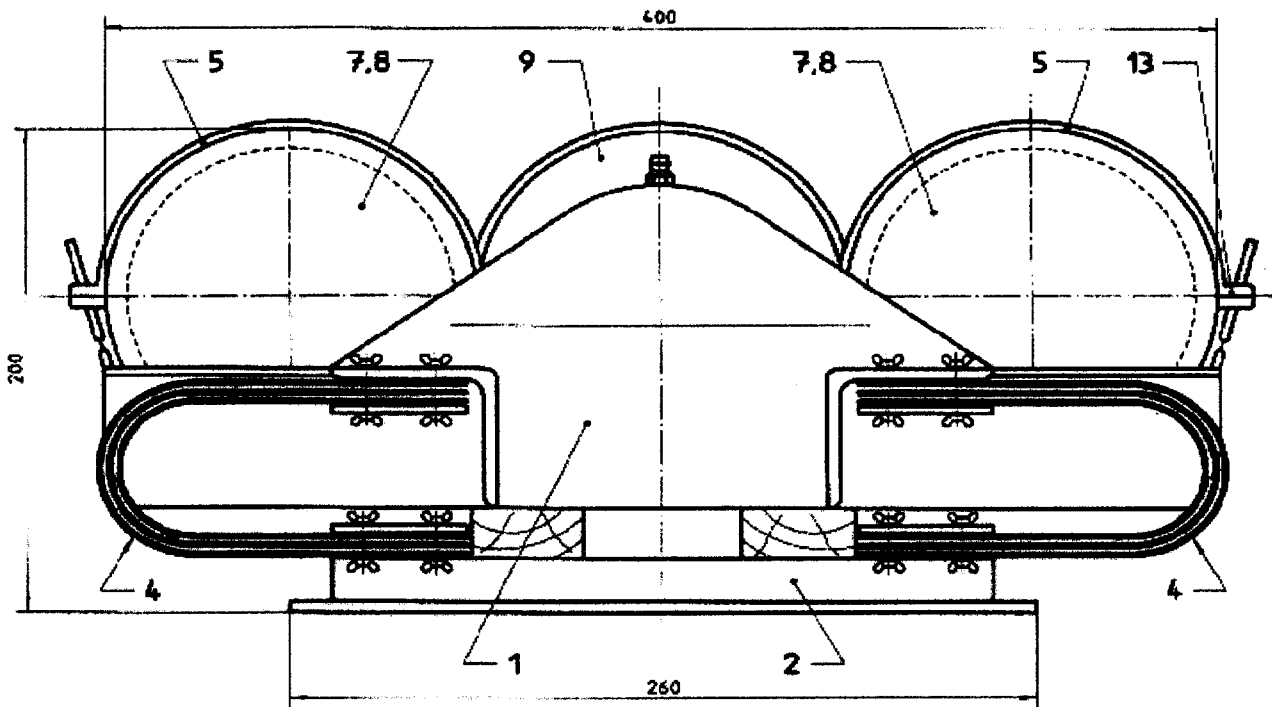

- 1 = mill
- 2 = common base plate
- 4 = flat springs
- 5 = adjustable straps
- 7,8 = grinding vessels
- 9 = motor
- 13 = quick release catch

NOTE—All dimensions are in millimetres.

FIG. 1 Laboratory Vibration Mill (Front View)

base plate. The grinding vessels are installed in the body of the mill, which is supported by four soft, flat springs. The spring suspension system is designed to allow the machine to be operated without any fastenings or anchorage. The grinding vessels are secured by adjustable straps which have a quick-release catch. The oscillator is supported on a bearing, fitted to the body of the mill, and is driven by the motor by way of a special clutch and a hollow flexible shaft.

7.4.2 The peak-to-peak amplitude of the vibration shall be $4 \text{ mm} \pm 0.5 \text{ mm}$. A reference disc is fitted to the front of the machine to measure the amplitude of vibration.

7.4.3 The motor shall be capable of 1450 rpm to 1470 rpm. The motor may be set up for 50 HZ rather than 60 HZ power. A tachometer can be used to verify that the motor is the specified RPM. The motor speed can be regulated with a DC speed controller to adjust it to the specified RPM. The bearing housing is rigidly connected to the bearings. The shaft rotates inside the bearings with two steel imbalance discs attached and is connected to the motor by way of the clutch. The imbalance discs are shown in Fig. 4.

7.4.4 The imbalance discs rotate eccentrically and the entire oscillating mass follows with a phase lag of 180° , supported by the springs. Each grinding vessel (see Fig. 5) has a total volume of 1 L and an effective volume of 0.3 L. It is closed by a lid

with a rubber sealing ring. The lid is held in place by a clamp fitted with a wing nut.

7.4.5 The electric motor is linked to a timer switch having a precision of $\pm 2 \text{ s}$.

8. Sample Preparation

8.1 For recommended practice for obtaining, handling, and preparing coke samples, refer to Test Methods D 346, D 2013, D 2234 and ISO 6375. Do not precrush the sample. Sieve the sample to collect 200 g of coke of grain size between 4 mm and 8 mm.

9. Procedure

9.1 Carefully place 1 kg of the steel balls and $100 \text{ g} \pm 0.5 \text{ g}$ of the 4 mm to 8 mm fraction of the sieved test sample in each grinding vessel and close the lid. Record the weight to the nearest 0.1 g. Attach the vessels to the vibration mill.

9.2 Turn the mill on and grind the sample for $3.5 \text{ min} \pm 2 \text{ s}$ as measured by the timer switch.

9.3 Carefully empty the contents of one vessel on to an 8-mm sieve, placed on top of a 4-mm sieve. Screen by hand, using approximately 60 horizontal movements in about half a minute. The steel balls will remain on the 8-mm sieve, and part of the granular material will remain on the 4-mm sieve.

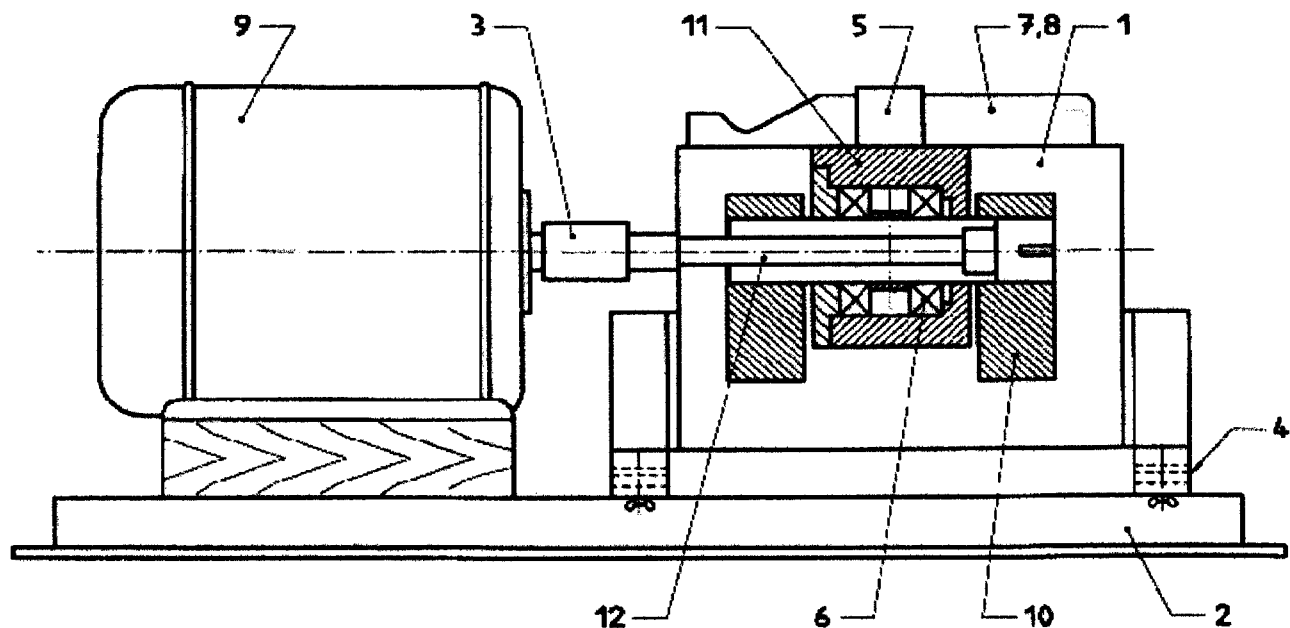

- 2 = common baseplate
- 3 = special clutch
- 4 = flatsprings
- 5 = adjustable straps
- 6 = bearing
- 7,8 = grinding vessels
- 9 = motor
- 10 = discs
- 11 = bearing housing
- 12 = shaft

FIG. 2 Laboratory Vibration Mill (Side View)

9.4 Weigh the portion of granular material that remains on the 4-mm sieve to the nearest 0.01 g and record as vessel 1, m_3 .

9.5 Repeat with the contents of the other vessel and record as vessel 2, m_4 .

10. Calculation

10.1 The grain stability (GS) of the calcined coke, expressed in percent, is given by the equation:

$$GS = \frac{GS_1 + GS_2}{2} = \frac{1}{2} \left[\frac{m_3}{m_1} + \frac{m_4}{m_2} \right] \times 100 \quad (1)$$

where:

- GS_1 = grain stability for vessel 1 in %,
- GS_2 = grain stability for vessel 2 in %,
- m_1 = mass of test sample placed in vessel 1, g,
- m_2 = mass of test sample placed in vessel 2, g,
- m_3 = mass of test sample from vessel 1 retained on the 4 mm sieve, g, and
- m_4 = mass of test sample from vessel 2 retained on the 4 mm sieve, g.

10.2 If GS_1 and GS_2 differ by less than $\sqrt{2} \times$ the repeatability of the test method, report the result, GS , as the mean of the simultaneous duplicate determinations GS_1 and GS_2 , to the nearest 0.01 %.

10.3 If GS_1 and GS_2 differ by more than $\sqrt{2} \times$ the repeatability of the test method, repeat the procedure detailed

in Section 10. Reject all the results.

11. Report

11.1 Report the average of the two vessels to the nearest whole percent.

12. Precision and Bias

12.1 The precision of this test method as determined by the statistical examination of interlaboratory test results is as follows:

12.1.1 *Repeatability*—The difference between successive results by the same operator using the same apparatus under constant operating conditions on the identical test materials, will in the long run, in normal and correct operation of the test method, exceed the following values only in one case in twenty.

12.1.1.1 Individual results should not differ by more than 2 %.

12.1.2 *Reproducibility*—The difference between two single and independent results obtained by different laboratories on identical test materials will in the long run, in normal and correct operation of the test method, exceed the following values only in one case in twenty.

12.1.2.1 Individual results should not differ by more than 3 %.

12.1.3 *Bias*—Since there is not accepted reference material

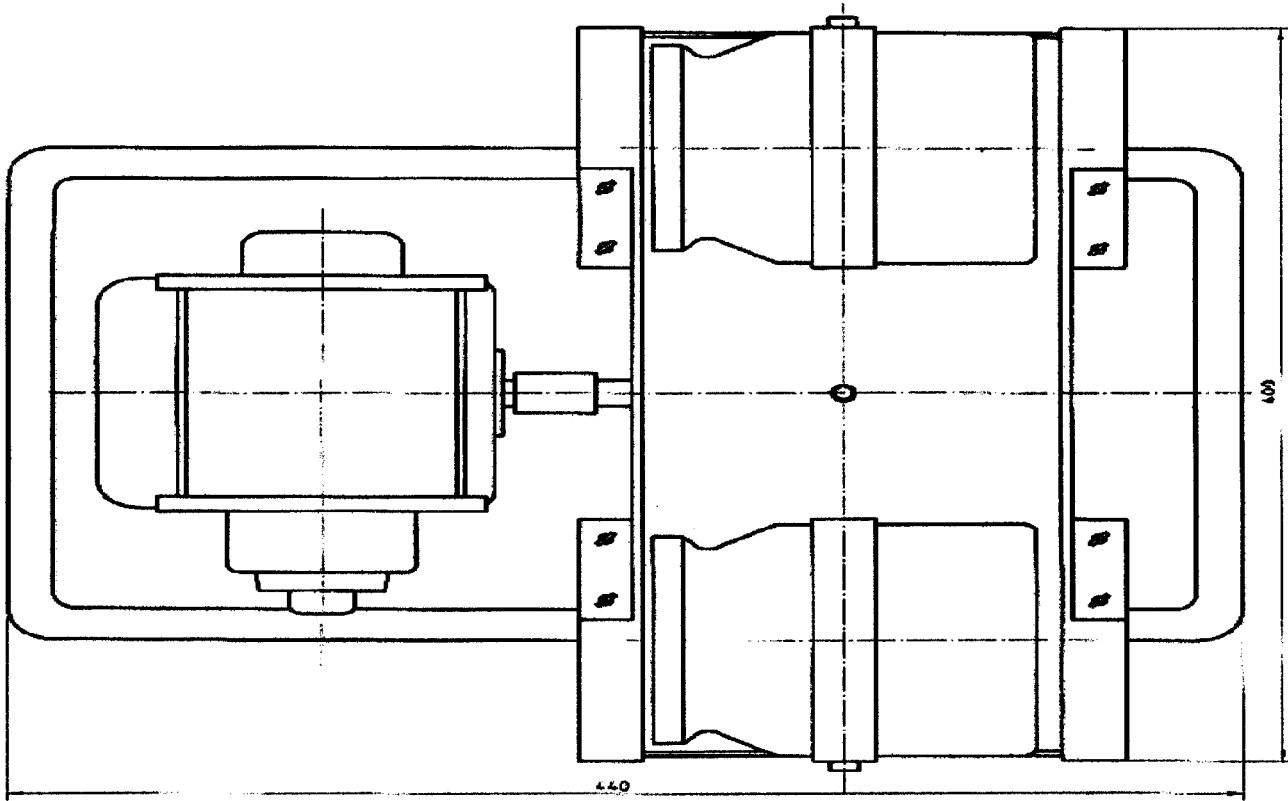

NOTE—All dimensions are in millimetres.
FIG. 3 Laboratory Vibration Mill (Ground Plan)

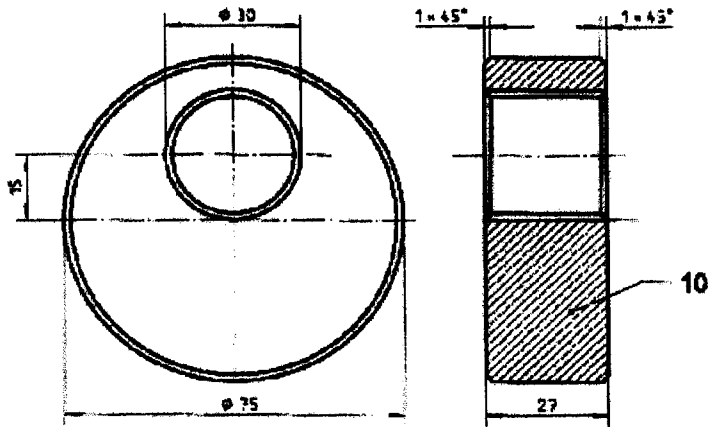

10 = discs

NOTE—All dimensions are in millimetres.
FIG. 4 Imbalance Discs

suitable for determining the bias for the procedure in this test method, no statement on bias is being made.

13. Keywords

13.1 calcined petroleum coke; grain stability

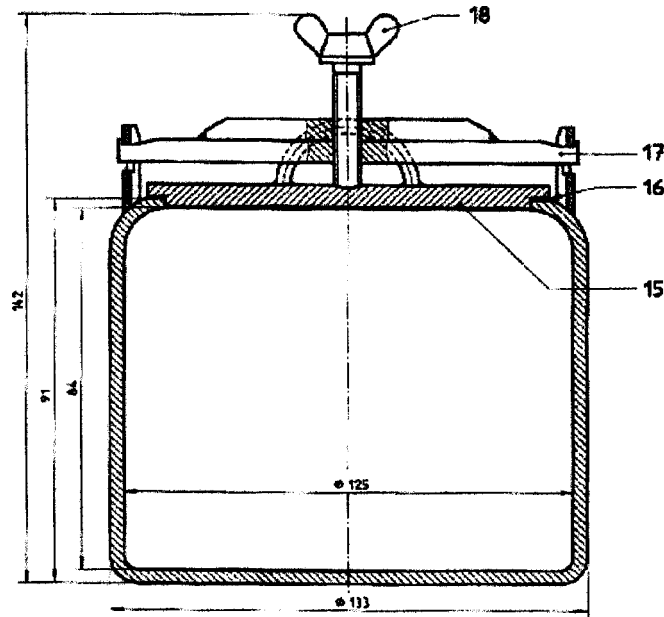

- 15 = lid
- 16 = rubber sealing ring
- 17 = clamp
- 18 = wing nut

NOTE—All dimensions are in millimetres.

FIG. 5 Grinding Vessel

ASTM International takes no position respecting the validity of any patent rights asserted in connection with any item mentioned in this standard. Users of this standard are expressly advised that determination of the validity of any such patent rights, and the risk of infringement of such rights, are entirely their own responsibility.

This standard is subject to revision at any time by the responsible technical committee and must be reviewed every five years and if not revised, either reapproved or withdrawn. Your comments are invited either for revision of this standard or for additional standards and should be addressed to ASTM International Headquarters. Your comments will receive careful consideration at a meeting of the responsible technical committee, which you may attend. If you feel that your comments have not received a fair hearing you should make your views known to the ASTM Committee on Standards, at the address shown below.

This standard is copyrighted by ASTM International, 100 Barr Harbor Drive, PO Box C700, West Conshohocken, PA 19428-2959, United States. Individual reprints (single or multiple copies) of this standard may be obtained by contacting ASTM at the above address or at 610-832-9585 (phone), 610-832-9555 (fax), or service@astm.org (e-mail); or through the ASTM website (www.astm.org).