



Standard Test Method for Rust-Preventing Characteristics of Inhibited Mineral Oil in the Presence of Water¹

This standard is issued under the fixed designation D 665; the number immediately following the designation indicates the year of original adoption or, in the case of revision, the year of last revision. A number in parentheses indicates the year of last reappraisal. A superscript epsilon (ϵ) indicates an editorial change since the last revision or reappraisal.

This standard has been approved for use by agencies of the Department of Defense.

1. Scope

1.1 This test method covers the evaluation of the ability of inhibited mineral oils, particularly steam-turbine oils, to aid in preventing the rusting of ferrous parts should water become mixed with the oil. This test method is also used for testing other oils, such as hydraulic oils and circulating oils. Provision is made in the procedure for testing heavier-than-water fluids.

NOTE 1—For synthetic fluids, such as phosphate ester types, the plastic holder and beaker cover should be made of a chemically resistant material, such as polytetrafluoroethylene (PTFE).

1.2 *This standard does not purport to address all of the safety concerns, if any, associated with its use. It is the responsibility of the user of this standard to establish appropriate safety and health practices and determine the applicability of regulatory limitations prior to use.* For specific warning statements, see 6.4-6.6.

2. Referenced Documents

2.1 ASTM Standards:²

- A 108 Specification for Steel Bars, Carbon, Cold-Finished, Standard Quality
- A 240/A 240M Specification for Chromium and Chromium-Nickel Stainless Steel Plate, Sheet, and Strip for Pressure Vessels and for General Applications
- D 91 Test Method for Precipitation Number of Lubricating Oils
- D 1193 Specification for Reagent Water

- D 2422 Classification of Industrial Fluid Lubricants by Viscosity System
- D 3603 Test Method for Rust-Preventing Characteristics of Steam Turbine Oil in the Presence of Water (Horizontal Disk Method)
- D 4057 Practice for Manual Sampling of Petroleum and Petroleum Products
- E 1 Specification for ASTM Thermometers
- Motor Fuels, Section I, Annex A2, Table 32, Reference Materials and Blending Accessories³
- 2.2 *Other Documents:*
 - Specifications-IP Standard Thermometers, Appendix A⁴
 - Specifications for IP Standard Reference Liquids, Appendix B⁴
 - SAE Standard J405 Chemical Composition of SAE Wrought Stainless Steels⁵
 - BS 871 Specification for abrasive papers and cloths⁴
 - BS 970: Part 1: Carbon and Carbon Manganese Steels Including Free Cutting Steels⁴

3. Summary of Test Method

3.1 A mixture of 300 mL of the oil under test is stirred with 30 mL of distilled water or synthetic sea water, as required, at a temperature of $60 \pm 1^\circ\text{C}$ ($140 \pm 2^\circ\text{F}$) with a cylindrical steel test rod completely immersed therein. It is recommended to run the test for 4 h; however, the test period may, at the discretion of the contracting parties, be for a shorter or longer period. The test rod is observed for signs of rusting and, if desired, degree of rusting.

¹ This test method is under the jurisdiction of ASTM Committee D02 on Petroleum Products and Lubricants and is the direct responsibility of Subcommittee D02.C0 on Turbine Oils.

Current edition approved Nov. 1, 2003. Published November 2003. Originally approved in 1942. Last previous edition approved in 2002 as D 665-02.

In the IP, this test method is under the jurisdiction of the Standardization Committee. This test method was adopted as a joint ASTM-IP standard in 1964.

² For referenced ASTM standards, visit the ASTM website, www.astm.org, or contact ASTM Customer Service at service@astm.org. For *Annual Book of ASTM Standards* volume information, refer to the standard's Document Summary page on the ASTM website.

³ See 1996 *Annual Book of ASTM Standards*, Vol 05.04.

⁴ *Annual Book of IP Standard Methods for Analysis and Testing of Petroleum and Related Products*, Vol 2.

⁵ 1995 *SAE Handbook*, Vol 1.

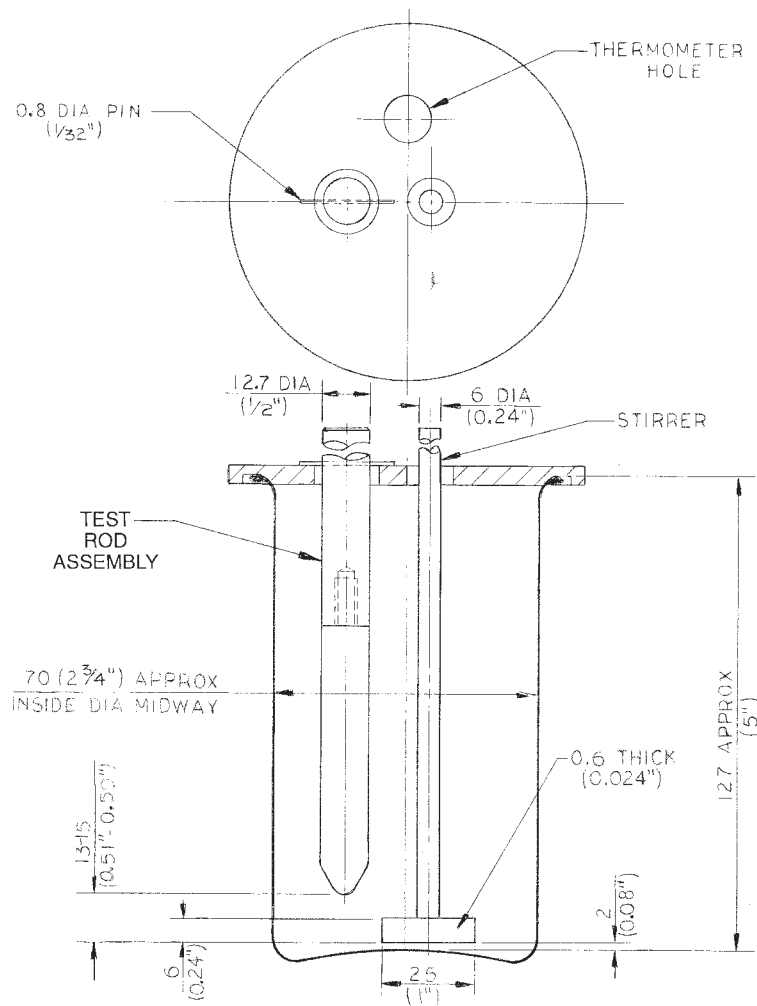

NOTE—All units are in millimetres, unless otherwise specified.

FIG. 1 Rusting Test Apparatus

NOTE 2—Until 1999 it was customary to run the test for 24 h. A round robin with comparisons of different test times showed that no statistically significant differences in rating were found for any sample, between the 4 and 24 h results.⁶

4. Significance and Use

4.1 In many instances, such as in the gears of a steam turbine, water can become mixed with the lubricant, and rusting of ferrous parts can occur. This test indicates how well inhibited mineral oils aid in preventing this type of rusting. This test method is also used for testing hydraulic and circulating oils, including heavier-than-water fluids. It is used for specification of new oils and monitoring of in-service oils.

NOTE 3—This test method was used as a basis for Test Method D 3603. Test Method D 3603 is used to test the oil on separate horizontal and vertical test rod surfaces, and can provide a more discriminating evaluation.

5. Apparatus

5.1 *Oil Bath*—A thermostatically controlled liquid bath capable of maintaining the test sample at a temperature of $60 \pm 1^\circ\text{C}$ ($140 \pm 2^\circ\text{F}$) (see Note 4). An oil having a viscosity of approximately ISO VG 32 (see Classification D 2422) is suitable for the bath. The bath shall have a cover with holes to accommodate the test beakers.

NOTE 4—ASTM Thermometer 9C (9F), as prescribed in Specification E 1, or IP Thermometer 21C in accordance with IP Volume 2, Appendix A, is suitable to indicate the temperature. Alternatively, calibrated thermocouples may be used.

5.2 *Beaker*—A 400-mL, Berzelius-type, tall-form heat-resistant glass⁷ beaker without pourout, as shown in Fig. 1, approximately 127 mm (5 in.) in height measured from the inside bottom center and approximately 70 mm ($2\frac{3}{4}$ in.) in inside diameter measured at the middle.

5.3 *Beaker Cover*—A flat beaker cover of glass or poly (methyl methacrylate) (PMMA) (Note 5), kept in position by

⁶ Supporting data (results of the cooperative test program with modified test duration) have been filed at ASTM International Headquarters and may be obtained by requesting Research Report RR: D02-1474.

⁷ Borosilicate glass is satisfactory for this purpose.

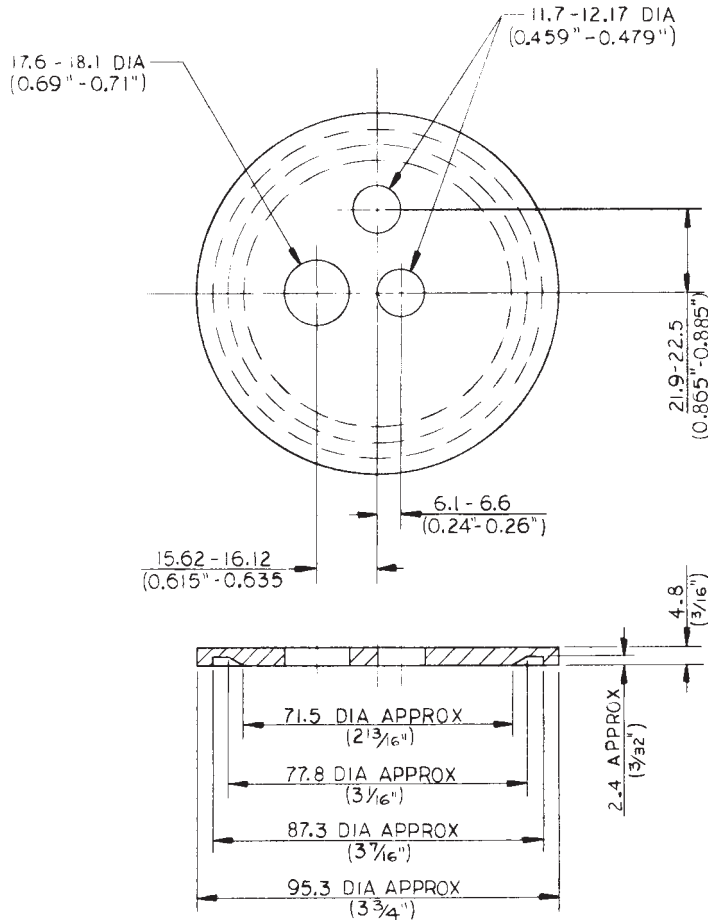

NOTE—All units are in millimetres, unless otherwise specified.

FIG. 2 Beaker Cover

suitable means such as a rim or groove. Two holes shall be provided on any diameter of the cover; one for a stirrer 12 mm ($15/32$ in.) in diameter with its center 6.4 mm ($1/4$ in.) from the center of the cover; and the other, on the opposite side of the center of the cover, for the test rod assembly (see Section 8), 18 mm ($45/64$ in.) in diameter with its center 16 mm ($5/8$ in.) from the center of the cover. In addition, a third hole 12 mm ($15/32$ in.) in diameter shall be provided for a temperature measuring device, with its center 22.5 mm ($7/8$ in.) from the center of the cover and on a diameter of the cover at right angles to the diameter through the other two holes.

NOTE 5—An inverted petri dish makes a suitable cover, as the sides of the dish aid in keeping it in position. Fig. 2 shows a PMMA resin cover for the beaker which has been found to be suitable. An optional feature is shown, consisting of a slot, 1.6 by 27 mm ($1/16$ by $1 1/16$ in.), which is centered on a diameter of the stirrer hole at right angles to the cover diameter through the test rod hole and stirrer hole. This feature allows withdrawal of the stirrer while the beaker cover is in place. When the test method test is used for other fluids such as synthetics, the beaker cover should be made from chemically resistant material such as polymonochlorotrifluoroethylene (PCTFE).

5.4 The plastic holder shall be made of PMMA resin in accordance with the dimensions shown in Fig. 3 (two types of

holders are illustrated). When testing synthetic fluids, the plastic holder should be made from chemically resistant material such as polytetrafluoroethylene (PTFE).

5.5 *Stirrer*—A stirrer constructed entirely from stainless steel (Note 6 and Note 7) in the form of an inverted T. A flat blade 25 by 6 by 0.6 mm (1 by 0.24 by 0.024 in.) shall be attached to a 6-mm (0.24-in.) rod in such a way that the blade is symmetrical with the rod and has its flat surface in the vertical plane.

NOTE 6—A suitable material is an 18 % chromium, 8 % nickel alloy steel conforming to Type 304, of Specification A 240/A 240M, or SAE No. 30304 (see SAE J405), or BS 970: Part 1: 1983: 302S31.

NOTE 7—If stainless steel is not obtainable, stirrers made of heat-resistant glass⁷ and having approximately the same dimensions as the stainless steel stirrers specified can be used.

5.6 *Stirring Apparatus*—Any convenient form of stirring apparatus capable of maintaining a speed of 1000 ± 50 rpm.

5.7 *Grinding and Polishing Equipment*—A 150-grit (99- μ m) and a 240-grit (53.5- μ m) in accordance with BS 871 or its equivalent, metalworking aluminum oxide abrasive cloth coat

TEST ROD HOLDERS

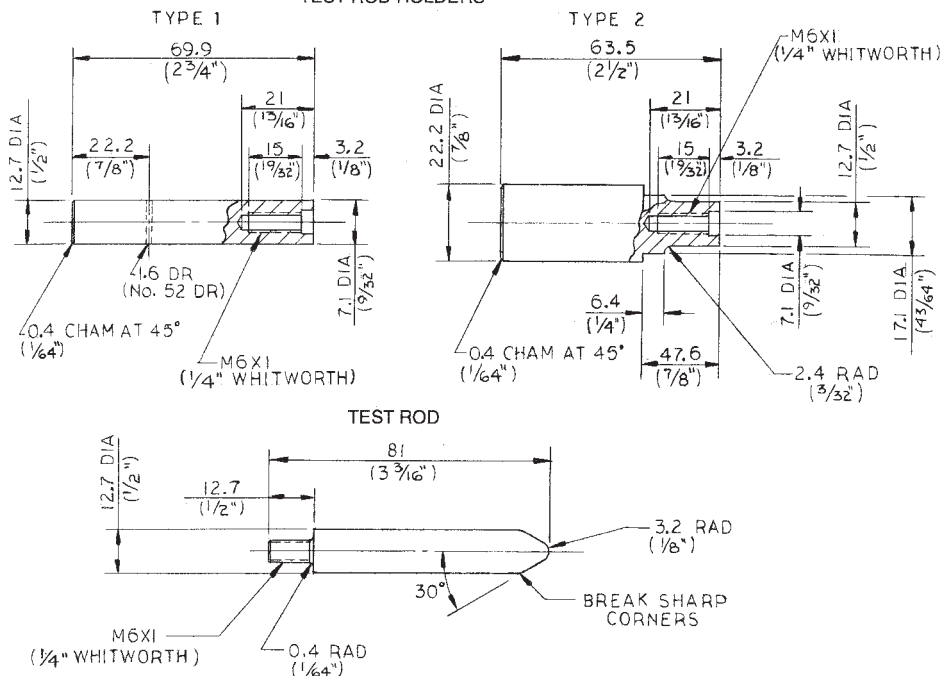

NOTE—All units are in millimetres, unless otherwise specified.

FIG. 3 Test Rod and Holders

on a jeans backing, a suitable chuck (see Fig. 4) for holding the test rod, and a means of rotating the test rod at a speed of 1700 to 1800 rpm.

5.8 *Oven*, capable of maintaining a temperature of 65°C (150°F).

6. Reagents and Materials

6.1 *Purity of Reagents*—Reagent grade chemicals shall be used in all tests. Unless otherwise indicated, it is intended that all reagents conform to the specifications of the Committee on Analytical Reagents of the American Chemical Society where such specifications are available.⁸ Other grades may be used, provided it is first ascertained that the reagent is of sufficiently high purity to permit its use without lessening the accuracy of the determination.

6.2 *Purity of Water*—Unless otherwise indicated, references to water shall be understood to mean reagent water as defined by Type II of Specification D 1193.

6.3 The synthetic sea water shall have the following composition:

Salt	g/L
NaCl	24.54
MgCl ₂ ·6H ₂ O	11.10
Na ₂ SO ₄	4.09
CaCl ₂	1.16
KCl	0.69
NaHCO ₃	0.20
KBr	0.10
H ₃ BO ₃	0.03
SrCl ₂ ·6H ₂ O	0.04
NaF	0.003

6.3.1 The solution can be conveniently prepared as follows. This procedure avoids any precipitation in concentrated solutions with subsequent uncertainty of complete resolution. Using certified pure (cp) chemicals and distilled water, prepare the following stock solutions:

Stock Solution No. 1:

MgCl ₂ ·6H ₂ O	3885 g
CaCl ₂ (anhydrous)	406 g
SrCl ₂ ·6H ₂ O	14 g
Dissolve and dilute to 7 L	

Stock Solution No. 2:

KCl	483 g
NaHCO ₃	140 g
KBr	70 g
H ₃ BO ₃	21 g
NaF	2.1 g
Dissolve and dilute to 7 L	

⁸ *Reagent Chemicals, American Chemical Society Specifications*, American Chemical Society, Washington, DC. For suggestions on the testing of reagents not listed by the American Chemical Society, see *Analar Standards for Laboratory Chemicals*, BDH Ltd., Poole, Dorset, U.K., and the *United States Pharmacopeia and National Formulary*, U.S. Pharmacopeial Convention, Inc. (USPC), Rockville, MD.

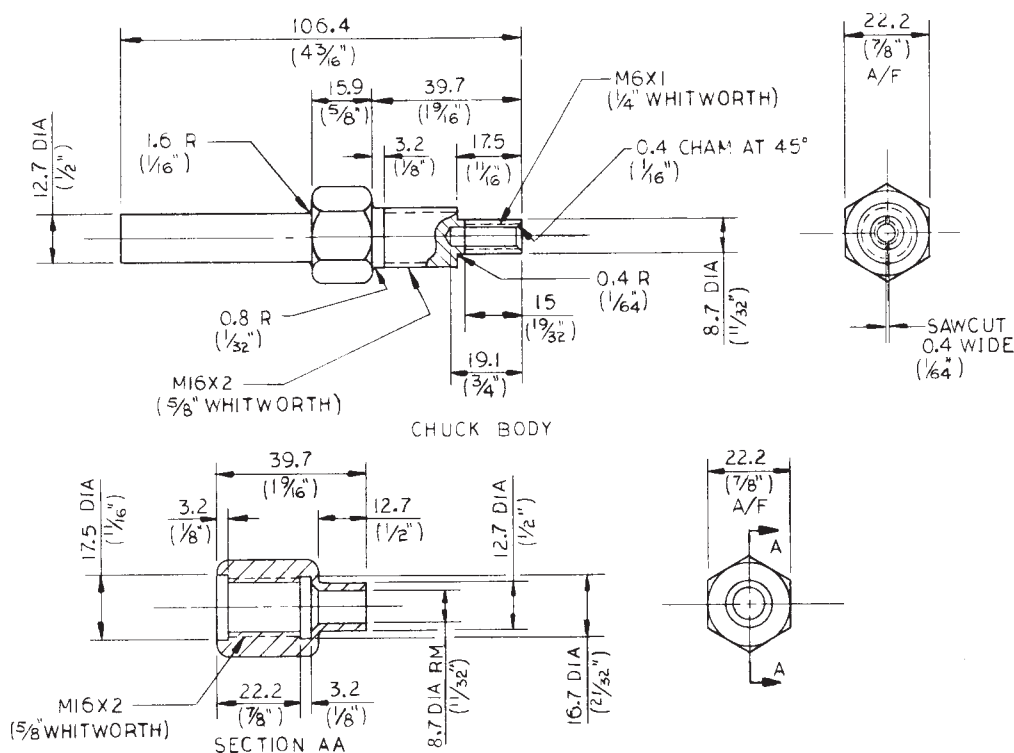

NOTE—All units are in millimetres, unless otherwise specified.

FIG. 4 Chuck for Polishing Test Rods

6.3.2 To prepare the synthetic sea water, dissolve 245.4 g of NaCl and 40.94 g of Na₂SO₄ in a few litres of distilled water, add 200 mL of Stock Solution No. 1 and 100 mL of Stock Solution No. 2 and dilute to 10 L. Stir the 10-L batch and add 0.1 N Na₂CO₃ solution until the pH is between 7.8 and 8.2. One or two millilitres of the carbonate solution will be required.

6.4 *Precipitation Naphtha*, as specified in Test Method D 91. (**Warning**—Flammable. Health hazard.)

6.5 *Isooctane*, as specified in Table 32, Motor Fuels Section I, Annex A2, Reference Materials and Blending Accessories. (**Warning**—Flammable. Health hazard.)

6.6 *IP 60/80 Petroleum Spirit*, as specified by IP Standard Reference Liquids. (**Warning**—Flammable. Health hazard.)

6.7 *Steel Test Rod*, as specified in Section 8.

7. Sampling

7.1 Sample for this test can come from tanks, drums, small containers, or even operating equipment, and they should be truly representative of the entire quantity. Therefore, use the applicable apparatus and techniques described in Practice D 4057, or other comparable standard practice.

8. Test Rod and Its Preparation

8.1 For each test oil, prepare two steel test rods. These may either be new or from a previous test (see Note 8) and shall be prepared in accordance with 8.2 and 8.3.

8.2 The test rod assembly shall consist of a round steel test rod fitted to a plastic holder. The round steel test rod, when new, shall be 12.7 mm (0.5 in.) in diameter and approximately

68 mm (2 11/16 in.) in length exclusive of the threaded portion which screws into the plastic holder and shall be tapered at one end as shown in Fig. 3. It shall be made of steel conforming to Grade 10180 of Specification A 108 or to BS 970 Part I: 1983-070M20. If these steels are not available, other equivalent steels may be used, provided they are found to be satisfactory by comparative test using this Test Method D 665 - IP 135.

NOTE 8—When making a check test, the steel test rod that showed rust should not be reused. Test rods that repeatedly show rust in tests of various oils can be imperfect. Such test rods should be used with oils known to pass the test. If rusting occurs in repeat tests, these test rods should be discarded.

8.3 *Preliminary Grinding*—If the test rod has been used previously and is free of rust or other irregularities, the preliminary grinding may be omitted, and it may be subjected only to final polishing as prescribed in 8.4. If the test rod is new or if any part of its surface shows rust or other irregularities, clean it with ASTM precipitation naphtha or *isooctane* or IP 60/80 petroleum spirit and grind with medium 150-grit aluminum oxide cloth to remove all irregularities, pits, and scratches, as determined by visual inspection (Note 9). Perform the grindings by mounting the test rod in the chuck of the grinding and polishing apparatus, and turning it at a speed of 1700 to 1800 rpm while applying the 150-grit aluminum oxide cloth. Old 150-grit aluminum oxide cloth may be used to remove rust or major irregularities, but complete the grinding with new cloth. Proceed at once with the final polishing with 240-grit aluminum oxide cloth, or remove the test rod from the chuck

and store in *isooctane* until needed. Discard reused test rods when the diameter is reduced to 9.5 mm (0.375 in.).

NOTE 9—Do not touch the test rods with the hands at any stage after cleaning with naphtha or *isooctane* or the petroleum spirit (which precedes either preliminary grinding or final polishing) until the test is completed. Forceps or a clean, lintless cloth may be used.

8.4 Final Polishing:

8.4.1 Just before the test is to be made, subject the test rod to final polishing with 240-grit aluminum oxide cloth. If the preliminary grinding has just been completed, stop the motor that rotates the test rod. Otherwise, remove the test rod from the *isooctane* (previously used unruled test rods shall be stored in this reagent), dry with a clean cloth, and place in the chuck. Rub a new piece of 240-grit aluminum oxide cloth longitudinally over the static test rod until the rounded end, and the entire surface show visible scratches. Rotate the test rod at a speed of 1700 to 1800 rpm. Take the cloth and place it halfway around the test rod, and apply a firm but gentle downward pull to the loose ends of the cloth for about 1 to 2 min so as to produce a uniform finely scratched surface free of longitudinal scratches. Carry out the final stages of the polishing with new cloth.

8.4.2 To ensure that the flat shoulder (that portion of the test rod perpendicular to the threaded stem) is free of rust, polish this area. This can be done by holding a strip of 240-grit aluminum oxide cloth between the chuck and the shoulder while rotating the test rod for a brief period.

8.4.3 Remove the test rod from the chuck without touching with the fingers; wipe lightly with a clean, dry, lintless cloth or tissue (or brush the test rod lightly with a camel's hair brush); attach to the plastic holder; and immediately immerse in the oil to be tested. This can be either the hot oil sample (see 9.1) or a clean test tube containing a portion of the sample. The test rod can be removed later from this tube and allowed to drain briefly before being placed in the hot oil.

9. Procedure A for Distilled Water

9.1 Clean the beaker in accordance with good laboratory procedure, wash with distilled water, and dry in an oven. Clean glass beaker cover and a glass stirrer by the same procedure. To clean a stainless steel stirrer and a PMMA cover, use ASTM precipitation naphtha or *isooctane* or IP 60/80 petroleum spirit, wash thoroughly with hot water and finally with distilled water, and dry in an oven at a temperature not over 65°C (150°F). Pour 300 mL of the oil to be tested (see Practice D 4057) into the beaker and place the beaker in the oil bath held at a temperature that will maintain the oil sample at $60 \pm 1^\circ\text{C}$ ($140 \pm 2^\circ\text{F}$). Insert the beaker into a hole of the bath cover and suspend in the hole with the beaker rim resting on the bath cover. The oil level in the bath shall not be below the oil level in the test beaker. Cover the beaker with the beaker cover with the stirrer in position in the proper opening. Adjust the stirrer so that the shaft is 6 mm (0.24 in.) off center in the beaker containing the oil sample and the blade is not more than 2 mm (0.08 in.) from the bottom of the beaker. Then suspend a temperature measuring device (see Note 10) through the hole in the cover intended for that purpose so that it is immersed to a depth of about 56 mm (2.2 in.). Start the stirrer and when the

temperature reading reaches $60 \pm 1^\circ\text{C}$ ($140 \pm 2^\circ\text{F}$), insert the steel test rod prepared in accordance with Section 8.

9.2 Insert the test rod assembly through the test rod hole in the beaker cover and suspend so that its lower end is 13 to 15 mm (0.51 to 0.59 in.) from the bottom of the beaker. Either type of plastic test rod holder (see Fig. 3) may be used. The hole through which the test rod is suspended shall be unobstructed (see Note 12).

NOTE 10—When analyzing multiple samples of a similar nature that are introduced into a thermostatically controlled bath at approximately the same time (that is, individual samples being analyzed as a batch), data collected has shown that it is not necessary to suspend a temperature measuring device through the hole in the cover intended for that purpose in each of the samples, since a thermostatically controlled bath is capable of maintaining the proper bath temperature within the allowed limits at each of the sample beaker locations. As such, it is permissible to suspend a temperature measuring device through the hole in the cover intended for that purpose in as few as one of the samples being analyzed, immersed to a depth of about 56 mm (2.2 in.). The temperature reading measured in the sample beaker location selected is the basis for determining when the temperature reaches $60 \pm 1^\circ\text{C}$ ($140 \pm 2^\circ\text{F}$) in order to begin stirring each of the beakers and inserting the steel test rods.

NOTE 11—In order not to disturb the thermal equilibrium in the oil bath once stirring of the samples has begun, no additional samples are to be added to the oil bath.

NOTE 12—Fig. 1 shows the arrangement of the apparatus.

9.3 Continue stirring for 30 min to ensure complete wetting of the steel test rod. With the stirrer in motion, remove the temperature measuring device (if applicable, see Note 10) temporarily and add 30 mL of distilled water through this hole, discharging the water on the bottom of the beaker, and replace the temperature measuring device (if applicable). Continue stirring at a speed of 1000 ± 50 rpm for 4 h (see Note 13) from the time water was added, maintaining the temperature of the oil-water mixture at $60 \pm 1^\circ\text{C}$ ($140 \pm 2^\circ\text{F}$). Stop stirring at the end of the 4-h period, remove the test rod, allow to drain, and then wash with ASTM precipitation naphtha or *isooctane*, or IP 60/80 petroleum spirit. If desired, the test rod may be preserved by lacquering.

NOTE 13—It is recommended to run the test for 4 h; however, the test period may, at the discretion of the contracting parties, be for a shorter or longer period.

10. Procedure B for Synthetic Sea Water

10.1 The procedure for rust-preventing characteristics of inhibited mineral oils in the presence of synthetic sea water shall be identical with that described in 9.1, 9.2, and 9.3, except use synthetic sea water in place of distilled water in that portion of the procedure described in 9.3.

11. Procedure C for Heavier-Than-Water Fluids

11.1 The stirring action provided by the stirrer prescribed in 5.5 is not sufficient to thoroughly mix the water and test sample when the fluid under test is heavier than water. This section is meant to define changes in the test method to accommodate heavier-than-water fluids. Except as specifically stated, all the requirements of the previous Sections 1-10 shall apply. Since this procedure can be performed with distilled water or synthetic sea water, take care to include this information in the report.

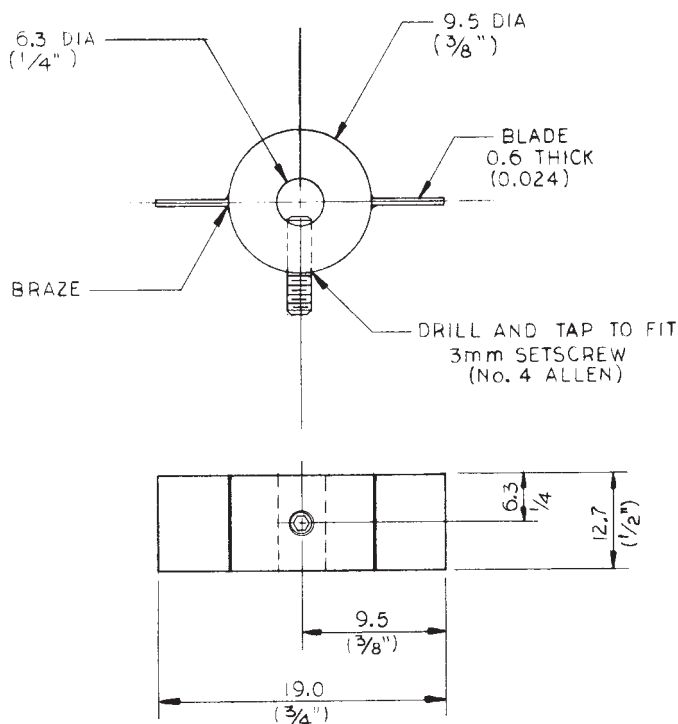

NOTE—All units are in millimetres, unless otherwise specified.

FIG. 5 Auxiliary Stirrer Blade (not to scale)

11.2 Apparatus:

11.2.1 *Beaker Cover*—Same as prescribed in 5.3 (see Note 14).

NOTE 14—Some heavier-than-water fluids can attack or dissolve PMMA beaker covers and test rod holders. It is recommended that PCTFE beaker covers and PTFE test rod holders be used when testing heavier-than-water fluids.

11.2.2 *Stirrer*—Same as prescribed in 5.5 but with an auxiliary blade attached to the stirrer shaft. The auxiliary blade shall be of stainless steel, 19.0 by 12.7 by 0.6 mm (0.75 by 0.50 by 0.025 in.) as shown in Fig. 5. The auxiliary blade shall be positioned on the stirrer shaft so that the bottom edge of the auxiliary blade is 57 mm (2.25 in.) above the top edge of the fixed lower blade, and so that the flat surfaces of both blades are in the same vertical plane.

11.3 *Test Rod and Its Preparation*—Same as prescribed in Section 8.

12. Interpretation of Results

12.1 Perform all inspections at the end of the test to determine the condition of test rods without magnification under normal light. For the purpose of this test, normal light is considered to be illumination of about 60 footcandles (650 lx). Within the meaning of this test method, a rusted test rod is one on which any rust spot or rust streak is visible by the above inspection procedure.

12.2 For the purpose of this test method, rust is an area of corrosion of the test surface that is identified by color and is confirmed by the presence of pits or roughness if the surface is wiped with a lintless cloth or tissue paper. Neither surface

discoloration nor specks, which can easily be removed with a lintless or tissue paper cloth with no evidence of pitting or roughness, shall be considered to be rust.

12.3 In order to report an oil as passing or failing, conduct the test in duplicate. Report an oil as passing the test if both test rods are rust-free at the end of the test period. Report an oil as failing the test if both test rods are rusted at the end of the test period (see Note 15). If one test rod is rusted while the other is free of rust, test two additional test rods (see Note 8). If either of these latter test rods shows rusting, report the oil as not passing the test. If neither of these latter test rods shows rusting, report the oil as passing the test.

NOTE 15—An indication of the degree of rusting occurring in this test may be desired. For uniformity in such cases, use of the following classifications of rusting severity is recommended:

Light Rusting—Rusting confined to not more than six spots, each of which is 1 mm or less in diameter.

Moderate Rusting—Rusting in excess of the above but confined to less than 5 % of the surface of the test rod.

Severe Rusting—Rusting covering more than 5 % of the surface of the test rod.

12.4 A reference oil with a Pass in Procedure A and a Fail in Procedure B can be prepared as follows: Add 0.0150 mass % of an additive concentrate⁹ to a white mineral oil.¹⁰ The additive concentrate consists of 60 mass % of dodeceny succinic acid and 40 mass % of normal paraffin oil, ISO VG 22 (see Classification D 2422).¹¹

13. Report

13.1 The test report shall contain the following:

13.1.1 The type and identification of the product used,

13.1.2 The date of the test,

13.1.3 A reference to this ASTM-IP standard, indicating whether Procedure A, B, or C was used. Since Procedure C may be followed with either distilled water or sea water, be sure to include the type of water used in this case,

13.1.4 The duration of the tests,

13.1.5 Any deviation from the procedure specified, and

13.1.6 The result of the test, including degree of severity of rusting, if desired.

14. Precision and Bias

14.1 No generally accepted method for determining precision or bias is currently available.¹¹

15. Keywords

15.1 circulating oils; heavier-than-water fluids; hydraulic oils; inhibited mineral oil; rust-preventing characteristics; steam-turbine oils

⁹ A suitable additive concentrate is Lubrizol 850, as used in the ASTM round robin. Lubrizol 850 is available from Lubrizol Corporation, Wickliffe, OH.

¹⁰ A suitable white mineral oil is USP Mineral Oil with a viscosity in the order of ISO VG 32 (Penreco Drakeol 19 was used in the ASTM round robin and is available from Penreco, Karns City, PA).

¹¹ Supporting data (results of the cooperative test program using this reference oil) have been filed at ASTM International Headquarters and may be obtained by requesting Research Report RR: D02-1284.

ASTM International takes no position respecting the validity of any patent rights asserted in connection with any item mentioned in this standard. Users of this standard are expressly advised that determination of the validity of any such patent rights, and the risk of infringement of such rights, are entirely their own responsibility.

This standard is subject to revision at any time by the responsible technical committee and must be reviewed every five years and if not revised, either reapproved or withdrawn. Your comments are invited either for revision of this standard or for additional standards and should be addressed to ASTM International Headquarters. Your comments will receive careful consideration at a meeting of the responsible technical committee, which you may attend. If you feel that your comments have not received a fair hearing you should make your views known to the ASTM Committee on Standards, at the address shown below.

This standard is copyrighted by ASTM International, 100 Barr Harbor Drive, PO Box C700, West Conshohocken, PA 19428-2959, United States. Individual reprints (single or multiple copies) of this standard may be obtained by contacting ASTM at the above address or at 610-832-9585 (phone), 610-832-9555 (fax), or service@astm.org (e-mail); or through the ASTM website (www.astm.org).