

# Standard Test Method for Flash Point by Continuously Closed Cup (CCCFP) Tester<sup>1</sup>

This standard is issued under the fixed designation D 6450; the number immediately following the designation indicates the year of original adoption or, in the case of revision, the year of last revision. A number in parentheses indicates the year of last reapproval. A superscript epsilon ( $\epsilon$ ) indicates an editorial change since the last revision or reapproval.

## 1. Scope

1.1 This flash point test method is a dynamic method and depends on definite rates of temperature increase. It is one of the many flash point test methods available, and every flash point test method, including this one, is an empirical method.

NOTE 1—Flash point values are not a constant physical-chemical property of materials tested. They are a function of the apparatus design, the condition of the apparatus used, and the operational procedure carried out. Flash point can therefore only be defined in terms of a standard test method, and no general valid correlation can be guaranteed between results obtained by different test methods or with test apparatus different from that specified.

1.2 This test method covers the determination of the flash point of fuel oils, lube oils, solvents, and other liquids by a continuously closed cup tester. The measurement is made on a test specimen of 1 mL.

1.3 This test method utilizes a closed but unsealed cup with air injected into the test chamber.

1.4 This test method is suitable for testing samples with a flash point from 10 to 250°C.

NOTE 2—Flash point determinations below 10°C and above 250°C can be performed; however, the precision has not been determined below and above these temperatures.

1.5 If the user's specification requires a defined flash point method other than this test method, neither this test method nor any other method should be substituted for the prescribed method without obtaining comparative data and an agreement from the specifier.

1.6 The values stated in SI units are to be regarded as standard. Temperatures are in degrees Celsius, pressure in kilo-pascals. The values in parentheses are for information only.

1.7 *This standard does not purport to address all of the safety concerns, if any, associated with its use. It is the responsibility of the user of this standard to establish appropriate safety and health practices and determine the applicability of regulatory limitations prior to use.* For specific hazard statements, see Note 6.

<sup>1</sup> This test method is under the jurisdiction of ASTM Committee D-2 on Petroleum Products and Lubricants and is the direct responsibility of Subcommittee D02.08 on Volatility.

Current edition approved Aug. 10, 1999. Published October 1999.

## 2. Referenced Documents

### 2.1 ASTM Standards:

D 4057 Practice for Manual Sampling for Petroleum and Petroleum Products<sup>2</sup>

D 4177 Practice for Automatic Sampling of Petroleum and Petroleum Products<sup>2</sup>

E 300 Practice for Sampling Industrial Chemicals<sup>3</sup>

### 2.2 ISO Standards:<sup>4</sup>

ISO Guide 34 Quality Systems Guidelines for the Production of Reference Materials

ISO Guide 35 Certifications of Reference Material – General and Statistical Principles

## 3. Terminology

### 3.1 Definitions:

3.1.1 *flash point, n*—the lowest temperature corrected to a pressure of 101.3 kPa at which application of an ignition source causes the vapors of a specimen of the sample to ignite momentarily under specified conditions of the test.

3.1.1.1 *Discussion*—For the purpose of this test method, the test specimen is deemed to have flashed when the hot flame of the ignited vapor causes an instantaneous pressure increase of at least 20 kPa inside the closed measuring chamber.<sup>5</sup>

### 3.2 Definitions of Terms Specific to This Standard:

3.2.1 *dynamic, adj*—the condition in which the vapor above the test specimen and the test specimen are not in temperature equilibrium at the time at which the ignition source is applied.

## 4. Summary of Test Method

4.1 The lid of the test chamber is regulated to a temperature at least 18°C below the expected flash point. A  $1 \pm 0.1$  mL test specimen of a sample is introduced into the sample cup, ensuring that both specimen and cup are at a temperature at least 18°C below the expected flash point, cooling if necessary. The cup is then raised and pressed onto the lid of specified dimensions to form the continuously closed but unsealed test chamber with an overall volume of  $4.0 \pm 0.2$  mL.

<sup>2</sup> *Annual Book of ASTM Standards*, Vol 05.02.

<sup>3</sup> *Annual Book of ASTM Standards*, Vol 15.05.

<sup>4</sup> Available from American National Standards Institute, 11 W 42<sup>nd</sup> Street, 13<sup>th</sup> Floor, New York, NY 10017.

<sup>5</sup> The method of detecting the flash point by monitoring the instantaneous pressure increase is covered by a patent. Interested parties are invited to submit information regarding the identification of an alternative(s) to this patented item to ASTM Headquarters. Your comments will receive careful consideration at a meeting of the responsible technical committee, which you may attend.

4.2 After closing the test chamber, the temperatures of the test specimen and the regulated lid are allowed to equilibrate to within 1°C. Then the lid is heated at a prescribed, constant rate. For the flash tests, an arc of defined energy is discharged inside the test chamber at regular intervals. After each ignition,  $1.5 \pm 0.5$  mL of air is introduced into the test chamber to provide the necessary oxygen for the next flash test. The pressure inside the continuously closed but unsealed test chamber remains at ambient barometric pressure, except for the short time during the air introduction and except at a flash point.

4.3 After each arc, the instantaneous pressure increase above the ambient barometric pressure inside the test chamber is monitored. When the pressure increase exceeds a defined threshold, the temperature at that point is recorded as the uncorrected flash point.

## 5. Significance and Use

5.1 The flash point temperature is one measure of the tendency of the test specimen to form a flammable mixture with air under controlled laboratory conditions. It is only one of a number of properties that must be considered in assessing the overall flammability hazard of a material.

5.2 Flash point is used in shipping and safety regulations to define *flammable* and *combustible* materials and classify them. Consult the particular regulation involved for precise definitions of these classifications.

5.3 This test method can be used to measure and describe the properties of materials in response to heat and an ignition source under controlled laboratory conditions and shall not be used to describe or appraise the fire hazard or fire risk of materials under actual fire conditions. However, results of this test method may be used as elements of a fire risk assessment, which takes into account all of the factors that are pertinent to an assessment of the fire hazard of a particular end use.

5.4 Flash point can also indicate the possible presence of highly volatile and flammable materials in a relatively non-volatile or nonflammable material, such as the contamination of lubricating oils by small amounts of diesel fuel or gasoline.

## 6. Apparatus

6.1 *Flash Point Apparatus, Continuously Closed Cup Operation*—The type of apparatus suitable for use in this test method employs a lid of solid brass, the temperature of which is controlled electrically. Two temperature sensors for the specimen and the lid temperatures, two electrically insulated pins for a high voltage arc, and a connecting tube for the pressure monitoring and the air introduction are incorporated in the lid. Associated equipment for electrically controlling the chamber temperature is used, and a digital readout of the specimen temperature is provided. The apparatus and its critical elements are shown in Figs. A1.1 and A1.2.<sup>6</sup>

6.1.1 *Test Chamber*—The test chamber is formed by the sample cup and the temperature controlled lid and shall have an overall volume of  $4 \pm 0.2$  mL. A metal to metal contact between the lid and the sample cup ensures good heat contact

but shall not be a tight seal to ensure ambient barometric pressure inside the test chamber during the test. Critical dimensions are shown in Fig. A1.2. The pressure inside the measuring chamber during the temperature increase is monitored. A seal that is too tight results in a pressure increase above ambient due to the temperature and the vapor pressure of the sample. A poor heat contact results in a bigger temperature difference between the sample and the heated lid.

6.1.2 *Sample Cup*—The sample cup shall be made of nickel-plated aluminum or other material with similar heat conductivity. It shall have an overall volume of 4 mL and shall be capable of containing  $1 \pm 0.1$  mL of sample. The critical dimensions and requirements are shown in Fig. A1.2.

6.1.3 *Specimen Temperature Sensor*—The specimen temperature sensor (Fig. A1.1: Ts) shall be a thermocouple (NiCr-Ni or similar) in stainless steel of 1-mm diameter with a response time of  $t(90) = 3$  s. It shall be immersed to a depth of at least 2 mm into the specimen. It shall have a resolution of 0.1°C and a minimum accuracy of  $\pm 0.2$ °C, preferably with a digital readout.

6.1.4 *Magnetic Stirring*—The apparatus shall have provisions for stirring the sample. A rotating magnet outside the sample cup shall drive a small stirring magnet, which is inserted into the sample cup after sample introduction. The stirring magnet shall have a diameter of  $3 \pm 0.2$  mm and a length of  $12 \pm 1$  mm. The rotation speed of the driving magnet shall be between 250 and 270 rev/min.

6.1.5 *Air Introduction*—The apparatus shall have provisions for introduction of  $1.5 \pm 0.5$  mL of air immediately after each flash test. The air shall be introduced by a short air pulse from a small membrane compressor by means of a T-inlet in the connecting tube to the pressure transducer.

6.1.6 Electrical heating and thermoelectric cooling of the lid (Fig. A1.1: PE) shall be used to regulate the temperature of the test chamber for the duration of the test. The temperature regulation shall have a minimum accuracy of  $\pm 0.2$ °C.

6.1.7 A high voltage electric arc shall be used for the ignition of the flammable vapor. The energy of the arc shall be  $3 \pm 0.5$  mJ ( $3 \pm 0.5$  Ws) per arc, and the energy shall be applied within  $43 \pm 3$  ms.

NOTE 3—**Caution:** Because samples containing low flash material or having a flash point below the preset initial temperature can oversaturate the vapor inside the chamber and hence prohibit the detection of a flash point in the chosen range, the design of the apparatus should incorporate step-wise ignitions in steps of 10°C, following the closing of the measuring chamber and before the sample reaches the initial temperature of the test.

6.1.8 The pressure transducer for the flash point detection shall be connected to the connecting tube in the lid and shall have a minimum operational range from 80 to 177 kPa with a minimum resolution of 0.1 kPa and a minimum accuracy of  $\pm 0.5$  kPa. It shall be capable of detecting an instantaneous pressure increase above barometric pressure of a minimum of 20 kPa within 100 ms.

NOTE 4—The monitoring of the instantaneous pressure increase above barometric pressure is one of several methods used to determine a flash inside the test chamber. A pressure increase of 20 kPa corresponds to a flame volume of approximately 1.5 mL.

NOTE 5—An automatic barometric correction, which is performed in

<sup>6</sup> Continuously closed cup testers meeting these requirements are available from Grabner Instruments, A-1220 Vienna, Dr. Otto Neurathgasse 1, Austria.

accordance with the procedure described in 12.1, can be installed in the tester. The absolute pressure reading of the pressure transducer described in 6.1.8 may be used for the correction.

6.1.9 The introduction of a test portion of  $1.0 \pm 0.1$  mL shall be accomplished by the use of a pipette or syringe of the required accuracy.

## 7. Reagents and Materials

7.1 *Purity of Reagents*—Use only chemicals of purity requested in Table X1.1. Unless otherwise indicated, it is intended that all reagents conform to the specifications of the Committee on Analytical Reagents of the American Chemical Society where such specifications are available.<sup>7</sup> Other grades may be used, provided it is first ascertained that the reagent is of sufficient purity to permit its use without lessening the accuracy of the determination.

7.1.1 *Anisole*—**Warning**—See Note 6.

7.1.2 *Dodecane*—**Warning**—See Note 6.

7.2 *Cleaning Solvents*—Use only noncorrosive solvents capable of cleaning the sample cup and the lid. Two commonly used solvents are toluene and acetone.

NOTE 6—**Warning**: Anisole, dodecane, toluene, acetone, and many solvents are flammable and are health hazards. Dispose of solvents and waste material in accordance with local regulations.

## 8. Sampling

8.1 Obtain at least a 50 mL sample from a bulk test site in accordance and instruction given in Practice D 4057, D 4177, or E 300. Store the sample in a clean, tightly sealed container at a low temperature.

8.2 Do not store samples for an extended period of time in gas permeable containers, such as plastic, because volatile material may diffuse through the walls of the container. Discard samples in leaky containers and obtain new samples.

8.3 Erroneously high flash points can be obtained when precautions are not taken to avoid loss of volatile material. Do not open containers unnecessarily. Do not make a transfer unless the sample temperature is at least 18°C below the expected flash point. When possible, perform the flash point as the first test.

8.4 Samples of very viscous materials may be warmed until they are reasonably fluid before they are tested. However, do not heat the unsealed sample above a temperature of 18°C below its expected flash point.

8.5 Samples containing dissolved or free water may be dehydrated with calcium chloride or by filtering through a qualitative filter paper or a loose plug of dry absorbent cotton. Warming the sample is permitted, but do not heat the sample above a temperature of 18°C below its expected flash point.

NOTE 7—**Caution**: If the sample is suspected of containing volatile components, the treatment described in 8.4 and 8.5 should be omitted.

<sup>7</sup> *Reagent Chemicals, American Chemical Society Specifications*, American Chemical Society, Washington, D.C. For suggestions on the testing of reagents not listed by the American Chemical Society, see *Analar Standards for Laboratory Chemicals*, BDH Ltd., Poole, Dorset, U.K., and the *United States Pharmacopeia and National Formulary*, U.S. Pharmacopeial Convention, Inc. (USPC), Rockville, MD.

## 9. Quality Control Checks

9.1 Verify the performance of the instrument at least once per year by determining the flash point of a certified reference material (CRM) such as those listed in Appendix X1, which is reasonably close to the expected temperature range of the samples to be tested. The material shall be tested in accordance with Section 11 of this test method, and the observed flash point obtained in 11.11 shall be corrected for barometric pressure as described in Section 12. The flash point shall be within the limits stated in Table X1.1.

9.2 Once the performance of the instrument has been verified, the flash point of secondary working standards (SWSs) can be determined along with their control limits. These secondary materials can then be utilized for more frequent performance checks. (see Appendix X1). A performance check with a SWS shall be performed every day the instrument is in use.

9.3 When the flash point obtained is not within the limits stated in 9.1 or 9.2, follow the manufacturer's instruction for cleaning and maintenance and check the instrument calibration (see Section 10). After any adjustment, repeat the test in 9.1 or 9.2, using a fresh test specimen, with special attention to the procedural details prescribed in this test method.

NOTE 8—**Caution**: The use of single component verification materials, such as those listed in Table X1.1, will only prove the calibration of the equipment. It will not check the accuracy of the entire test method, including sample handling, because losses due to evaporation will not affect the flash point as happens with losses of light ends in multicomponent mixtures.

## 10. Calibration

### 10.1 *Pressure Transducer*:

10.1.1 Check the calibration of the pressure transducer when needed as indicated from the quality control checks performed in accordance with Section 9. The calibration of the transducer is checked, using the ambient barometric pressure as a reference.

10.1.2 If the displayed atmospheric pressure is not equal to the ambient barometric pressure, adjust the transducer control until the appropriate reading is observed. The ambient barometric pressure is the actual station pressure at the location of the tester at the time of measurement.

NOTE 9—**Caution**: Many aneroid barometers, such as those used at weather stations and airports, are precorrected to give sea level readings: These shall not be used for calibration of the apparatus.

10.2 *Temperature Sensor*—Check the calibration of the temperature sensor used to monitor the temperature of the sample when needed as indicated from the quality control checks (see Section 9). Use only reference thermometers that are traceable to the National Institute of Standards and Technology (NIST) or national authorities in the country in which the equipment is used.

## 11. Procedure

11.1 Thoroughly clean and dry the lid together with the arc pins and the sample cup before starting the test, being sure to remove any solvent used to clean the apparatus. If the expected flash point of a sample is more than 15°C higher than the flash point of the previous sample, heat the lid together with an

empty, dry sample cup to a temperature 30°C higher than the expected flash point of the new sample.

NOTE 10—The dry cup heating procedure will eliminate possible cross contamination from residual vapors.

11.2 *Expected Flash Point*—Set the initial temperature to at least 18°C below the expected flash point. Set the final temperature to a value beyond the expected flash point.

11.2.1 *No Expected Flash Point Available*—When testing materials for which no expected flash point temperature is known, set the initial temperature to 10°C and measure the material to be tested in the manner described. This flash point result shall be considered as approximate. The derived value can be used as the expected flash point when a fresh specimen is tested in the standard mode of operation.

11.3 Set the heating rate to  $5.5 \pm 0.5^\circ\text{C}/\text{min}$ .

11.4 Set the ignition frequency to 1°C.

11.5 Set the air introduction to 1.5 mL.

11.6 Set the pressure threshold for the flash detection to 20 kPa.

11.7 Initiate the test procedure to regulate the lid to the initial temperature. When the initial temperature is reached as indicated by the instrument, prepare to introduce the  $1 \pm 0.1$  mL specimen of the sample.

11.8 Ensure that the sealed sample and the sample cup are at least 18°C below the expected flash point temperature, cool if necessary. Shake the sample thoroughly before opening the sample container. Extract 1 mL of sample with a pipette or syringe, and close the container. Transfer  $1 \pm 0.1$  mL of the sample to be tested into the sample cup.

11.9 Insert a stirring magnet into the sample cup to ensure a consistent sample mix.

11.10 Put the sample cup onto the sample cup support of the tester, and start the procedure. Raise and press the sample cup onto the lid, which is at the initial temperature and thus at a higher temperature than the sample cup. While the temperature of the sample cup and the lid are equalizing, apply a precautionary arc at 10°C intervals (see Note 3). If a flash is detected at one of these precautionary arcs, discontinue the test, and discard the result. Repeat the test with a fresh specimen and with a lower initial temperature of at least 18°C below the temperature at which the flash was detected.

11.11 After the temperature between the temperature regulated lid and the specimen have equalized to within 1°C, start the actual test for the flash point. Heat the lid with the programmed heating rate, and apply the arc ignition in equidistant temperature steps of 1°C. Monitor the instantaneous pressure increase within 100 ms after the arc. Stop the test when a flash is detected or when the final temperature is reached in the case of no flash point. The flash point temperature is the specimen temperature at which the instantaneous pressure increase, due to the presence of the flash, exceeds 20 kPa.

11.12 When a flash is detected at a temperature that is higher than 26°C above the initial temperature, or when a flash is detected at a temperature that is less than 10°C above the initial temperature, consider the result approximate and repeat the test with a fresh test specimen. Adjust the expected flash point for this next test to the temperature of the approximate

result. The initial temperature for this fresh test specimen shall be 18°C below the temperature of the previous approximate result.

11.13 Record the specimen temperature reading at the detected flash point as the uncorrected flash point temperature. If no flash point was detected within the tested temperature range, record *flash point is higher than the final temperature*.

11.14 At the conclusion of the test, cool the sample cup below 50°C to withdraw it safely.

## 12. Calculation

12.1 *Barometric Pressure Correction*—Observe and record the ambient barometric pressure at the time of the test. When the pressure differs from 101.3 kPa, correct the flash point as follows:

$$\text{Corrected flash point} = C + 0.25 (101.3 - p) \quad (1)$$

where:

$C$  = observed flash point in °C, and

$p$  = ambient barometric pressure in kPa.

Round the corrected value to the nearest 0.5°C.

NOTE 11—**Caution:** The barometric pressure used in this calculation must be the absolute ambient pressure for the laboratory at the time of the test. Many aneroid barometers, such as those used at weather stations and airports, are corrected to give sea level readings: These shall not be used.

## 13. Report

13.1 Report the corrected flash point as the Test Method D 6450, CCCFP of the test specimen.

## 14. Precision and Bias

14.1 The precision data were developed in a 1996 cooperative test program involving ten laboratories and using three pure chemicals, one pure hydrocarbon, three fuels, and three lubricating oils. The precision statements for both repeatability and reproducibility are for flash points between 10 and 250°C and do not include the No. 6 fuel oil data.<sup>8</sup>

NOTE 12—The precision derived in the cooperative test program for No. 6 fuel oil was significantly worse than for the other samples. It has to be assumed that the procedure described in Section 11 is not applicable for this kind of sample.

14.2 *Precision*—The precision of the procedure for CCCFP, as determined by the statistical examination of the interlaboratory test results, is as follows:

14.2.1 *Repeatability*—The difference between successive results obtained by the same operator with the same apparatus under constant operating conditions on identical test materials would, in the long run, in the normal and correct operation of the test method, exceed the following values in only one case in twenty.

$$\text{Repeatability} \quad r = 1.9^\circ\text{C}$$

14.2.2 *Reproducibility*—The difference between two single and independent results obtained by different operators working in different laboratories on identical material would, in the long run, in the normal and correct operation of the test

<sup>8</sup> Supporting data have been filed at ASTM Headquarters. Request RR:D02-1464.

method, exceed the following values in only one case in twenty.

Reproducibility  $R = 3.1^{\circ}\text{C}$

14.2.3 *Bias*—Since there is no accepted reference material suitable for determining the bias for the procedure in this test method, bias has not been determined.

15. Keywords

15.1 continuously closed cup; flammability; flash point

ANNEX

(Mandatory Information)

A1. APPARATUS SPECIFICATIONS

A1.1 See Fig. A1.1 for CCCFP chamber assembly.

A1.2 See Fig. A1.2 for lid/cup chamber assembly.

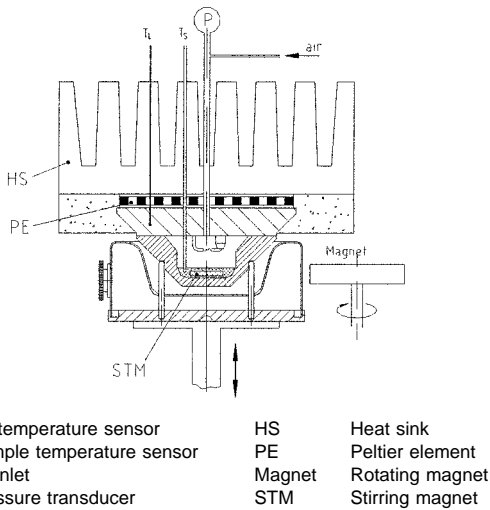

- |     |                           |        |                 |
|-----|---------------------------|--------|-----------------|
| TL  | Lid temperature sensor    | HS     | Heat sink       |
| TS  | Sample temperature sensor | PE     | Peltier element |
| Air | Air inlet                 | Magnet | Rotating magnet |
| P   | Pressure transducer       | STM    | Stirring magnet |

FIG. A1.1 CCCFP Chamber Assembly

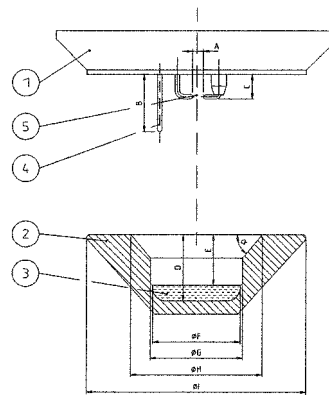

- 1 Lid with incorporated temperature sensor and electric heating, made of brass.
- 2 Sample cup, made of nickel-plated aluminum.
- 3 1 mL specimen.
- 4 Specimen temperature sensor (NiCr-Ni thermocouple).
- 5 Arc pins, made of stainless steel. Arc gap of defined length.

Designation	mm
A	$2.5 \pm 0.2$
B	$14 \pm 0.3$
C	$5.5 \pm 0.2$
D	$15 \pm 0.5$
E	11.5
F	20
G	21
H	30
I	50
$\alpha$	$45^{\circ}$

NOTE 1—Finish of the metal to metal contact surfaces of lid and sample cup: 30 microns.

FIG. A1.2 Lid/Cup Chamber Assembly



**APPENDIX**
**(Nonmandatory Information)**
**X1. APPARATUS VERIFICATION FLUIDS**

X1.1 *Certified Reference Material (CRM)*—A stable hydrocarbon or other stable petroleum product with a method-specific flash point established by a method-specific interlaboratory study following RR:D02-1007<sup>9</sup> guidelines or ISO Guides 34 and 35.

X1.1.1 Typical values of the flash point corrected for barometric pressure for some reference materials and their typical limits are given in Table X1.1 (see Note X1.1). Suppliers of CRMs (see Note X1.3) will provide certificates stating the method-specific flash point for each material of the current production batch. Calculation of the limits for these other CRMs can be determined from the reproducibility value of this test method, reduced by interlaboratory effect and then multiplied by 0.7 (see Research Report RR:S15-1008).<sup>9</sup>

NOTE X1.1—Purities, flash point values, and limits stated for anisole and dodecane were developed in an ASTM interlaboratory program to determine suitability of use for performance fluids in flash point test

methods. Other materials, purities, flash point values, and limits can be suitable when produced in accordance with the practices of RR:D02-1007 guidelines or ISO Guides 34 and 35. Certificates of performance of such materials should be consulted before use.

NOTE X1.2—**Caution:** Handle anisole and dodecane with EXTREME CARE against contamination. Read the manufacturer's material safety data sheet before using.

NOTE X1.3—True CRMs can only be developed once an agreed upon standard test method exists. As this is the first official version of this test method, certified CRMs cannot exist. The data shown in Table X1.1 pertain to the batch of anisole (purity, mole % 99.7+) and dodecane (purity, mole % 99.5+) utilized in the precision study. In the absence of certified CRMs, anisole and dodecane of equivalent purity may be regarded as an acceptable substitute as long as this condition exists. Once CRMs are available, other materials, purities, flash point values, and limits can be suitable when produced in accordance with the practices of RR:D02-1007 guidelines or ISO Guides 34 and 35. Certificates of performance of such materials should be consulted before use, as the flash point value will vary, depending upon the composition of each CRM batch.

X1.2 *Secondary Working Standard (SWS)*—A stable hydrocarbon or other petroleum product whose composition is known to remain appreciably stable.

X1.2.1 Establish the mean flash point and the statistical control limits ( $3\sigma$ ) for the SWS, using standard statistical techniques (see ASTM MNL 7<sup>10</sup>).

<sup>10</sup> *Manual on Presentation of Data Control Chart Analysis*, 6th Ed. Available from ASTM Headquarters.

<sup>9</sup> Available from ASTM Headquarters.

**TABLE X1.1 CCCFP Typical Flash Point Values and Typical Limits for CRM**

Material	Purity (Mole %)	Flash Point (°C)	Limits (°C)
Anisole	99.7+	43.9	± 1.5
Dodecane	99.5+	79	± 2.1

*The American Society for Testing and Materials takes no position respecting the validity of any patent rights asserted in connection with any item mentioned in this standard. Users of this standard are expressly advised that determination of the validity of any such patent rights, and the risk of infringement of such rights, are entirely their own responsibility.*

*This standard is subject to revision at any time by the responsible technical committee and must be reviewed every five years and if not revised, either reapproved or withdrawn. Your comments are invited either for revision of this standard or for additional standards and should be addressed to ASTM Headquarters. Your comments will receive careful consideration at a meeting of the responsible technical committee, which you may attend. If you feel that your comments have not received a fair hearing you should make your views known to the ASTM Committee on Standards, 100 Barr Harbor Drive, West Conshohocken, PA 19428.*

*This standard is copyrighted by ASTM, 100 Barr Harbor Drive, West Conshohocken, PA 19428-2959, United States. Individual reprints (single or multiple copies) of this standard may be obtained by contacting ASTM at the above address or at 610-832-9585 (phone), 610-832-9555 (fax), or service@astm.org (e-mail); or through the ASTM website (<http://www.astm.org>).*