



Standard Test Method for Shear Stability of Polymer Containing Fluids Using a European Diesel Injector Apparatus¹

This standard is issued under the fixed designation D 6278; the number immediately following the designation indicates the year of original adoption or, in the case of revision, the year of last revision. A number in parentheses indicates the year of last reapproval. A superscript epsilon (ϵ) indicates an editorial change since the last revision or reapproval.

1. Scope

1.1 This test method covers the evaluation of the shear stability of polymer-containing fluids. The test method measures the percent viscosity loss at 100°C of polymer-containing fluids when evaluated by a diesel injector apparatus procedure that uses European diesel injector test equipment. The viscosity loss reflects polymer degradation due to shear at the nozzle.

NOTE 1—Test Method D 2603 has been used for similar evaluation of shear stability; limitations are as indicated in the significance statement. No detailed attempt has been undertaken to correlate the results of this test method with those of the sonic shear test method.

NOTE 2—This test method uses test apparatus as defined in CEC L-14-A-93. This test method differs from CEC-L-14-A-93 in the period of time required for calibration.

NOTE 3—Test Method D 5275 also shears oils in a diesel injector apparatus but may give different results.

NOTE 4—This test method has different calibration and operational requirements than Test Method D 3945.

1.2 *This standard does not purport to address all of the safety concerns, if any, associated with its use. It is the responsibility of the user of this standard to establish appropriate safety and health practices and determine the applicability of regulatory limitations prior to use. Specific precautionary statements are given in Section 8.*

2. Referenced Documents

2.1 ASTM Standards:

D 445 Test Method for Kinematic Viscosity of Transparent and Opaque Liquids (and the Calculation of Dynamic Viscosity)²

D 2603 Test Method for Sonic Shear Stability of Polymer-Containing Oils³

D 3945 Test Method for Shear Stability of Polymer-Containing Fluids Using a Diesel Injector Nozzle³

D 5275 Test Method for Fuel Injector Shear Stability Test

¹ This test method is under the jurisdiction of ASTM Committee D02 on Petroleum Products and Lubricants and is the direct responsibility of Subcommittee D02.07 on Flow Properties.

Current edition approved April 10, 2002. Published June 2002. Originally published as D 6278–98. Last previous edition D 6278–98.

² *Annual Book of ASTM Standards*, Vol 05.01.

³ *Annual Book of ASTM Standards*, Vol 05.02.

(FISST) for Polymer Containing Fluids⁴

D 6299 Practice for Applying Statistical Quality Assurance Techniques to Evaluate Analytical Measurement System Performance⁵

2.2 *Coordination European Council (CEC) Standard:*
CEC L-14-A-93 Evaluation of the Mechanical Shear Stability of Lubricating Oils Containing Polymers⁶

3. Terminology

3.1 Definitions:

3.1.1 *kinematic viscosity, n*—a measure of the resistance to flow of a fluid under gravity.

3.2 Definitions of Terms Specific to This Standard:

3.2.1 *calibration pressure, n*—the recorded gage pressure when calibration fluid RL 34 undergoes a viscosity loss of 2.75 to 2.85 mm²/s when the recorded gage pressure is within the range of 13.0 to 18.0 MPa.

3.2.2 *viscosity loss, n*—the loss in viscosity determined from the difference in kinematic viscosity at 100°C of pre-sheared and post-sheared fluid.

3.2.3 *percent viscosity loss, n*—viscosity loss, as defined in 3.2.2, divided by the pre-sheared viscosity, and reported as a percent.

4. Summary of Test Method

4.1 A polymer-containing fluid is passed through a diesel injector nozzle at a shear rate that causes polymer molecules to degrade. The resultant degradation reduces the kinematic viscosity of the fluid under test. The percent viscosity loss is a measure of the mechanical shear stability of the polymer-containing fluid.

5. Significance and Use

5.1 This test method evaluates the percent viscosity loss for polymer-containing fluids resulting from polymer degradation in the high shear nozzle device. Thermal or oxidative effects are minimized.

5.2 This test method is used for quality control purposes by

⁴ *Annual Book of ASTM Standards*, Vol 05.03.

⁵ *Annual Book of ASTM Standards*, Vol 05.04.

⁶ Available from CEC Secretariat, Madou Plaza, 25th floor, Place Madou 1, B-1210 Brussels, Belgium.

manufacturers of polymeric lubricant additives and their customers.

5.3 This test method is not intended to predict viscosity loss in field service in different field equipment under widely varying operating conditions, which may cause lubricant viscosity to change due to thermal and oxidative changes as well as by the mechanical shearing of polymer. However, when the field service conditions, primarily or exclusively, result in the degradation of polymer by mechanical shearing, there may be a correlation between the results from this test method and results from the field.

6. Apparatus

6.1 The apparatus consists of a fluid reservoir, a double-plunger pump with an electric motor drive, an atomization chamber with a diesel injector spray nozzle, and a fluid cooling vessel, installed in an area with an ambient temperature of 20 to 25°C (68 to 77°F). Figure A1.1 shows the schematic representation of equipment.

6.1.1 *Fluid Reservoir*, In Fig. A1.1, (7)⁷ is open on the top, has approximately a 250 mL capacity, has a 45-mm (1.772-in.) inner diameter, and is calibrated in units of volume. It is fitted with an internal fluid distributor as detailed in Fig. A1.2. A 40-mm (1.575-in.) diameter watch glass with serrated edges is an acceptable distributor plate. The distributor reduces the tendency of fluid channeling. Temperature is measured by a thermometer suspended in the center of the fluid reservoir. The bottom of the thermometer bulb shall be 10 to 15 mm above the entrance to the drain tube opening. Other temperature-measuring equipment positioned at the same location may also be used. The outlet is equipped with a three-way stopcock (8). The three-way stopcock is of a cone type with a nonexchangeable solid plug with an 8-mm (0.315-in.) nominal bore size. Transparent, plastic tubing, (10) in Fig. A1.1, is used to connect the three-way stopcock to the pump inlet.

6.1.2 *Double-Plunger Injection Pump*, In Fig. A1.1 (11) is defined as Bosch PE 2 A 90D 300/3 S2266. This pump is equipped with a stroke counter, (15), venting screw, (14), and flow rate adjusting screw, (12).

6.1.3 *Injection Pump*, driven by a three-phase electric motor, (13) in Fig. A1.1., rated at a speed of 925 ± 25 rpm.

6.1.3.1 This motor runs at 925 rpm on the 50 Hz current prevalent in Europe; it will run at approximately 1100 rpm on 60 Hz current. The 1100 rpm speed is not acceptable in this procedure. A suitable means shall be taken to ensure the prescribed 925 ± 25 rpm speed to the injection pump. One acceptable method is to use a 6 to 5 speed reducer.

6.1.4 *Outlet of Injection Pump*, connected to the atomization chamber using high pressure steel tubing. The atomization chamber, (2) in Fig. A1.1, is defined in more detail in Fig. A1.3. To minimize foam generation, the spray chamber is designed so that the fluid under test exits from the nozzle into a chamber filled with the test fluid. A drain tube (17) fitted with a two-way stopcock is included to minimize contamination from the previous test during the system cleaning steps. The diesel injector nozzle is a Bosch DN 8 S 2-type pintle nozzle injector,

number 0434 200 012, installed in a Bosch KD 43 SA 53/15 nozzle holder. The nozzle holder includes a filter cartridge.

NOTE 5—Take great care to avoid damage to the precision parts of the fuel injection equipment (the plunger and barrel in the pump and the nozzle valve assembly). Service work on the equipment should be performed by a diesel fuel injector pump specialist or with reference to the manufacturer's service manual.⁸

NOTE 6—An unusual rapid rise in gage pressure during testing may signify filter blockage. When this occurs, the filter cartridge shall be replaced.

6.1.5 A pressure sensing device (18), such as a glycerol-filled pressure gage or *electronic, digital display pressure indicator*, shall be installed and separated from the line by a pressure snubber or needle valve to suitably dampen pressure surges. The pressure device shall be occasionally pressure tested to ensure accuracy.

6.1.6 *Fluid Cooling Vessel*, ((5) in Fig. A1.1), used to maintain the specified temperature of the test fluid, as indicated at the outlet of the fluid reservoir. This vessel is a glass container with exterior cooling jacket constructed so that the heat transfer surface of the jacket is spherical. The exterior jacket diameter, d_1 , is approximately 50 mm (1.969 in.). The interior heat transfer surface, d_2 , is approximately 25 mm (0.984 in.) in diameter. The overall length, L , is approximately 180 mm (7.087 in.). A distributor plate, similar in design to the distributor plate in the fluid reservoir, is positioned in the upper portion of the fluid cooling vessel to ensure contact between the fluid and the cooling surface. The discharge from the fluid cooling vessel is through a three-way stopcock of the same design used on the discharge of the fluid reservoir. The exterior cooling jacket shall be supplied with an adjustable volume of cold water.

7. Materials

7.1 *Diesel Fuel (No. 2)*, initially required to adjust the diesel injector nozzle valve opening pressure.

7.2 *Calibration Fluid RL 34*, used to ensure that when the apparatus is adjusted within a prescribed pressure range, the correct viscosity loss is obtained.

8. Hazards

8.1 **Warning**—Use a safety shield between the high-pressure components and the operator during use of equipment.

8.2 **Precaution**—During operation, the line between the pump and nozzle, ((16) in Fig. A1.1), is under a pressure of at least 13.0 MPa (130 bar, or 1,885 psi). Pressures above the upper limit of 18.0 MPa (180 bar or 2611 psi) are possible if filter plugging occurs. Shut off the pump prior to tightening any fitting that is not properly sealed.

9. Sampling

9.1 Approximately 600 mL of fluid is needed per test.

9.2 The test fluid shall be at room temperature, uniform in appearance, and free of any visible insoluble material prior to placing in the test equipment.

⁷ The number in parentheses refers to the legend in Fig. A1.1.

⁸ Repair Instructions for Diesel Injection Pumps Size A, B, K and Z, Bulletin WJP 101/1 B EP, Robert Bosch GmbH, 2800 South 25th Ave., Broadview, IL 60153.

9.3 Water and insolubles shall be removed before testing, or filter blocking and nozzle wear may occur. Filter blocking can be detected by a sudden change in gage pressure. The transport of insolubles to the shear zone will shorten nozzle life.

10. Calibration and Standardization

10.1 *Nozzle Adjustments*—If the nozzle to be used is new or has not been pre-calibrated, adjust the diesel injector nozzle holder with the nozzle in place. Adjust the nozzle using diesel fuel and a nozzle tester so that the valve opening pressure is 13.0 MPa (1885 psi) under static conditions. If the nozzle has been pre-calibrated with RL34 calibration oil, adjust the valve opening pressure to the calibration pressure prescribed, which must be between 13.0 MPa and 18.0 MPa (2611 psi).

10.1.1 Install the nozzle and the nozzle holder in the test apparatus. The pintle/spray nozzle shall be tightly fitted in the chamber to avoid leakage of oil around the external surface of the spray nozzle.

10.2 *Measurement of Residual Undrained Volume, V_{res}* :

10.2.1 The residual undrained oil volume of the system is the volume of the system between the three-way stopcock below the fluid reservoir, (8) in Fig. A1.1, and the injector nozzle orifice, (1). V_{res} does not include the atomization chamber volume. When the residual undrained volume is known, go to 10.3.

10.2.2 To determine residual undrained volume, first remove as much fluid as possible by briefly running the pump.

10.2.3 Remove the high-pressure lines, (16) in Fig. A1.1, and drain. Remove the plug at the end of the pump gallery to drain the remaining oil in the pump. Drain atomization chamber (2).

10.2.4 Reassemble the system and close all drains. The upper three-way stopcock (6) shall be open to the lower reservoir (7) and the lower three-way cock (8) shall be open to the pump suction (10).

10.2.5 Add 170 mL of RL34 calibration oil to the lower reservoir (7) and observe the level. Start the pump and run for several minutes until the oil is transparent and free of suspended air.

10.2.6 Stop the pump. Drain the fluid in the atomization chamber into a beaker and then pour the fluid back into the lower reservoir; draining to waste will result in an error in the measurement of V_{res} . Allow the system to drain for 20 min and free air trapped in the transparent connecting tube between the lower reservoir and pump.

10.2.7 Observe the difference in oil level in the lower reservoir compared to that noted in 10.2.5. Record this difference as the residual volume, V_{res} .

NOTE 7—Undrained residual volumes of 15 to 30 mL have been reported by various users of this test. V_{res} measurements in excess of this may occur when fluid in the atomization chamber is not poured back into the lower reservoir as in 10.2.6, or if the length of line (10) is excessive.

10.2.8 Calculate the run volume, V_{run} , which is the subtractive difference between 170 mL and V_{res} .

10.3 *Cleaning the Apparatus, Setting the Stroke Counter, and Adjusting the Pump Stroke*:

10.3.1 Drain residual oil by way of drain line (17) from the atomization chamber into a waste container. Drain fluid in the cooling jacket by means of stopcock (6) (Fig. A1.1) and the

fluid reservoir by means of stopcock (8), into suitable waste containers.

10.3.2 After fluid has drained, leave the stopcock on the drain line to the atomization chamber open and the three-way stopcock (6) positioned so that fluid in the cooling jacket drains to a waste container. Position stopcock (8) so that the drain is closed but the fluid reservoir is open to pump suction through line (10). Add a minimum of 50 mL of RL34 to the fluid reservoir.

NOTE 8—Steps 10.3.2-10.3.7 are representative of the first and second purges with 50 mL fluid that are needed to remove used oil from the apparatus prior to calibration and testing. For these steps, the stopcock below the atomization chamber and cooling jackets are set so that oil will flow into waste containers.

10.3.3 Free the apparatus of air in the line by use of the venting screw, (14), and by manual compression of the transparent flexible tube that connects the pump to the fluid reservoir.

10.3.4 Set the stroke counter so that the pump will run a sufficient length of time to evacuate the fluid out of the fluid reservoir.

10.3.5 Start the pump. Observe the fluid level in the reservoir and stop the pump when all the fluid is out of the base of the reservoir but is still fully-retained in line (10).

10.3.6 Add a minimum of 50 mL of RL34 fluid to the fluid reservoir a second time and operate the pump until the fluid reservoir is empty but line (10) is still filled with fluid.

10.3.7 After all oil has drained, close the stopcock on the atomization chamber drain line (17), position stopcock (6) so that fluid will flow from the cooling jacket into the fluid reservoir.

10.3.8 Remove the thermometer or temperature probe from the fluid reservoir.

NOTE 9—The thermometer and assembly can interfere with the obtainment of accurate volume measurements in the fluid reservoir, hence its removal is called for when the accurate determination of fluid volume is needed. A thermocouple or thermistor probe is a suitable alternative to a thermometer.

10.3.9 Add a minimum amount of fluid equal to the sum of 30 mL plus V_{run} , determined in 10.2.8, to the fluid reservoir.

10.3.10 Close the stopcock below the atomization chamber drain line (17) and position stopcock (6) so that the fluid will drain from the cooling jacket into the fluid reservoir.

NOTE 10—The atomization chamber drain line is always closed for the third cleaning run and all test runs.

10.3.11 Free the apparatus of air in the line by manual compression of the flexible tube (10) that connects the pump to the fluid reservoir. The venting screw, (14), is also used for this purpose.

10.3.12 Record the number on the stroke counter.

10.3.13 Use a stopwatch or other timing device and run the pump for 1 min \pm 1 s.

10.3.14 Determine n , the difference in the stroke count from 10.3.12.

10.3.15 Set the stroke counter shutoff to the product of three times n . The pump shall run for 3 min. Obtain a timing device to observe the time the stroke counter is on to ensure n is correct. Start the pump and allow oil to circulate until the

impulse counter shuts down the instrument.

10.3.16 When all fluid has drained, adjust the volume of oil in the fluid reservoir so that the volume is equal to V_{run} .

10.3.17 Set the impulse counter to 0.5 (n).

10.3.18 Close stopcock (6) so that fluid will be stored in the cooling jacket after the pump is started.

10.3.19 Start the pump. When the pump stops and draining is complete, subtract the volume now in the fluid reservoir from V_{run} .

10.3.20 If the difference is within ± 2.5 mL of 1/2 of V_{run} , proceed to 10.4.

10.3.21 When the volume in the fluid reservoir is not within ± 2.5 mL of V_{run} , drain the fluid from the cooling jacket back into the fluid reservoir, adjust the pump stroke by means of the pump adjustment screw (12), and repeat steps beginning with 10.3.16.

10.4 *Warm-up*—A half-hour warm up period is required before proceeding to calibrate with RL34. Set the stroke counter shut-off to 30 times n strokes, and start the pump.

NOTE 11—This warm up period is only required for the first within-day calibration.

10.5 *Removal of Fluid*—Open the stopcock below the atomization chamber and drain to waste. Drain the fluid from the cooling jacket into a waste container. Position stopcock (8) so that all fluid in the fluid reservoir is removed to a waste container. When drainage is complete, position stopcock (8) so that the drain is closed and the pump inlet line (10) is open.

10.6 *Calibration with RL34:*

10.6.1 Ensure that the ambient (room) temperature is between 20 to 25°C.

10.6.2 Add a minimum of 50 mL of RL34 to the fluid reservoir. Position the three-way stopcock, (6) in Fig. A1.1, below the cooling vessel to discharge fluid into a suitable waste container and leave the stopcock open below the atomization chamber. Operate the pump until the fluid reservoir is empty but line (10) is still filled with fluid.

10.6.3 Free the apparatus of air in the line by manual compression of the flexible tube that connects the pump to the fluid reservoir. When necessary, venting screw (14) is also used for this purpose.

10.6.4 Add a minimum of 50 mL of test fluid to the fluid reservoir a second time and operate the pump until the fluid reservoir is empty again but line (10) is full.

10.6.5 Close the stopcock below the atomization chamber, position the stopcock below the fluid reservoir so that the line to the pump is open, and retain the position of the stopcock below the cooling jacket so that the first 50 mL of RL34 can be drained into a waste container.

10.6.6 Place a volume of RL34 in the fluid reservoir equal to V_{run} plus 30 mL.

10.6.7 Start the pump, and stop the pump when there is a 50 mL drop of fluid in the fluid reservoir. After draining is complete, re-position the stopcock below the cooling jacket so subsequent fluid flows directly into the fluid reservoir.

10.6.8 Set the stroke counter for automatic shutoff at the required number of impulses (30 multiplied by n impulses per minute). The flow rate will be 170 mL/min as set in 10.3.

10.6.9 Adjust, if necessary, the volume of fluid in the fluid reservoir to V_{run} .

10.6.10 Place the temperature measuring device in the fluid reservoir, and start the pump.

10.6.11 After about 10 mins of operation, adjust the water flow to control the fluid temperature at 30 to 35° C, as measured at the discharge point of the fluid reservoir. Approximately 10 mins of operation will be required before the temperature can be stabilized.

10.6.12 At approximately ten cycles of operation, record the gage pressure reading to the nearest 0.1 MPa, when a glycerol-filled pressure gage is being used, or to 0.01 MPa, when an electronic pressure device is employed.

10.6.12.1 The pressure measurement device must occasionally be pressure tested to ensure accuracy.

10.6.13 After 30 cycles has elapsed and the pump has stopped, open the stopcock below the atomization chamber and drain fluid into a waste container. Open the three-way stopcock below the fluid reservoir and discharge the first 10 to 15 mL as waste in order to flush out the drain line. Discharge the remaining fluid into a clean sample container. After the fluid has drained, close the three-way stopcock.

10.6.14 Remove the thermometer or temperature probe.

10.6.15 Using Test Method D 445, determine the kinematic viscosity at 100° C of unsheared (untested) RL 34, as well as the sheared fluid from 10.6.13. Use the same viscometer tube for the measurement of each oil.

10.6.16 Calculate viscosity loss (V_L) as follows:

$$V_L = V_u - V_s \quad (1)$$

where:

V_u = kinematic viscosity of unsheared oil at 100°C, mm²/s, and

V_s = kinematic viscosity of sheared oil at 100°C, mm²/s.

10.6.17 V_L for RL34 shall be within the range of 2.75 to 2.85 mm²/s at 100°C at a gage pressure reading between 13.0 and 18.0 MPa, as recorded after 10 min of test time. When this is achieved, the gage pressure recorded in 10.6.12 will subsequently be referred to as the calibration pressure.

10.6.18 If V_L is less than 2.75 mm²/s, increase the gage pressure. If V_L is greater than 2.85 mm²/s, reduce the gage pressure, provided that the gage pressure recorded in 10.6.12 is greater than 13.0 MPa and less than 18.0 MPa. To alter the pressure, remove the dust cover of the spray nozzle holder (see Fig. A1.4), loosen the locking nut, and turn the adjustment screw that regulates valve opening pressure. Then, tighten the locking nut and replace the dust cover. The nozzle and nozzle holder need not be removed from the apparatus. Continue to retest RL 34 and make adjustments until calibration is achieved.

NOTE 12—It is extremely important that the locking nut be completely tightened. When it is not, some leakage of fluid around the outside of the nozzle assembly may occur. This may result in a reduction of mechanical shearing for some oils, which can adversely influence precision. This condition can be monitored by use of a recorder and an electronic pressure measurement device. Leakage results in a sudden drop in pressure when fluid by-passes the nozzle orifice.

10.6.19 When V_L is greater than 2.85 mm²/s at a gage pressure of only 13.0 MPa, pre-condition the nozzle by

substitution of a fully-formulated engine lubricant as the test fluid. The stroke counter shut-off shall be adjusted so that the test time is at least 8 h, instead of 30 min. Then retest RL34, beginning with 10.5. Continue to pre-condition and evaluate new nozzles until the calibration requirement of 10.6.17 is achieved.

NOTE 13—Suitable *break-in* oils include fully-formulated SAE 15W-40 heavy-duty engine lubricants.

10.6.20 When viscosity decrease is below $2.75 \text{ mm}^2/\text{s}$ at a gage pressure of 18.0 MPa, another nozzle shall be installed and the calibration procedure shall be repeated.

NOTE 14—Before calibration with a new nozzle, it is advisable to subject the nozzle to at least a 4 h run-in with break-in oil.

10.7 Calibration Period:

10.7.1 *Calibration with RL34 Fluid*—Frequent testing of the apparatus with the calibration oil is recommended. The apparatus must be recalibrated after 420 cycles.

10.7.2 *Calibration with RL34 and Monitoring System Stability and Precision with a Quality Control Oil per Practice D 6299*—A quality control oil can be used to monitor calibration once the nozzle has been calibrated with RL34 fluid. This Quality Control fluid shall have a new oil kinematic viscosity at 100°C of between 14.0 – $17.0 \text{ mm}^2/\text{s}$ and after test kinematic viscosity decrease at 100°C of between 2.0 and $3.0 \text{ mm}^2/\text{s}$. The base oil for this fluid shall have a kinematic viscosity of between 4.0 – $8.0 \text{ mm}^2/\text{s}$ at 100°C . The calibration procedure is as follows:

10.7.2.1 Calibrate with RL34.

10.7.2.2 Monitor stability and precision of the system through QC sample testing per Practice D 6299, paragraph 7.1. This will initially require 15 in control samples to develop a control chart.

10.7.2.3 The quality control oil shall be run on the same day that a test fluid is evaluated.

10.7.2.4 Any deviation or trend indicated in the control chart shall call for a recheck with RL34 fluid. A recheck with RL34 must be done after 7 days even if no recheck has been called.

NOTE 15—The reproducibility and repeatability reported in the test method is based on data obtained when the test instruments were calibrated on a daily basis with RL34.

11. Procedure

11.1 *Flow Rate Adjustment for Test Oil*—Open the stopcock on the atomization chamber and drain any previous fluid out of the chamber. Position the three-way stopcock ((6) in Fig. A1.1) below the cooling jacket to discharge fluid into a suitable waste container. Then, position stopcock (8) so that the drain line is closed but line (10) is open from the fluid reservoir to the pump.

11.1.1 Add a minimum of 50 mL of test fluid to the fluid reservoir.

11.1.2 Free the apparatus of air in the line by manual compression of the flexible tube that connects the pump to the fluid reservoir. When necessary, the venting screw, (14), is also used for this purpose.

11.1.3 Operate the pump until the fluid reservoir is empty, but line (10) is full.

11.1.4 Add a minimum of 50 mL of test fluid to the fluid reservoir a second time and operate the pump until the fluid reservoir is empty again but line (10) is still full.

11.1.5 After draining is complete, close the stopcock on the atomization chamber and position stopcock (6) so that fluid will flow from the cooling jacket into the fluid reservoir.

11.1.6 Add an amount of test fluid to the fluid reservoir equal to the sum of 30 mL plus V_{run} .

11.1.7 Free the apparatus of air in the line by use of the venting screw, (14), and by manual compression of the flexible tube that connects the pump to the fluid reservoir.

11.1.8 Set the stroke counter to the product of three times n , and start the pump and allow oil to circulate until the impulse counter shuts down the instrument.

11.1.9 Adjust the oil level in the fluid reservoir to V_{run} by draining any excess oil to a waste container, or adding oil when needed.

11.1.10 Set the impulse counter to the product of 0.5 times n .

11.1.11 Close stopcock (6) so that fluid will be stored in the cooling jacket after the pump is started.

11.1.12 Start the pump. When the pump stops, subtract the volume now in the fluid reservoir, (7), from V_{run} .

11.1.13 When the difference is within $\pm 2.5 \text{ mL}$ of $1/2$ of V_{run} , proceed to 11.2.

11.1.14 If the volume in the fluid reservoir is not within $\pm 2.5 \text{ mL}$ of V_{run} , adjust the pump stroke slightly by means of the pump adjustment screw, (12), drain the fluid from the cooling jacket into the fluid reservoir, and repeat steps beginning with 11.1.6.

11.2 *Removal of Fluid*—Leave stopcock below atomization chamber closed. Drain the fluid from the cooling jacket into a waste container then re-position the stopcock so that the fluid will flow into the fluid reservoir. Then open the three-way stopcock below the fluid reservoir to discharge fluid into a waste container.

11.2.1 *Test Oil Evaluation*—Re-position stopcock (8) so that line (10) is open. Leave the stopcock below the atomization chamber closed. Re-position stopcock (6) below the cooling jacket so that the first 50 mL of test oil is sent to a waste container.

11.2.2 Place a volume of test oil in the fluid reservoir equal to V_{run} plus 30 mL.

11.2.3 Free the apparatus of air in the line by manual compression of the flexible tube that connects the pump to the fluid reservoir. When necessary, the venting screw, (14), is also used for this purpose.

11.2.4 Start the pump, and stop the pump when there is a 50 mL drop of fluid in the fluid reservoir. When draining is complete, re-position the stopcock below the cooling jacket so subsequent fluid flows directly into the fluid reservoir.

11.2.5 Set the stroke counter for automatic shutoff at the required number of impulses (30 multiplied by n impulses per minute).

11.2.6 When necessary, adjust the volume in the fluid reservoir to V_{run} .

11.2.7 Insert the thermometer assembly or temperature probe in the fluid reservoir.

11.2.8 Start the pump.

11.2.9 Within the first 10 mins, adjust the water flow to control the fluid temperature at 30 to 35° C, as measured at the discharge point of the fluid reservoir.

NOTE 16—It is not necessary to record the gage pressure reading here, which may differ from the previously recorded calibration pressure.

11.2.10 After 30 cycles has elapsed and the pump had stopped, open the stopcock below the atomization chamber and drain fluid into a waste container. Open the three-way stopcock below the fluid reservoir and discharge the first 10 to 15 mL as waste in order to flush out the drain line. Discharge the remaining fluid into a clean sample container. Remove the thermometer assembly or probe.

11.2.11 Using Test Method D 445, determine the kinematic viscosity at 100°C of unsheared (untested) RL 34, as well as the sheared fluid from 11.2.10. Use the same viscometer tube for the measurement of each oil.

12. Calculation

12.1 Calculate the percent viscosity loss (PVL) of the sheared oil as follows:

$$PVL = 100 \times (V_u - V_s) / V_u \quad (2)$$

where:

V_u = kinematic viscosity of unsheared oil at 100°C, mm²/s,
and

V_s = kinematic viscosity of sheared oil at 100°C, mm²/s.

13. Report

13.1 Report the following information:

13.1.1 The calibration pressure, in MPa.

13.1.2 Kinematic viscosity of the unsheared oil at 100°C.

13.1.3 Kinematic viscosity of the sheared oil at 100°C.

13.1.4 Percent viscosity loss (PVL) as calculated in 12.1.

14. Precision and Bias

14.1 The precision of this test method as determined by the statistical examination of interlaboratory test results is as follows:⁹

14.1.1 *Repeatability*— The difference between successive test results, obtained by the same operator with the same apparatus under constant operating conditions on identical test material would, in the long run, and in the normal and correct operation of the test method, exceed the following values only in one case in twenty:

1.05 %

14.1.2 *Reproducibility*— The difference between two single and independent results, obtained by different operators working in different laboratories on identical test material would, in the long run, and in the normal and correct operation of the test method, exceed the following values only in one case in twenty:

2.68 %

NOTE 17—The indicated repeatability and reproducibility values for PVL represent the subtractive difference between the reported percent kinematic viscosity loss values for the two determinations being compared.

14.2 *Bias*—All test results are relative to those of the calibration fluid. Therefore, no estimate of bias can be justified.

15. Keywords

15.1 diesel injector apparatus; mechanical shear stability; polymer containing fluid; viscosity loss

⁹ Supporting data are available from ASTM International Headquarters. Request RR:D02-1426.

ANNEX

(Mandatory Information)

A1. EQUIPMENT

A1.1 The equipment is presented in Figs. A1.1-A1.4.

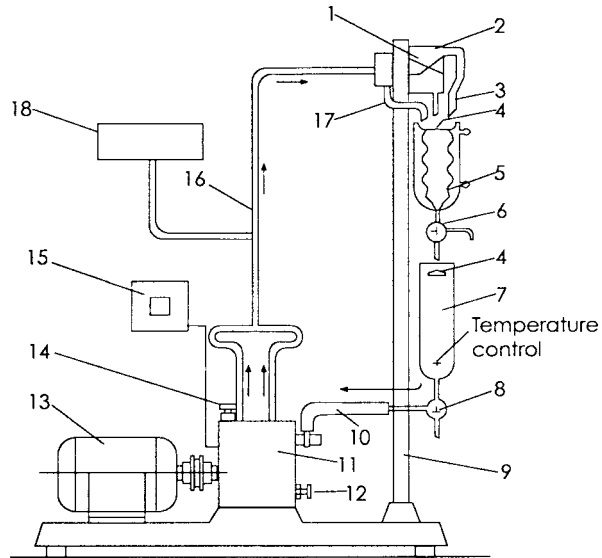

- NOTE 1—Legend
- (1) Spray Nozzle
 - (2) Atomization chamber
 - (3) Outlet of the atomization chamber
 - (4) Distributor plate
 - (5) Glass container fluid reservoir
 - (6) Three-way cock downstream of glass
 - (7) Glass container fluid reservoir
 - (8) Three-way cock downstream of glass container
 - (9) Support column
 - (10) Connection with pump-suction opening
 - (11) Double-plunger injection pump
 - (12) Pump setting screw
 - (13) Electric motor
 - (14) Venting screw/pump
 - (15) Stroke counter
 - (16) Pressure tubing from pump to injector
 - (17) Return line for overflowing liquid
 - (18) Pressure sensing device

FIG. A1.1 Apparatus for Shear Stability Testing

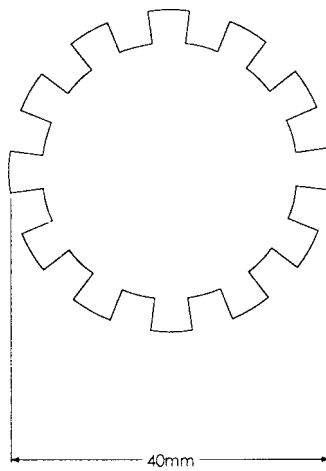

FIG. A1.2 Distributor Plate

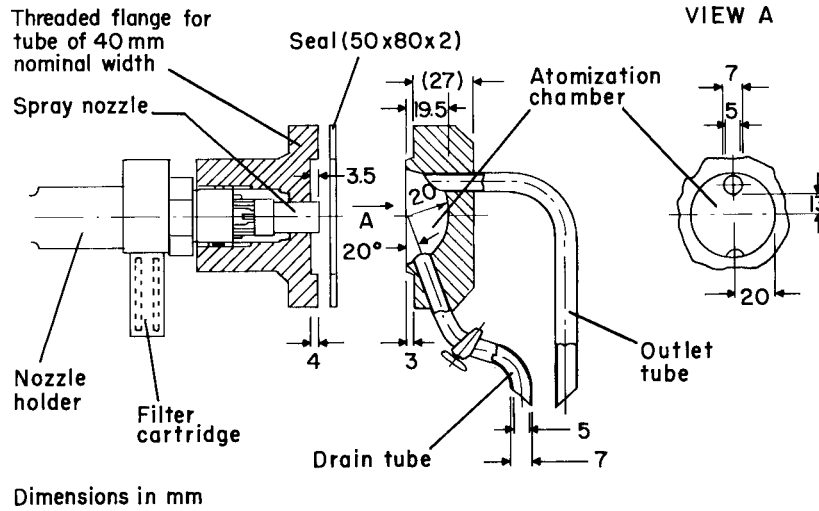

FIG. A1.3 Atomization Chamber with Spray Nozzle and Nozzle Holder

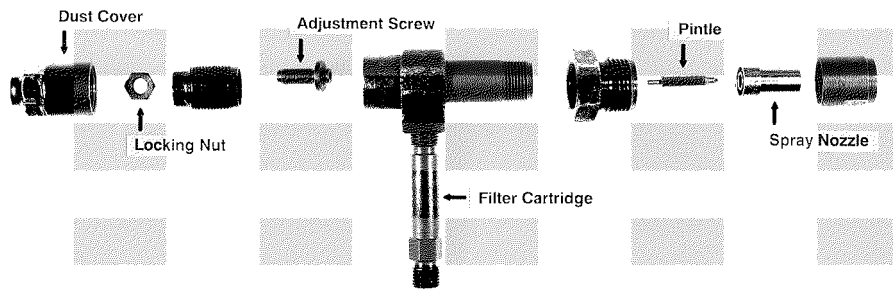

FIG. A1.4 Spray Nozzle and Nozzle Holder

ASTM International takes no position respecting the validity of any patent rights asserted in connection with any item mentioned in this standard. Users of this standard are expressly advised that determination of the validity of any such patent rights, and the risk of infringement of such rights, are entirely their own responsibility.

This standard is subject to revision at any time by the responsible technical committee and must be reviewed every five years and if not revised, either reapproved or withdrawn. Your comments are invited either for revision of this standard or for additional standards and should be addressed to ASTM International Headquarters. Your comments will receive careful consideration at a meeting of the responsible technical committee, which you may attend. If you feel that your comments have not received a fair hearing you should make your views known to the ASTM Committee on Standards, at the address shown below.

This standard is copyrighted by ASTM International, 100 Barr Harbor Drive, PO Box C700, West Conshohocken, PA 19428-2959, United States. Individual reprints (single or multiple copies) of this standard may be obtained by contacting ASTM at the above address or at 610-832-9585 (phone), 610-832-9555 (fax), or service@astm.org (e-mail); or through the ASTM website (www.astm.org).