



# Standard Test Methods for Aniline Point and Mixed Aniline Point of Petroleum Products and Hydrocarbon Solvents<sup>1</sup>

This standard is issued under the fixed designation D 611; the number immediately following the designation indicates the year of original adoption or, in the case of revision, the year of last revision. A number in parentheses indicates the year of last reapproval. A superscript epsilon ( $\epsilon$ ) indicates an editorial change since the last revision or reapproval.

*These test methods were adopted as a joint ASTM-IP standard in 1964.*

*This standard has been approved for use by agencies of the Department of Defense.*

## 1. Scope

1.1 These test methods cover the determination of the aniline point of petroleum products and hydrocarbon solvents. Method A is suitable for transparent samples with an initial boiling point above room temperature and where the aniline point is below the bubble point and above the solidification point of the aniline-sample mixture. Method B, a thin-film method, is suitable for samples too dark for testing by Method A. Methods C and D are for samples that may vaporize appreciably at the aniline point. Method D is particularly suitable where only small quantities of sample are available. Method E describes a procedure using an automatic apparatus suitable for the range covered by Methods A and B.

1.2 These test methods also cover the determination of the mixed aniline point of petroleum products and hydrocarbon solvents having aniline points below the temperature at which aniline will crystallize from the aniline-sample mixture.

1.3 *This standard does not purport to address all of the safety concerns, if any, associated with its use. It is the responsibility of the user of this standard to establish appropriate safety and health practices and determine the applicability of regulatory limitations prior to use.* Specific precautionary statements are given in Section 7.

## 2. Referenced Documents

### 2.1 ASTM Standards:

D 1015 Test Method for Freezing Points of High-Purity Hydrocarbons<sup>2</sup>

D 1217 Test Method for Density and Relative Density (Specific Gravity) of Liquids by Bingham Pycnometer<sup>2</sup>

D 1218 Test Method for Refractive Index and Refractive

Dispersion of Hydrocarbon Liquids<sup>2</sup>

D 1500 Test Method for ASTM Color of Petroleum Products (ASTM Color Scale)<sup>2</sup>

D 2700 Test Method for Motor Octane Number of Spark-Ignition Engine Fuel<sup>3</sup>

E 1 Specification for ASTM Thermometers<sup>4</sup>

## 3. Terminology

### 3.1 Definitions:

3.1.1 *aniline point*—the minimum equilibrium solution temperature for equal volumes of aniline and sample.

3.1.2 *mixed aniline point*—the minimum equilibrium solution temperature of a mixture of two volumes of aniline, one volume of sample, and one volume of *n*-heptane of specified purity.

## 4. Summary of Test Methods

4.1 Specified volumes of aniline and sample, or aniline and sample plus *n*-heptane, are placed in a tube and mixed mechanically. The mixture is heated at a controlled rate until the two phases become miscible. The mixture is then cooled at a controlled rate and the temperature at which two phases separate is recorded as the aniline point or mixed aniline point.

## 5. Significance and Use

5.1 The aniline point (or mixed aniline point) is useful as an aid in the characterization of pure hydrocarbons and in the analysis of hydrocarbon mixtures. Aromatic hydrocarbons exhibit the lowest, and paraffins the highest values. Cycloparaffins and olefins exhibit values that lie between those for paraffins and aromatics. In homologous series the aniline points increase with increasing molecular weight. Although it occasionally is used in combination with other physical properties in correlative methods for hydrocarbon analysis, the aniline point is most often used to provide an estimate of the

<sup>1</sup> These test methods are under the jurisdiction of ASTM Committee D02 on Petroleum Products and Lubricants and are the direct responsibility of D02.04 on Hydrocarbon Analysis.

Current edition approved Dec. 10, 2001. Published February 2002. Originally published as D 611 – 41 T. Last previous edition D 611 – 01a.

<sup>2</sup> *Annual Book of ASTM Standards*, Vol 05.01.

<sup>3</sup> *Annual Book of ASTM Standards*, Vol 05.05.

<sup>4</sup> *Annual Book of ASTM Standards*, Vol 14.03.

aromatic hydrocarbon content of mixtures.

## 6. Apparatus

6.1 For details of the aniline point apparatus required for each method see:

Annex A1 for Method A  
Annex A2 for Method B  
Annex A3 for Method C  
Annex A4 for Method D  
Annex A5 for Method E

NOTE 1—Alternative apparatus may be used, such as the U-tube method for dark oils, provided it has been shown to give results of the same precision and accuracy as those described in the Annexes.

6.2 *Heating and Cooling Bath*—A suitable air bath, a nonvolatile, transparent liquid bath, or an infrared lamp (250 to 375 W), provided with means for controlling the rate of heating.

NOTE 2—Water should not be used as either a heating or cooling medium since aniline is hygroscopic and moist aniline will give erroneous test results. For example, the aniline point of the *n*-heptane reagent as measured with aniline containing 0.1 volume % water is approximately 0.5°C (0.9°F) higher than that measured with dry aniline. If the aniline point is below the dew point of the atmosphere, pass a slow stream of dry inert gas into the aniline point tube to blanket the aniline-sample mixture.

6.3 *Thermometers*, or other temperature sensing devices, such as thermocouples or platinum resistance thermometers that cover the temperamental range of interest and can provide equivalent or better accuracy and precision, may be used in place of the thermometers having the following ranges and conforming to the requirements of the designated ASTM or IP specification:

Range	ASTM (Specification E 1)	IP
−38 to + 42°C (−36.5 to + 107.5°F)	33C, 33F	20C
25 to 105°C (77 to 221°F)	34C, 34F	21C
90 to 170°C (194 to 338°F)	35C, 35F	59C

6.4 *Pipets*, or equivalent volume dispensing devices, capable of delivering volumes with capacities of 10 ± 0.04 mL and 5 ± 0.02 mL, for use in the test.

6.5 *Balance*—A laboratory balance sensitive to 0.01 g, suitable for weighing the tube and sample when the sample cannot be pipetted conveniently.

6.6 *Safety Goggles*.

6.7 *Plastic Gloves*, impervious to aniline.

## 7. Reagents

7.1 *Aniline* (**Warning**—Aniline should not be pipetted directly by mouth because of its extreme toxicity. Aniline is also toxic by absorption through the skin even in *very small quantities*, and should be handled with great caution.) Distill chemically pure aniline and dry as needed to meet purity requirements for use, discarding the first and last 10 %. Aniline thus prepared when tested with *n*-heptane according to Section 9 shall give an aniline point of 69.3 ± 0.2°C (156.7 ± 0.4°F) as determined from the average of two independent tests having a difference of not more than 0.1°C (0.2°F).

NOTE 3—For routine purposes the distillation process is not mandatory provided the aniline meets the requirements of the test with *n*-heptane.

NOTE 4—The aniline point of aniline and *n*-heptane determined with automatic apparatus (Method E) shall be 69.3 ± 0.2°C (156.7°F ± 0.4°F)

when corrected in accordance with the equation in Section A5.2.1

NOTE 5—As an alternative to distilling the aniline on the day of use, the aniline may be distilled as described in 7.1, collecting the distillate in ampoules, sealing the ampoules under vacuum or dry nitrogen, and storing in a cool dark place for future use. Alternatively, distillate may be stored under dry nitrogen in a glass bottle or in single use ampoules kept in a cool, dark place. In either case, rigid precaution must be taken to avoid contamination from atmospheric moisture (Note 2). It is believed that under these conditions the aniline will remain unchanged for a period exceeding 6 months.

7.2 *Calcium Sulfate*, anhydrous.

7.3 *n-Heptane* (**Warning**—Flammable. Harmful if inhaled. Keep away from heat, sparks, and open flame. Use with adequate ventilation. Avoid prolonged breathing of vapor or spray mist. Avoid prolonged or repeated skin contact), spectroscopic or HPLC grade.

## 8. Sample

8.1 Dry the sample by shaking vigorously for 3 to 5 min with about 10 volume % of a suitable drying agent such as anhydrous calcium sulfate or anhydrous sodium sulfate. Reduce the viscosity of viscous samples by warming to a temperature below that which would cause the loss of light ends or the dehydration of the drying agent. Remove any suspended drying agent by use of a centrifuge or by filtration. Heat samples containing separated wax until they are homogeneous and keep heated during filtration or centrifugation to ensure against separation of wax. When suspended water is visibly present and the sample material is known to dissolve less than 0.03 mass % of water, the use of a centrifuge for the removal of suspended water is an acceptable procedure.

## 9. Procedure for Aniline Point

9.1 The following methods, to be used as applicable, are covered as follows:

9.1.1 *Method A*, described in detail in Annex A1, is applicable to clear samples or to samples not darker than No. 6.5 ASTM color, as determined by Test Method D 1500, having initial boiling points well above the expected aniline point.

9.1.2 *Method B*, described in detail in Annex A2, is applicable to light-colored samples, moderately dark samples, and to very dark samples. It is suitable for samples that are too dark to be tested by Method A.

9.1.3 *Method C*, described in detail in Annex A3, is applicable to clear samples or to samples not darker than No. 6.5 ASTM color, as determined by Test Method D 1500, having initial boiling points sufficiently low as to give incorrect aniline point readings by Method A, for example, aviation gasoline.

9.1.4 *Method D*, described in detail in Annex A4, is applicable to the same type of sample as Method C. It is particularly useful when only limited quantities of sample are available.

9.1.5 *Method E* is applicable when using automatic apparatus in accordance with the instructions in Annex A5.

## 10. Procedure for Mixed Aniline Point

10.1 This procedure is applicable to samples having aniline points below the temperature at which aniline crystallizes from the mixture. Deliver 10 mL of aniline (**Warning**: See 7.1), 5 mL of sample, and 5 mL of *n*-heptane into a clean, dry apparatus. Determine the aniline point of the mixture by

Method A or B as described in Annex A1 or Annex A2.

## 11. Report

11.1 If the range of three successive observations of the aniline point temperature is not greater than 0.1°C (0.2°F) for light-colored samples or 0.2°C (0.4°F) for dark samples, report the average temperature of these observations, corrected for thermometer calibration errors, to the nearest 0.05°C (0.1°F) as the aniline point.

11.2 If such a range is not obtained after five observations, repeat the test using fresh quantities of aniline and sample in a clean, dry apparatus, and if consecutive temperature observations show a progressive change, or if the range of observations is greater than the repeatability given in 12.1, report the method as being inapplicable.

## 12. Precision and Bias

12.1 The precision of these test methods as obtained by statistical examination of interlaboratory test results is as follows:

12.1.1 *Repeatability*—The difference between successive test results (two average temperatures obtained in a series of observations as described in Section 11 obtained by the same operator with the same apparatus under constant operating conditions on identical test material, would in the long run, in the normal and correct operation of the test method, exceed the following values only in one case in twenty:

		Repeatability	
Aniline point of:			
Clear, light-colored samples	0.16°C	(0.3°F)	

Moderately dark to very dark samples	0.3°C	(0.6°F) <sup>A</sup>
Mixed aniline point of:		
Clear, light-colored samples	0.16°C	(0.3°F) <sup>A</sup>
Moderately dark to very dark samples	0.3°C	(0.6°F) <sup>A</sup>

<sup>A</sup>Not determined from recent cooperative tests; however, the ratios with those given in the 1953 version are believed to apply.

12.1.2 *Reproducibility*—The difference between two single and independent results, obtained by different operators, working in different laboratories on identical test material, would in the long run, in the normal and correct operation of the test method, exceed the following values only in one case in twenty:

12.2 *Bias*—A statement of bias is now being developed by the subcommittee.

		Reproducibility
Aniline point of:		
Clear, light-colored samples	0.5°C	(0.9°F)
Moderately dark to very dark samples	1.0°C	(1.8°F) <sup>A</sup>
Mixed aniline point of:		
Clear, light-colored samples	0.7°C	(1.3°F) <sup>A</sup>
Moderately dark to very dark samples	1.0°C	(1.8°F) <sup>A</sup>

<sup>A</sup>Not determined from recent cooperative tests; however, the ratios with those given in the 1953 version are believed to apply.

12.3 The precision of this test was not obtained in accordance with Committee D-2 Research Report RR:D02-1007, "Manual on Determining Precision Data for ASTM Methods on Petroleum Products and Lubricants."

## 13. Keywords

13.1 aniline point; aromatics; mixed aniline point

## ANNEXES

### (Mandatory Information)

#### A1. METHOD A

##### A1.1 Apparatus

A1.1.1 The apparatus shown in Fig. A1.1 shall consist of the following:

A1.1.1.1 *Test Tube*, approximately 25 mm in diameter and 150 mm in length, made of heat-resistant glass.

A1.1.1.2 *Jacket*, approximately 37 to 42 mm in diameter and 175 mm in length, made of heat-resistant glass.

A1.1.1.3 *Stirrer*, manually operated, metal, approximately 2 mm in diameter (14 B&S gage) metal wire as shown in Fig. A1.1. A concentric ring shall be at the bottom, having a diameter of approximately 19 mm. The length of the stirrer to a right-angle bend shall be approximately 200 mm. The right-angle bend shall be approximately 55 mm long. A glass sleeve approximately 65 mm in length of 3-mm inside diameter shall be used as a guide for the stirrer. Any suitable mechanical device for operating the stirrer as specified is an approved alternative for the manual operation.

##### A1.2 Procedure

A1.2.1 Clean and dry the apparatus. Deliver 10 mL of aniline (**Warning**— see 7.1) and 10 mL of the dried sample (8.1) into the test tube fitted with stirrer and thermometer. If the material is too viscous for volumetric transfer, weigh to the nearest 0.01 g a quantity of the sample corresponding to 10 mL at room temperature. Center the thermometer in the test tube so that the immersion mark is at the liquid level, making sure that the thermometer bulb does not touch the side of the tube. Center the test tube in the jacket tube. Stir the mixture rapidly using a 50-mm (2-in.) stroke, avoiding the introduction of air bubbles.

A1.2.2 If the aniline-sample mixture is not miscible at room temperature, apply heat directly to the jacket tube so that the temperature rises at a rate of 1 to 3°C (2 to 5°F)/min by removing or reducing the heat source until complete miscibility is obtained. Continue stirring and allow the mixture to cool at a rate of 0.5 to 1.0°C (1.0 to 1.8°F)/min. Continue cooling to

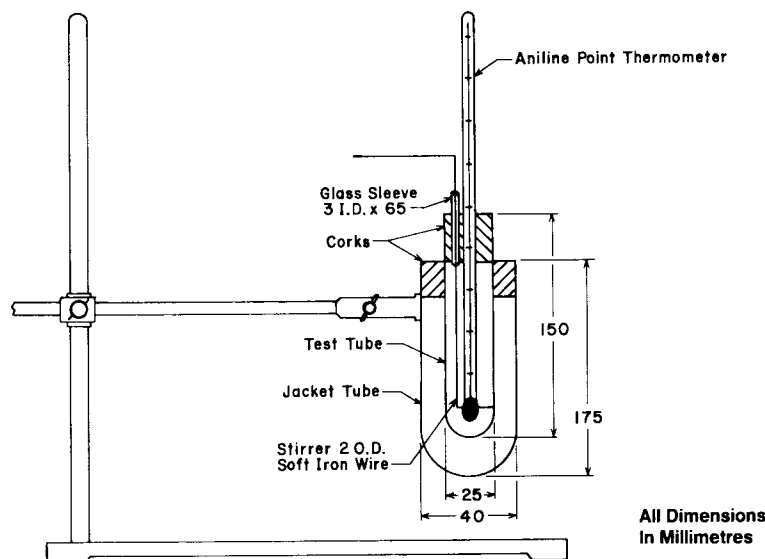

**FIG. A1.1 Aniline Point Apparatus (Method A)**

a temperature of 1 to 2°C (2.0 to 3.5°F) below the first appearance of turbidity, and record as the aniline point the temperature at which the mixture suddenly becomes cloudy throughout (Note A1.1). This temperature, and not the temperature of separation of small amounts of material, is the minimum equilibrium solution temperature.

NOTE A1.1—The true aniline point is characterized by a turbidity that is so cloudy as to obscure the thermometer bulb in reflected light.

A1.2.3 If the aniline-sample mixture is completely miscible at room temperature, substitute a non-aqueous cooling bath for the heating source, allow to cool at the rate specified in A1.2.2 and determine the aniline point as described.

A1.2.4 Repeat the observation of aniline point temperature by heating and cooling repeatedly until a report as directed in Section 11 can be made.

## A2. METHOD B

### A2.1 Apparatus

A2.1.1 *Thin-Film Apparatus*, made of heat-resistant glass and stainless steel, conforming to the dimensions given in Fig. A2.1. A suggested assembly is shown in Fig. A2.2.

### A2.2 Procedure

A2.2.1 Clean and dry the apparatus. Deliver 10 mL of aniline (**Warning**— see 7.1) and 10 mL of the dried sample (8.1) into the tube fitted with pump-stirrer and thermometer. If the material is too viscous for volumetric transfer, weigh to the nearest 0.01 g a quantity of sample corresponding to 10 mL at room temperature. Place the thermometer in the tube so that the contraction chamber is below the liquid level and so that the mercury bulb does not touch the side of the tube. Assemble the apparatus as shown in Fig. A2.2.

A2.2.2 Adjust the speed of the pump to produce a continuous stream of the oil-aniline mixture in the form of a thin film flowing over the light well. With extremely dark oils, operate the pump slowly and lower it so that the delivery tube nearly touches the top of the light well, so as to obtain a continuous film thin enough to permit observation of the aniline point. Adjust the voltage on the lamp until just enough light is given for the filament to be visible through the film. Raise the temperature of the mixture at a rate of 1 to 2°C (2.0 to 3.5°F)/min until the aniline point has just been passed, as denoted by a definite, sudden brightening of the lamp filament,

and by the disappearance of the more or less opalescent condition of the film (Note A2.1). Discontinue heating and adjust the lamp voltage so that the filament appears clear and distinct but not uncomfortably bright to the eye. Adjust the temperature of the bath so that the sample-aniline mixture cools at a rate of 0.5 to 1.0°C (1.0 to 1.8°F)/min and note the appearance of the film and light filament. Record as the aniline point the temperature at which a second phase appears as evidenced by the reappearance of the opalescent condition of the film (usually causing a halo to appear around the lamp filament) or by a sudden dimming of the lamp filament, or both. At temperatures above the aniline point the edges of the light filament appear clear and distinct. At the aniline point temperature a halo or haze forms around the filament, replacing the distinct lines of the filament edge with lines that appear cloudy or hazy in appearance. Further darkening of the cloud over the filament occurs at lower temperature, but is not to be confused with the aniline point.

NOTE A2.1—For those making the test for the first time, the following procedure may be helpful: Make preliminary operational adjustments and tests using a colorless sample-aniline mixture, and observing changes taking place in the body of the liquid and film. Make rough tests with dark oils to become familiar with the appearance of the film and light source as the mixture passes from the clear state above the aniline point, to the translucent state below. If the sample is such that there is difficulty in observing the exact point of the phase change, make experiments with the

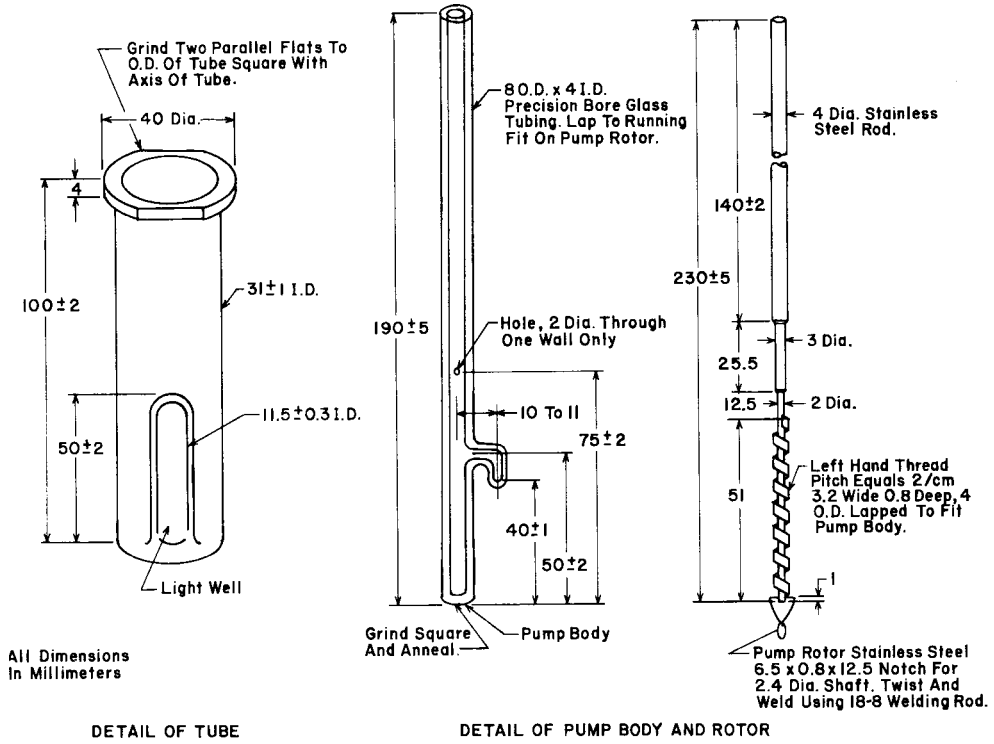

FIG. A2.1 Details of Aniline Point Thin-Film Apparatus (Method B)

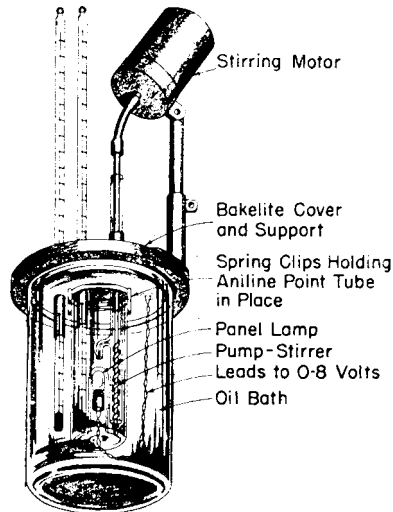

FIG. A2.2 Assembly of Thin-Film Apparatus (Method B)

sample, using various intensities of light and paying particular attention to the appearance of the light in the immediate vicinity of the lamp filament.

by heating and cooling repeatedly until a report as directed in Section 11 can be made.

A2.2.3 Repeat the observation of aniline point temperature

### A3. METHOD C

#### A3.1 Apparatus

A3.1.1 *Aniline-Point Tube*, of heat-resistant glass, of the shape and dimensions shown in Fig. A3.1, and fitted internally with a thin-walled glass thermometer tube, sealed at the lower end. The latter tube accommodates a tight-fitting cork stopper carrying the thermometer, the bulb of which rests on a cork ring or disk placed at the bottom of the tube; the tube contains

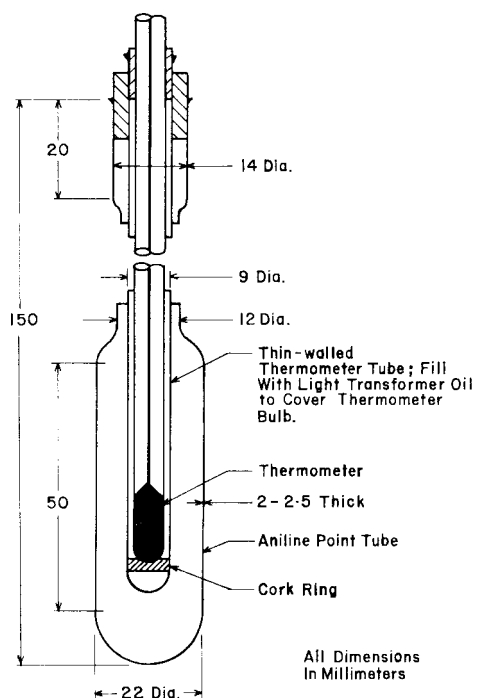

FIG. A3.1 Apparatus for Volatile Samples (Method C)

sufficient light transformer oil to cover the bulb of the thermometer. The inner tube is held in the top of the aniline-point tube by a tightly fitting stopper, and a clamp is provided to hold the stopper in position to prevent loss of vapor from the sample.

NOTE A3.1—Any other suitable arrangement, such as a screwed plastic gland carrying the thermometer, that will prevent the loss of vapor from the apparatus, may be used. In such cases it may be possible to omit the thermometer tube and immerse the thermometer bulb in the aniline-sample mixture.

A3.1.2 *Guard*, of stout metal gauze and surrounding the aniline point tube. It should preferably be combined with the clamp for holding the thermometer tube in place.

#### A3.2 Procedure

A3.2.1 Clean and dry the apparatus. Deliver 5 mL of aniline (**Warning**—Put on goggles of safety glass and plastic gloves impervious to aniline. Also see 7.1.) and 5 mL of the dried sample (8.1), both cooled to a temperature at which the sample may be measured without loss of vapor. Close the tube by means of the stopper and fit the thermometer tube centrally so that the bottom is 5 mm from the bottom of the aniline point tube. Clamp the stopper in position and attach the guard.

A3.2.2 Follow the procedure described in A1.2.2 and A1.2.3 but mix the sample and aniline by shaking the tube. If the rate of change of temperature is greater than 1°C (2°F)/min when the aniline point is being approached, place the tube in a jacket that has previously been warmed or cooled to an appropriate temperature.

A3.2.3 Repeat the observation of aniline point by heating and cooling repeatedly until a report as directed in Section 11 can be made.

### A4. METHOD D

#### A4.1 Apparatus

A4.1.1 *Bulb*, 1.5 to 2.0-mL capacity, blown from heat-resistant glass tubing, 5 mm in external diameter and 3 mm in internal diameter.

A4.1.2 *Guard*, as for Method C.

#### A4.2 Procedure

A4.2.1 Dry the bulb thoroughly in an oven at  $105 \pm 5^\circ\text{C}$ , allow it to cool to room temperature, and charge it by means of the pipets with 0.5 mL of aniline (**Warning**— see 7.1) and 0.5 mL of the dried sample (8.1). Cool the mixture thoroughly and

rapidly draw out and seal the open end of the bulb at about 10 mm from the center of the bulb. (**Warning**—Put on goggles of safety glass and plastic gloves impervious to aniline.)

A4.2.2 Attach the bulb to the thermometer by rubber bands so that the bulb is adjacent to the thermometer bulb. Attach the mesh guard and follow the procedure described in A1.2.2 and A1.2.3 but mix the sample and aniline by shaking.

A4.2.3 Repeat the observation of aniline point temperature by heating and cooling repeatedly until a report as directed in Section 11 can be made.

## A5. METHOD E

### A5.1 Apparatus

A5.1.1 *Automatic Aniline Point Apparatus*, commercially available, using a modified thin film technique and direct heating of the sample-aniline mixture with electrical immersion heater. Detection of change of sample turbidity at the aniline point is by response of a photoelectric cell to collimated

light directed through the thin film of sample.

### A5.2 Procedure

A5.2.1 Determine the automatic aniline point in accordance with instructions provided with the apparatus.

## A6. PRECAUTIONARY STATEMENT

### A6.1 *n*-Heptane

**Warning**—Flammable. Harmful if inhaled.  
Keep away from heat, sparks, and open flame.  
Keep container closed.

Use with adequate ventilation.  
Avoid prolonged breathing of vapor or spray mist.  
Avoid prolonged or repeated skin contact.

*ASTM International takes no position respecting the validity of any patent rights asserted in connection with any item mentioned in this standard. Users of this standard are expressly advised that determination of the validity of any such patent rights, and the risk of infringement of such rights, are entirely their own responsibility.*

*This standard is subject to revision at any time by the responsible technical committee and must be reviewed every five years and if not revised, either reapproved or withdrawn. Your comments are invited either for revision of this standard or for additional standards and should be addressed to ASTM International Headquarters. Your comments will receive careful consideration at a meeting of the responsible technical committee, which you may attend. If you feel that your comments have not received a fair hearing you should make your views known to the ASTM Committee on Standards, at the address shown below.*

*This standard is copyrighted by ASTM International, 100 Barr Harbor Drive, PO Box C700, West Conshohocken, PA 19428-2959, United States. Individual reprints (single or multiple copies) of this standard may be obtained by contacting ASTM at the above address or at 610-832-9585 (phone), 610-832-9555 (fax), or [service@astm.org](mailto:service@astm.org) (e-mail); or through the ASTM website ([www.astm.org](http://www.astm.org)).*