



# Standard Guide for Flood Testing Horizontal Waterproofing Installations<sup>1</sup>

This standard is issued under the fixed designation D 5957; the number immediately following the designation indicates the year of original adoption or, in the case of revision, the year of last revision. A number in parentheses indicates the year of last reapproval. A superscript epsilon ( $\epsilon$ ) indicates an editorial change since the last revision or reapproval.

## 1. Scope

1.1 The purpose of this guide is to provide the user with a method for testing the watertightness of waterproofing installations applied to horizontal surfaces having a slope not greater than 1/4 in. per ft (2 % slope) (20 mm/m).

1.2 This guide is intended for waterproofing installation on parking garages and plaza deck type applications over habitable spaces or on elevated structures, but is not intended for use on building roofing systems. Applicable waterproofing membrane installations, which may be tested using this guide, are fully adhered or bonded sheet membranes, liquid or fluid applied membranes, or loose laid sheet membranes.

1.3 The procedures presented here are not intended for use on those waterproofing installation applications that are for long-term water storage or continuously submerged environments, such as swimming pools, fountains, tank liners with hydrostatic pressure, or water storage units (storage period greater than 48 h).

1.4 The values stated in inch-pound units are to be regarded as the standard. The values given in parentheses are for information only.

1.5 *This standard does not purport to address all of the safety concerns, if any, associated with its use. It is the responsibility of the user of this standard to establish appropriate safety and health practices and determine the applicability of regulatory limitations prior to use.*

## 2. Referenced Documents

### 2.1 ASTM Standards:

D 1079 Terminology Relating to Roofing, Waterproofing, and Bituminous Materials<sup>2</sup>

### 2.2 ACI Document:

ACI 515 Guide to the Use of Waterproofing, Dampproofing, Protective, and Decorative Barrier Systems for Concrete<sup>3</sup>

## 3. Terminology

3.1 For definitions of terms relating to roofing and waterproofing, see Terminology D 1079.

<sup>1</sup> This guide is under the jurisdiction of ASTM Committee D-8 on Roofing, Waterproofing, and Bituminous Materials and is the direct responsibility of Subcommittee D08.22 on Waterproofing and Dampproofing Systems.

Current edition approved Jan. 10, 1998. Published September 1998. Originally published as D 5957-96. Last previous edition D 5957-96.

<sup>2</sup> *Annual Book of ASTM Standards*, Vol 04.04.

<sup>3</sup> Available from the American Concrete Institute, P. O. Box 19150, Redford Station, Detroit, MI 48219.

## 3.2 Definition of Term Specific to This Standard:

3.2.1 *sacrificial sheet*—a material used to form a temporary seal between a containment assembly and the waterproofing system. The material used for a sacrificial sheet shall not cause damage nor be detrimental to the primary system.

## 4. Summary of Guide

4.1 This guide uses a series of temporary containment assemblies of pond water on horizontal surfaces to determine the watertightness of waterproofing installations.

4.2 The area to be tested is subdivided as required by the containment assemblies, and drains within the subdivided area are temporarily blocked to prevent water leakage into the drainage system.

4.3 Water is ponded in the subdivided area and maintained for a minimum period of 24 h. The space below the test location is monitored for leakage during the test period.

## 5. Significance and Use

5.1 This guide describes the techniques used to test for watertightness of waterproofing installations on horizontal services having a slope not greater than 1/4 in./ft (2 % slope) (20 mm/m). See also ACI 515.

5.2 The structural capacity of the substrate to which the waterproofing system is to be installed should be reviewed by a licensed structural engineer to verify that the loads associated with the use of procedures described in this guide do not exceed code and design restrictions. Lateral loads will be imposed on curbs or walls used for containment of the water during the test procedures and their effect should be accounted for. The effects of equipment, planters, or other movable objects present within the test area should be considered.

NOTE 1—Potable water weighs approximately 62.3 lbs per cubic ft (1000 kg/cubic m) at 71.6°F (22°C) or 5.19 lbs/ft<sup>2</sup> per in. depth (1 g/cm<sup>2</sup>/cm depth).

5.3 This guide describes a procedure to test for watertightness of waterproofing installations under ponded water with a short-term hydrostatic head measuring not more than 4 in. (100 mm).

NOTE 2—Increasing the amount of water forming a hydrostatic head beyond 4 in. (100 mm) of water may be considered provided the impact of increased loads on the substrate has been reviewed and approved by a licensed structural engineer.

5.4 For the purposes of this guide, the installation of the waterproofing membrane and flashing should be completed and

the materials fully cured. Manufacturers should specify a minimum time period for materials to cure prior to performing flood test, however, no testing should be performed during the first 24 h following installation of system materials (48 h min if materials are installed at a time when ambient temperatures are below 50°F (10°C)).

5.5 The additional loads imposed upon the structure during the test period will affect the deflection of structural items. The effects shall be analyzed by a licensed structural engineer prior to placement of additional loads. Critical locations shall be monitored during the duration of the test period.

5.6 This guide is not recommended to be used if freezing temperatures are expected to occur during the test period. Ponded water can freeze and become adhered to the waterproofing system resulting in pulling or tearing of the flashings away from the substrate or may break interior corners.

5.7 The intent of this guide is to provide a measure of confidence of the waterproofing installation to remain watertight for the service life of the system, based upon the observed performance of the system under ponded water for a limited period of time.

**6. Materials**

6.1 *Drain Plugs*—Pneumatically inflatable devices consisting of a rubber ball, draw chain and ring, and preset, built-in pressure relief valve; compression plugs having a screw mechanism; or other standard plumbing fixtures.

6.2 *Standard Air Pressure Hand Pump with Hose*—Pressure gage is optional.

6.3 *Vertical-Sided Shallow Pan.*

6.4 *Containment Assemblies*—Assemblies to form temporary dams can be constructed using one or more of the following materials. Refer to Figs. 1-4, for examples of constructed containment assemblies.

6.4.1 Nominal 2-in. (50-mm) thick by 4 or 6-in. (100 or 150-mm) wide wood members,

6.4.2 Polyethylene film having a minimum thickness of 6 mils,

6.4.3 Sandbags,

6.4.4 Duct tape,

6.4.5 Waterproofing membrane materials,

6.4.6 Adhesives and sealants,

6.4.7 Scale or similar measuring device, and

6.4.8 Extruded or expanded polystyrene insulation boards, approximately 12 in. (30 cm) wide.

6.5 *Garden Hoses or Firehoses*—Standard size.

NOTE 3—If firehoses are used, then set the hose of a flow disperser such that the nozzle and initial flow are not in direct contact with the membrane.

6.6 *Plastic Bucket*—Standard wash bucket with bottom panel removed. Four holes measuring approximately 1 in. (25.4 mm) diameter equally spaced around the bucket at approximately 1 in. from the bottom.

**7. Procedure**

7.1 Testing should be performed only after waterproofing membrane and flashings are inspected and any deficiencies repaired.

7.2 Testing prior to installation of drainage layer, protection layer, pavers or overburden. (See also Appendix X1.)

7.3 If a protection layer is required prior to flood testing, it is recommended that a temporary protection layer be loose laid and removed prior to testing of the waterproofing system.

7.4 *Installation of Temporary Containment Assemblies:*

7.4.1 Construct containment assemblies to be nondestructive, nonpenetrating of the waterproofing installation, and easily removable.

7.4.2 Containment assemblies consist of a sacrificial sheet or a polyethylene sheet adhered to the surface of the waterproofing membrane. Seal the sheet as recommended by the waterproofing membrane manufacturer, or seal it by using a watertight seal, such as duct tape or similar material. Following completion of the testing, cut the sacrificial sheet around the adhered portion, leaving the adhered portion in-place unless otherwise required by the membrane manufacturer.

7.4.3 Containment assemblies also may consist of materials that are the same or compatible with the installed waterproofing system. Such materials could include felts, sheet membrane, and sealants. These materials can be installed in a manner similar to that used for night tie-offs, which can be removed after the flood test or left in-place, depending on the waterproofing system utilized.

7.4.4 Securely wrap and attach the sacrificial or polyethylene sheet to the containment frame.

7.4.5 Sandbags can be used to hold the containment frame or may be used in place of the frame and in conjunction with the polyethylene sheet. Seal the polyethylene sheet to the waterproofing membrane as noted above. Make certain that the weight of the sandbags or similar ballast is equivalent to

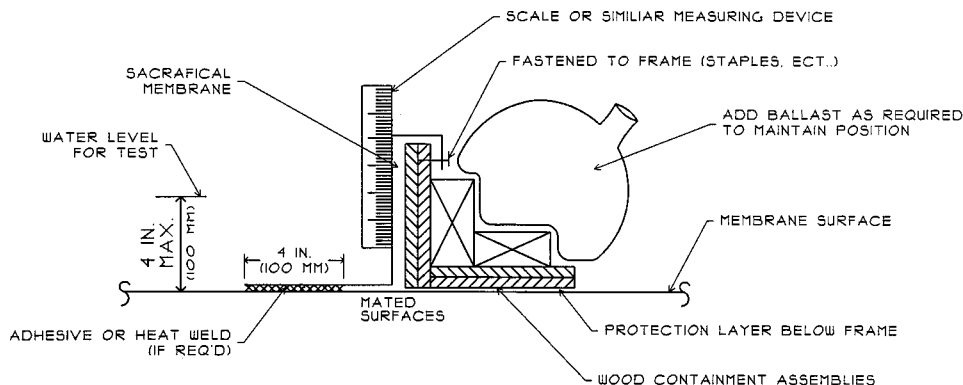

FIG. 1 Containment Assembly—Option No. 1

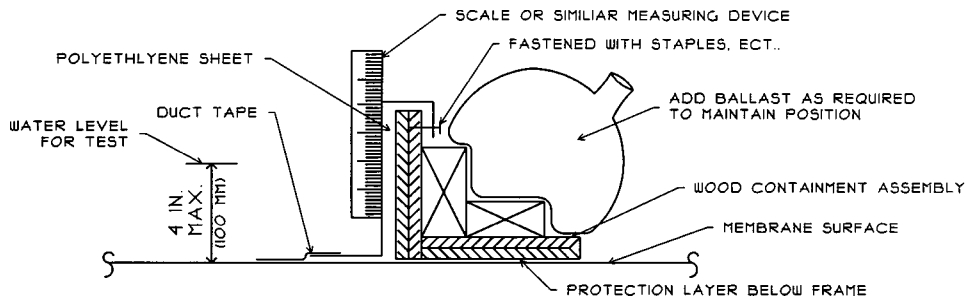

FIG. 2 Containment Assembly—Option No. 2

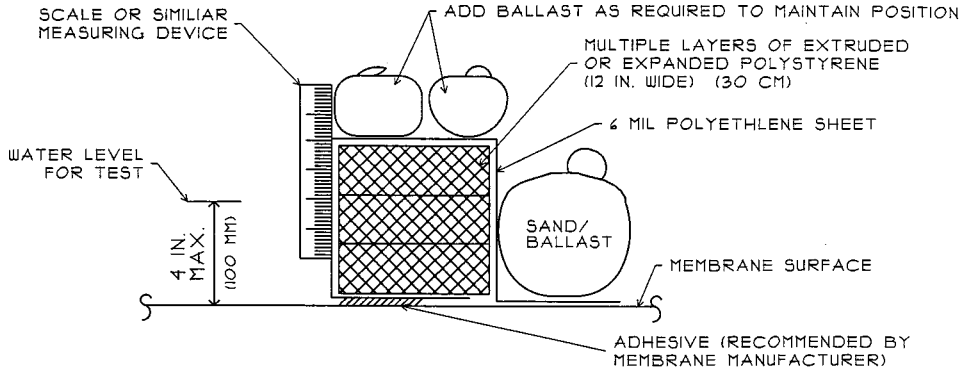

FIG. 3 Containment Assembly—Option No. 3

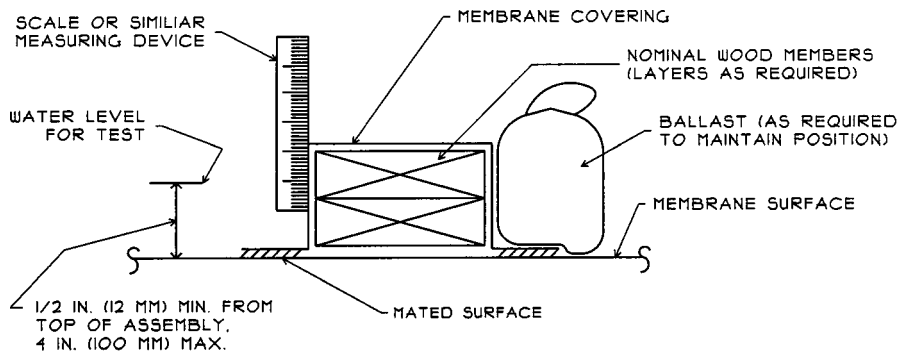

FIG. 4 Containment Assembly—Option No. 4

approximately 7 lbs per linear ft (10.4 kg per linear m) of containment frame or assembly.

7.4.6 Base the location and number of containment assemblies upon limitations established in this procedure, so as not to exceed the maximum ponded water heights.

7.4.7 Provide overflows in the containment assemblies unless the existing system has overflows already incorporated. Take care not to block existing overflows and to limit the height of the containment assemblies, so as not to exceed the structural capacity of the substrate. Make certain that the overflows in the containment assemblies are located not higher than 5 in. (125 mm) above low point of the test surface.

7.4.8 Install tapes with markings noted at 1/8 in. (3 mm) max, or a ruler or other scale instrument in at least two locations on the containment walls to allow for monitoring water loss.

7.5 Plug all drains within the segmented area with inflatable plugs. Fill area around sump of drain with water, and check for leakage around the plug before proceeding with testing the full segmented area.

7.6 Flood segmented area with potable water to achieve a minimum cover of 1 in. (25 mm) and not to exceed a maximum depth of 4 in. (100 mm) at low point of test area. Do not exceed 2 1/2 in. (65 mm) for mean water depth. Hoses used to flood the test area should be located away from laps in the membrane and the water aimed to flow with the laps and not against the lap's edges.

7.7 Maintain water in the test area so as not to exceed a minimum level of 2 in. (50 mm) below the top edge of flashings.

7.8 Prior to beginning the flood test, take the following precautions:

7.8.1 Observe existing conditions and elements within the test area that may be sensitive to water leakage during the test;

7.8.2 Notify occupants when the test is to be performed;

7.8.3 Develop contingency plans to be enacted should leakage occur; and,

7.8.4 Testing should not be performed if rain is anticipated to occur during the test period.

7.9 In a location immediately adjacent to the test area,

partially fill a flat-bottom, vertical-sided shallow pan to the approximate depth of water in the adjacent test area. Expose the surface to comparable wind conditions as the test area, throughout the test. At predetermined locations, measure the depth of the water at both the start and conclusion of the test period. Calculate the changes in water depth in both the test area and the pan. If the difference in depth in the area is substantially greater than the pan, membrane leakage is probable and the test area should be drained and the area examined for the location of leakage.

#### 7.10 Flood Test Period:

7.10.1 Perform continuous flood testing for a minimum time interval of 24 h. Begin the test period at the time the water has obtained the recommended test depth.

7.10.2 Perform continuous flood testing for a maximum time interval of 72 h. Do not perform continuous flood testing over a weekend unless persons are present to monitor the test.

7.11 Should rain occur during the test period, discontinue testing to avoid flooding over the edge of the flashings. The addition of rain water to the test area may render the measurements of draw-down or added water inaccurate.

7.12 Provide constant monitoring during the full duration of the flood test. Document conditions observed below the test area before beginning the flood test and at four hour intervals until completion of the flood test.

7.13 If leakage is detected during the test period, immediately drain water from the test area as described in 7.16, determine the location of leakage, and make appropriate repairs to the system.

7.14 Make repairs to the waterproofing system in a manner consistent with the system design and in accordance with the system manufacturer's recommendation for procedures and materials.

7.15 Following the completion of the repairs and curing of materials, retest the area under the same conditions as the initial flood test.

7.16 When draining the test area, slowly release the drain plugs to avoid damage to the drain system and to avoid personal injury. Uncontrolled discharge can damage the drain system. Alternately, use an open-ended bucket with holes, placed over the drain when releasing the drain plug. The bucket shall be plastic with the bottom removed and with four, 1 in.

(25.4 mm) holes located near the bottom (below water level) of the bucket. Holes may be covered with duct tape to control the flow of water into the bucket area by removing tape as necessary to achieve desired rate.

7.17 Flood test is considered to be completed if no leaks are determined to have occurred during the test period and the membrane and flashings are intact (for example, not blistered).

7.18 Following the test procedure, reinspect the installation including seams (as applicable) for evidence of water leakage, blisters, or similar adverse conditions.

## 8. Report

8.1 Prepare a written report documenting the flood test procedure and include, but do not limit it to, the following information:

- 8.1.1 Date and time at start of test interval;
- 8.1.2 Location of test area, which may include a plan drawing indicating test area, locations of temporary containment assemblies, drains and similar items;
- 8.1.3 Temperature, humidity, and weather;
- 8.1.4 Type of substrate construction (include obstruction to observations);
- 8.1.5 Type of waterproofing system (manufacturer if known);
- 8.1.6 Areas inaccessible to observation, above and below the deck;
- 8.1.7 Monitoring of critical items during filling of test area with water;
- 8.1.8 Minimum and maximum depths of water in the test area;
- 8.1.9 Draw-down or added water during the test period;
- 8.1.10 Observations made at beginning of test and at each four-hour time interval;
- 8.1.11 Locations of leaks, if any;
- 8.1.12 Location and method of repairs made, if required; and,
- 8.1.13 Duration of test interval.

## 9. Keywords

9.1 containment assemblies; flood test; ponded water; waterproofing

## APPENDIX

### (Nonmandatory Information)

#### XI. COMPLETION OF FLOOD TESTS

X1.1 Upon completion of the flood test and repairs, if any, it is recommended that all permanent or temporary protection

material be installed to protect the membrane and flashings from foot and construction traffic or other damage.

 **D 5957**

*The American Society for Testing and Materials takes no position respecting the validity of any patent rights asserted in connection with any item mentioned in this standard. Users of this standard are expressly advised that determination of the validity of any such patent rights, and the risk of infringement of such rights, are entirely their own responsibility.*

*This standard is subject to revision at any time by the responsible technical committee and must be reviewed every five years and if not revised, either reapproved or withdrawn. Your comments are invited either for revision of this standard or for additional standards and should be addressed to ASTM Headquarters. Your comments will receive careful consideration at a meeting of the responsible technical committee, which you may attend. If you feel that your comments have not received a fair hearing you should make your views known to the ASTM Committee on Standards, 100 Barr Harbor Drive, West Conshohocken, PA 19428.*