



Standard Test Method for Pour Point of Crude Oils¹

This standard is issued under the fixed designation D 5853; the number immediately following the designation indicates the year of original adoption or, in the case of revision, the year of last revision. A number in parentheses indicates the year of last reapproval. A superscript epsilon (ϵ) indicates an editorial change since the last revision or reapproval.

^{ε1} NOTE—Warning notes were placed in the text editorially in December 2000.

1. Scope

1.1 This test method covers two procedures for the determination of the pour point temperatures of crude oils down to -36°C . One method provides a measure of the maximum (upper) pour point temperature (Procedure A) and is described in 9.1; the other method provides a measure of the minimum (lower) pour point temperature (Procedure B) and is described in 9.2.

1.2 The use of this test method is limited to use for crude oils. Pour point temperatures of other petroleum products can be determined by Test Method D 97.

1.3 *This standard does not purport to address all of the safety concerns, if any, associated with its use. It is the responsibility of the user of this standard to establish appropriate safety and health practices and determine the applicability of regulatory limitations prior to use.* For specific hazard statements, see Section 7.

2. Referenced Documents

2.1 ASTM Standards:

- D 97 Test Method for Pour Point of Petroleum Products²
- D 130 Test Method for Detection of Copper Corrosion from Petroleum Products by the Copper Strip Tarnish Test²
- D 323 Test Method for Vapor Pressure of Petroleum Products (Reid Method)²
- D 4057 Practice for Manual Sampling of Petroleum and Petroleum Products³
- D 4177 Practice for Automatic Sampling of Petroleum and Petroleum Products³
- E 1 Specification for ASTM Thermometers⁴
- E 77 Test Method for Inspection and Verification of Thermometers⁴

¹ This test method is under the jurisdiction of ASTM Committee D02 on Petroleum Products and Lubricants and is the direct responsibility of Subcommittee D02.07 on Flow Properties.

Current edition approved Oct. 10, 1995. Published December 1995.

² *Annual Book of ASTM Standards*, Vol 05.01.

³ *Annual Book of ASTM Standards*, Vol 05.02.

⁴ *Annual Book of ASTM Standards*, Vol 14.03.

3. Terminology

3.1 Definitions of Terms Specific to This Standard:

3.1.1 *pour point, n*—the lowest temperature at which movement of the test specimen is observed under the conditions of the test.

3.1.2 *maximum (upper) pour point, n*—the pour point obtained after the test specimen has been subjected to a prescribed treatment designed to enhance gelation of wax crystals and solidification of the test specimen.

3.1.3 *minimum (lower) pour point, n*—the pour point obtained after the test specimen has been subjected to a prescribed treatment designed to delay gelation of wax crystals and solidification of the test specimen.

4. Summary of Test Method

4.1 After preliminary heating, the test specimen is cooled at a specified rate and examined at intervals of 3°C for flow characteristics. The lowest temperature at which movement of the test specimen is observed is recorded as the pour point.

5. Significance and Use

5.1 The pour point of a crude oil is an index of the lowest temperature of handleability for certain applications.

5.2 This is the only pour point method specifically designed for crude oils.

5.3 The maximum and minimum pour point temperatures provide a temperature window where a crude oil, depending on its thermal history, might appear in the liquid as well as the solid state.

5.4 The test method can be used to supplement other measurements of cold flow behavior. It is especially useful for the screening of the effect of wax interaction modifiers on the flow behavior of crude oils.

6. Apparatus

6.1 Pour Point Test Apparatus Assembly (see Fig. 1):

6.1.1 *Test Jar*, cylindrical, of clear glass, flat bottomed, outside diameter 33.2 to 34.8 mm, and height 115 to 125 mm. The inside diameter of the jar can range from 30.0 to 32.4 mm,

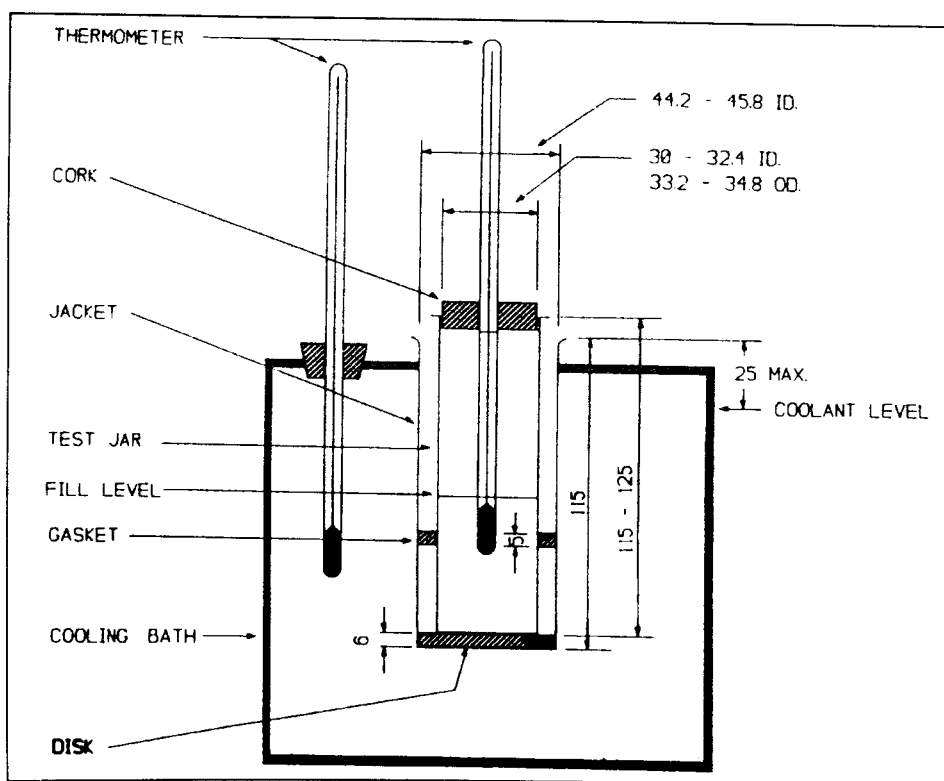

NOTE 1—All dimensions are stated in millimetres.

FIG. 1 Apparatus for Pour Point Test

within the constraint that the wall thickness shall be no greater than 1.6 mm. The jar shall have a line to indicate a sample height 54 ± 3 mm above the inside bottom. The inside of the test jar (up to the mark) shall be visibly clean and free of scratches.

6.1.2 *Thermometers*, having ranges shown in the following table and conforming to the requirements prescribed in Specification E 1 for thermometers:

Thermometer	Temperature Range	Thermometer	
		ASTM	Number IP
High cloud and pour	-38 to +50°C	5C	1C
Low cloud and pour	-80 to +20°C	6C	2C
Melting point	+32 to +127°C	61C	63C

6.1.2.1 Since separation of liquid column thermometers occasionally occurs and may escape detection, the ice point of the thermometers shall be checked prior to the test and used only if they are accurate within $\pm 1^\circ\text{C}$ (see Test Method E 77).

6.1.3 *Cork*, to fit the test jar, center bored for the test thermometer.

6.1.4 *Jacket*, watertight, cylindrical, metal, flat bottomed, 115 ± 3 mm depth, with inside diameter of 44.2 to 45.8 mm. It shall be supported in a vertical position in the cooling bath (6.1.7) so that no more than 25 mm projects out of the cooling medium. The jacket shall be capable of being cleaned.

6.1.5 *Disk*, cork or felt, 6 mm thick to fit loosely inside the jacket.

6.1.6 *Gasket*, to fit snugly around the outside of the test jar and loosely inside the jacket. The gasket shall be made of rubber, leather, or other material that is sufficiently elastic to

cling to the test jar and hard enough to hold its shape. Its purpose is to prevent the test jar from touching the jacket.

6.1.7 *Cooling Bath or Baths*, of a type suitable for obtaining the required temperatures. The size and shape of the bath are options, but a support to hold the jacket firmly in a vertical position is essential. The bath temperature shall be monitored by means of the appropriate thermometer (6.1.2) or any other temperature measuring device capable of measuring and displaying the designated temperature with the required precision and accuracy. The required bath temperatures shall either be maintained by refrigeration or by suitable freezing mixtures (Note 1) and shall maintain the designated temperatures to within $\pm 1.5^\circ\text{C}$.

NOTE 1—The cooling mixtures commonly used are as follows :

	For Temperatures Down To
Ice and water	9°C
Crushed ice and sodium chloride crystals	-12°C
Crushed ice and calcium chloride crystals	-27°C
Acetone or petroleum naphtha (see Section 7) chilled in a covered metal beaker with an ice-salt mixture to -12°C and then with enough solid carbon dioxide to give the desired temperature.	-57°C

6.2 *Water Bath*—The size and shape of the bath are optional, but a support to hold the test jar immersed in the bath to above the sample height in the test jar and in a firm vertical position is required. The required bath temperature may be maintained by any suitable means, provided the temperature can be monitored and controlled to the designated temperature ($\pm 1^\circ\text{C}$ (9.1.4; 9.2.4)).

6.3 *Pressure Vessel*,⁵ constructed of stainless steel according to the dimensions given in Fig. 2, and capable of withstanding a test pressure of 700 kPa. Alternative designs for the pressure vessel cap and synthetic rubber gasket may be used provided that the internal dimensions of the pressure vessel are the same as those shown in Fig. 2.

⁵ This pressure vessel is identical to the pressure vessel described in Test Method D 130.

6.4 *Timing Device*, capable of measuring up to 30 s with a resolution of at least 0.1 s and an accuracy of ± 0.2 s or better.

7. Reagents and Materials

7.1 The following solvents of technical grade are appropriate for low-temperature bath media.

7.1.1 *Acetone*, (**Warning**—Extremely flammable.)

7.1.2 *Alcohol, Ethanol*, (**Warning**—Flammable.)

7.1.3 *Alcohol, Methanol*, (**Warning**—Flammable. Vapor harmful.)

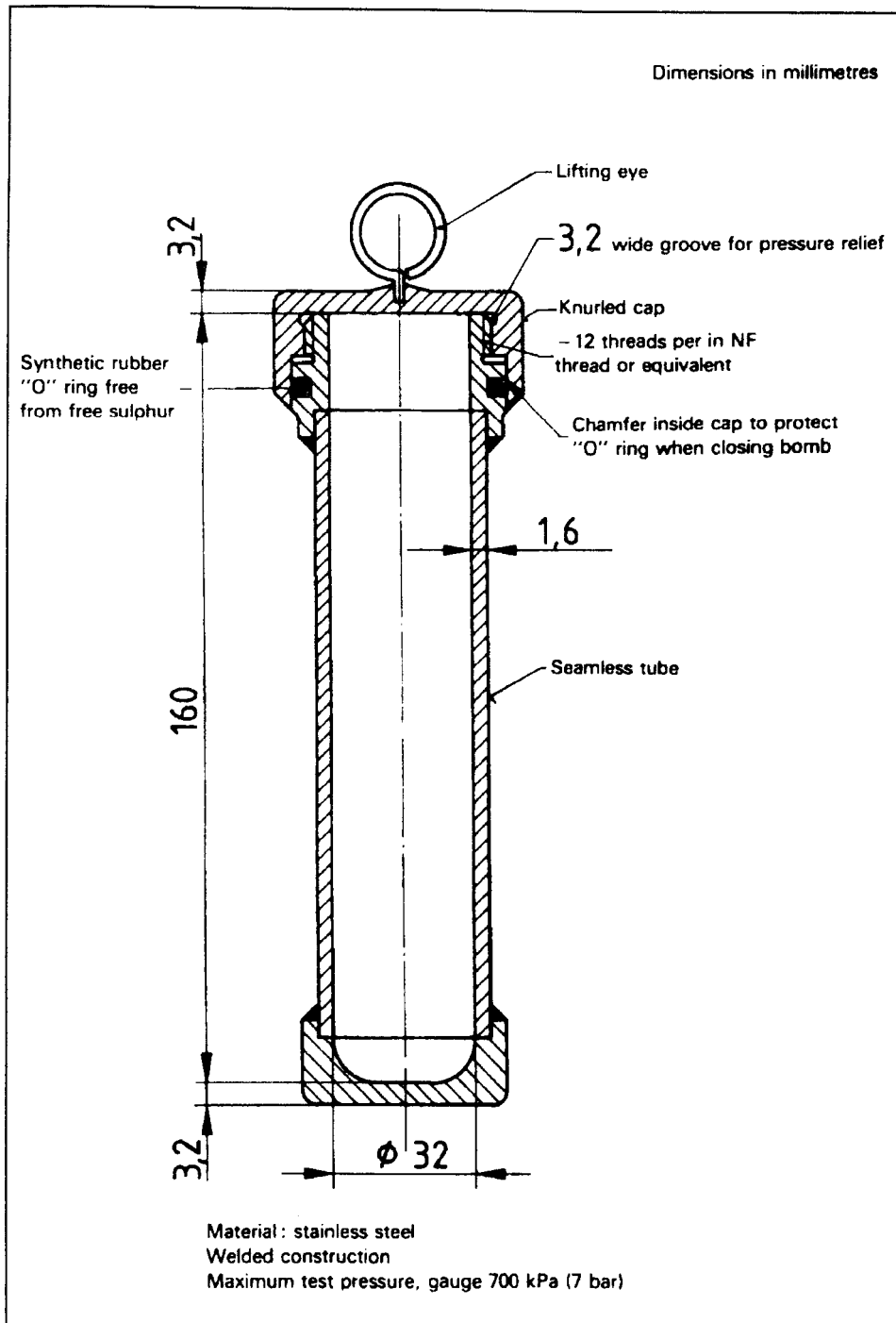

FIG. 2 Pressure Vessel

7.1.4 *Petroleum Naphtha*, (**Warning**—Combustible. Vapor harmful.)

NOTE 2—Typical petroleum naphtha used for cleaning purposes are VM and P naphthas.

7.2 *Toluene*, technical grade (**Warning**—Flammable. Vapor harmful.)

7.3 *Solid Carbon Dioxide*, (**Warning**—Extremely cold (-78.5°C).)

8. Sampling, Test Samples, and Test Specimens

NOTE 3—Sampling is defined as all steps required to obtain a portion of the contents of any pipe, tank, or other system and to place the sample into the laboratory test container.

8.1 *Laboratory Sample*—It is essential that the sample received by the laboratory is representative of the batch or lot of crude oil from which it was taken. Practices D 4057 and D 4177 provide guidance for obtaining such representative samples.

8.2 *Preparation of Test Samples*—The pour point of crude oils is very sensitive to trace amounts of high melting waxes. Exercise meticulous care to ensure such waxes, if present, are either completely melted or, if volatility constraints prevent heating to complete melting, homogeneously suspended in the sample (Appendix X1). Inspect the walls of the original container to ensure that no high melting point material is left sticking to the wall.

NOTE 4—It is not possible to define universal mandatory rules for the preparation of crude oil test samples. Guidelines for sample handling for the most common situations are given in Appendix X1.

9. Procedure

9.1 Procedure A for Maximum (Upper) Pour Point:

9.1.1 Pour the test sample into the test jar to the level mark. If necessary, reheat the test sample to a temperature at least 20°C above the expected pour point (8.2 and Appendix X1) but not higher than a temperature of 60°C (**Warning**—The vapor pressure of crude oils at temperatures higher than 60°C will usually exceed 100 kPa. Under these circumstances the sample container may rupture. Opening of the container may induce foaming with resultant loss of sample and possible injury to personnel.).

9.1.2 Immediately close the test jar with the cork carrying the high cloud and pour thermometer, or, if the expected pour point is above 36°C , the melting point thermometer. Adjust the position of the cork and thermometer so the cork fits tightly, the thermometer and the jar are coaxial, and the thermometer bulb is immersed to a depth that places the beginning of the capillary 3 mm below the surface of the test specimen.

9.1.3 Keep the test jar with the test specimen at room temperature (between 18 and 24°C) for at least 24 h.

NOTE 5—The pour point of a crude oil is dependent on the state of crystallization of the wax in the test specimen. In crude oils, achieving equilibrium between crystallized wax and dissolved wax is a rather slow process. However, experience has shown that in a majority of cases, such an equilibrium is reached within 24 h.

9.1.4 If the expected pour point is greater than 36°C , heat the sample to 9°C above the expected pour point. If the expected pour point is less than 36°C , heat the sample to a

temperature of $45 \pm 1^{\circ}\text{C}$. Maintain the water bath (6.2) to heat the sample at $48 \pm 1^{\circ}\text{C}$ or at a temperature 12°C higher than the expected pour point, whichever is higher.

9.1.4.1 As soon as the test specimen has reached the required temperature, remove the cork carrying the thermometer and stir the test specimen gently with a spatula or similar device. Put the cork carrying the thermometer back in place (see 9.1.2).

9.1.5 Ensure that the disk, gasket, and the inside of the jacket are clean and dry. Place the disk in the bottom of the jacket. Place the disk and jacket in the cooling medium a minimum of 10 min before the test jar is inserted. The use of a jacket cover, while the empty jacket is cooling, is permitted. Remove the test jar from the water bath and dry with a tissue. Place the gasket around the test jar, 25 mm from the bottom. Insert the test jar into the jacket in the first bath maintained at 21°C and commence observations for pour point. Never place a test jar directly into the cooling medium.

9.1.6 Exercise care not to disturb the mass of test specimen nor permit the thermometer to shift in the test specimen; any disturbance of the spongy network of wax crystals will lead to a lower pour point and erroneous results (Note 5).

NOTE 6—With dark colored materials, such as crude oils, it is impractical to observe, in the test jar, the onset of crystallization and network formation in the test specimen. Hence, it is presumed that network formation will begin at the very early stages of the cooling sequence.

9.1.7 Pour points are expressed in temperatures which are positive or negative multiples of 3°C . Begin to examine the appearance of the test specimen when the temperature of the test specimen is 9°C above the expected pour point (estimated as a multiple of 3°C). At each test thermometer reading which is a multiple of 3°C below the starting temperature, remove the test jar from the jacket. When necessary, remove moisture that limits visibility of the test specimen by wiping the surface of the test jar with a clean cloth moistened in alcohol at approximately the temperature of the test specimen in the jar. Then tilt the jar just enough to ascertain whether there is movement of the test specimen in the jar. When movement is observed, immediately return the test jar into the jacket. The complete operation of removal and replacement shall require not more than 3 s.

9.1.7.1 If the test specimen has not ceased to flow when its temperature has reached 30°C , transfer the test jar to the next lower temperature bath per the following schedule:

- (a) If the test specimen is at $+30^{\circ}\text{C}$, move to 0°C bath;
- (b) If the test specimen is at $+9^{\circ}\text{C}$, move to -18°C bath;
- (c) If the test specimen is at -9°C , move to -33°C bath; and
- (d) If the test specimen is at -24°C , move to -51°C bath.

9.1.7.2 As soon as the test specimen in the jar does not flow when tilted, hold the jar in a horizontal position for 5 s, as shown by an accurate timing device (6.4) and observe carefully. If the test specimen shows any movement, replace the test jar immediately in the jacket and repeat a test for flow at the next temperature, 3°C lower.

9.1.8 Continue in this manner until a point is reached at which the test specimen shows no movement when the test jar is held in a horizontal position for 5 s. Record the observed reading of the test temperature.

9.1.8.1 If the test specimen has reached -36°C and still shows movement, discontinue the test.

NOTE 7—To determine compliance with existing specifications having pour point limits at temperatures not divisible by 3°C , it is acceptable practice to conduct the pour point measurement according to the following schedule. Begin to examine the appearance of the test specimen when the temperature of the test specimen is 9°C above the specification pour point. Continue observations at 3°C intervals as described in 9.1.6 and 9.1.7 until the specification temperature is reached. Report the sample as passing or failing the specification limit.

9.2 Procedure B for Minimum (Lower) Pour Point:

9.2.1 Pour 50 g of the test sample into a clean pressure vessel (6.3 and Note 8). When necessary, reheat the test sample to a temperature of at least 20°C above the expected pour point (8.2 and Appendix X1) but not higher than 60°C (**Warning**—The vapor pressure of crude oils at temperatures higher than 60°C will usually exceed 100 kPa. Under these circumstances the sample container may rupture. Opening of the container may induce foaming with resultant loss of sample and possible injury to personnel.). Check that the rubber ring is in place and screw the lid on tightly.

NOTE 8—The pressure vessel may be cleaned by any appropriate solvent, provided the solvent is capable of dissolving remnants of high melting wax and asphaltenes. Hot toluene (100°C) has been found to be an appropriate solvent for this purpose.

9.2.2 Heat the pressure vessel in an oil bath or by any other suitable means to a temperature of $105 \pm 2^{\circ}\text{C}$ and leave at that temperature for at least 30 min.

9.2.3 Take the pressure vessel from the oil bath, wipe and dry the surface of the pressure vessel, swirl gently to homogenize the contents, and leave the pressure vessel to cool at room temperature for exactly 20 min.

9.2.4 Carefully open the pressure vessel and transfer the sample into the test jar filling to the level mark of the test jar, preheated in a water bath (6.2) kept at a temperature of $48 \pm 1^{\circ}\text{C}$ (**Warning**—After 20 min at ambient temperature, the temperature of the test specimen will be approximately 50°C . The vapor pressure at that temperature may still exceed 100 kPa. Under these circumstances, inattentive opening of the pressure vessel may induce foaming with resultant loss of sample and possible injury to personnel.).

9.2.5 Immediately close the test jar with the cork carrying the high cloud and pour thermometer, or, if the expected pour point is above 36°C , the melting point thermometer. Adjust the position of the cork and thermometer so the cork fits tightly, the thermometer and the jar are coaxial, and the thermometer bulb

is immersed to a depth which places the beginning of the capillary 3 mm below the surface of the test specimen.

9.2.6 Proceed as described in 9.1.5-9.1.8.

10. Calculation and Report

10.1 Add 3°C to the temperature recorded in 9.1.8 and report as Maximum Pour Point, ASTM D5853, Procedure A, or Minimum Pour Point, ASTM D5853, Procedure B, if the procedure in 9.2 has been followed.

10.2 If the test was discontinued (9.1.8.1), report the pour point as $\leq -36^{\circ}\text{C}$.

11. Precision and Bias

11.1 The following criteria are to be used for judging the acceptability of results (95 % confidence):

11.1.1 *Repeatability*—The difference between successive test results obtained by the same operator with the same apparatus under constant operating conditions on identical test material would, in the long run, in the normal and correct operation of the test method, exceed the following value only in 1 case in 20.

Procedure	Repeatability $^{\circ}\text{C}$ (rounded)		
	A (max)	3.1	(3)
B (min)	5.8	(6)	(Note 9)

11.1.2 *Reproducibility*—The difference between two, single and independent results, obtained by different operators working in different laboratories on identical test material would, in the long run, in the normal and correct operation of the test method, exceed the following value only in 1 case in 20.

Procedure	Reproducibility $^{\circ}\text{C}$ (rounded)		
	A (max)	18.0	(18)
B (min)	22.0	(21)	(Note 9)

NOTE 9—These precision values are derived from a 1994 cooperative program⁶ and the current Committee D-2 Statistical Method, RR:D02-1007. A summary of the cooperative program and the relevant statistics is given in Appendix X2.

11.2 *Bias*—The procedure in this test method has no bias because the value of pour point is defined only in terms of this test method.

12. Keywords

12.1 cold flow; crude oil; pour point

⁶ The results of the cooperative test program from which these values have been derived are filed at ASTM Headquarters. Request RR:D02-1371.

APPENDIX

(Nonmandatory Information)

X1. GUIDELINE FOR SAMPLE HANDLING

X1.1 Introduction

X1.1.1 Sampling of crude oils from pipelines, tankers, barges, or trucks is usually beyond control of the laboratory and adequately covered by the appropriate sampling protocols as specified in Practices D 4057 and D 4177.

X1.1.2 This guideline covers the sampling from containers submitted to the analytical laboratory for analysis. It covers the handling of samples between the point at which they were extracted or drawn, and the laboratory test bench or sample storage. It is meant to ensure that the nature and integrity of the samples are maintained as far as possible.

X1.1.3 The method of handling a sample will depend on the purpose for which it was taken. The laboratory analytical procedure to be used will often require a special handling procedure to be associated with it. For this reason, consult the appropriate methods of test so that any necessary instructions as to sample handling can be given to the person drawing the sample. If the analytical procedures to be applied have conflicting requirements, as is often the case for crude oils, then draw separate samples and apply the appropriate procedure to each sample.

X1.1.4 For crude oils, care in sampling is particularly necessary because:

X1.1.4.1 They contain volatile material, hence loss by evaporation can occur.

X1.1.4.2 They contain water or sediment, or both, which tends to separate in the sample container.

X1.1.4.3 If not maintained at a sufficiently high temperature, wax deposition at the walls of the container or wax precipitation can occur.

X1.1.5 When making up composite samples, exercise care not to lose light ends and to ensure homogeneity of the composing samples.

X1.1.6 If crude oil samples are to be tested for vapor pressure, density, or any other test in which retention of light ends is essential, subsamples for these test methods shall be taken first before any other sample handling procedures are invoked for performing sampling for other tests such as pour point.

X1.1.7 Never subsample crude oils in plastic containers or any other container that will not retain gases or light materials and cannot be heated without deformation.

X1.2 Heating of Samples:

X1.2.1 Crude oils stored at temperatures below their cloud point will show wax deposition on the walls of the (sample) containers. The wax coming out of the solution will be preferentially the high melting wax. It is this type of wax that has the most pronounced influence on the crude oil pour point and, at the same time, is the most difficult to redissolve or disperse in the crude oil. Proper treatment of the samples before subsampling for pour point, therefore, is crucial for

obtaining reliable crude oil pour point results.

X1.2.2 In order to achieve complete solubility of the wax, heat crude oil samples to a temperature above the wax cloud point. This value is seldom known however. As a rule of thumb, a temperature of 20°C above the expected pour point will usually satisfy the cloud point requirement, although exceptions do occur.

X1.2.3 The vast majority of crude oils show a significant vapor pressure even at ambient temperatures. Dead crude is usually stabilized at a vapor pressure of 50 kPa (Test Method D 323, RVP at 37.8°C) or below. However, occasionally, high RVP crudes (80 kPa) are produced and marketed. Before testing, never subject a crude oil sample to a temperature higher than 60°C or to a temperature above the bubble point (vapor pressure ≥ 100 kPa). As a rule of thumb, the vapor pressure doubles for every 20°C increase in temperature.

X1.3 Homogenization of Samples:

X1.3.1 The proper means and effectiveness of mixing in order to achieve homogeneity depend, in addition to the physical properties (for example, viscosity) of the crude oil, on the capacity and shape of the container in which the crude oil arrives at the laboratory. It is virtually impossible to cater to every possibility and achieve optimum results under all circumstances. Guidelines are provided which in actual practice have proven to achieve the best possible results for the most common situations.

X1.3.2 Drums, 15 to 200 L:

X1.3.2.1 The most effective way of achieving homogenization is mixing the contents of the drum on a roller bank in a hot room kept at a temperature between 40 and 60°C for 48 h (X1.2.3). Alternatively, keep the drum at a temperature of 20°C above the expected pour point for 48 h (X1.2.3) and roll the drum for at least 15 min before taking a sample. If heating of the drum is not feasible, the only alternative is extensive rolling for at least 30 min to disperse the wax and wax particles as effectively as possible. In order to avoid the cumbersome procedure of (re)mixing the contents of large sample containers, it is recommended to draw an adequate number of subsamples in smaller containers, using Practice D 4057 as a guide (X1.1.3-X1.1.7) (**Warning**—Before embarking on any heating or mixing procedure, or both, ensure that the drum and plugs can withstand the expected pressure build-up and can be handled safely without leakage.) (**Warning**—Exercise care when opening the container as significant vapor pressure will have built up (X1.2.3). Opening the container may induce foaming with resultant spillage of sample and possible injury to personnel.)

X1.3.3 Tins, 1 to 15 L:

X1.3.3.1 Store the container at a temperature 20°C above the expected pour point (X1.2.1) preferably in a water bath kept at the appropriate temperature. Alternatively, store the container in an explosion-proof oven, bearing in mind that

local surface temperatures might be much higher than the oven temperature reading indicates. The time required to dissolve the wax will depend on the type of wax and the size of the container. For a 1 L tin, 2 h has been found to be adequate. For larger tins, longer times will be required. Although it is strongly recommended that the containers be closed when heated, it is advised that after approximately 30 min, the excess pressure is slowly released before continuing the heating. (**Warning**— Exercise care when opening the container as significant vapor pressure will have built up (X1.2.3). Opening the container may induce foaming with resultant spillage of sample and possible injury to personnel.) Mixing can be accomplished by a mechanical shaker or by vigorous manual shaking. Although the use of (high speed) mixers or similar devices might be effective, it will require that the container be open for some time, during which the escape of light ends can be excessive, and hence, this procedure is not recommended (**Warning**—During this operation significant amounts of highly flammable vapors might escape. Vent in a safe area.).

X1.3.4 Bottles:

X1.3.4.1 Follow as described in X1.3.3. Exercise special care when heating bottles that are closed with a cork or rubber stopper. The pressure build-up due to the heating will inevitably blow out the stopper. Take proper measures to safeguard against such an event (**Warning**—Before embarking on any heating or mixing procedure, or both, ensure that the drum and plugs can withstand the expected pressure build-up and can be handled safely without leakage.) (**Warning**—Exercise care when opening the container as significant vapor pressure will

have built up (X1.2.3). Opening the container may induce foaming with resultant spillage of sample and possible injury to personnel.).

X1.3.5 Plastic Containers:

X1.3.5.1 The use of plastic containers for crude oil samples is strongly discouraged for a number of reasons (X1.1.7). If such a container is offered to the laboratory, however, the only way to handle these containers is by heating to a temperature 20°C above the expected pour point (X1.2.1-X1.2.3) in a water bath kept at the appropriate temperature. The water bath prevents localized high temperatures in the container, which can create weak sections increasing the possibility of rupture. In any case, rupture of these containers due to pressure build-up is a distinct possibility and adequate measures must be taken to ensure safety (**Warning**—Exercise care when opening the container as significant vapor pressure will have built up (X1.2.3). Opening the container may induce foaming with resultant spillage of sample and possible injury to personnel.).

X1.3.6 Sample Receivers (Practice D 4177):

X1.3.6.1 Follow the prescribed sample mixing and handling procedure as described in Practice D 4177. It is recommended that a 1 L (tin) subsample be taken concurrently with subsampling for density and water and sediment, provided that the sample receiver has not been below the crude oil cloud point for more than 6 h. If the container has been kept at a temperature below the cloud point for more than 6 h, reheat the container to a temperature 20°C above the expected pour point (X1.2.1-X1.2.3) before mixing and subsampling.

The American Society for Testing and Materials takes no position respecting the validity of any patent rights asserted in connection with any item mentioned in this standard. Users of this standard are expressly advised that determination of the validity of any such patent rights, and the risk of infringement of such rights, are entirely their own responsibility.

This standard is subject to revision at any time by the responsible technical committee and must be reviewed every five years and if not revised, either reapproved or withdrawn. Your comments are invited either for revision of this standard or for additional standards and should be addressed to ASTM Headquarters. Your comments will receive careful consideration at a meeting of the responsible technical committee, which you may attend. If you feel that your comments have not received a fair hearing you should make your views known to the ASTM Committee on Standards, at the address shown below.

This standard is copyrighted by ASTM, 100 Barr Harbor Drive, PO Box C700, West Conshohocken, PA 19428-2959, United States. Individual reprints (single or multiple copies) of this standard may be obtained by contacting ASTM at the above address or at 610-832-9585 (phone), 610-832-9555 (fax), or service@astm.org (e-mail); or through the ASTM website (www.astm.org).