



Standard Practice for Sampling and Handling of Fuels for Volatility Measurement¹

This standard is issued under the fixed designation D 5842; the number immediately following the designation indicates the year of original adoption or, in the case of revision, the year of last revision. A number in parentheses indicates the year of last reapproval. A superscript epsilon (ϵ) indicates an editorial change since the last revision or reapproval.

1. Scope

1.1 This practice covers procedures and equipment for obtaining, mixing, and handling representative samples of volatile fuels for the purpose of testing for compliance with the standards set forth for volatility related measurements applicable to light fuels. The applicable dry vapor pressure equivalent range of this practice is 13 to 105 kPa (2 to 16 psia).

1.2 This practice is applicable to the sampling, mixing, and handling of reformulated fuels including those containing oxygenates.

1.3 The values stated in acceptable metric units are to be regarded as the standard except in some cases where drawings may show English measurements which are customary for that equipment.

1.4 *This standard does not purport to address all of the safety concerns, if any, associated with its use. It is the responsibility of the user of this standard to establish appropriate safety and health practices and determine the applicability of regulatory limitations prior to use.*

2. Referenced Documents

2.1 ASTM Standards:

D 323 Test Method for Vapor Pressure of Petroleum Products (Reid Method)²

D 4057 Practice for Manual Sampling of Petroleum and Petroleum Products³

D 4953 Test Method for Vapor Pressure of Gasoline and Gasoline-Oxygenate Blends (Dry Method)⁴

D 5190 Test Method for Vapor Pressure of Petroleum Products (Automatic Method)⁴

D 5191 Test Method for Vapor Pressure of Petroleum Products (Mini Method)⁴

2.2 API Documents:⁵

MPMS Chapter 8—Definitions

MPMS Chapter 8.1—Standard Practice for Manual Sampling of Petroleum and Petroleum Products

MPMS Chapter 8.2—Standard Practice for Automatic Sampling of Liquid Petroleum and Petroleum Products

MPMS Chapter 8.3—Standard Practice for Mixing and Handling of Liquid Samples of Petroleum and Petroleum Products

3. Terminology

3.1 Definitions of Terms Specific to This Standard:

3.1.1 *bottom sample*—a sample obtained from the material at the bottom of the tank, container, or line at its lowest point.

3.1.1.1 *Discussion*—In practice the term bottom sample has a variety of meanings. As a result, it is recommended that the exact sampling location (for example, 15 cm [6 in.] from the bottom) should be specified when using this term.

3.1.2 *dead legs*—sections of pipe that, by design, do not allow for the flow of material through them.

3.1.2.1 *Discussion*—Dead legs are not suitable for obtaining representative samples.

3.1.3 *relief lines*—sections of pipe that lead to a pressure/vacuum relief valve.

3.1.3.1 *Discussion*—Relief lines are not suitable for obtaining representative samples.

3.1.4 *stand pipes*—vertical sections of pipe or tubing extending from the gaging platform to near the bottom of tanks that are equipped with external or internal floating roofs. Stand pipes also may be found on ships and barges.

3.1.4.1 *Discussion*—Stand pipes which are not slotted or perforated will not yield representative samples. Further information on proper stand pipe design is given in 6.4.3.

3.1.5 Other sample definitions are given in Practice D 4057.

4. Summary of Practice

4.1 It is necessary that the samples be representative of the fuel in question. The basic principle of each sampling procedure involves obtaining a sample in such a manner and from

¹ This practice is under the jurisdiction of ASTM Committee D-2 on Petroleum Products and Lubricants and is the direct responsibility of Subcommittee D02.02 on Static Petroleum Measurement.

Current edition approved Nov. 10, 1995. Published February 1996.

² *Annual Book of ASTM Standards*, Vol 05.01.

³ *Annual Book of ASTM Standards*, Vol 05.02.

⁴ *Annual Book of ASTM Standards*, Vol 05.03.

⁵ Available from the American Petroleum Institute, 1220 L St., NW, Washington, DC 20005.

such locations in the tank or other container that the sample will be representative of the fuel. A summary of the sampling procedures and their application is presented in Table 1. Each procedure is suitable for sampling a material under definite storage, transportation, or container conditions. The precautions required to ensure the representative character of the samples are numerous and depend upon the tank, carrier, container, or line from which the sample is being obtained, the type and cleanliness of the sample container, and the sampling procedure that is to be used.

5. Significance and Use

5.1 The dry vapor pressure equivalent (DVPE) of volatile motor fuels is regulated by federal and state air pollution control agencies. In order to meet the letter of these regulations, it is necessary to sample, handle, and test these products in a very precise manner.

6. General Comments

6.1 Sample Containers:

6.1.1 Sample containers are clear or brown glass bottles, fluorinated high-density polyethylene bottles, or metal cans. The clear glass bottle is advantageous because it is easily examined visually for cleanliness, and also makes visual inspection of the sample for free water or solid impurities possible. The brown glass bottle affords some protection from light. The only cans acceptable are those with the seams soldered on the exterior surface.

6.1.2 Cork stoppers, or screw caps of plastic or metal, are used for glass bottles; screw caps with inserted seals only are used for cans to provide a vapor-tight closure seal. Corks must be of good quality, clean, and free from holes and loose bits of cork. Never use rubber stoppers. Contact of the sample with the cork can be prevented by wrapping tin or aluminum foil around the cork before forcing it into the bottle. Screw caps must be protected by a cork disk faced with tin or aluminum foil, an inverted cone polyseal or other material that will not affect petroleum or petroleum products. The fluorinated bottles are supplied with polypropylene screw caps.

6.1.3 Sample size is dictated by the test method to be used. One litre (32 oz) bottles or cans are generally used for manual vapor pressure testing. The mini-vapor pressure methods need

a much smaller sample and it can be taken in a 125 mL (4 oz) bottle. See Fig. 1.

6.1.4 All sample containers must be absolutely clean and free of foreign matter. Before reusing a container, wash it with strong soap solution, rinse it thoroughly with tap water, and finally with distilled water. Dry completely, stopper, or cap the container immediately.

6.2 *Sampling Apparatus*—Sampling apparatus is described in detail under each of the specific sampling procedures. Clean, dry, and free all sampling apparatus from any substance that might contaminate the material. If necessary, use the clean procedure described in 6.4.

6.3 Time and Place of Sampling:

6.3.1 *Storage Tanks*—When loading or discharging fuels, take samples from both shipping and receiving tanks, and from the pipelines if required.

6.3.2 *Ship or Barge Tanks*—Sample each product after the vessel is loaded or just before unloading.

6.3.3 *Tank Cars*—Sample the product after the car is loaded or just before unloading.

NOTE 1—Time, place, and other details of sampling not covered in this practice are normally determined by contractual agreement or regulatory requirements.

6.4 Obtaining Samples:

6.4.1 Directions for sampling cannot be made explicit enough to cover all cases. Extreme care and good judgment are necessary to ensure samples that represent the general character and average condition of the material. Use lint-free wiping cloths to prevent contaminating samples.

6.4.2 Many petroleum vapors are toxic and flammable. Avoid breathing them or igniting them from an open flame or a spark. Follow all safety precautions specific to the material being sampled.

6.4.3 Do not sample dead legs or relief lines. Do not sample stand pipes that are not slotted or perforated! Fig. 2 is an example of an adequately slotted stand pipe. At a minimum, the stand pipe should have two rows of slots slightly staggered in the vertical plane.

6.4.4 Rinse or flush sample containers with product and allow it to drain before drawing the sample. If the sample is to be transferred to another container (for testing other than DVPE), the sampling apparatus also is rinsed with some of the product and drained. When the sample is emptied into this container, upend the sampling apparatus into the opening of the sample container.

6.5 Handling Samples:

6.5.1 Protect all samples of light fuels from evaporation. The sampling apparatus is the sample container for vapor pressure. Keep the container tightly closed after the sample is collected. Leaking sample containers are not suitable for testing. Cool volatile samples to 0 to 1°C (32 to 34°F) after delivery to the laboratory and before opening the container. Maintain at this temperature throughout transfer and handling, if at all possible.

6.5.2 Never completely fill a sample container. Fill the container to 70 to 85 % capacity to allow adequate room for expansion. Subsequent testing for vapor pressure requires this level of container fill.

TABLE 1 Summary of Gasoline Sampling Procedures and Applicability

Type of Container	Procedure	Paragraph
Storage tanks, ship and barge tanks, tank cars, tank trucks	all-levels sampling	7.2.1.2
	running sample	7.2.1.2
	upper, middle and lower samples	7.2.1.2
	top sample	7.2.1.2
	grab sampling	7.5
Storage tanks with taps	tap sampling	7.2.2
	line sampling	7.3
Pipes and lines	automatic sampling	7.4
	time proportional	7.4.1
	flow proportional	7.4.2
	grab sampling	7.5
	nozzle sampling	7.6
Retail outlet and wholesale purchaser-consumer facility storage tanks		

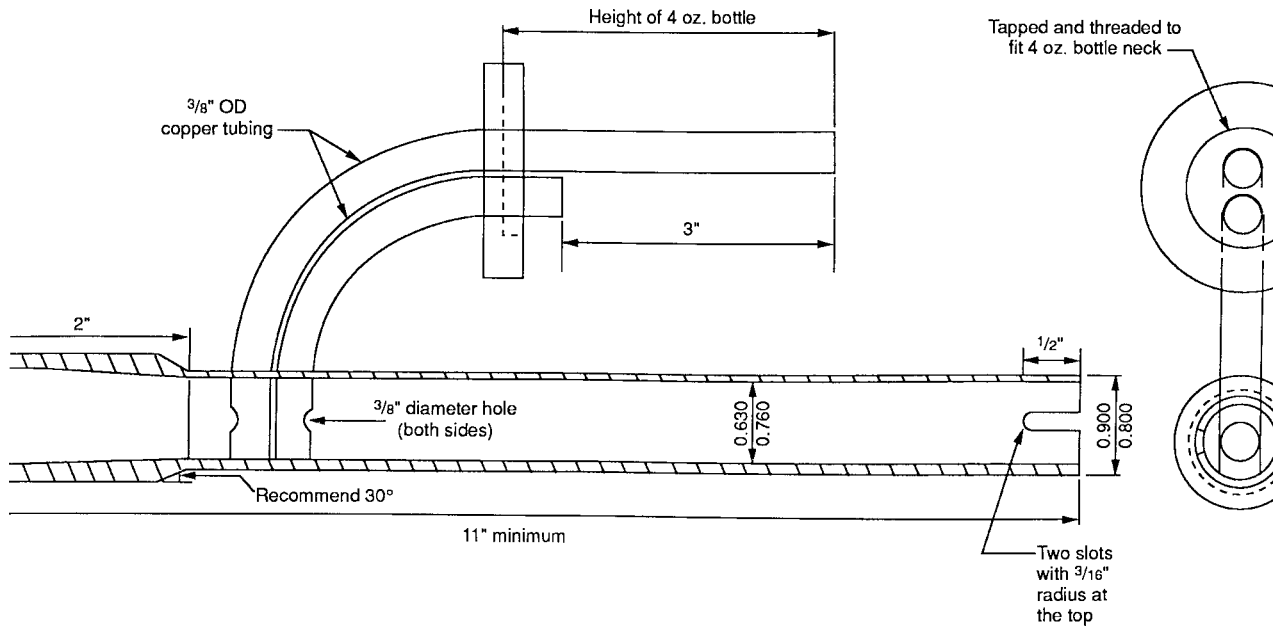

NOTE 1—All dimensions are in inches.
 NOTE 2—All decimal dimensions represent minimum and maximum.
 NOTE 3—Tolerance for all other dimensions is $\pm 1/32$ in.
 NOTE 4—Made of non-ferrous material, unaffected by gasoline.
 Scale—0.700 in. = 1 in.

FIG. 1 Nozzle Extension for Nozzle Sampling with 4 oz Bottle

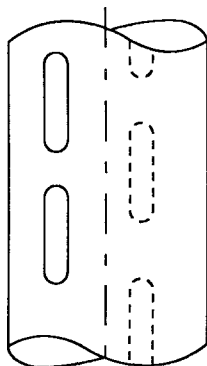

FIG. 2 Slotted Stand Pipe

6.5.3 The first sample aliquot removed is for vapor pressure testing. The remaining sample in the container is not suitable for a vapor pressure determination but is suitable for other testing.

6.6 *Shipping Samples*—To prevent loss of liquid and vapors during shipment, place internal seals in the metal containers, screw the caps down tightly and check for leakage. Observe all shipping regulations applying to the transportation of flammable liquids.

6.7 *Labeling Sample Containers*—Label the container immediately after a sample is obtained. Use waterproof and oilproof ink or a pencil hard enough to dent the tag, since soft pencil and ordinary ink markings are subject to obliteration from moisture, product, smearing, and handling. Typical label information includes the following information:

6.7.1 Date and time (the period elapsed during continuous sampling),

- 6.7.2 Name of the sample (location),
- 6.7.3 Name or number and owner of the vessel, car, or container,
- 6.7.4 Brand and grade of material; and
- 6.7.5 Reference symbol or identification number.
- 6.7.6 Labeling should conform to all applicable federal, state, and local labeling regulations.

7. Specific Sampling Procedures

7.1 *Sampling Procedures*—The standard sampling procedures described in this practice are summarized in Table 1. Alternative sampling procedures can be used if a mutually satisfactory agreement has been reached by the party(ies) involved and such agreement has been put in writing and signed by authorized officials.

7.2 Tank Sampling:

7.2.1 *Bottle Sampling*—The bottle sampling procedure is applicable for sampling fuels of 105 kPa (16 psia) Reid equivalent vapor pressure or less in tank cars, tank trucks, shore tanks, ship tanks, and barge tanks.

7.2.1.1 *Apparatus*—A suitable sampling bottle as shown in Fig. 3 is required. Recommended diameter of the opening in the bottle or sample thief is 19 mm ($3/4$ in.).

7.2.1.2 Procedure:

(a) *All-levels Sample*—Lower the weighted, stoppered bottle (see Fig. 3) as near as possible to the draw-off level, pull out the stopper with a sharp jerk of the cord or chain and raise the bottle at a rate so that it is 70 to 85 % full as it emerges from the liquid.

(b) *Running Sample*—Lower the stoppered container (with a hole or slot in the stopper) at a uniform rate as near as

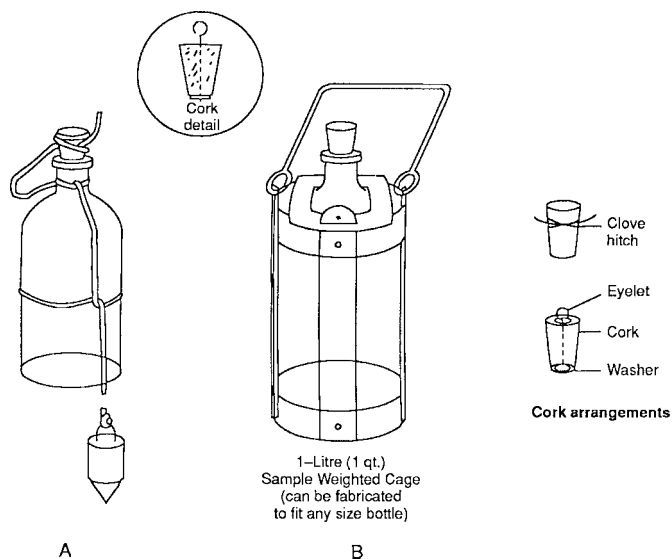

FIG. 3 Assembly for Bottle Sampling

possible to the level of the bottom of the outlet connection or swing line and immediately raise the bottle to the top of the fuel at a rate of speed such that it is 70 to 85 % full when withdrawn from the liquid.

NOTE 2—Running or all-level samples are not necessarily representative because the tank volume may not be proportional to the depth and because the operator may not be able to raise the sampler at the required rate.

(c) *Upper, Middle, and Lower Samples*—Lower the weighted, stoppered bottle to the proper depths (Fig. 4) as follows:

upper sample	middle of upper third of the tank contents
middle sample	middle of the tank contents
lower sample	middle of the lower third of the tank contents

At the selected level, pull out the stopper with a sharp jerk of the cord or chain and allow the bottle to fill completely, as evidenced by the cessation of air bubbles. When full, raise the bottle, pour off a small amount (15 to 30 %), and stopper immediately.

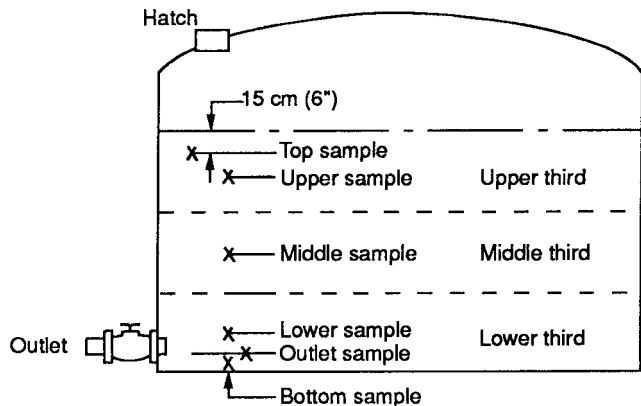

NOTE 1—The outlet sample location shown applies only to tanks with side outlets. It does not apply when the outlet comes from the floor of the tank or turns down into a sump.

FIG. 4 Tank Sampling Depths

(d) *Top Sample*—Obtain this sample (Fig. 4) in the same manner as specified for an upper sample but at 150 mm (6 in.) below the top surface of the tank contents.

(e) *Handling*—Cap and label bottle samples immediately after taking them, and deliver to the laboratory in the original sampling bottles. Multiple samples must be tested individually for vapor pressure. A composite sample is acceptable for other analytical tests. Inverting the sample container can aid in leak detection. Sample may be placed in ice immediately for cooling if practical (see Section 10).

7.2.2 *Tap Sampling*—The tap sampling procedure is applicable for sampling liquids of 105 kPa (16 psia) DVPE, or less, in tanks that are equipped with suitable sampling taps or lines. This procedure is recommended for volatile stocks in tanks of the breather and balloon roof type, spheroids, floating roof tanks, and so forth. The assembly for tap sampling is shown in Fig. 5.

7.2.2.1 *Apparatus:*

(a) (a) *Tank Taps*—Equip the tank with at least three sampling taps placed equidistant throughout the tank height. A standard 1/4 in. pipe with a suitable valve is satisfactory. A sufficient number of sample taps are needed on the tank to make sampling possible at various levels.

(b) (b) *Tube*—Use a delivery tube that will not contaminate the product being sampled and is long enough to reach to the bottom of the sample container to allow submerged filling.

(c) (c) *Tube Chiller Assembly (Optional)*—If a sampling chiller is used, it is a coil of tubing immersed in an ice bath to chill a fuel sample as it is dispensed into the sample container.

(d) (d) *Sample Containers*—Use clean, dry glass bottles of convenient size and strength or metal containers to receive the samples.

7.2.2.2 *Procedure*—Before a sample is drawn, flush the sample tap and tube until approximately three times its volume has been purged. When sampling for Reid equivalent vapor pressure, the container must be chilled to a temperature as low as the material in the tank or to 0°C (32°F), whichever is greater (see sample chilling apparatus in Fig. 6). Filling the container and emptying it three times will meet this temperature requirement. Draw upper, middle, or lower samples directly from the respective taps after the flushing operation. Stopper or seal and cap, label the sample container immediately after filling and deliver it to the laboratory.

7.3 *Line Sampling*—The continuous sampling procedure is applicable for sampling liquids of 105 kPa (16 psia) Reid equivalent vapor pressure or less and semi-liquids in pipelines, filling lines, and transfer lines. The line sampling may be done manually or by using automatic devices. In order to take a representative sample from a line, the contents are mixed to ensure uniform distribution of all components and contaminants across the line. If it is necessary to condition the line, this is done four to six pipe diameters upstream of the sample point.

7.3.1 *Apparatus:*

7.3.1.1 *Sampling Probe*—The function of the sampling probe is to allow withdrawal of a representative portion of liquids. The apparatus assembly for dynamic line sampling is shown in Fig. 7. A probe is recommended for the sampling of static systems but it is not required. Probe designs that are

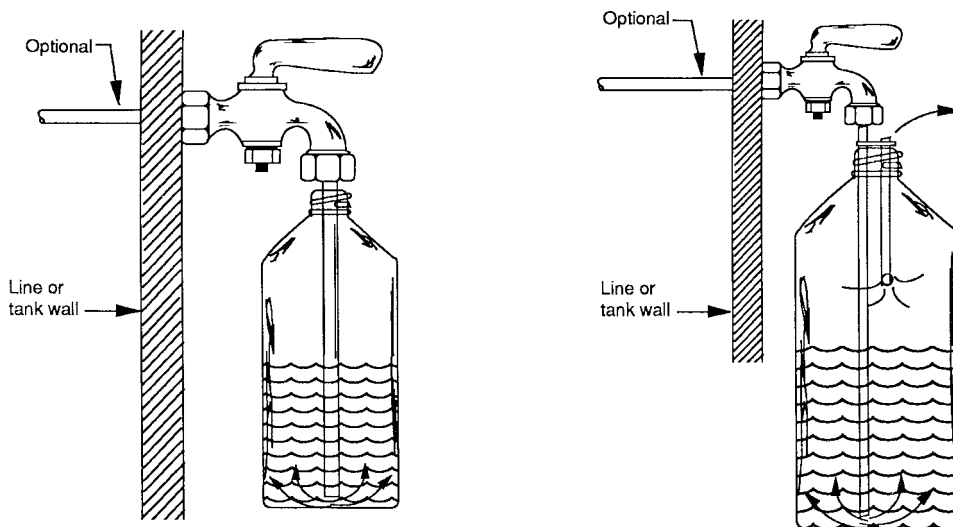

NOTE 1—Probes are optional.
FIG. 5 Assemblies for Tap Sampling

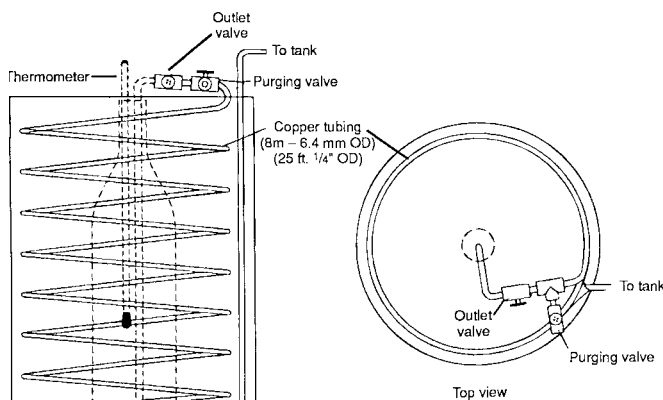

FIG. 6 Cooling Bath for Reid Equivalent Vapor Pressure Sampling

commonly used are as follows:

- (a) (a) A tube beveled at a 45° angle (Fig. 7a).
- (b) (b) A long-radius forged elbow or pipe bend with the end of the probe reamed to give a sharp entrance edge (Fig. 7b).
- (c) (c) A closed-end tube with a round orifice spaced near the closed end (Fig. 7c).

7.3.1.2 *Probe Location*—The probe inlet is extended into the pipe to the center one-third of the pipeline cross-sectional area. The probe is inserted perpendicular to the direction of flow with the sample opening facing upstream. The sampling lines are kept as short as practicable and purged completely before any samples are taken.

7.3.1.3 *Valves*—To control the rate at which the sample is withdrawn, the probe or probes are fitted with ball, gate, needle, or large port valves.

7.4 *Automatic Samplers*—An automatic sampler includes not only the automatic sampling device that extracts the samples from the line, but also a suitable probe, connecting lines, auxiliary equipment, and a container in which the sample is collected. It must maintain sample integrity. Refer to API

MPMS Chapter 8.2. Automatic samplers are classified as follows:

7.4.1 *Continuous Sampler, Time Cycle (Nonproportional) Type*—A sampler designed so that it transfers equal increments of liquid from the pipeline to the sample container at uniform time increments.

7.4.2 *Continuous Sampler, Flow-Responsive (Proportional) Type*—A sampler designed to automatically adjust the sampling rate to be proportional to the flow rate of the stream.

7.4.3 *Calibration*—Prior to initial operation, the sample bite size must be verified to be within $\pm 5\%$ of the specification using an acceptable calibration procedure. Additionally, the required sample volume must be obtained during any sampling period so that the manufacturer's sampling interval is not exceeded.

7.4.4 *Container*—The container must be a clean, dry container of convenient size to receive the sample. All connections from the sample probe to the sample container must be free of leaks. The container is constructed in such a manner that it prevents evaporation loss. The construction must allow cleaning, interior inspection, and complete mixing of the sample prior to removal. A fixed volume type container is equipped with a pressure-relief device.

7.5 *Grab or Spot Sampling*—Purge approximately three volumes of product through the sample tap and tubine. Divert the sample stream to the sampling container to provide a quantity of sample that will be of sufficient size for analysis.

7.6 *Nozzle Sampling*—The nozzle sampling procedure is applicable for sampling light fuels from a retail type dispenser.

7.6.1 *Apparatus*—Sample containers conforming with Section 6 should be used. A spacer, if appropriate, and a nozzle extension as shown in Fig. 8 and Fig. 9 are used when nozzle sampling.

7.6.2 *Procedure*—Immediately after fuel has been delivered from the pump and the pump has been reset, attach a spacer (Fig. 8), if needed, to the pump nozzle (vapor recovery type). Insert nozzle extension (Fig. 9) into the previously chilled sample container and insert the pump nozzle into the extension

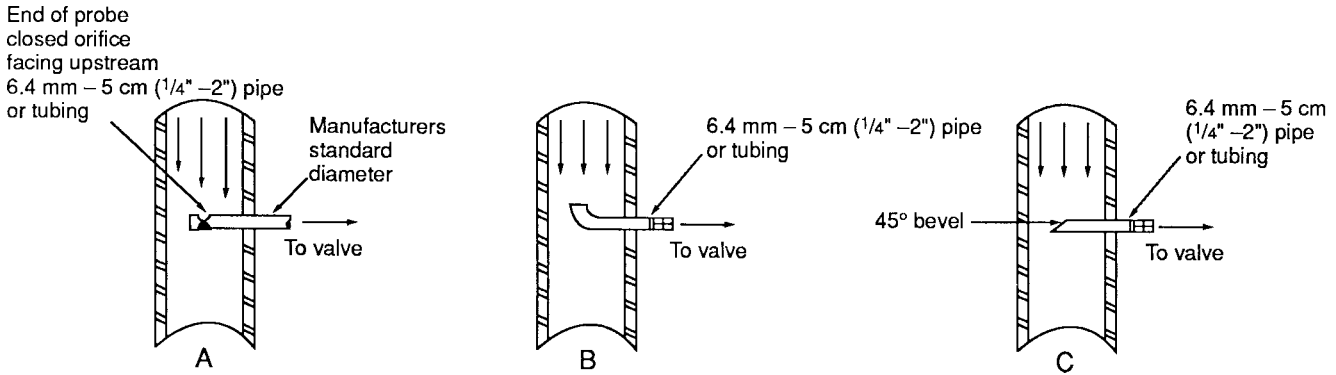
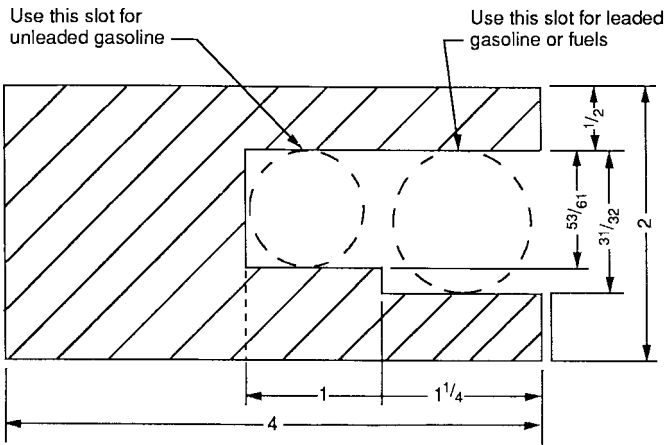

FIG. 7 Probes for Line Sampling



NOTE 1—Make from 1/4 in. flat non-ferrous metal.
 NOTE 2—All dimensions are in inches.
 NOTE 3—Break all edges and corners.

FIG. 8 Spacer for Nozzle Sampling

8. Special Precautions and Instructions

8.1 *Precautions*—Vapor pressures are extremely sensitive to evaporation losses and to slight changes in composition. When obtaining, storing, or handling samples, observe the necessary precautions to ensure the samples are representative of the product and satisfactory for Reid equivalent vapor pressure tests. Never manually prepare composite samples for this test. Make certain that containers that are to be shipped by common carrier conform to applicable federal, state, and local regulations. When flushing or purging lines or containers, observe the pertinent regulations and precautions against fire, explosion, and other hazards. Collect all line flushes and bottle rinses for proper recovery or disposal.

8.2 *Sample Containers*—Use containers of sufficient strength to withstand the pressures to which they can be subjected, and of a type that will permit replacement of the cap or stopper with suitable connections for transferring the sample to the gasoline chamber of the vapor pressure apparatus.

9. Keywords

9.1 dry vapor pressure; fuels; gasoline; gasoline sampling; petroleum products; sampling; sample handling; sampling of volatile products; vapor pressure; volatility

with slot over the air bleed hole. Fill the sample container slowly through the nozzle extension to 70 to 85 % full (Fig. 10). Remove the nozzle extension. Insert the seal and cap or stopper into the sample container at once. Check for leaks. If a leak occurs, discard the sample container and resample. If the sample container is leak tight, label the container and deliver it to the laboratory.

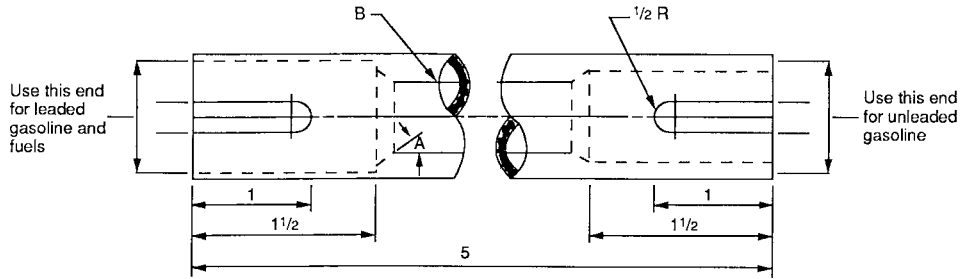

NOTE 1—Use $\frac{3}{4}$ in. Schedule 80 non-ferrous pipe.

NOTE 2—All dimensions are in inches.

NOTE 3—All tolerances are $\pm \frac{1}{120}$.

^A Recommend 30° .

^B Inside diameter schedule 80 non-ferrous pipe.

FIG. 9 Extension for Nozzle Sampling

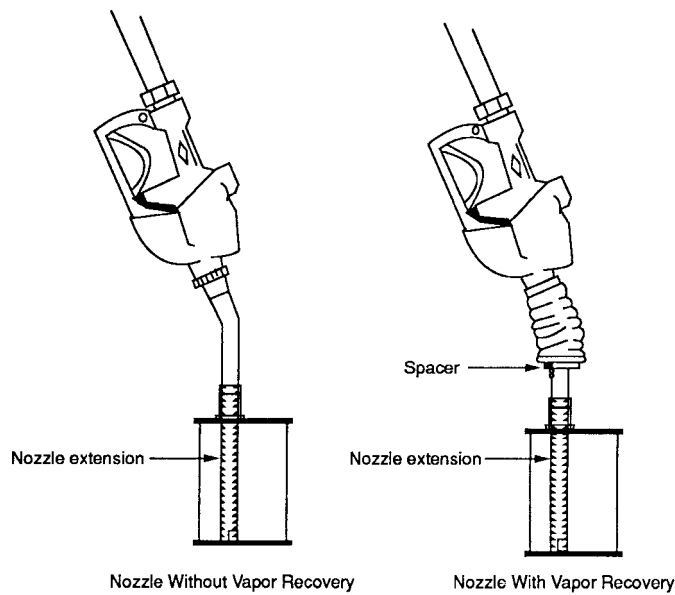

FIG. 10 Assembly for Nozzle Sampling

ASTM International takes no position respecting the validity of any patent rights asserted in connection with any item mentioned in this standard. Users of this standard are expressly advised that determination of the validity of any such patent rights, and the risk of infringement of such rights, are entirely their own responsibility.

This standard is subject to revision at any time by the responsible technical committee and must be reviewed every five years and if not revised, either reapproved or withdrawn. Your comments are invited either for revision of this standard or for additional standards and should be addressed to ASTM International Headquarters. Your comments will receive careful consideration at a meeting of the responsible technical committee, which you may attend. If you feel that your comments have not received a fair hearing you should make your views known to the ASTM Committee on Standards, at the address shown below.

This standard is copyrighted by ASTM International, 100 Barr Harbor Drive, PO Box C700, West Conshohocken, PA 19428-2959, United States. Individual reprints (single or multiple copies) of this standard may be obtained by contacting ASTM at the above address or at 610-832-9585 (phone), 610-832-9555 (fax), or service@astm.org (e-mail); or through the ASTM website (www.astm.org).