



Standard Test Method for Cloud Point of Petroleum Products (Linear Cooling Rate Method)¹

This standard is issued under the fixed designation D 5772; the number immediately following the designation indicates the year of original adoption or, in the case of revision, the year of last revision. A number in parentheses indicates the year of last reappraisal. A superscript epsilon (ϵ) indicates an editorial change since the last revision or reappraisal.

INTRODUCTION

This test method describes an alternative procedure for the determination of cloud point of petroleum products of Test Method D 2500/IP219 using an automatic apparatus. The temperature results from this test method have been found to be equivalent to Test Method D 2500/IP219. When specification requires Test Method D 2500/IP219, do not substitute this test method or any other method without obtaining comparative data and agreement from the specifier.

1. Scope*

1.1 This test method describes the determination of the cloud point of petroleum products and biodiesel fuels that are transparent in layers 40 mm in thickness by an automatic instrument using a linear cooling rate.

1.2 This test method covers the range of temperatures from -60 to 49°C with temperature resolution of 0.1°C , however, the range of temperatures included in the 1997 interlaboratory cooperative test program only covered the temperature range of -56 to $+34^{\circ}\text{C}$.

1.3 The values stated in SI units are to be regarded as the standard. The values given in parentheses are for information only.

1.4 *This standard does not purport to address all of the safety concerns, if any, associated with its use. It is the responsibility of the user of this standard to establish appropriate safety and health practices and determine the applicability of regulatory limitations prior to use.*

2. Referenced Documents

2.1 ASTM Standards:

D 2500 Test Method for Cloud Point of Petroleum Products²

D 4057 Practice for Manual Sampling of Petroleum and Petroleum Products³

D 4177 Practice for Automatic Sampling of Petroleum and Petroleum Products³

2.2 IP Standard:

IP219 Test Method for Cloud Point of Petroleum Products⁴

3. Terminology

3.1 Definitions:

3.1.1 *biodiesel, n*—a fuel comprised of mono-alkyl esters of long-chain fatty acids derived from vegetable oils or animal fats, designated B100.

3.1.1.1 *Discussion*—Biodiesel is typically produced by a reaction of vegetable oil or animal fat with an alcohol such as methanol or ethanol in the presence of a catalyst to yield mono-esters and glycerin. The fuel typically may contain up to 14 different types of fatty acids that are chemically transformed into fatty acid methyl esters (FAME).

3.1.2 *biodiesel blend, n*—a blend of biodiesel fuel with petroleum-based diesel fuel designated BXX, where XX is the volume percentage of biodiesel.

3.1.3 *cloud point, n*—in petroleum products and biodiesel fuels, the temperature of a liquid specimen when a wax crystal structure that is similar in appearance to a cloud is formed upon cooling under prescribed conditions.

3.1.3.1 *Discussion*—The cloud point appears when the temperature of the specimen is low enough to cause wax crystals to precipitate. In homogeneous liquids, the cloud is always noted first at the location in the specimen where the specimen temperature is the lowest. This is typically at the lower portion of the test jar when using the apparatus described in Test Method D 2500.

¹ This test method is under the jurisdiction of ASTM Committee D02 on Petroleum Products and Lubricants and is the direct responsibility of Subcommittee D02.07 on Flow Properties.

Current edition approved July 10, 2003. Published August 2003. Originally approved in 1995. Last previous edition approved in 2002 as D 5772-02.

² *Annual Book of ASTM Standards*, Vol 05.01.

³ *Annual Book of ASTM Standards*, Vol 05.02.

⁴ Available from the Institute of Petroleum, 61 New Cavendish St., London, England W1M 8AR.

*A Summary of Changes section appears at the end of this standard.

3.2 Definitions of Terms Specific to This Standard:

3.2.1 *automatic cloud point, n*—the temperature of a specimen when the appearance of the cloud is determined under the conditions of this test method.

3.2.1.1 *Discussion*—The cloud point in this test method is determined by an automatic instrument using an optical device for detection of the crystal formation. The apparatus and the conditions are different from those established for Test Method D 2500, although, according to interlaboratory examination, the results have been determined to be equivalent to Test Method D 2500.

3.2.2 *D 2500/IP219 equivalent cloud point, n*—the temperature of a specimen, in integers, calculated by rounding the results of this test method to the next lower integer.

3.2.2.1 *Discussion*—This test method produces results with 0.1°C resolution. Should the user wish to provide results with a similar format to Test Method D 2500, then this calculation can be performed. Some apparatus can perform this calculation automatically.

4. Summary of Test Method

4.1 After insertion of the specimen into the apparatus and initiation of the program, the specimen is heated and then cooled at a specified rate. The specimen is continuously monitored by an optical light barrier for the crystal structure formation. The temperature, when the crystallization of the wax in the specimen is detected by the optical barrier, is recorded with a resolution of 0.1°C. The specimen is then heated to the original starting temperature.

5. Significance and Use

5.1 For petroleum products and diesel fuels, the cloud point is an index of the lowest temperature of its utility for certain applications. Wax crystals of sufficient quantity can plug filters used in some fuel systems.

5.2 Petroleum blending operations require precise measurement of the cloud point.

5.3 This test method can determine the temperature of the test specimen at which wax crystals have formed sufficiently to be observed as a cloud, with a resolution of 0.1°C.

5.4 This test method provides results that when rounded to the next lower integer are equivalent to Test Method D 2500.

5.5 This test method is more precise than Test Method D 2500.

6. Apparatus

6.1 *Automatic Apparatus*⁵—The automatic cloud point apparatus described in Annex A1 consists of a microprocessor-controlled measuring unit that is capable of heating, cooling, optically observing the appearance of the automatic cloud point, and recording the temperature of the specimen. The apparatus shall be equipped with a digital display, cooling/heating block assembly, optical light barrier assembly, and a

test cell of the approximate dimensions listed in Annex A1, and contain a temperature measuring device.

6.2 *Beaker*, glass or plastic (disposable) (50 mL), for containing the sample prior to introduction into the test cell.

6.3 *Circulating Bath*, a refrigeration unit equipped with a circulating pump capable of maintaining a temperature at least 20°C lower than the lowest expected cloud point to be measured.

7. Reagents and Materials

7.1 *Cleaning Solvents*, suitable for cleaning and drying the test cell, such as petroleum naphtha and acetone. (**Warning**—Flammable. Liquid causes eye burns. Vapor is harmful. May be fatal or cause blindness if swallowed or inhaled.)

7.2 *Methyl Alcohol*, anhydrous, for use as cooling medium in circulating bath.

8. Sampling

8.1 Obtain a sample in accordance with Practices D 4057 or D 4177.

8.2 Samples of very viscous materials may be warmed until they are reasonably fluid before they are sampled. However, no sample should be heated more than absolutely necessary.

8.3 The sample shall not be heated above 70°C. When the sample is heated above 70°C, allow the sample to cool below 70°C before filtering or inserting into the apparatus.

8.4 When moisture is present in the sample, remove the moisture by a method such as filtration through dry lint-free filter paper until the oil is perfectly clear. Make such filtration at a temperature at least 14°C above the expected cloud point.

NOTE 1—Moisture will be noticed in the sample as a separate phase or as a haze throughout the entire sample. Generally, a slight haze will not interfere with the detection of the wax cloud.

9. Preparation of Apparatus

9.1 Prepare the instrument for operation in accordance with the manufacturer's instructions.

9.2 Clean and dry the test cell using suitable solvents as prescribed by the manufacturer.

9.3 Prepare the refrigerated circulating bath for operation in accordance with the manufacturer's instructions and allow it to attain a temperature at least 20°C lower than the expected cloud point of the sample.

10. Calibration and Standardization

10.1 Ensure that all of the manufacturer's instructions for calibrating, checking, and operating the apparatus are followed.

10.2 A sample with a mutually agreed upon cloud point can be used to verify performance of the apparatus.

11. Procedure

11.1 Pour at least 20 mL of the sample into the beaker. When necessary, heat the sample in a water bath or oven until it is just sufficiently fluid to pour into the beaker.

11.2 Place the beaker under the entrance of the test cell and start the test in accordance with the manufacturer's instructions.

⁵ The sole source of supply of the Herzog Model SC 815 and SC 819 known to the committee at this time is Walter Herzog, Lauda, Germany. If you are aware of alternative suppliers, please provide this information to ASTM International Headquarters. Your comments will receive careful consideration at a meeting of the responsible technical committee¹, which you may attend.

11.3 When the expected cloud point is known to be above 25°C, preselect a starting temperature which is at least 14°C above the expected cloud point. The highest starting temperature that can be programmed is 70°C.

11.4 When the expected cloud point is known to be at or below 25°C, the test duration can be shortened by preselecting a starting temperature which is at least 14°C above the expected cloud point. The lowest starting temperature that can be programmed is 20°C.

11.5 When the expected cloud point is not known, preselect a starting temperature of 40°C. The apparatus automatically heats the test specimen to approximately 40°C when a starting temperature is not selected. When the expected cloud point is not known and the sample needs to be heated before transferring into the test specimen beaker, preselect a starting temperature of 70°C.

11.6 A portion of the sample is drawn into the test cell. Initially, the specimen is heated to 40°C or to a starting temperature preselected by the operator between 20 and 70°C. The flow of the cooling fluid from the circulating bath is then regulated to maintain the rate of cooling of the specimen at $1 \pm 0.2^\circ\text{C}$ per min (see Note 2). The specimen is continuously monitored by the optical light barrier and the specimen temperature is continuously displayed. At the detection of the automatic cloud point, the temperature the specimen attained, to within 0.1°C resolution, is held on the digital display until cleared by the operator. The specimen is then heated to 40°C or to the preselected starting temperature.

NOTE 2—Although the apparatus is capable of faster cooling rates of 2 or 3°C/min, the interlaboratory program does not address the equivalency and precision of results using these cooling rates.

11.7 Clean the test cell by flushing solvents through the cell and then dry with clean air according to the manufacturer's instructions.

NOTE 3—Some apparatus is capable of automatic cleaning of the test cell and automatic sample changing.

12. Report

12.1 Report the temperature recorded in 11.6 as the automatic cloud point Test Method D 5772.

12.2 When specified, round the temperature recorded in 11.6 to the next lower integer and report as the D 2500 equivalent cloud point in accordance with Test Method D 5772.

13. Precision and Bias

13.1 *Precision*—The precision of this test method as determined by the statistical examination of the interlaboratory test results^{6,7} is as follows:

13.1.1 *Repeatability*—The difference between successive test results obtained by the same operator using the same

apparatus under constant operating conditions on identical test material would in the long run, in the normal and correct operation of this test method, exceed 1.3°C only in one case in twenty.

13.1.2 *Reproducibility*—The difference between two single and independent test results obtained by different operators working in different laboratories on identical test material would in the long run, in the normal and correct operation of this test method, exceed 3.3°C only in one case in twenty.

13.1.3 The precision statements were derived from a 1997 interlaboratory cooperative test program.⁷ Participants analyzed eleven sample sets, as blind duplicates, comprised of various distillate fuels and lubricating oils with a temperature range from +34 to -56°C. Five laboratories participated with the automatic apparatus and eight laboratories participated with the manual Test Method D 2500/IP219 test method. Information on the type of samples and their average cloud points are in the research report.⁶

13.2 *Bias*—Since there is no accepted reference material suitable for determining the bias for the procedure in this test method, bias has not been determined.

13.3 *Relative Bias*—The results of the interlaboratory program were examined for bias relative to Test Method D 2500/IP219. Although statistically significant bias was observed, the magnitude was determined to be small enough (-0.67°C) to be of little practical significance.

13.4 *Precision for Biodiesel Products*—The precision of this test method, as determined by the statistical examination of the interlaboratory test results, is as follows:

13.4.1 *Repeatability for Biodiesel in Diesel Blends*—The difference between successive test results, obtained by the same operator using the same apparatus under constant operating conditions on identical test material, would, in the long run, in the normal and correct operation of this test method, exceed 0.7°C only in one case in twenty.

13.4.2 *Reproducibility for Biodiesel in Diesel Blends*—The difference between two single and independent test results, obtained by different operators working in different laboratories on identical test material, would in the long run, in normal and correct operation of this test method, exceed 2.2°C only in one case in twenty.

NOTE 4—The precision for blends of biodiesel in diesel samples comprised cloud points from about -2 to + 10°C.

13.4.3 The precision statements were derived from a 2001 interlaboratory cooperative test program.⁸ Participants analyzed eleven sample sets comprised of two petroleum distillate fuels, diesel and kerosine, with various biodiesel fuels with a temperature range from +10 to -45°C. Five laboratories participated with the automatic machines and ten laboratories participated with the manual Test Method D 2500/IP219. Information on the type of samples and their average cloud points are in the research report.

NOTE 5—One of the outcomes of the interlaboratory study was the

⁶ Supporting data (the results of the 1990 interlaboratory cooperative test program) have been filed at ASTM International Headquarters and may be obtained by requesting Research Report RR: D02-1373.

⁷ Supporting data (the results of the 1997 interlaboratory cooperative test program) have been filed at ASTM International Headquarters and may be obtained by requesting Research Report RR: D02-1509.

⁸ Supporting data (the results of the 2001 interlaboratory cooperative test program) have been filed at ASTM International Headquarters and may be obtained by requesting Research Report RR: D02-1524.

selection of the sample types used in the study contributed to a difficulty in determining the precision statement. Kerosine is a sufficiently different fuel type from biodiesel to cause some slight separation of phases upon cooling when in B20 blends. Also, the particular kerosine sample used was atypical, which complicated the study further. Therefore data from the blends of kerosine in biodiesel were not used in the precision statement. In addition, the diesel fuel used in the round-robin was high cloud point material. Due to the cloud point of the base diesel material, this temperature range in the precision statement was limited.

NOTE 6—A future interlaboratory cloud study will be done including a wider range of base biodiesel fuels with various distillate blend stocks.

13.5 *Bias*—Since there is no accepted reference material suitable for determining the bias for the procedure in this test method, bias has not been determined for blends of biodiesel in diesel samples.

13.6 *Relative Bias*—The statistical analysis for the inter-laboratory test program for bias relative to Test Method D 2500/IP219 has not been determined.

14. Keywords

14.1 automatic cloud point; cloud point; D 2500 equivalent cloud point; petroleum products

ANNEX

(Mandatory Information)

A1. CLOUD POINT APPARATUS

A1.1 *Test Cell*—Borosilicate glass tube of the following dimensions: 6 ± 0.1 -mm outside diameter, 1 ± 0.05 -mm wall thickness, and 190 ± 1 -mm in length.

A1.2 *Cooling/Heating Block Assembly*(see Figs. A1.1-A1.4)—The test cell is contained within an assembly to facilitate heating and cooling of the specimen. The dimensional requirements are only such that the prescribed rate of cooling of the specimen shall be maintained. Provision shall be provided for optical detection of the end point and measure-

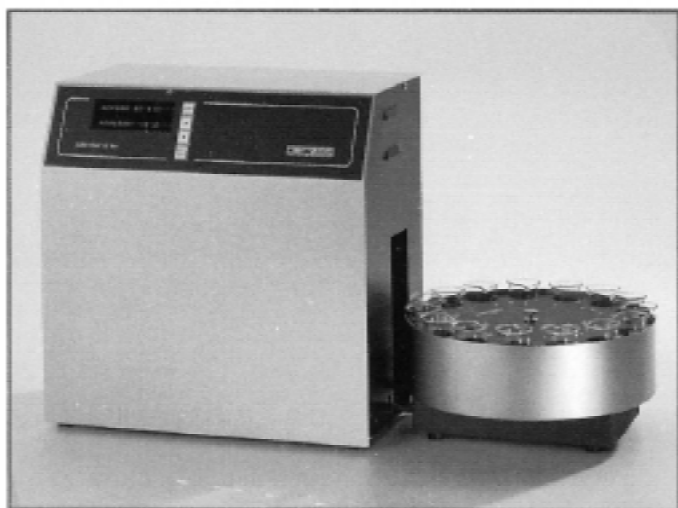

FIG. A1.1 SC 815 Automatic Cloud Point

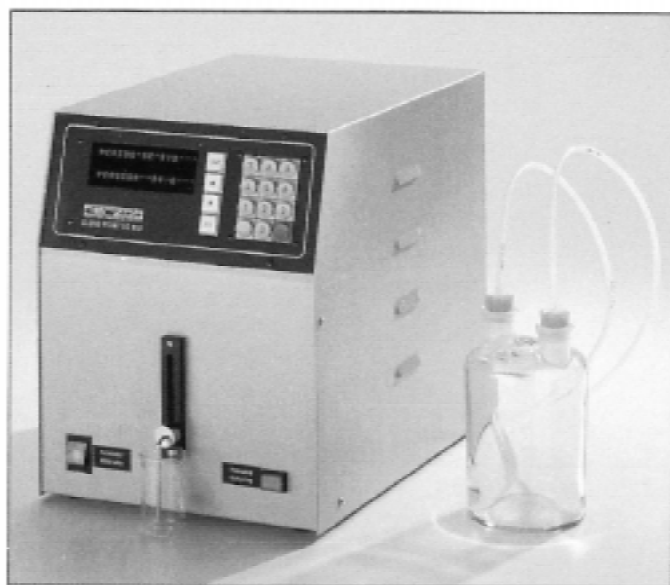

FIG. A1.2 SC 819 Automatic Cloud Point

ment of the specimen temperature.

A1.3 *Temperature Measuring Device*—The temperature measurement can be accomplished through any convenient means such as a platinum resistance device. The resolution of the temperature measurement shall be to 0.1°C and the tolerance of the device shall be less than 1 %.

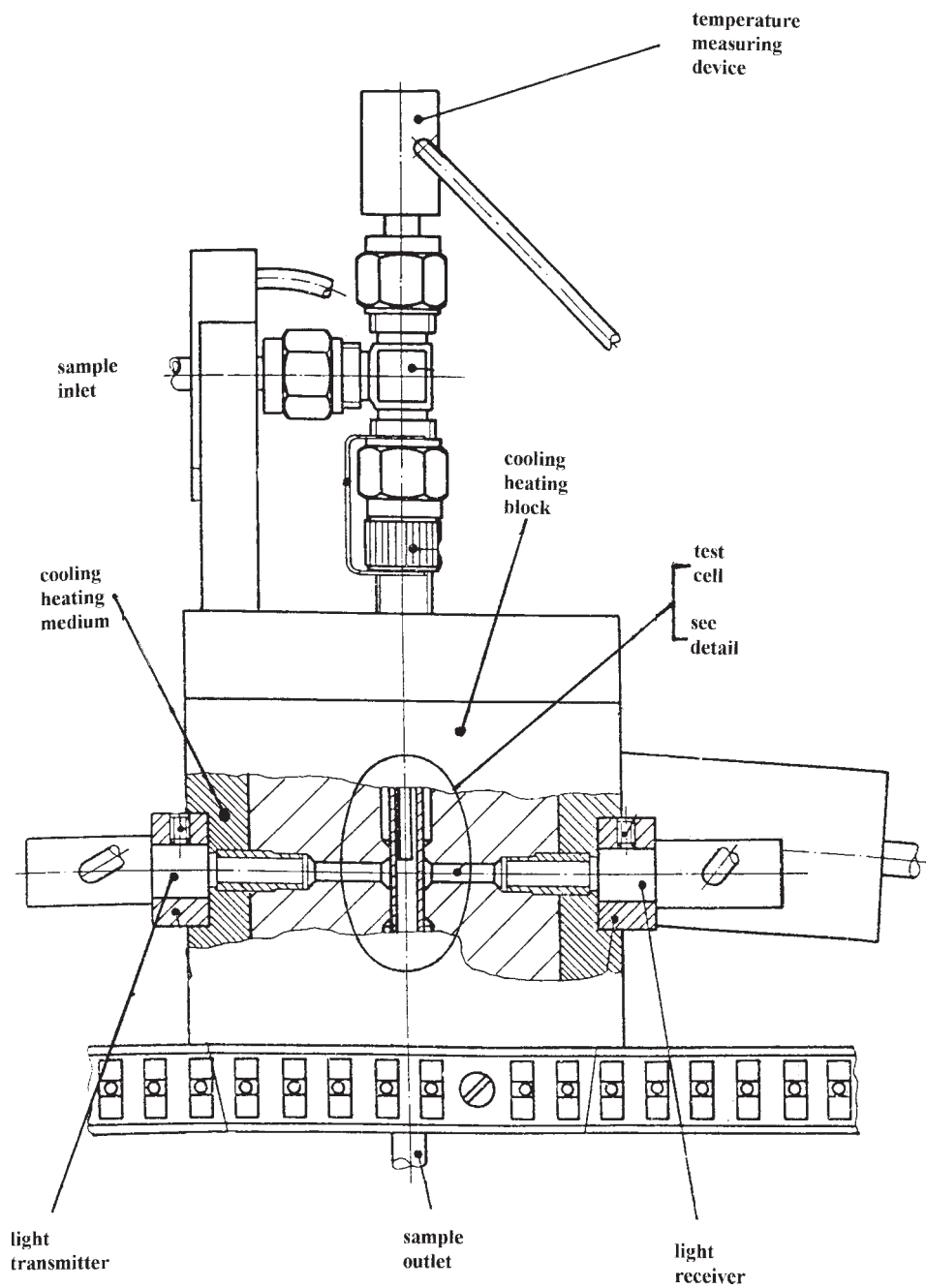
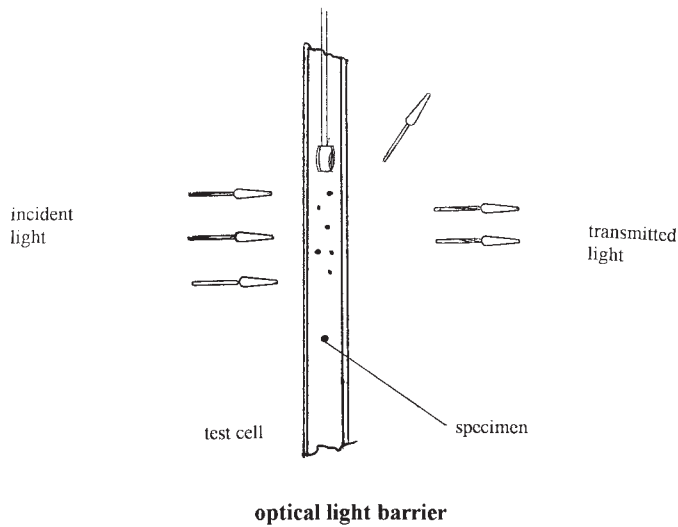

FIG. A1.3 Test Cell Assembly

temperature device



Detail

FIG. A1.4 Test Cell Assembly Detail

SUMMARY OF CHANGES

Subcommittee D02.07 has identified the location of selected changes to this standard since the last issue (D 5772-02) that may impact the use of this standard.

- (1) Revised Scope to incorporate the 1997 round robin sample temperature range.
- (2) Incorporated the 1997 round robin repeatability.
- (3) Incorporated the 1997 round robin reproducibility.
- (4) Revised 13.1.3 to reflect wording pertaining to the 1997 interlaboratory test program.
- (5) Deleted Note 6, because it was redundant with the completion of the 1997 cloud round robin.

ASTM International takes no position respecting the validity of any patent rights asserted in connection with any item mentioned in this standard. Users of this standard are expressly advised that determination of the validity of any such patent rights, and the risk of infringement of such rights, are entirely their own responsibility.

This standard is subject to revision at any time by the responsible technical committee and must be reviewed every five years and if not revised, either reapproved or withdrawn. Your comments are invited either for revision of this standard or for additional standards and should be addressed to ASTM International Headquarters. Your comments will receive careful consideration at a meeting of the responsible technical committee, which you may attend. If you feel that your comments have not received a fair hearing you should make your views known to the ASTM Committee on Standards, at the address shown below.

This standard is copyrighted by ASTM International, 100 Barr Harbor Drive, PO Box C700, West Conshohocken, PA 19428-2959, United States. Individual reprints (single or multiple copies) of this standard may be obtained by contacting ASTM at the above address or at 610-832-9585 (phone), 610-832-9555 (fax), or service@astm.org (e-mail); or through the ASTM website (www.astm.org).