



# Standard Test Method for Vapor-Phase Rust-Preventing Characteristics of Hydraulic Fluids<sup>1</sup>

This standard is issued under the fixed designation D 5534; the number immediately following the designation indicates the year of original adoption or, in the case of revision, the year of last revision. A number in parentheses indicates the year of last reapproval. A superscript epsilon ( $\epsilon$ ) indicates an editorial change since the last revision or reapproval.

## 1. Scope

1.1 This test method covers the ability of hydraulic fluids to prevent the rusting of steel in the vapor phase over the hydraulic fluid and water.

1.2 The values stated in SI units are to be regarded as the standard. The values given in parentheses are for information only.

1.3 *This standard does not purport to address all of the safety concerns, if any, associated with its use. It is the responsibility of the user of this standard to establish appropriate safety and health practices and determine the applicability of regulatory limitations prior to use.*

## 2. Referenced Documents

### 2.1 ASTM Standards:

- A 108 Specification for Steel Bars, Carbon, Cold Finished, Standard Quality<sup>2</sup>
- A 240 Specification for Heat-Resisting Chromium and Chromium-Nickel Stainless Steel Plate, Sheet, and Strip for Pressure Vessels<sup>3</sup>
- D 91 Test Method for Precipitation Number of Lubricating Oils<sup>4</sup>
- D 665 Test Method for Rust-Preventing Characteristics of Inhibited Mineral Oil in the Presence of Water<sup>4</sup>
- D 1193 Specification for Reagent Water<sup>5</sup>
- D 3603 Test Method for Rust-Preventing Characteristics of Steam Turbine Oil in the Presence of Water (Horizontal Disk Method)<sup>6</sup>
- E 1 Specification for ASTM Thermometers<sup>7</sup>

### 2.2 Other Standards:

- IP 60/80 Specification for Petroleum Spirit<sup>8</sup>

## 3. Summary of Test Method

3.1 This test method is divided into two parts:

3.1.1 Part A is used only for fluids where water is the continuous phase. Examples of such fluids include water-glycol hydraulic fluids and high-water-content hydraulic fluids. Do not use Part A to evaluate invert emulsion hydraulic fluids.

3.1.2 Part B can be used for both water-containing fluids and completely water-free fluids such as petroleum based hydraulic fluids, except phosphate esters. In Part B a small beaker of water is present to provide water vapor to cause corrosion in the absence of a vapor-phase inhibitor in the fluid. Part B is the appropriate procedure for evaluating invert emulsion hydraulic fluids.

3.2 In both Part A and Part B, a steel specimen is attached to the underside of the cover of a beaker containing the fluid under test. The apparatus and specimen are identical to those of Test Method D 3603. The fluid is brought to a test temperature of 60°C (140°F).

3.3 In Part B, the test specimen is exposed to the vapor from the fluid for 30 min prior to the introduction of water. A beaker of water is then placed in the undercarriage of the cover.

3.4 After 6 h, the apparatus is disassembled and the specimen is rated visually for the presence of rust.

3.5 Since the apparatus and test conditions are identical, Part A can be completed simultaneously with Test Method D 3603 by adding the vapor-phase specimen to that procedure.

## 4. Significance and Use

4.1 Procedures such as Test Methods D 665 and D 3603 assess the ability of new or unused hydraulic fluid to prevent rusting on wetted steel surfaces but do not address the prevention of rusting in the vapor space above the fluid. This procedure addresses the latter question under one set of test conditions and need not be applicable to some service conditions. Since used fluids have not been cooperatively tested in this procedure, its utility for in-service monitoring has not been established.

## 5. Apparatus

5.1 *Oil Bath*, a thermostatically controlled liquid bath capable of maintaining a temperature in the oil sample of 60 ±

<sup>1</sup> This test method is under the jurisdiction of ASTM Committee D-2 on Petroleum Products and Lubricants and is the direct responsibility of Subcommittee D02.N on Hydraulic Fluids.

Current edition approved Apr. 15, 1994. Published June 1994.

<sup>2</sup> *Annual Book of ASTM Standards*, Vol 01.05.

<sup>3</sup> *Annual Book of ASTM Standards*, Vol 01.03.

<sup>4</sup> *Annual Book of ASTM Standards*, Vol 05.01.

<sup>5</sup> *Annual Book of ASTM Standards*, Vol 11.01.

<sup>6</sup> *Annual Book of ASTM Standards*, Vol 05.02.

<sup>7</sup> *Annual Book of ASTM Standards*, Vol 14.03.

<sup>8</sup> Available from Applied Science Publishers, Ltd., Ripple Road, Barking, Essex, England.

1°C (140 ± 2°F). The bath shall have holes to accommodate the test beakers.

NOTE 1—The bath used for Test Method D 665 can be used with a slight modification, that is, the centers of the beaker holes are moved from 6.4 mm to 18.3 mm (1/40 23/32 in.) from the axis of the stirrers.

NOTE 2—To indicate the temperature, a thermometer conforming to the requirements of ASTM Thermometer 9C or 9F, or IP Thermometer 21C, as prescribed in Specification E 1 should be used.

5.2 *Beaker*, a 400-mL, Berzelius-type, tall-form heat resistant glass beaker,<sup>9</sup> approximately 127 mm (5 in.) in height measured from the inside bottom center and approximately 70 mm (23/4 in.) in inside diameter measured at the middle, and without pourout (see Fig. 1).

5.3 *Beaker Cover (Fig. 2) and Specimen Holder (Fig. 3)*—a flat beaker cover of 4.8 mm (3/16 in.) methyl methacrylate resin or other fluid-resistant material, kept in position by a suitable groove. Three holes, 7.9 mm (5/16 in.) in diameter, shall be provided. Two are located on any diameter of the cover, one for a stirrer 18.3 mm (23/32 in.) from the cover's center, and the other for the vapor-phase test specimen 7.9 mm (5/16 in.) from the center on the opposite side. The third hole, for a thermometer, is located 27 mm (1 1/16 in.) from the center on a diameter perpendicular to that of the other two holes. The undercarriage is a Test Method D 3603 specimen holder suitably attached to the beaker cover, used here to support the water beaker (see 5.7) used in Part B. One suitable undercarriage (the one used in the round-robin) is shown in Fig. 1. An undercarriage must be present even for Part A, to prevent vortexing. The holding rod, appropriate for this apparatus, is depicted in Fig. 4.

NOTE 3—Other holders suitable for supporting the specimen in Test

<sup>9</sup> British Standard 2, 1965 Section 5, or equivalent, may be used.

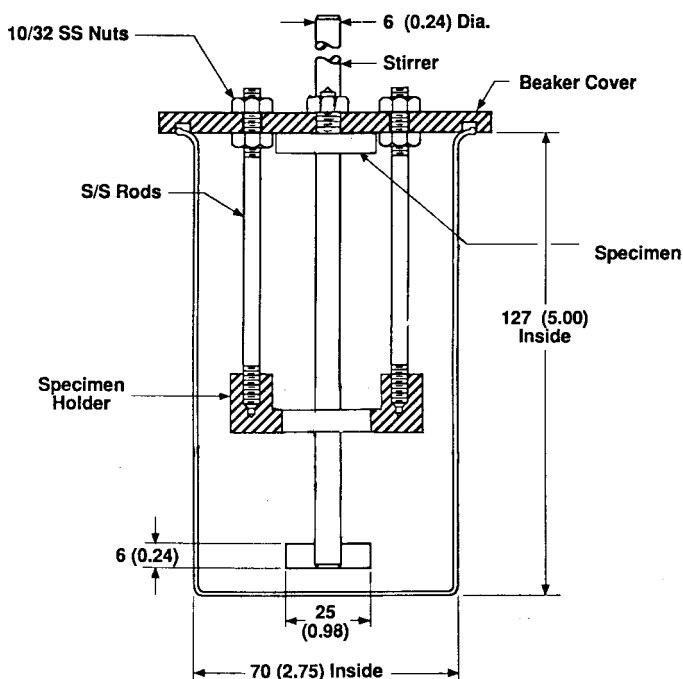

NOTE 1—All dimensions are in millimetres (inches).

FIG. 1 Rusting Test Apparatus

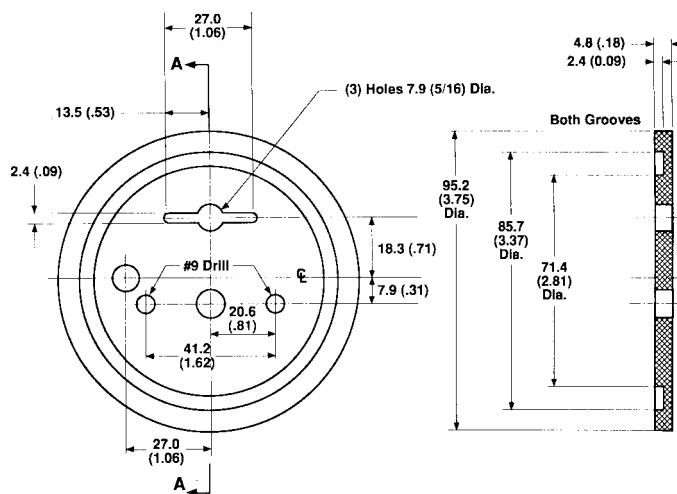

NOTE 1—All dimensions are in millimetres (inches).

FIG. 2 Beaker Cover

Method D 3603 are also suitable for supporting the water beaker in this test method. The undercarriage design is not considered to be critical.

5.4 *Stirrer*, a stirrer constructed entirely from stainless steel in the form of an inverted T (Fig. 5). A flat blade 25.4 by 6.1 by 0.6 mm (1 by 0.24 by 0.024 in.) shall be attached to a 6.1 mm (0.24 in.) rod in such a way that the blade is symmetrical with the rod and has its flat surface in the vertical pane.

NOTE 4—A suitable material is an 18 % chromium, 8 % nickel alloy steel conforming to Type 304 of Specification A 240, or SAE No. 30304, or BS 970: Part 1: 1983: 302531.

NOTE 5—If stainless steel is not available, stirrers made of heat resistant glass and having approximately the same dimensions as the stainless steel stirrers can be used.<sup>10</sup>

5.5 *Stirring Apparatus*—any convenient form of stirring apparatus capable of maintaining a speed of 1000 ± 50 rpm.

5.6 *Grinding and Polishing Equipment*—a 150- and 240-grit metalworking aluminum oxide abrasive cloth,<sup>11</sup> closed coat on a jeans backing, a suitable chuck (Fig. 6) for holding the specimen, and a means of rotating the specimen at a speed of 1700 to 1800 rpm.

5.7 *Water Beaker for Part B*—a flat-bottomed beaker made from 30 mm (1.2 in.) outside diameter standard wall glass tubing, 50 mm (2.0 in.) high. It should fit snugly in the undercarriage of the specimen holder.

## 6. Reagents and Materials

6.1 *Cleaning Agents*—One of the following shall be used.

6.1.1 *ASTM Precipitation Naphtha*, conforming to Test Method D 91.

NOTE 6—**Warning:** Precipitation naphtha is flammable and a health hazard.

6.1.2 *Isooctane*, conforming to Annex A2. on Reference Materials and Blending Accessories.<sup>11</sup> Previously used, un-rusted specimens shall be stored in this reagent.

<sup>10</sup> Borosilicate glass is satisfactory for this purpose.

<sup>11</sup> *Annual Book of ASTM Standards*, Vol 05.04 (gray pages).

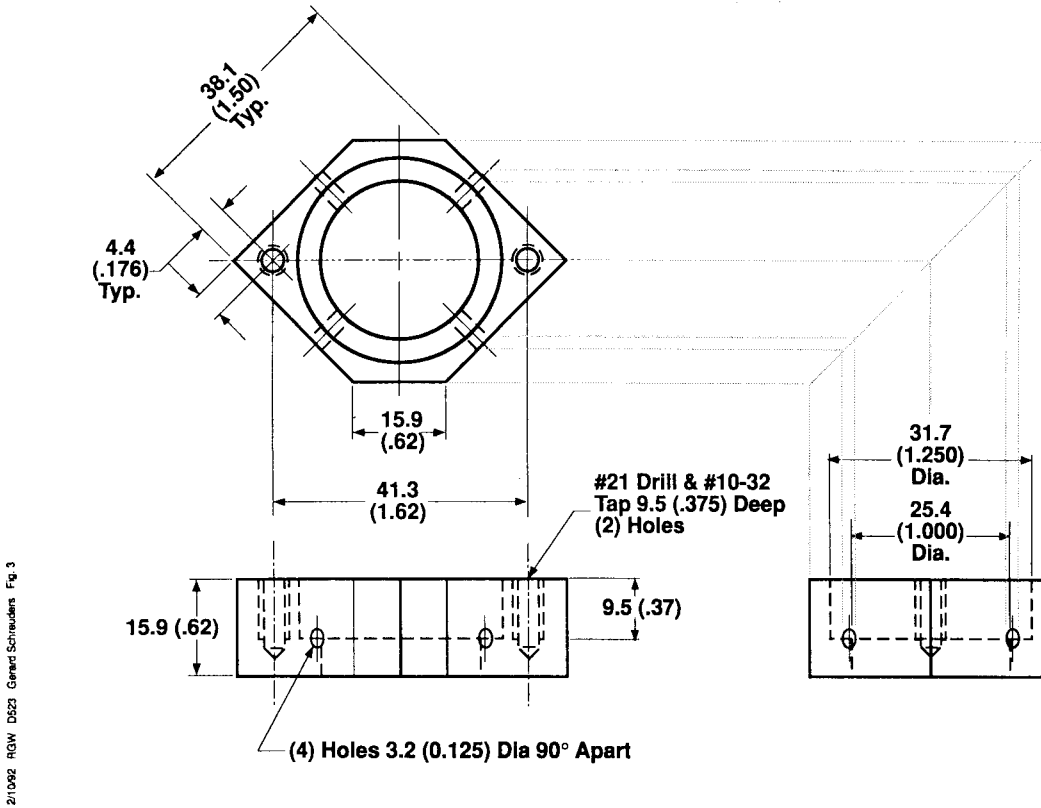

NOTE 1—All dimensions are in millimetres (inches).

FIG. 3 Specimen Holder

NOTE 7—**Warning:** Isooctane is flammable and a health hazard.

6.1.3 *IP Petroleum Spirit*, conforming to IP Specification 60/80.

NOTE 8—**Warning:** IP petroleum spirit is flammable and a health hazard.

### 7. Test Specimens and Their Preparation

7.1 The steel coupon, when new, shall be 30.2 mm ( $1\frac{3}{16}$  in.) in diameter and 4.8 mm ( $\frac{3}{16}$  in.) thick, with a 6.4 mm ( $\frac{1}{4}$  in.) central threaded shaft 9.5 mm ( $\frac{3}{8}$  in.) long (Fig. 7). Specimens should be discarded when they reach a thickness of 1.6 mm ( $\frac{1}{16}$  in.) after repeated use.

7.2 Coupons shall be made of steel conforming to Grade 1018 of Specification A 108, or to BS 970: 1955-EN3B.

NOTE 9—When making a check test, the steel coupon that showed rust should not be reused. Steel coupons that repeatedly show rust in tests of various oils might be imperfect. Such coupons should be used with oils known to pass the test. If rusting results, the coupons should be discarded.

7.3 Steel coupons, either new or from a previous test (previously used coupons shall be stored in isooctane) shall be

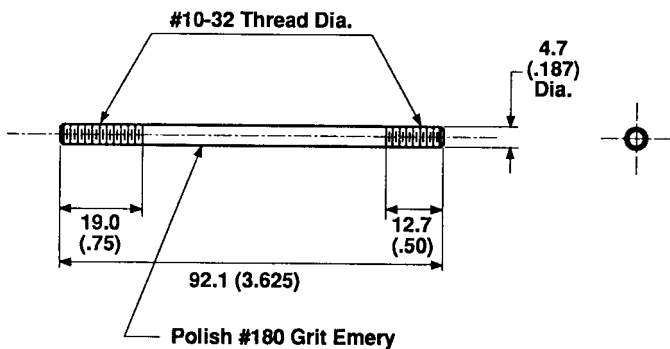

NOTE 1—All dimensions are in millimetres (inches).

FIG. 4 Holding Rod

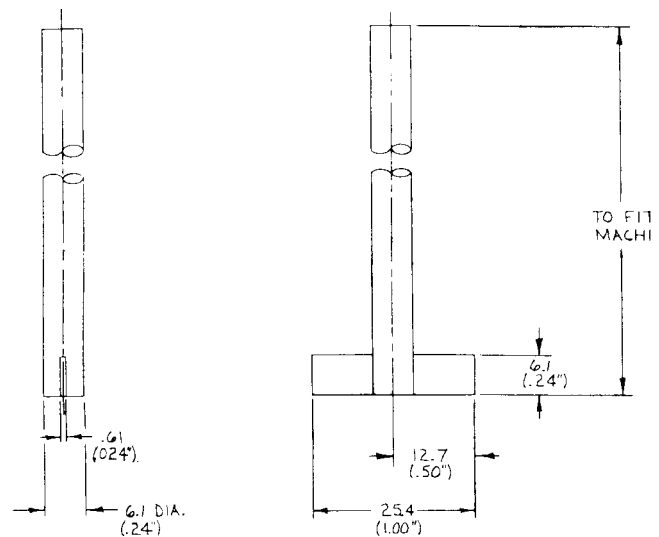

NOTE 1—All dimensions are in millimetres (inches).

NOTE 2—<sup>125</sup> all over.

NOTE 3—All dimensions  $\pm 0.5$  mm (0.02 in.).

NOTE 4—Break all sharp corners.

FIG. 5 Stirrer

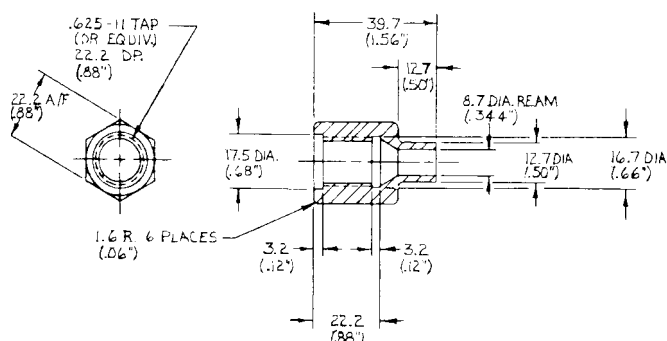

NOTE 1—Tap dimensions are in inches. All others are in millimetres (inches).

NOTE 2—<sup>125</sup> all over.

NOTE 3—All dimensions  $\pm 0.5$  mm (0.02 in.).

NOTE 4—Break all sharp corners.

FIG. 6 Chuck for Polishing Test Specimens

prepared as described in 7.4 and 7.5.

7.4 *Preliminary Grinding*—If the coupons have been used previously and are free from rust or other irregularities the preliminary grinding may be omitted, and they may be subjected to only final polishing as prescribed in 7.5. If the specimens are new or if any part of their surfaces show rust or other irregularities, clean them with ASTM precipitation naphtha or isooctane or IP 60/80 petroleum spirit and grind them with medium 150-grit aluminum oxide cloth to remove all irregularities, pits and scratches, as determined by visual inspection.

7.4.1 Do not touch the specimen with the hands at any stage after cleaning with naphtha or isooctane or the petroleum spirit (which precedes either preliminary grinding or final polishing) until the test is completed. Forceps or a clean lintless cloth may be used.

7.5 *Final Polishing*—Just before the test is to be made, polish the specimens with a 240-grit aluminum oxide cloth. If the preliminary grinding has just been completed, stop the motor which rotates the specimen. Otherwise, remove the specimen from the isooctane (previously used unruined specimens shall be stored in this reagent), dry with a clean cloth, and place in a chuck.

7.5.1 *Steel Coupon*—When polishing a steel coupon, rub a new piece of 240-grit aluminum oxide cloth across the flat test surface until the entire surface shows visible straight scratches.

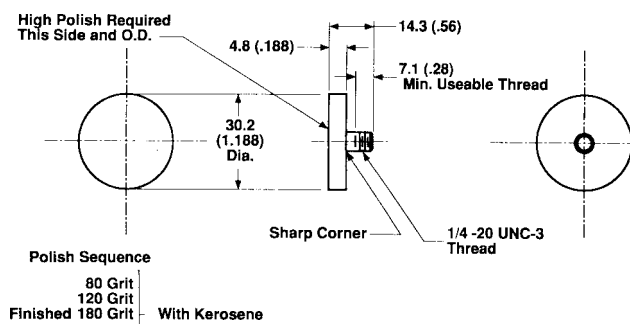

NOTE 1—All dimensions are in millimetres (inches).

FIG. 7 Steel Coupon

Rotate the coupon at a speed of 1700 to 1800 rpm and polish with a strip of 240-grit aluminum oxide cloth by pressing firmly against the cloth with the flat of the thumb and slowly moving it back and forth across the flat surface to produce a uniform finely scratched surface free from straight scratches. Carry out the final stages of the polishing with new cloth. Use only the flat surface in evaluating the test. However, the edge and surface adjacent to the shaft should be rust free, not necessarily polished, at the start of the test.

## 8. Procedure

8.1 Clean the beaker in accordance with good laboratory procedure, rinse it with distilled water (see Specification D 1193) and dry it in an oven. Clean the stainless steel stirrer and plastic beaker cover and specimen holder assembly with ASTM precipitation naphtha, isooctane, or 60/80 petroleum spirit, and dry thoroughly at room temperature.

NOTE 10—In cases of dispute the parties are to agree on a glassware cleaning procedure. However, the roundrobin was conducted with glassware cleaned with chromic acid.

8.2 Being careful to avoid fingerprints, attach the steel coupon by its threaded portion to the underside of the beaker cover. The coupon can be threaded into a Test Method D 3603 vertical specimen or plastic cap, a 1/4 in.—20 UNC nut, a thin piece of plastic with a 5-mm (3/16-in.) hole, or any other convenient support.

8.3 Pour 275 mL of the fluid to be tested into the beaker and place the beaker in the oil bath held at a temperature that will maintain  $60 \pm 1^\circ\text{C}$  ( $140 \pm 2^\circ\text{F}$ ) in the oil sample. Insert the beaker into a hole in the bath cover so that the beaker is suspended with the rim resting on the bath cover. The oil level in the bath shall not be below the oil level in the test beaker. Lower the assembly into the oil sample until the cover rests on the beaker rim. Insert the thermometer in the beaker so that the bulb is positioned approximately 20 mm (3/4 in.) from the bottom of the beaker. Place the stirrer in position so that it does not touch the coupons when turning and is within 2.0 mm (0.08 in.) of the bottom of the beaker. Start the stirrer and stir while the temperature of the sample reaches  $60 \pm 1^\circ\text{C}$  ( $140 \pm 2^\circ\text{F}$ ).

8.4 For Part A, time 6 h from the time the temperature reaches  $60 \pm 1^\circ\text{C}$  ( $140 \pm 2^\circ\text{F}$ ).

8.5 For Part B, allow the sample to stir for 30 min after its temperature reaches  $60 \pm 1^\circ\text{C}$  ( $140 \pm 2^\circ\text{F}$ ). Then stop the stirrer, remove the thermometer and raise the beaker cover. Place the water beaker containing 25 mL of deionized water in the undercarriage, replace the cover assembly, replace the thermometer, start the stirrer and time 6 h from that time.

8.6 After the 6 h has elapsed, stop the stirrer, disassemble the apparatus, and remove the test coupon. Wash with ASTM precipitation naphtha or isooctane or 60/80 petroleum spirit. After the steel coupon is rated, it can be preserved for reference by lacquering. If repeated polishing has not rendered the coupon excessively convex, the degree of rusting may also be archived by photocopying the coupon.

8.7 All inspections at the end of the test to determine the condition of coupons shall be performed without magnification under normal light. For the purpose of this test normal light is considered to be illumination of about 646 lx (60 fc).

8.8 In order to report an oil as passing or failing, the test must be conducted in duplicate. An oil shall be reported as passing the test if both coupons meet the passing criterion in 8.9. An oil shall be reported as failing the test if duplicate coupons fail according to 8.10. If one coupon fails while the other passes, tests on two additional coupons shall be completed. If either of these latter coupons fails, the oil shall be reported as failing the test. If neither of these latter coupons shows rusting, the oil shall be reported as passing the test.

8.9 If a coupon shows any rust spot or rust streak visible on the horizontal test surface (the surface facing the liquid) it should be reported as failing. Rust on other surfaces of the coupon should be disregarded.

## 9. Report

9.1 Report results as pass or fail. For water-continuous fluids, the report should indicate whether the procedure of Part A or Part B was used. The procedure of Part B is understood for non-water-containing fluids.

*The American Society for Testing and Materials takes no position respecting the validity of any patent rights asserted in connection with any item mentioned in this standard. Users of this standard are expressly advised that determination of the validity of any such patent rights, and the risk of infringement of such rights, are entirely their own responsibility.*

*This standard is subject to revision at any time by the responsible technical committee and must be reviewed every five years and if not revised, either reapproved or withdrawn. Your comments are invited either for revision of this standard or for additional standards and should be addressed to ASTM Headquarters. Your comments will receive careful consideration at a meeting of the responsible technical committee, which you may attend. If you feel that your comments have not received a fair hearing you should make your views known to the ASTM Committee on Standards, 100 Barr Harbor Drive, West Conshohocken, PA 19428.*

## 10. Precision and Bias

10.1 Using the procedure of Part A, all nine cooperators successfully differentiated an inhibited from a noninhibited water-glycol hydraulic fluid and high-water-content hydraulic fluid.

10.2 Using the procedure of Part B, seven of eight cooperators successfully differentiated inhibited from noninhibited petroleum-based and water-glycol hydraulic fluids.

10.3 Since there is no other standard for judging the properties measured by this test procedure, the results are not relatable to known levels of vapor-phase corrosion protection and the bias of this test method is, therefore, not definable.

## 11. Keywords

11.1 hydraulic oil; invert emulsion; rust-preventing characteristics; vapor-phase rust; water-glycol hydraulic fluid