



Standard Test Method for Apparent Density by Physical Measurements of Manufactured Anode and Cathode Carbon Used by the Aluminum Industry¹

This standard is issued under the fixed designation D 5502; the number immediately following the designation indicates the year of original adoption or, in the case of revision, the year of last revision. A number in parentheses indicates the year of last approval. A superscript epsilon (ϵ) indicates an editorial change since the last revision or reapproval.

1. Scope

1.1 This test method covers the determination of the apparent density of core samples from manufactured articles of anode and cathode carbon used by the aluminum industry in the production of aluminum.

1.2 The values stated in SI units are to be regarded as the standard. The values given in parentheses are for information only.

1.3 *This standard does not purport to address all of the safety concerns, if any, associated with its use. It is the responsibility of the user of this standard to establish appropriate safety and health practices and determine the applicability of regulatory limitations prior to use.*

2. Referenced Documents

2.1 ASTM Standards:

C 559 Test Method for Bulk Density by Physical Measurements of Manufactured Carbon and Graphite Articles²

IEEE/ASTM SI 10 Standard for Use of the International System of Units (SI): (The Modern Metric System)³

3. Terminology

3.1 Definitions:

3.1.1 *apparent density*—the weight per unit volume of a substance, including voids inherent in the material tested.

4. Significance and Use

4.1 Apparent density as determined by this test method is a basic material property of importance in manufacturing and application of anode and cathode carbon.

4.2 This test method can be used for quality and process control, material characterization and description, and other purposes.

5. Apparatus

5.1 *Drying Oven*, capable of being controlled to $110 \pm 5^\circ\text{C}$ ($230 \pm 9^\circ\text{F}$).

5.2 *Desiccator*, charged with indicating desiccant.

5.3 *Balance*, capable of weighing to ± 0.01 g.

5.4 *Core Drill*, drill equipped with a diamond core bit capable of producing a core with a minimum diameter of 50 mm with true surface qualities.

5.5 *Cut-Off Saw*, a saw capable of cutting the cored sample resulting in a surface free of chips or gouges.

5.6 *Micrometer*, a micrometer or other measuring device capable of measuring the diameter and length of the prepared sample to an accuracy of 0.001 cm.

6. Preparation of Test Specimens

6.1 Core drill samples with a minimum diameter of 50 mm from the manufactured article in the form of a right circular cylinder.

6.2 Cut samples from the core to a minimum length of 50 mm. It is recommended that triplicate samples from the core be prepared, analyzed, and averaged to attain a result representative of the core apparent density.

6.3 It is the responsibility of the user of this standard to establish the quantity and location of core samples from the manufactured article for testing.

6.4 No particle contained within the sample can be larger than 19 mm. If particles are larger the sample size, quantity, or both, must be increased accordingly to give comparable accuracy in the results.

6.5 During the coring operation, use no lubricant having a boiling point above 100°C . All edges and faces of the specimen should be free of chips or gouges. Ensure that the specimen is free of any residue from the coring operation. Dry the specimen for a minimum of 2 h at 110°C , and then allow it to cool to $25 \pm 5^\circ\text{C}$ in a desiccator. The specimen shall not be removed from the desiccator until immediately prior to weighing.

7. Procedure

7.1 Weigh the prepared specimen to an accuracy of 0.01 g using a balance or scale.

¹ This test method is under the jurisdiction of ASTM Committee D02 on Petroleum Products and Lubricants and is the direct responsibility of Subcommittee D02.05.01 on Petroleum Coke Sampling and Procedures.

Current edition approved June 10, 2000. Published July 2000. Originally published as D 5502 - 94. Last Previous edition D 5502 - 99.

² *Annual Book of ASTM Standards*, Vol 05.05.

³ *Annual Book of ASTM Standards*, Vol 14.02.

7.2 Measure each dimension of the test specimen to an accuracy of 0.001 cm.

7.2.1 Measure the length at four points, 90° apart on the periphery of the circular end faces. Make two sets of diameter measurements. Each set shall consist of four measurements, one at each end and two at intermediate points along an axial line. These sets shall lie at 90° to each other. Determine the mean of the four length measurements (*l*) (see Fig. 1) and the mean of the eight diameter measurements (*d*) (see Fig. 2).

8. Calculation

8.1 Record the mass to the nearest .01 g and the dimensions to the nearest .001 cm. Conversion factors are available in IEEE/ASTM SI 10.

8.2 The volume of the right circular cylinder specimen can be calculated as follows:

$$V = \pi(d^2/4)l \tag{1}$$

where:

- V* = volume, cm³,
- l* = mean length, cm, and
- d* = mean diameter, cm.

8.3 The apparent density of the specimen can be calculated as follows:

$$D = M/V \tag{2}$$

where:

- D* = apparent density, g/cm³,
- M* = mass, g, and
- V* = volume, cm³.

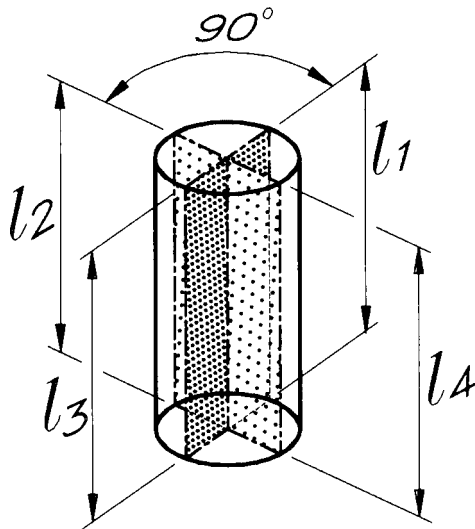

FIG. 1 Determining the Mean of the Four Length Measurements

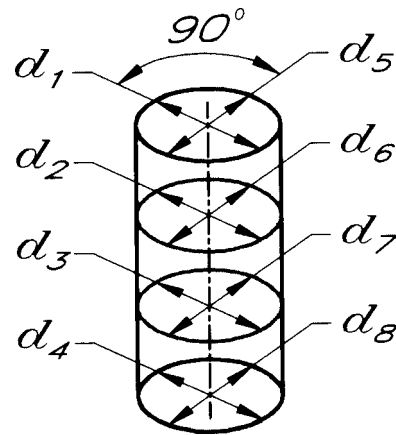

FIG. 2 Determining the Mean of the Eight Diameter Measurements

9. Report

9.1 Report the following information:

- 9.1.1 Type, source, and form of the original article.
- 9.1.2 Apparent densities of the individual specimens and the mean reported to the third decimal point (.001 g/cc).

10. Precision and Bias ⁴

10.1 *Precision*—The precision of this test method as determined by the statistical examination of the inter-laboratory test results is as follows:

10.1.1 *Repeatability*—The difference between successive results obtained by the same operator with the same apparatus under constant operating conditions on identical test materials would, in the long run, in the normal and correct operation of the test method exceed the following values only in one case in twenty.

$$\text{Repeatability} = 0.005 \tag{3}$$

10.1.2 *Reproducibility*—The difference between two single and independent results obtained by different operators working in different laboratories on identical material would in the long run, exceed the following values only in one case in twenty.

$$\text{Reproducibility} = 0.015 \tag{4}$$

NOTE 1—The values in the statements were determined in a cooperative program following RR:D02-1007.⁵

11. Keywords

11.1 aluminum industry; anode; anode carbon; apparent density; bulk density; cathode; cathode carbon; core; density

⁴ Round-robin data is available from ASTM Headquarters. Request RR:D02-1318.

⁵ This research report is available from ASTM Headquarters. Request RR:D02-1007.

The American Society for Testing and Materials takes no position respecting the validity of any patent rights asserted in connection with any item mentioned in this standard. Users of this standard are expressly advised that determination of the validity of any such patent rights, and the risk of infringement of such rights, are entirely their own responsibility.

This standard is subject to revision at any time by the responsible technical committee and must be reviewed every five years and if not revised, either reapproved or withdrawn. Your comments are invited either for revision of this standard or for additional standards and should be addressed to ASTM Headquarters. Your comments will receive careful consideration at a meeting of the responsible technical committee, which you may attend. If you feel that your comments have not received a fair hearing you should make your views known to the ASTM Committee on Standards, at the address shown below.

 **D 5502**

This standard is copyrighted by ASTM, 100 Barr Harbor Drive, PO Box C700, West Conshohocken, PA 19428-2959, United States. Individual reprints (single or multiple copies) of this standard may be obtained by contacting ASTM at the above address or at 610-832-9585 (phone), 610-832-9555 (fax), or service@astm.org (e-mail); or through the ASTM website (www.astm.org).