



Standard Test Methods for Hydroxypropylcellulose¹

This standard is issued under the fixed designation D 5400; the number immediately following the designation indicates the year of original adoption or, in the case of revision, the year of last revision. A number in parentheses indicates the year of last reapproval. A superscript epsilon (ϵ) indicates an editorial change since the last revision or reapproval.

1. Scope

1.1 These test methods cover the testing of hydroxypropylcellulose.

1.2 The test procedures appear in the following order:

	Sections
Moisture	4 to 9
Viscosity	10 to 16
pH	17 to 21
Residue on Ignition	22 to 28
Hydroxypropoxy Content	29 to 36

1.3 *This standard does not purport to address all of the safety concerns, if any, associated with its use. It is the responsibility of the user of this standard to establish appropriate safety and health practices and determine the applicability of regulatory limitations prior to use.* For specific hazard statements, see Note 2.

2. Referenced Documents

2.1 ASTM Standards:

D 3876 Test Method for Methoxyl and Hydroxypropyl Substitution in Cellulose Ether Products by Gas Chromatography²

E 70 Test Method for pH of Aqueous Solutions With the Glass Electrode³

3. Reagents

3.1 *Purity of Reagents*—Reagent grade chemicals shall be used in all tests. Unless otherwise indicated, it is intended that all reagents shall conform to the specifications of the Committee on Analytical Reagents of the American Chemical Society, where such specifications are available.⁴ Other grades may be

used, provided it is first ascertained that the reagent is of sufficiently high purity to permit its use without lessening the accuracy of the determination.

3.2 *Purity of Water*—Unless otherwise indicated, references to water shall be understood to mean distilled water.

MOISTURE

4. Scope

4.1 This test method covers the determination of the volatile content of hydroxypropylcellulose.

5. Significance and Use

5.1 The results of this test are used for calculating the total solids in the sample; and, by common usage, all materials volatile at this test temperature are designated as moisture.

5.2 Moisture analysis (along with residue on ignition) is a measure of the amount of active polymer in the material and must be considered when determining the amount of hydroxypropylcellulose to use in various formulations.

6. Apparatus

6.1 *Oven*, gravity convection, capable of maintaining a temperature of $105 \pm 3^\circ\text{C}$.

6.2 *Weighing Dish*, glass or aluminum, with cover, 50 mm in diameter, 25 mm in height, or equivalent.

6.3 *Analytical Balance*.

7. Procedure

7.1 Weigh about 5 g of sample to the nearest 0.001 g in a tared and covered weighing dish.

7.2 Place it in an oven at $105 \pm 1^\circ\text{C}$ for 3 h with the cover removed.

7.3 Remove the dish from the oven, immediately replace the cover, cool in a desiccator, and weigh.

8. Calculation

8.1 Calculate the percent moisture, M , as follows:

$$M = (A/B) \times 100 \quad (1)$$

where:

A = mass loss on heating, g, and

¹ These test methods are under the jurisdiction of ASTM Committee D-1 on Paint and Related Coatings, Materials, and Applications and is the direct responsibility of Subcommittee D01.36 on Cellulose and Cellulose Derivatives.

Current edition approved May 15, 1993. Published July 1993.

² *Annual Book of ASTM Standards*, Vol 06.03.

³ *Annual Book of ASTM Standards*, Vol 15.05.

⁴ *Reagent Chemicals, American Chemical Society Specifications*, American Chemical Society, Washington, DC. For suggestions on the testing of reagents not listed by the American Chemical Society, see *Analar Standards for Laboratory Chemicals*, BDH Ltd., Poole, Dorset, U.K., and the *United States Pharmacopeia and National Formulary*, U.S. Pharmacopeial Convention, Inc. (USPC), Rockville, MD.

B = sample used, g.

8.2 Report the moisture content to the nearest 0.1 %.

9. Precision and Bias

9.1 *Precision*—Statistical analysis of intralaboratory test results on samples containing from 1 to 6 % moisture indicates a precision of ±0.2 % absolute at the 95 % confidence level.

9.2 *Bias*—No justifiable statement on bias can be made as no suitable reference material is available as a standard.

VISCOSITY

10. Scope

10.1 This test method is an arbitrary method of determining the viscosity of aqueous solutions of hydroxypropylcellulose in the viscosity range of 10 to 16 000 cP/s at 25°C.

10.2 The concentration to be used for the test shall be agreed upon between the purchaser and the seller. It shall be such that the viscosity of the solution will fall within the range of this test.

10.3 The results for the viscosity of hydroxypropylcellulose by this test method will not necessarily check with results from other types of instruments used for viscosity measurement.

10.4 The determinations are run on a calculated dry basis; that is, the amount of hydroxypropylcellulose required for the desired concentration on a dry basis is calculated from the known moisture content.

11. Significance and Use

11.1 This test method is intended for referee purposes. The Brookfield⁵ spindles and speeds given in Table 1 are recommended for this purpose, but slight deviations from Table 1 may occasionally be found convenient for individual application.

TABLE 1 Brookfield^A Viscometer Spindle and Speed Combinations

Viscosity Range, cP	Spindle Number	Speed, r/min	Scale	Factor
10–80	1	60	100	1
20–160	1	30	100	2
50–400	2	60	100	5
100–800	2	30	100	10
400–1600	3	60	100	20
800–3200	3	30	100	40
2000–8000	4	60	100	100
4000–16 000	4	30	100	200

^ABrookfield Viscometer, Model LVF⁵.

11.2 This test method determines the relative ability of the polymer to thicken aqueous solutions and is therefore related to the concentration required in various formulations to achieve the desired finished product viscosity.

12. Apparatus

12.1 *Viscometer*, Brookfield Type.⁵

⁵ Model LVF, available from Brookfield Engineering Laboratories, Inc., Stoughton, MA has been found satisfactory for this purpose.

12.2 *Container*, glass bottle, 12-oz (350-cm³) approximately 2½ in. (64 mm) in outside diameter and 6 in. (152 mm) high.

12.3 *Mechanical Stirrer*, agitator as shown in Fig. 1, attached to a variable-speed motor capable of 1500 r/min.

12.4 *Water Bath*, constant-temperature, set at 25°C and capable of maintaining that temperature to within ± 0.5°C.

13. Procedure

13.1 Determine the moisture in accordance with Sections 4-9.

13.2 Calculate the sample mass, S , in grams necessary to make 250 g of test solution as follows:

$$S = \frac{A \times 100}{100 - B} \tag{2}$$

where:

A = desired dry mass of sample, g, and

B = percent moisture in the weighed sample.

13.3 Calculate the mass of water required, W , in grams as follows:

$$W = 250 - S \tag{3}$$

where:

S = sample mass, g.

13.4 Weigh the water into the glass bottle and place it on the stirrer, mixing at a speed sufficient to cause a vortex but not fast enough to splash.

13.5 Sprinkle the hydroxypropylcellulose sample into the water slowly, to prevent lumping. Increase stirring speed to

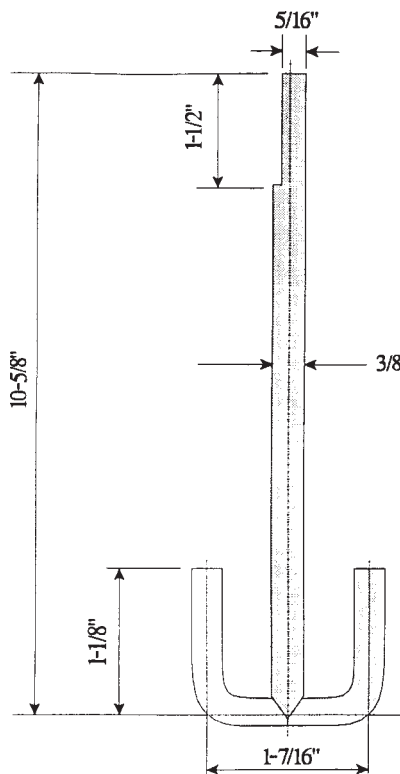

FIG. 1 Stainless Steel Agitator

approximately 900 ± 100 r/min and stir until the sample is completely dissolved (1 to 2 h).

13.6 Remove the glass bottle from the stirrer, cap the bottle, and place it in the constant temperature bath for 30 min or as long as necessary to bring the solution to $25 \pm 0.5^\circ\text{C}$.

13.7 Remove the glass bottle from the water bath and invert it slowly 4 to 5 times, taking care to minimize the introduction of air bubbles.

13.8 Measure the viscosity with the Brookfield viscometer, following the manufacturer's operating instructions. Select the proper spindle and speed from Table 1. Allow the spindle to rotate for 3 min before taking the reading. Use the spindle guard.

NOTE 1—If the room temperature is considerably greater or less than 25°C ; the entire operation of stirring, standing, and measurement should be conducted with the glass bottle suspended in the constant temperature bath.

14. Calculation

14.1 Calculate the viscosity, V , in centipoises as follows:

$$V = r \times f \quad (4)$$

where:

r = scale reading and

f = factor from Table 1.

15. Report

15.1 Report the following information:

15.1.1 Results, as Brookfield viscosity at 25°C ,

15.1.2 Solution concentration,

15.1.3 Spindle used, and

15.1.4 Speed used.

16. Precision and Bias

16.1 *Precision*—Statistical analysis of interlaboratory test results indicates a precision of $\pm 10\%$ at the 95 % confidence level.

16.2 *Bias*—No justifiable statement on bias can be made as no suitable reference material is available as a standard.

pH

17. Scope

17.1 This test method covers the determination of the pH of aqueous solutions of hydroxypropylcellulose.

18. Significance and Use

18.1 This test method determines the relative acidity or alkalinity of aqueous solutions of hydroxypropylcellulose. This must be taken into consideration when determining materials of construction for equipment and packaging for handling and storing these solutions. Also, pH may affect suitability for certain end-use applications.

19. Apparatus

19.1 *pH Meter*, with glass electrodes.

20. Procedure

20.1 Determine the pH of the viscosity solution from 13.5, using a suitable pH meter that has been standardized according to Test Method E 70.

21. Precision and Bias

21.1 *Precision*—Statistical analysis of intralaboratory test results on samples with pH values of 4.5 to 8.5 indicates a precision of $\pm 5\%$ at the 95 % confidence level.

21.2 *Bias*—No justifiable statement on bias can be made as no suitable reference material is available as a standard.

RESIDUE ON IGNITION

22. Scope

22.1 This test method covers the determination of the amount of residue left from igniting a sample of hydroxypropylcellulose after being moistened first with sulfuric acid and then with hydrofluoric acid.

23. Significance and Use

23.1 Excessive residue on ignition can affect solution clarity and film properties. The residue on ignition (along with moisture) is a measure of the amount of active polymer in the material and must be considered when determining the amount of hydroxypropylcellulose to use in various formulations.

23.2 Commercially available hydroxypropylcellulose most often has up to 0.60 % silica added as an anti-caking agent. Therefore, a hydrofluoric acid ashing step is required to remove the silica.

24. Apparatus

24.1 *Dishes*, platinum, 75-mL capacity.

24.2 *Hot Plate*.

24.3 *Muffle Furnace*, capable of reaching $1000 \pm 25^\circ\text{C}$.

25. Reagents

25.1 *Sulfuric Acid*, (sp gr 1.84)—concentrated sulfuric acid (H_2SO_4).

25.2 *Hydrofluoric Acid* (48 %).

26. Procedure

26.1 Weigh, to the nearest 0.0001 g, about 1 g of hydroxypropylcellulose into a tared platinum dish. Using a hot plate, heat the dish containing the sample (gently at first) until the sample is thoroughly charred. Cool the dish for several minutes.

26.2 Moisten the residue with about 1 mL of sulfuric acid and heat gently on the hot plate until white fumes are no longer evolved.

26.3 Place the dish in a muffle furnace at $800 \pm 25^\circ\text{C}$ for 30 min. Allow the dish to cool.

26.4 Repeat 26.2 and 26.3. Cool in a desiccator. Weigh the residue (R_1).

26.5 Moisten the residue with up to 1 mL of water and carefully add about 5 mL of hydrofluoric acid, in small portions. Evaporate to dryness on a hot plate in a fume hood. Allow the dish to cool.

26.6 Carefully add about 5 mL of hydrofluoric acid and 0.5 mL of sulfuric acid and evaporate to dryness on a hot plate in a fume hood.

NOTE 2—**Precaution:** Hydrofluoric acid is a poisonous and extremely hazardous acid because of its ability to cause severe burns that are not

immediately painful or visible. Use extreme care in handling.

26.7 Place the dish in a muffle furnace at $1000 \pm 25^\circ\text{C}$ for 20 min. Allow the dish to cool in a desiccator. Weigh the residue (R_2).

27. Calculations

27.1 Calculate the percent residue on ignition, RI , as follows:

$$RI = (R_2/S) \times 100 \quad (5)$$

where:

R_2 = ash after ignition with hydrofluoric acid, g, and
 S = sample used, g.

27.2 The percent silica content, Si , may be calculated as follows:

$$Si = [R_1 - R_2]/S \times 100 \quad (6)$$

where:

R_1 = ash after ignition with sulfuric acid, g,
 R_2 = ash after ignition with hydrofluoric acid, g, and
 S = sample used, g.

28. Precision and Bias

28.1 *Precision*—Statistical analysis of intralaboratory test results on samples containing 0.00 to 0.30 % residue on ignition indicates a precision of ± 10 % at the 95 % confidence level.

28.2 *Bias*—No justifiable statement on bias can be made as no suitable reference material is available as a standard.

HYDROXYPROPOXY CONTENT^{6,7}

29. Scope

29.1 This test method covers the determination of the hydroxypropoxy content of hydroxypropylcellulose.

30. Summary of Test Method

30.1 A sample of hydroxypropylcellulose is refluxed with aqueous chromic acid solution. The resulting acetic acid is distilled and titrated with standard sodium hydroxide solution.

31. Significance and Use

31.1 This test method determines the amount of substituent groups added to the cellulose backbone. The level can affect solution properties, rheology, solubility parameters, and film properties.

31.2 Gas chromatographic procedures involving cleavage of side groups with hydriodic acid (see Test Method D 3876) are not applicable for highly substituted hydroxypropylcellulose because the amount of hydriodic acid and the temperature

required to achieve complete reaction lead to side reactions that render the method non-quantitative.

32. Apparatus

32.1 *Chromic Acid Oxidation Apparatus*, as illustrated in Fig. 2. The inlet for nitrogen and water in the reaction flask is a 1-mm capillary tip.

32.2 *Oil Bath*, equipped with an electrical heating device so the bath can be maintained at 155°C .

32.3 *Analytical Balance*, capable of weighing to 0.0001 g.

33. Reagents

33.1 *Chromium Trioxide Solution (30 %)*—Dissolve 30 g of chromium trioxide (CrO_3) in 70 ml of water.

33.2 *Nitrogen*—Use a nitrogen cylinder with suitable reducing valve.

33.3 *Potassium Iodide (KI)*.

33.4 *Sodium Bicarbonate (NaHCO_3)*—powder.

33.5 *Sodium Hydroxide Standard Solution (0.02 N)*, carbon dioxide free.

33.6 *Sodium Thiosulfate Standard Solution (0.02 N)*.

33.7 *Sulfuric Acid Solution (10 %)*—Carefully add 60 mL of concentrated sulfuric acid to 940 mL of water, slowly while stirring.

33.8 *Phenolphthalein Indicator Solution*, 1 %.

33.9 *Starch Indicator Solution*.

34. Procedure

34.1 Weigh to the nearest 0.0001 g, 70 to 80 mg of hydroxypropylcellulose, previously dried at 105°C for 1 h, into the reaction flask. Add 10 mL of water and swirl gently for 5 min. Then add 10 mL of chromium trioxide solution and assemble the apparatus as shown in Fig. 2.

34.2 Immerse the reaction flask in the oil bath slightly above the level of the chromium trioxide solution. Start the condenser cooling water, and pass nitrogen gas through the flask at a rate

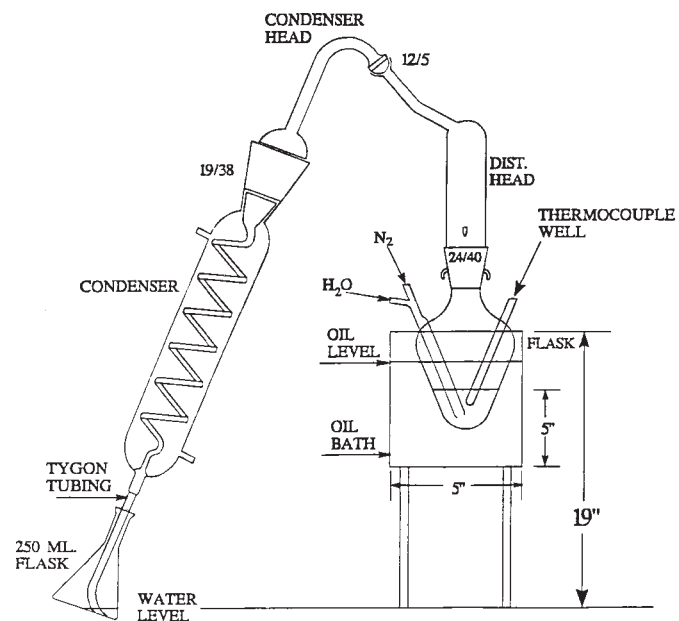

FIG. 2 Oxidation and Distillation Apparatus

⁶ References for the hydroxypropoxy determination are as follows: *United States Pharmacopeia XXII*, General Chapter (421), "Hydroxypropoxy Determination," 1990, p. 1537, *National Formulary XVII*, "Monograph for Hydroxypropyl Cellulose," 1990, p. 1938, United States Pharmacopeial Convention, Inc., 12601 Twinbrook Parkway, Rockville, MD 20852.

⁷ Hercules Test Method No. K45-3, "Kluacel® Molecular Substitution," Hercules Test Method No. M100-53, "Terminal Methyl Groups (Chromic Acid Oxidation)," available from Hercules, Inc. c/o Aqualon Co., P.O. Box 271, Hopewell, VA 23860-5245.

of 70 to 75 mL/minute. Raise the temperature of the oil bath to 155°C over a 30-min time period, and maintain it at that temperature throughout the determination. Too rapid an initial rise in temperature results in high blanks.

34.3 Monitor the temperature of the reaction mixture using a thermocouple or thermometer in a well as shown in Fig. 2. When the temperature of the reaction mixture reaches 101 to 103°C, add water through the water inlet until the temperature drops to 96 to 98°C. Continue this cycle until 100 mL of distillate has been collected. Detach the condenser from the distillation head and wash with water, collecting the washings in the flask containing the distillate.

34.4 Add 2 or 3 drops of phenolphthalein indicator solution to the distillate and titrate with 0.02 *N* sodium hydroxide solution until a pink color persists momentarily. Place the flask on a hot plate, boil for one minute, cool, and continue the titration to a pink color which persists for 10 s. Record the total volume of sodium hydroxide solution used, *A*.

34.5 Add 0.5 g of sodium bicarbonate to the flask and swirl to mix. Then add 10 mL of sulfuric acid solution (10 %), swirl, and allow to stand until carbon dioxide evolution ceases. Add 1 g of potassium iodide, stopper, and mix well to dissolve. Allow the solution to stand in the dark for 5 min. Titrate the liberated iodine with 0.02 *N* sodium thiosulfate solution, adding starch indicator near the end point. Record the total volume of sodium thiosulfate solution used, *B*.

34.6 *Empirical Factor, K*—The empirical factor, *K*, for each apparatus is obtained by running a blank determination in which the hydroxypropylcellulose is omitted.

35. Calculations

35.1 The empirical factor, *K*, is calculated as follows:

$$K = \frac{\text{mL NaOH for the blank} \times N}{\text{mL Na}_2\text{S}_2\text{O}_3 \text{ for the blank} \times N'} \quad (7)$$

where:

N = normality of the 0.02 *N* NaOH solution, mL, and
N' = normality of the 0.02 *N* Na₂S₂O₃ solution, mL.

35.2 The percent hydroxypropoxy, *HP*, is calculated as follows:

$$HP = \left(\frac{[(A \times N) - K(B \times N')] \times F}{W} \right) \times 100 \quad (8)$$

where:

A = volume of NaOH solution used, mL,
N = normality of the 0.02 *N* NaOH solution,
K = empirical factor,
B = volume of Na₂S₂O₃ solution used, mL,
N' = normality of the 0.02 *N* Na₂S₂O₃ solution,
W = sample used, g, and
F = molecular weight of group determined/1000 × recovery

Recovery for propylene glycol was found to be 0.95 and the molecular weight of the hydroxypropoxy group is 75. Therefore, *F* = 0.079 in this case.

36. Precision and Bias

36.1 *Precision*—Statistical analysis of intralaboratory test results on samples containing 65 to 80 % hydroxypropoxy content indicates a precision of ±15 % at the 95 % confidence level.

36.2 *Bias*—No justifiable statement on bias can be made as no suitable reference material is available as a standard.

37. Keywords

37.1 hydroxypropoxy content; hydroxypropylcellulose; moisture; pH; residue on ignition; viscosity

ASTM International takes no position respecting the validity of any patent rights asserted in connection with any item mentioned in this standard. Users of this standard are expressly advised that determination of the validity of any such patent rights, and the risk of infringement of such rights, are entirely their own responsibility.

This standard is subject to revision at any time by the responsible technical committee and must be reviewed every five years and if not revised, either reapproved or withdrawn. Your comments are invited either for revision of this standard or for additional standards and should be addressed to ASTM International Headquarters. Your comments will receive careful consideration at a meeting of the responsible technical committee, which you may attend. If you feel that your comments have not received a fair hearing you should make your views known to the ASTM Committee on Standards, at the address shown below.

This standard is copyrighted by ASTM International, 100 Barr Harbor Drive, PO Box C700, West Conshohocken, PA 19428-2959, United States. Individual reprints (single or multiple copies) of this standard may be obtained by contacting ASTM at the above address or at 610-832-9585 (phone), 610-832-9555 (fax), or service@astm.org (e-mail); or through the ASTM website (www.astm.org).