



Standard Practice for Evaluating and Comparing Transfer Efficiency of Spray Applied Coatings Under General Laboratory Conditions¹

This standard is issued under the fixed designation D 5327; the number immediately following the designation indicates the year of original adoption or, in the case of revision, the year of last revision. A number in parentheses indicates the year of last reapproval. A superscript epsilon (ϵ) indicates an editorial change since the last revision or reapproval.

1. Scope

1.1 This practice covers the evaluation and comparison of the transfer efficiency of spray-applied coatings under general laboratory conditions. Transfer efficiency is the ratio of paint solids deposited to the total paint solids used during the application process, expressed as a percent. This practice can be used to study the effect on transfer efficiency of changing operating variables and paint formulations. Key variables that need to be controlled are listed in 8.13.

NOTE 1—It is important that all process or formulation parameters, except that which is intentionally being changed, be kept consistent from test to test. If not done, the results of the study are to be questioned.

1.2 The reproducibility of this practice is highly dependent on the degree of control of the parameters listed in Section 8 of the practice.

1.3 *Limitations*—This laboratory practice indicates only the direction of the effect of operating variables and liquid paint formulations on transfer efficiency under conditions of the laboratory test: the magnitude of the effect can be determined only with specific plant experience. In fact, the nature of the critical parameters that affect transfer efficiency makes clear that it is not possible to extrapolate laboratory results.

NOTE 2—The laboratory practice outlined involves general laboratory spray equipment and procedures and is derived from Test Method D 5009. This practice and Test Method D 5009 are both derived from a study and report of transfer efficiency measurements conducted for the U.S. Environmental Protection Agency. For laboratories that have access to a conveyor and mass flow measurement equipment, a suitable, potentially more reproducible, tested method is defined in Test Method D 5009.

1.4 The values stated in SI units are to be regarded as the standard. The values given in parentheses are for information only.

1.5 *This standard does not purport to address all of the safety concerns, if any, associated with its use. It is the responsibility of the user of this standard to establish appro-*

priate safety and health practices and determine the applicability of regulatory limitations prior to use. For specific hazard statements see Section 7, Note 8 and Note 9.

2. Referenced Documents

2.1 ASTM Standards:

D 1200 Test Method for Viscosity by Ford Viscosity Cup²

D 2369 Test Method for Volatile Content of Coatings²

D 3925 Practice for Sampling Liquid Paints and Related Pigmented Coatings²

D 5009 Test Method for Evaluating and Comparing Transfer Efficiency of Spray Applied Coatings Under Laboratory Conditions³

2.2 Other Standards:

NFPA 33 Spray Application Using Flammable and Combustible Materials⁴

NFPA 86 Standard for Ovens and Furnaces⁴

3. Terminology

3.1 Definitions of Terms Specific to This Practice:

3.1.1 *fluid mass flow rate*—the mass flow rate of paint in grams per minute during the test.

3.1.2 *mass of foil*—the weight of each target foil in grams before being painted.

3.1.3 *mass of foil plus paint solids*—the weight of each target foil in grams after being painted and baked.

3.1.4 *mass of paint solids*—the difference in the mass of the foil before painting and the mass of the foil after painting and baking. The sum of the mass of the foil plus paint solids less the sum of the mass of the foil.

3.1.5 *transfer efficiency*—the ratio of the mass of the paint solids deposited on the foil to the mass of the paint solids sprayed during the test, expressed as a percent.

3.1.6 *weight percent solids*—the solids content as percent of the total weight of a sample of the paint used during the test.

3.1.6.1 *Discussion*—Weight percent solids are determined as specified in 8.4.2.

¹ This practice is under the jurisdiction of ASTM Committee D01 on Paint and Related Coatings, Materials, and Applications and is the direct responsibility of Subcommittee D01.55 on Factory Applied Coatings on Preformed Products.

Current edition approved June 10, 1997. Published September 1997. Originally published as D 5327 – 92. Last previous edition D 5327 – 92.

² *Annual Book of ASTM Standards*, Vol 06.01.

³ *Annual Book of ASTM Standards*, Vol 06.02.

⁴ Available from National Fire Protection Association (NFPA), 1 Batterymarch Park, Quincy, MA 02269-9101.

4. Summary of Practice

4.1 Metal panels covered with preweighed aluminum foil are coated in a spray booth. The coated foils are baked to remove volatile matter. The transfer efficiency is calculated on a weight percent basis using the solids content, quantity of paint sprayed, and the amount of solids on the coated aluminum foil.

5. Significance and Use

5.1 Subject to the limitations listed in 1.3, this practice can be used as a research tool to optimize spray equipment and paint formulations, as well as to study the relative effect on transfer efficiency of changing operating variables, spray application equipment, type of coatings, etc.

6. Apparatus

6.1 *Laboratory Scale*, accurate to ± 0.001 g.

6.2 *Platform Scale*, accurate to ± 0.01 g.

6.3 *Targets*, should consist of a minimum of three steel panels, two scavengers and a target panel. If more than one target panel is used, a scavenger panel is to be used at the start and end of the test panel set. The steel panels are 15.2 by 0.15875 cm wide (6 by 0.0625 in.) with 0.635 cm (0.25 in.) radius corners. The length of the panel should be sufficient that a minimum of 30.4 cm (12 in.) above and below the spray pattern is achieved.

NOTE 3—It is essential to effectively capture the entire height of the spray pattern.

NOTE 4—Other panel sizes similar to those in the end use can be used. Differences in the part shape will influence the transfer efficiency.

NOTE 5—Results of this test may not be extrapolated to different spray booths, part geometries, etc.

6.4 *Aluminum Foil*, medium temper or equivalent, 0.0037-cm (1.5-mil) thick. The aluminum foil should be preheated at the conditions specified in the cure schedule recommended by the paint manufacturer.

6.5 *Back-Draw Water-Wash Spray Booth*, or equivalent. The booth should be capable of developing and maintaining up to 36.58 m/min (120 ft/min) air velocity in the middle at the plane of the target. If a filter booth is used, filters should be changed as frequently as necessary to maintain uniform air velocity.

6.6 *Forced Draft Curing Oven*, if required, of sufficient size for curing targets, capable of achieving and maintaining the cure temperature specified by the paint supplier. All ovens should conform to NFPA 86.

6.7 *Curing Rack*.

6.8 *Stopwatch*.

6.9 *Air Velocity Measurement Equipment*.

6.10 *Humidity and Temperature Measurement Equipment*.

6.11 *Compressed Air Supply*.

6.12 *Spray Gun*.

NOTE 6—The spray gun can be attached to a spray machine or hand held. Needless to say, operator variation with a hand held spray gun can mask the effect of changes in the variable being studied.

7. Hazards

7.1 For specific hazard information and guidance, consult the supplier's Material Safety Data Sheet (MSDS) for the materials used.

8. Procedure

8.1 Set up the paint supply equipment to the spray apparatus in accordance with the manufacturer's instructions.

8.1.1 Ground all electrically conductive objects in the spray area, except those objects required by the process to be at high voltage in accordance with Chapter 9.11 of NFPA 33.

8.2 Agitate the test paint in a closed container at least 30 min before paint samples are taken.

8.3 Using an airtight container, take a paint grab sample from the paint pot in accordance with Practice D 3925.

8.4 Determine and record the following from the paint sample:

8.4.1 Paint viscosity in accordance with Test Method D 1200,

8.4.2 *Weight Percent Solids*—The preferred method is Test Method D 2369. If the baking temperature in Test Method D 2369 is considered inadequate for complete cure, use the manufacturer's recommended cure schedule. Make sure that the cure schedule used is agreed upon and recorded, and

8.4.3 Electrical resistivity for samples being applied electrostatically.

8.5 Cut the aluminum foil to dimensions of 58 by 5 cm (15 by approximately 2 in.) longer than the length of the target panel.

8.6 Number each precut foil strip, before weighing, using a permanent marking pen.

8.7 Weigh each test foil strip and record the uncoated weight and the foil number.

8.8 Attach the preweighed, labeled test foil to the targets using the technique shown in Fig. 1.

8.9 Mount the foil covered targets on a panel or target holder, with the foil seam on each target facing away from the spray gun. Set panel spacing as desired.

8.9.1 If electrostatic equipment is being used, the resistance shall be less than 1 by $10^6 \Omega$ between the target and earth ground, in accordance with Chapter 9.8 of NFPA 33.

8.10 Adjust the following equipment operating parameters, as appropriate, to the values desired for testing:

8.10.1 Paint fluid pressure at spray gun, kPa (psi),

8.10.2 Atomizing air pressure at spray gun, kPa (psi),

8.10.3 Rotating atomizer head speed (revolutions per minute) with and without paint fluid flow,

8.10.4 Operating voltage if electrostatic equipment is used, kV,

8.10.5 Ambient air temperature ($^{\circ}\text{C}$),

8.10.6 Paint fluid temperature ($^{\circ}\text{C}$),

8.10.7 Booth air velocity, feet per minute (meters per minute),

8.10.8 Relative humidity (percent),

8.10.9 Spray machine variables or spray gun procedures when using a hand held spray gun,

NOTE 7—The spray gun can be attached to a spray machine or hand held. If hand held, variations in technique can effect reproducibility of the transfer efficiency study and may override comparisons made.

8.10.10 Set the following variables where applicable (see Note 8):

8.10.10.1 Spray gun to target distance, cm (in.),

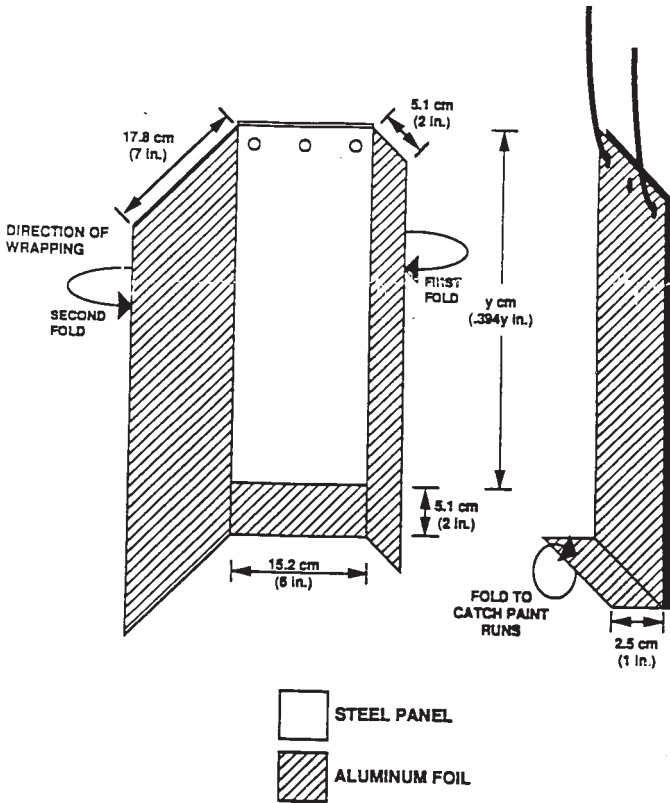

NOTE 1—Scale: Not To Scale. For y see 6.3 for dimensions.

FIG. 1 Foil Attachment Technique

- 8.10.10.2 Travel speed, centimetres per minute (inches per minute),
- 8.10.10.3 Number of coats,
- 8.10.10.4 Number of passes per coat, and
- 8.10.10.5 Flash between coats, seconds.

NOTE 8—**Precaution:** If electrostatic equipment is being used, the gun-to-target distance shall be at least twice the sparking distance in accordance with Chapter 9.7 NFPA 33, where applicable.

8.10.11 Set the cure time and temperature in accordance with the manufacturer’s instructions.

8.11 For electrostatic spray equipment, measure the operating voltage, and adjust it according to the manufacturer’s instructions.

8.12 Turn on the spray booth. Turn on paint spray equipment. Maintain uniform paint flow during the test. Turn off spray equipment.

8.13 Weigh the paint before and after the test.

8.13.1 If the weight difference measurement approach is not appropriate, use the following technique: just after turning on the spray equipment, spray the unatomized paint into a preweighed plastic container for a minimum of 30 s.

NOTE 9—**Precaution:** Turn off all high voltage to electrostatic spray guns to prevent personal injury.

8.13.2 Immediately weigh the container with paint, calculate the flow rate, and record the result. Before turning off the spray machine, repeat this procedure. Average the two results to obtain the average flow rate for the test.

NOTE 10—The use of a gallon plastic bottle with the top cut off to conveniently fit around the front of the gun is recommended. A large plastic beaker covered with plastic wrap with a hole punched in the center of the plastic wrap may also be used. Turn off all air sources to the spray gun before using this procedure to prevent paint splatter out of the container.

8.14 Record the following data:

8.14.1 *Application Equipment:*

- 8.14.1.1 Paint fluid pressure at the spray gun, psi (kPa),
- 8.14.1.2 Atomizing air pressure at spray gun, psi (kPa),
- 8.14.1.3 Rotating atomizer head speed (revolutions per minute) with and without paint fluid flow,
- 8.14.1.4 Spray machine settings,
- 8.14.1.5 Operating voltage at the electrode tip if electrostatic equipment is used, kV,

NOTE 11—If a hand held spray gun is used, record the gun-to-panel distance, number of coats, and the flash time between coats.

- 8.14.1.6 Panel spacing, and
- 8.14.1.7 Spray time.

8.14.2 *Spray Booth Variables:*

- 8.14.2.1 Ambient temperature (°C),
- 8.14.2.2 Paint fluid temperature (°C),
- 8.14.2.3 Booth air velocity, feet per minute (meters per minute),

NOTE 12—Variations in booth air velocity can affect transfer efficiency results.

- 8.14.2.4 Relative humidity (percent), and
- 8.14.2.5 Mass of paint used for painting the targets, grams (pounds).

NOTE 13—The mass of paint used may be determined by measuring the difference in weight of the paint before and after the sprayout or by multiplying the paint flow rate determined in 8.13.2 by the length of time that the spray equipment is on.

8.14.3 Operator name and date.

8.15 After the paint flow is topped, carefully remove the painted targets from the panel holder to ensure that no paint is lost.

8.16 For products that are baked, hang the coated targets on oven racks so all painted surfaces are exposed for uniform drying. Flash per the manufacturer’s recommendations, insert the racks into the oven and bake using the manufacturer’s recommended cure schedule. For products that are not baked, follow the manufacturer’s recommended cure schedule.

8.17 Where appropriate, remove the targets from the oven and let cool.

8.18 Remove the foil from each target, weigh and record the coated weight, the foil number, the dry film thickness at the center of the spray pattern, and the percent vertical film coverage. If the desired dry film thickness and the percent vertical film coverage is not achieved, repeat the procedure listed in 8.1-8.17.

8.19 The mass of the paint solids deposited is the difference between the weight of the foil after painting and baking, and the total weight of the foil before painting.

9. Calculation

9.1 Calculate the transfer efficiency using the following equation:



$$T = 100 P / (W \times A)$$

(1)

where:

- T = transfer efficiency, %
- P = mass of paint solids deposited, as specified in 8.19,
- W = weight percent solids expressed as a decimal as specified in 8.4.2, and
- A = mass of paint applied, as specified in 8.13, 8.13.1, or 8.13.2.

- 10.1.2 Type of spray equipment,
- 10.1.3 Type of paint applied,
- 10.1.4 Paint application conditions as listed in 8.13, and
- 10.1.5 Conditions of test other than those specified in the procedure section of this practice.

11. Keywords

- 11.1 general laboratory method; laboratory practice; spray-applied coatings; transfer efficiency

10. Report

10.1 Report the following information:

10.1.1 Transfer efficiency results,

ASTM International takes no position respecting the validity of any patent rights asserted in connection with any item mentioned in this standard. Users of this standard are expressly advised that determination of the validity of any such patent rights, and the risk of infringement of such rights, are entirely their own responsibility.

This standard is subject to revision at any time by the responsible technical committee and must be reviewed every five years and if not revised, either reapproved or withdrawn. Your comments are invited either for revision of this standard or for additional standards and should be addressed to ASTM International Headquarters. Your comments will receive careful consideration at a meeting of the responsible technical committee, which you may attend. If you feel that your comments have not received a fair hearing you should make your views known to the ASTM Committee on Standards, at the address shown below.

This standard is copyrighted by ASTM International, 100 Barr Harbor Drive, PO Box C700, West Conshohocken, PA 19428-2959, United States. Individual reprints (single or multiple copies) of this standard may be obtained by contacting ASTM at the above address or at 610-832-9585 (phone), 610-832-9555 (fax), or service@astm.org (e-mail); or through the ASTM website (www.astm.org).