



Designation: D 524 – 03

An American National Standard
British Standard 4451



Designation: 14/94

Standard Test Method for Ramsbottom Carbon Residue of Petroleum Products¹

This standard is issued under the fixed designation D 524; the number immediately following the designation indicates the year of original adoption or, in the case of revision, the year of last revision. A number in parentheses indicates the year of last reapproval. A superscript epsilon (ϵ) indicates an editorial change since the last revision or reapproval.

This standard has been approved for use by agencies of the Department of Defense.

1. Scope*

1.1 This test method covers the determination of the amount of carbon residue (Note 1) left after evaporation and pyrolysis of an oil, and it is intended to provide some indication of relative coke-forming propensity. This test method is generally applicable to relatively nonvolatile petroleum products which partially decompose on distillation at atmospheric pressure. This test method also covers the determination of carbon residue on 10% (V/V) distillation residues (see Section 10). Petroleum products containing ash-forming constituents as determined by Test Method D 482, will have an erroneously high carbon residue, depending upon the amount of ash formed (Notes 2 and 3).

NOTE 1—The term *carbon residue* is used throughout this test method to designate the carbonaceous residue formed during evaporation and pyrolysis of a petroleum product. The residue is not composed entirely of carbon, but is a coke which can be further changed by pyrolysis. The term *carbon residue* is continued in this test method only in deference to its wide common usage.

NOTE 2—Values obtained by this test method are not numerically the same as those obtained by Test Method D 189, or Test Method D 4530. Approximate correlations have been derived (see Fig. X2.1) but need not apply to all materials which can be tested because the carbon residue test is applicable to a wide variety of petroleum products. The Ramsbottom Carbon Residue test method is limited to those samples that are mobile below 90°C.

NOTE 3—In diesel fuel, the presence of alkyl nitrates such as amyl nitrate, hexyl nitrate, or octyl nitrate, causes a higher carbon residue value than observed in untreated fuel, which can lead to erroneous conclusions as to the coke-forming propensity of the fuel. The presence of alkyl nitrate in the fuel can be detected by Test Method D 4046.

NOTE 4—The test procedure in Section 10 is being modified to allow the use of a 100-mL volume automated distillation apparatus. No precision data is available for the procedure at this time, but a round robin is being planned to develop precision data. The 250-mL volume bulb

distillation method described in Section 10 for determining carbon residue on a 10 % distillation residue is considered the referee test.

1.2 *This standard does not purport to address all of the safety concerns, if any, associated with its use. It is the responsibility of the user of this standard to establish appropriate safety and health practices and determine the applicability of regulatory limitations prior to use.*

2. Referenced Documents

2.1 ASTM Standards:

- D 86 Test Method for Distillation of Petroleum Products at Atmospheric Pressure²
- D 189 Test Method for Conradson Carbon Residue of Petroleum Products²
- D 482 Test Method for Ash from Petroleum Products²
- D 4046 Test Method for Alkyl Nitrate in Diesel Fuels by Spectrophotometry³
- D 4057 Practice for Manual Sampling of Petroleum and Petroleum Products³
- D 4175 Terminology Relating to Petroleum, Petroleum Products, and Lubricants³
- D 4177 Practice for Automatic Sampling of Petroleum and Petroleum Products³
- D 4530 Test Method for Determination of Carbon Residue (Micro Method)³
- E 1 Specification for ASTM Thermometers⁴
- E 133 Specification for Distillation Equipment⁵

2.2 IP Standards:

- Appendix AP-A Specifications—IP Thermometers⁶

3. Terminology

3.1 Definitions:

3.1.1 *carbon residue, n*—the residue formed by evaporation and thermal degradation of a carbon containing material.

¹ This test method is under the jurisdiction of ASTM Committee D02 on Petroleum Products and Lubricants and is the direct responsibility of Subcommittee D02.06 on Analysis of Lubricants.

Current edition approved Sept. 10, 2003. Published September 2003. Originally approved in 1939. Last previous edition approved in 2000 as D 524–00^{ε1}.

In the IP, this test method is under the jurisdiction of the Standardization Committee.

² *Annual Book of ASTM Standards*, Vol 05.01.

³ *Annual Book of ASTM Standards*, Vol 05.02.

⁴ *Annual Book of ASTM Standards*, Vol 14.03.

⁵ *Annual Book of ASTM Standards*, Vol 14.02.

⁶ *IP Standard Methods for Analysis and Testing of Petroleum and Related Products*, 1998. Available from Institute of Petroleum (IP), 61 New Cavendish St., London, W1G 7AR, U.K.

*A Summary of Changes section appears at the end of this standard.

D 4175

3.1.1.1 *Discussion*—The residue is not composed entirely of carbon but is a coke that can be further changed by carbon pyrolysis. The term carbon residue is retained in deference to its wide common usage.

4. Summary of Test Method

4.1 The sample, after being weighed into a special glass bulb having a capillary opening, is placed in a metal furnace maintained at approximately 550°C. The sample is thus quickly heated to the point at which all volatile matter is evaporated out of the bulb with or without decomposition while the heavier residue remaining in the bulb undergoes cracking and coking reactions. In the latter portion of the heating period, the coke or carbon residue is subject to further slow decomposition or slight oxidation due to the possibility of breathing air into the bulb. After a specified heating period, the bulb is removed from the bath, cooled in a desiccator, and again weighed. The residue remaining is calculated as a percentage of the original sample, and reported as Ramsbottom carbon residue.

4.2 Provision is made for determining the proper operating characteristics of the furnace with a control bulb containing a thermocouple, which must give a specified time-temperature relationship.

5. Significance and Use

5.1 The carbon residue value of burner fuel serves as a rough approximation of the tendency of the fuel to form deposits in vaporizing pot-type and sleeve-type burners. Similarly, provided alkyl nitrates are absent (or if present, provided the test is performed on the base fuel without additive) the carbon residue of diesel fuel correlates approximately with combustion chamber deposits.

5.2 The carbon residue value of motor oil, while at one time regarded as indicative of the amount of carbonaceous deposits a motor oil would form in the combustion chamber of an engine, is now considered to be of doubtful significance due to the presence of additives in many oils. For example, an ash-forming detergent additive can increase the carbon residue value of an oil yet will generally reduce its tendency to form deposits.

5.3 The carbon residue value of gas oil is useful as a guide in the manufacture of gas from gas oil, while carbon residue values of crude oil residuum, cylinder and bright stocks, are useful in the manufacture of lubricants.

6. Apparatus

6.1 *Glass Coking Bulb*, of heat-resistant glass conforming to the dimensions and tolerances shown in Fig. 1. Prior to use, check the diameter of the capillary to see that the opening is greater than 1.5 and not more than 2.0 mm. Pass a 1.5-mm diameter drill rod through the capillary and into the bulb; attempt to pass a 2.0-mm diameter drill rod through the capillary. Reject bulbs that do not permit the insertion of the smaller rod and those whose capillaries are larger than the larger rod.

6.2 *Control Bulb*, stainless steel, containing a thermocouple and conforming to the dimensions and tolerances shown in Fig.

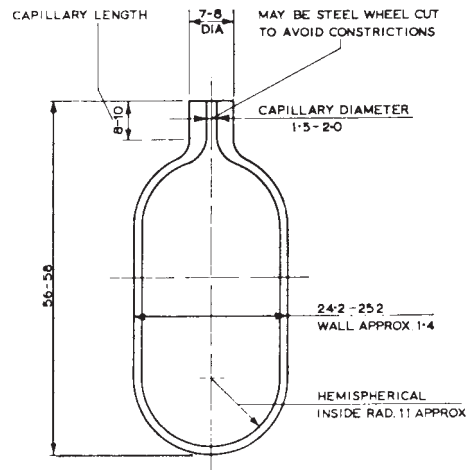

NOTE—All dimensions are in millimetres.

FIG. 1 Glass Coking Bulb

2, for use in determining compliance of furnace characteristics with the performance requirements (Section 7). The control bulb shall be provided with a dull finish, as specified in Fig. 2, and must not be polished thereafter. A polished bulb has different heating characteristics from one with a dull finish. A suitable thermocouple pyrometer for observing true temperature within $\pm 1^\circ\text{C}$ is also required.

6.3 *Sample Charging Syringe*, 5 or 10-mL glass hypodermic (Note 5), fitted with a No. 17 needle (1.5 mm in outside diameter) or No. 0 serum needle (1.45 to 1.47 mm in outside diameter) for transfer of the sample to the glass coking bulb.

NOTE 5—A syringe having a needle that fits on the ground-glass tip of the syringe is not recommended, as it may be blown off when pressure is applied to the syringe plunger. The Luer-Lok type syringes are more satisfactory, as the needle locks on the bottom of the syringe barrel, and cannot be blown off by pressure.

6.4 *Metal Coking Furnace* of solid metal, having coking bulb wells 25.45 ± 0.1 mm in internal diameter and 76 mm deep to the center of the well bottom, with suitable arrangements for heating to a uniform temperature of 550°C. The bottom of the well shall be hemispherical to accommodate the bottom of the glass coking bulb. Do not cast or otherwise form the furnace with unnecessary voids which will impede heat transfer. If a molten metal furnace is used, provide it with a suitable number of bulb wells, the internal dimensions of which correspond to the internal dimensions of holes in the solid metal furnace. The bulb wells shall be immersed in the molten metal to leave not more than 3 mm of the bulb well exposed above the molten metal at operating temperatures.

NOTE 6—Ramsbottom coke furnaces now in use can have dimensional differences from those given in 6.4; however, it is essential that new furnaces obtained after the adoption of this test method conform to the requirements outlined in 6.4. A description of one type of furnace which has been found to be satisfactory is given in Appendix X1.

6.5 *Temperature-Measuring Devices*—A removable iron-constantan thermocouple with a sensitive pyrometer, or other suitable temperature-indicating device, located centrally near the bottom portion of the furnace and arranged to measure the temperature of the furnace so that the performance tests

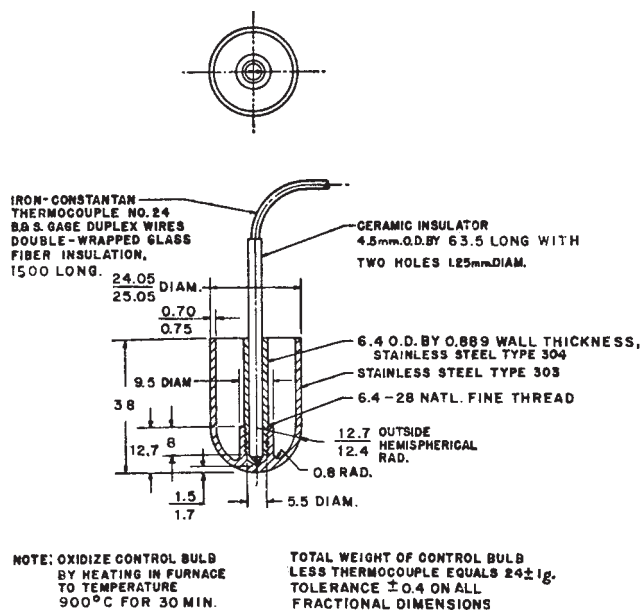

NOTE—All dimensions are in millimetres.

FIG. 2 Control Bulb

specified in Section 7 can be obtained. It is desirable to protect the temperature-indicating device with a quartz or thin metal sheath when a molten bath is used.

NOTE 7—It is good practice to calibrate the thermocouple or other temperature-measuring device against a standard thermocouple or reference standards about once a week, when the furnace is in constant use, the actual frequency depending on experience.

7. Checking Performance of Apparatus

7.1 Periodically check the performance of the furnace and temperature-measuring devices as described in 7.1.1-7.1.3 to make certain that as used they conform to the requirements of the method. Consider the furnace as having standard performance, and use it with any degree of loading, when the operating requirements described for each coking bulb well are met, while the bath is fully loaded as well as singly loaded. Use only a furnace that has successfully passed the performance or control tests given in this section.

7.1.1 *Thermocouple*—At least once every 50 h of use of the control bulb, calibrate the thermocouple in the control bulb against a standard thermocouple.

NOTE 8—In use at the high temperature of the test, iron-constantan thermocouples oxidize and their calibration curves change.

7.1.2 *Fully Loaded Furnace*—When the furnace temperature is within a previously chosen 2°C temperature range (which range is to be used thereafter with that particular furnace for both standardization and routine operation) and within the general range 550 ± 5°C, insert the control bulb in one well and, within 15 s, insert in each of the other wells a glass coking bulb containing 4 ± 0.1 g of a viscous neutral petroleum lubricating oil with a viscosity within the SAE 30 range or 60 to 100 mm²/s (cSt) at 40°C. With a suitably accurate potentiometer or millivoltmeter (sensitive to 1°C or less), observe the temperature rise in the control bulb at 1-min

intervals for 20 min. If the temperature in the control bulb reaches 547°C in not less than 4 and not more than 6 min from the instant of its insertion in the furnace, and remains within the range 550 ± 3°C for the remaining portion of the 20-min test, consider that particular coking bulb well suitable for use as a *standard performance well* when the furnace is used fully loaded. Inspect each well in similar fashion with the furnace fully loaded each time.

7.1.3 *Singly Loaded Furnace*—When the furnace temperature is within a previously chosen 2°C temperature range (which range is to be used thereafter with that particular furnace for both standardization and routine operation) and within the general range 550 ± 5°C, insert the control bulb in one well, with the remaining wells unoccupied. With a suitably accurate potentiometer or millivoltmeter (sensitive to 1°C or less), observe the temperature rise in the control bulb at 1-min intervals for 20 min. If the temperature in the control bulb reaches 547°C in not less than 4 and not more than 6 min from the instant of its insertion in the furnace, and remains within the range 550 ± 3°C for the remaining portion of the 20-min test, consider that particular coking bulb well suitable for use as a *standard performance well* when only a single test is made. Inspect each well in similar fashion with the furnace singly loaded each time.

NOTE 9—It is possible that not all of the wells in old furnaces will meet the requirements when fully loaded and singly loaded; and, when this is the case, inspect each well for any degree of furnace loading which may be used. For example, when not more than three wells of a six-well furnace can be used at any one time, the three wells to be used should be chosen from the performance data obtained with fully loaded and singly loaded furnaces. Then each of the three wells should be inspected for triple loading, two of the wells for double loading, and one for single loading. Use the wells tested and no others in applying the test procedure.

NOTE 10—In sampling oils containing sediment (for example, used oils), it is important to make the transfer of sample in the shortest possible time to avoid segregation of the sediment. Samples containing sediment which settles quickly after stirring can be placed in the coking bulbs more expeditiously by using an arrangement such as that shown in Fig. 3. This sampling device consists of a three-way 2-mm stopcock to which have been fused two lengths of capillary tubing (1.5 mm in inside diameter). Connect the third leg of the stopcock by means of pressure tubing to a vacuum line. Secure the glass coking bulb to the short arm of capillary tubing by a 25-mm length of rubber hose, taking care that the capillary of the glass bulb is butted up against the capillary tubing. Immerse the long end of the capillary tubing in the sample. After evacuating the coking bulb, manipulate the stopcock to cause the stirred sample to flow freely into the bulb through the two lengths of capillary tubing. It is necessary to use tubing with the same size capillary as that in the neck of the coking bulb to prevent accumulation of any sediment during transfer.

8. Sampling

8.1 For sampling techniques see Practice D 4057 or Practice D 4177.

9. Procedure

9.1 Place a new glass coking bulb (Note 12) in the coking furnace at 550°C for about 20 min to decompose any foreign organic matter and to remove water. Place in a closed desiccator over CaCl₂ for 20 to 30 min and then weigh to the nearest 0.1 mg.

NOTE 11—Do not reuse a glass coking bulb, as unpredictable results are

TABLE 1 Sample Sizes

Ramsbottom Carbon Residue, %	Sample Size, g
Less than 6.0	4.0 ± 0.1
6.0 to 14.0	1.0 ± 0.1
14.1 to 20.0	0.5 ± 0.1

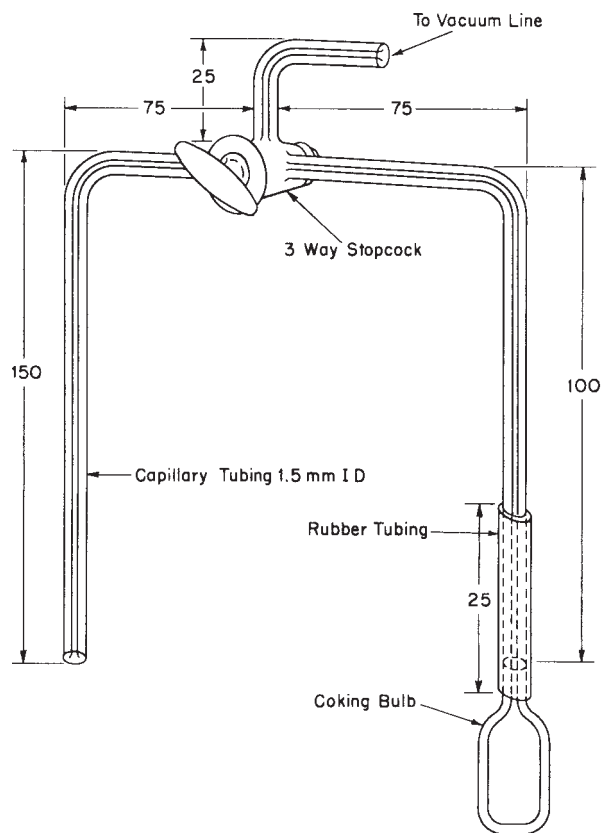

NOTE—All dimensions are in millimetres (1 in. = 25 mm).
FIG. 3 Sampling Device

sometimes obtained in such cases. For routine testing, new bulbs can be used without pre-ignition provided they are visibly free from particles or other contamination. Such bulbs, at least, should be heated in an oven to 150°C, placed in a desiccator, and then weighed.

NOTE 12—On making a test, it is important to adhere rigorously to the temperature conditions chosen for Section 7; for example, if the bath was at a temperature of 553 ± 1°C when inserting the control bulb, then it is necessary to use similar temperature conditions in the coking test. When maintained in normal operation, the temperature of an electrically heated furnace with automatic controls will generally fluctuate within a specific temperature range. Therefore, when making a coking test, it is generally important that the test bulbs be inserted when the furnace is at the same temperature or at the same position in the temperature cycle as it was when the inspection test was started, unless it has been proven that the temperature variations are inappreciable.

9.2 Shake thoroughly the sample to be tested, first heating to 50° ± 10°C for 0.5 h when necessary to reduce its viscosity. Immediately following the heating and shaking, strain the sample through a 100-mesh wire screen. By means of a hypodermic syringe or the device shown in Fig. 3 introduce into the coking bulb an amount of sample as indicated in Table 1. Make sure that no oil remains on the exterior surface or on the inside of the neck of the bulb. Reweigh the bulb and contents to the nearest milligram. If the sample foams or spatters, repeat the test using the next smaller sample size listed in Table 1. In reporting the results, include the size when such small samples are used. If difficulty is encountered in loading very viscous or asphaltic samples of any size into the glass coking bulb, the apparatus shown in Fig. X1.2 can be used.

9.3 Place the coking bulb in a *standard performance well* with the furnace at the checking temperature (Note 12), and allow to remain for 20 ± 2 min. Remove the bulb with metal tongs, the tips of which have just been heated. Duplicate the furnace and bulb conditions used when standardizing that bulb well (Section 7 and Note 9). If there is appreciable loss of oil from frothing, discard the test and repeat the determination using a smaller sample (Note 13).

NOTE 13—Frothing can be due to water which can be removed by heating gently in a vacuum and sweeping out the vapor with nitrogen prior to filling the bulb.

9.4 After removal, cool the bulb in a desiccator under the same conditions (including time for weighing) used before filling the bulb (9.2). When removing the bulb from the desiccator, examine it to make sure there are no foreign particles adhering to the bulb; if any are found, as black particles sometimes are on the capillary neck, brush them off with a piece of sized paper or camel's hair brush. Weigh to the nearest 0.1 mg. Discard the used glass coking bulb.

NOTE 14—In studies of oil characteristics, useful information can often be gleaned from a simple visual examination of the coking bulb after the test. Thus, significance can be attached to noting, with the results, such findings as: coke more or less fills the bulb; liquid material is present, either as limpid residue or drops; the residue is not black and flaky, but is colored and pulverulent (presumably from presence of inorganic materials).

10. Procedure for Carbon Residue on 10 % (V/V) Distillation Residue

10.1 This procedure is applicable to middle distillate materials, such as ASTM No. 1 and No. 2 fuel oils.

10.2 A distillation analysis using either a 100 or 200-mL starting volume is required in order to collect a sufficient amount of the 10 % (V/V) residue needed in this analysis. For a 100-mL distillation, assemble the distillation apparatus described in either Test Method D 86 or Specification E 133. Use a distillation flask with a 125-mL bulb volume, a flask support board with a 50-mm diameter opening, and a graduated cylinder with a 100-mL capacity. For a 200-mL distillation, assemble the distillation apparatus described in Specification E 133, using flask D (250-mL bulb volume), flask support board with 50-mm diameter opening, and graduated cylinder C (200-mL capacity). A thermometer is not required, but the use of the ASTM High Distillation Thermometer 8F or 8C, as prescribed in Specification E 1, or the IP High Distillation Thermometer 6C, as prescribed in Specifications—IP Thermometers, is recommended.

10.3 Depending upon which distillation flask is used, place either 100 or 200 mL of sample (as measured at ambient temperature) into the distillation flask that is held at a temperature between 13°C and ambient. Maintain the condenser bath

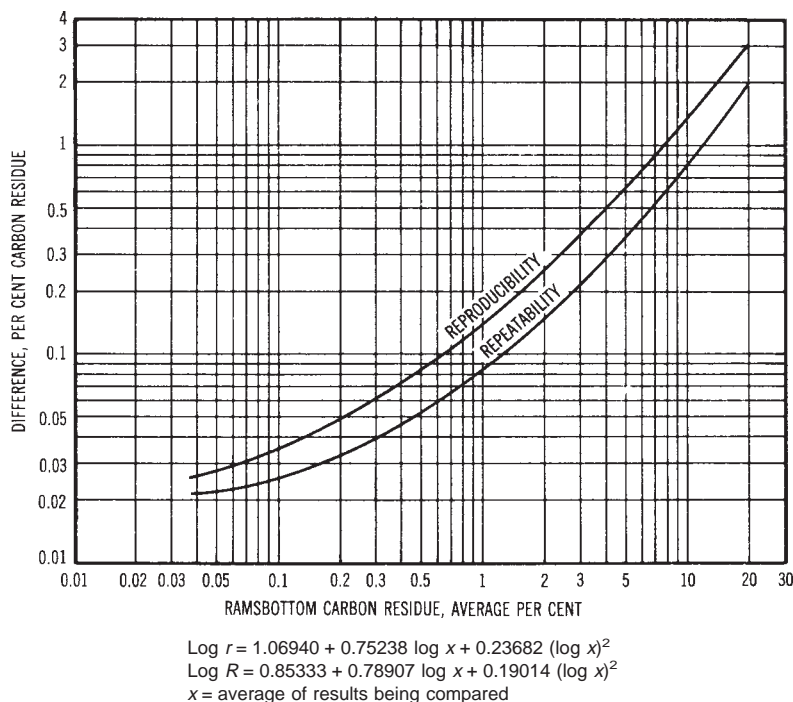

FIG. 4 Precision Data

temperature between 0 and 60°C to provide a sufficient temperature differential for sample condensation. Avoid any solidification of waxy material in the condenser tube. Place, without cleaning, the cylinder which was used to measure the sample under the condenser tube so that the tip of the condenser does not touch the wall of the cylinder. The receiver temperature shall be maintained at the same temperature (within ± 3°C) as when the sample was taken at the start of the test in order to obtain an accurate volume measurement in the receiving flask.

10.4 Apply the heat to the flask at a uniform rate so regulated that the first drop of condensate exits from the condenser between 10 and 15 min (for 200-mL samples) or between 5 and 15 min (for 100-mL samples) after initial application of heat. If a receiving cylinder deflector is not being used, immediately move the receiving cylinder so that the tip of the condenser tube touches the inner wall of the cylinder after the first drop falls. Then regulate the heat so that the distillation proceeds at a uniform rate of 8 to 10 mL/min (for 200-mL samples) or 4 to 5 mL/min (for 100-mL samples). For 200-mL samples, continue the distillation until approximately 178 mL of distillate has been collected, and then discontinue heating and allow the condenser to drain until 180 mL (90 % (V/V) of the charge to the flask) has been collected in the cylinder. For 100-mL samples, continue the distillation until approximately 88 mL of distillate has been collected, and then discontinue heating and allow the condenser to drain until 90 mL (90 % V/V) of the charge to the flask) has been collected in the cylinder.

10.5 Catch final drainage, if any, by immediately replacing the cylinder with a suitable container, such as a small Erlenmeyer flask. Add to this container, while still warm, the distillation residue left in the distilling flask, and mix well. The

contents of the container then represents a 10 % (V/V) distillation residue from the original product.

10.6 While the distillation residue is warm enough to flow freely, place 4.0 ± 0.1 g of it into the previously weighed coking bulb. A hypodermic syringe provides a convenient means of performing this operation. After cooling, weigh the bulb and contents to the nearest 1 mg, and carry out the carbon residue test in accordance with the procedure described in Section 9.

10.7 Report the percentage of carbon residue as the *Ramsbottom* carbon residue on 10 % distillation residue.

11. Calculation and Report

11.1 Calculate the carbon residue of the sample or of the 10 % distillation residue as follows:

$$\text{Carbon residue} = (A \times 100)/W \quad (1)$$

where:

A = mass of carbon residue, g, and
 W = mass of sample, g.

11.2 Report the value obtained as *Ramsbottom carbon residue, percent* or as *Ramsbottom carbon residue on 10 % distillation residue, percent*.

12. Precision and Bias ⁷

12.1 The precision of this test method as determined by statistical examination of interlaboratory results is as follows:

12.1.1 *Repeatability*—The difference between two test results, obtained by the same operator with the same apparatus

⁷ Supporting data have been filed at ASTM International Headquarters and may be obtained by requesting Research Report RR: D02-1228.

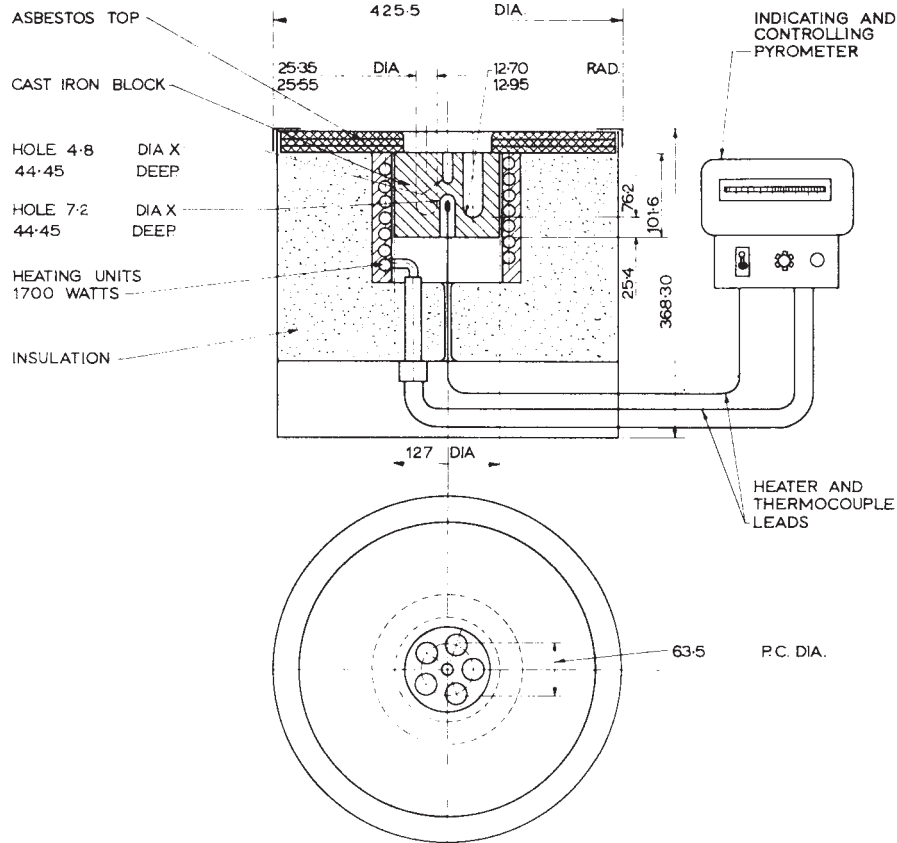

FIG. X1.1 Solid Metal Furnace

under constant operating conditions on identical test material would, in the long run, in the normal and correct operation of the test method, exceed the values shown in Fig. 4 only in one case in twenty.

12.1.2 *Reproducibility*—The difference between two single and independent results obtained by different operators working in different laboratories on identical test material would, in the long run, in the normal and correct operation of the test method, exceed the values shown in Fig. 4 only in one case in twenty.

NOTE 15—Precision is based on data developed using inch-pound units. See Test Method D 524.

12.2 *Bias*—This test method is empirical and no statement of bias can be made.

13. Keywords

13.1 carbon residue; petroleum products; Ramsbottom

APPENDIXES

(Nonmandatory Information)

X1. RAMSBOTTOM COKING FURNACE

X1.1 The greatest difficulty in achieving satisfactory precision for this test method is to obtain a uniformly operating furnace. The type of furnace described below meets the performance characteristics prescribed in Section 7.

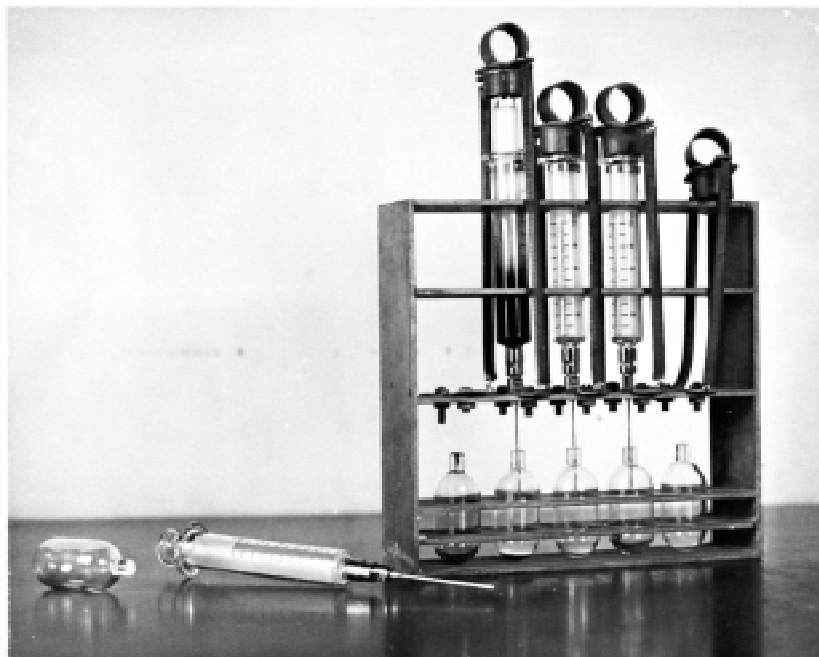

FIG. X1.2 Coking Bulb Filling Device

X1.2 *Solid Metal Furnace*⁸—A solid metal furnace can be constructed as illustrated in Fig. X1.1. It can be constructed of cast iron or other suitable metal for use under the high-temperature conditions which are employed in this test method. It is desirable to cast the metal without any unnecessary voids. Use of a substantial mass of metal for the block avoids the requirement for an excessive amount of electrical heating which could cause wide fluctuations in block temperature unless very sensitive controls were used.

X1.3 *Coking Bulb Filling Device*—The glass coking bulb filling device as shown in Fig. X1.2 has been found satisfactory for use with any mobile liquids that are too viscous to be handled at room temperature. The illustrated stand is made of

3 mm brass plate and constructed to hold five 10-mL syringes. For convenience, the stand can be modified to hold any number of syringes of either the 5 or 10-mL type.

X1.3.1 Warm the sample to be tested until it is fluid, place a coking bulb in position under the syringe and remove the plunger of the syringe from the barrel. Pour a representative portion of the sample into the barrel of the syringe, lubricate the plunger with one or two drops of white oil and replace in the barrel. Then place the loaded syringe in the rack as shown, with the spring-loaded clip fitted over the plunger head and with the tip of the needle extending into the bulb. Place the entire assembly in an oven maintained at the lowest temperature that will permit the sample to flow sufficiently to load the bulb.

X1.3.2 As soon as sufficient sample has been forced into the coking bulb, remove and weigh the bulb and its contents and proceed as described in 9.3. Remove the assembled apparatus from the oven as soon as possible as extended heating periods may alter the carbon residue value of the sample.

⁸ The sole source of supply of the apparatus known to the committee at this time is Precision Scientific Co., 3737 W. Cortland St., Chicago, IL 60647. If you are aware of alternative suppliers, please provide this information to ASTM Headquarters. Your comments will receive careful consideration at a meeting of the responsible technical committee,¹ which you may attend.

X2. INFORMATION CONCERNING CORRELATION OF CARBON RESIDUE RESULTS DETERMINED BY TEST METHODS D 189 AND D 524

X2.1 No exact correlation of the results obtained by the two test methods exists because of the empirical nature of the two tests. However, an approximate correlation (Fig. X2.1) has been derived from the cooperative testing by ASTM Committee D02 of 18 representative petroleum products and confirmed by further data on about 150 samples which were not tested

cooperatively. Test results by both test methods on unusual types of petroleum products may not fall near the correlation line of Fig. X2.1.

X2.2 Caution should be exercised in the application of this relation to samples of low carbon residues.

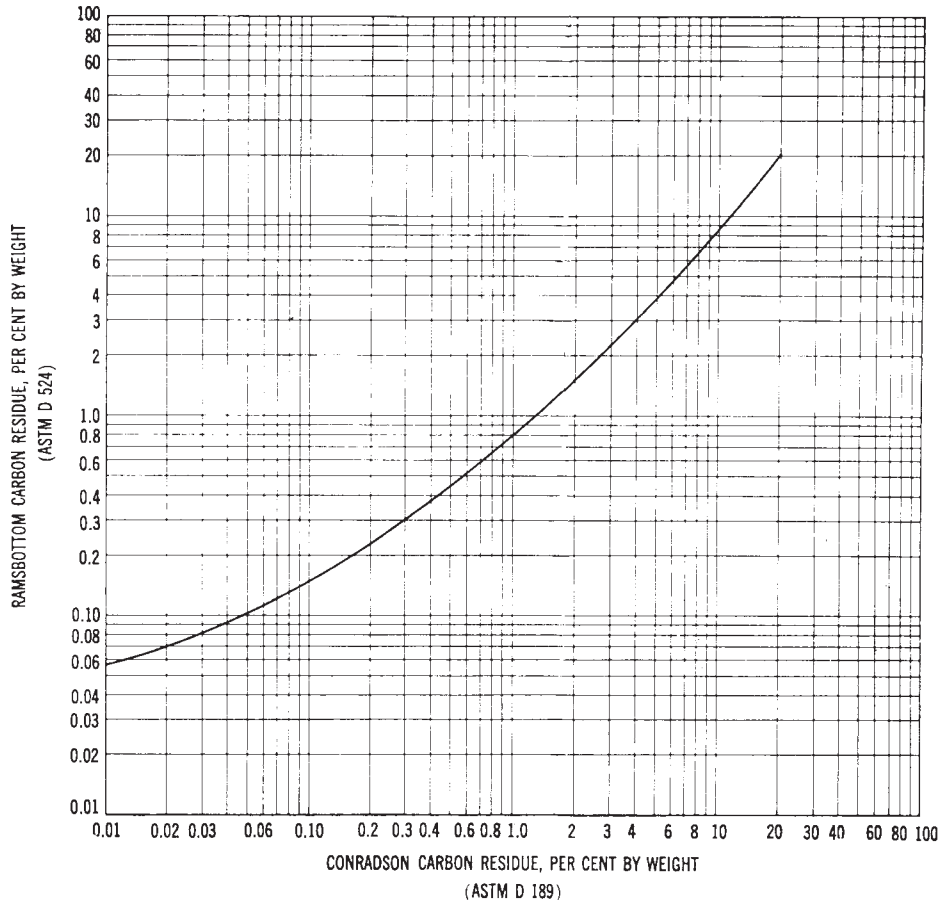

NOTE—All dimensions are in millimetres.

FIG. X2.1 Correlation Data

SUMMARY OF CHANGES

Subcommittee D02.06 has identified the location of selected changes to this standard since the last issue (D 524–00^{e1}) that may impact the use of this standard.

- (1) Rewrote 1.1 to indicate that this test method also applies to 10 % distillation residues.
- (2) Added Note 4 to discuss precision data.
- (3) Added Test Method D 86 to the Referenced Documents.
- (4) Retitled and rewrote Section 10 for clarity and to allow the use of automated distillation equipment.

ASTM International takes no position respecting the validity of any patent rights asserted in connection with any item mentioned in this standard. Users of this standard are expressly advised that determination of the validity of any such patent rights, and the risk of infringement of such rights, are entirely their own responsibility.

This standard is subject to revision at any time by the responsible technical committee and must be reviewed every five years and if not revised, either reapproved or withdrawn. Your comments are invited either for revision of this standard or for additional standards and should be addressed to ASTM International Headquarters. Your comments will receive careful consideration at a meeting of the responsible technical committee, which you may attend. If you feel that your comments have not received a fair hearing you should make your views known to the ASTM Committee on Standards, at the address shown below.

This standard is copyrighted by ASTM International, 100 Barr Harbor Drive, PO Box C700, West Conshohocken, PA 19428-2959, United States. Individual reprints (single or multiple copies) of this standard may be obtained by contacting ASTM at the above address or at 610-832-9585 (phone), 610-832-9555 (fax), or service@astm.org (e-mail); or through the ASTM website (www.astm.org).