



## Standard Practice for Preparation of Paint-Roller Covers for Evaluation<sup>1</sup>

This standard is issued under the fixed designation D 5069; the number immediately following the designation indicates the year of original adoption or, in the case of revision, the year of last revision. A number in parentheses indicates the year of last reapproval. A superscript epsilon (ε) indicates an editorial change since the last revision or reapproval.

---

<sup>ε1</sup> NOTE—Editorial changes were made throughout in December 2002.

---

### 1. Scope

1.1 This practice describes the preparation or breaking-in of paint-roller covers for evaluation.

1.2 This practice is applicable to paint-roller covers having nap lengths up to ½ in. (13 mm).

1.3 *This standard does not purport to address the safety concerns, if any, associated with its use. It is the responsibility of the user of this standard to establish appropriate safety and health practices and determine the applicability of regulatory limitations prior to use.*

### 2. Referenced Documents

#### 2.1 ASTM Standards:

D 3924 Specification for Standard Environment for Conditioning and Testing Paint, Varnish, Lacquer, and Related Materials<sup>2</sup>

### 3. Summary of Practice

3.1 Using the paint chosen for the evaluation, the paint-roller cover to be tested is repeatedly and generously loaded with paint and painted out over the same area of approximately 4 square feet (0.4 m<sup>2</sup>) until it is saturated with paint, that is, the paint-roller cover cannot pick up any more paint, nor apply any more paint to the area being used for break-in.

### 4. Significance and Use

4.1 Until a paint-roller cover is saturated with paint, only part of the paint loaded onto the paint-roller cover can be transferred to a surface being painted. The remainder of the paint is absorbed into the fabric of the paint-roller cover. The amount of paint absorbed by a paint-roller cover is inversely proportional to the amount already present within the paint-roller cover. By saturating the paint-roller cover before testing, quantitative inaccuracies of the amount of paint delivered to a surface are eliminated.

4.1.1 Using a saturated paint-roller cover enables the user to apply paint at controllable spreading rates.

4.1.2 Using a saturated paint-roller cover affords reproducibility, when repeating a test.

### 5. Apparatus

5.1 *Paint Tray.*

5.2 *Paint Roller Frame*, of the same size as the paint-roller cover being prepared.

### 6. Materials

6.1 *Paint*, to be used in test.

6.2 *Primed or Smooth Surface*, to be used for the roller-cover break-in.

### 7. Procedure

7.1 All tests are to be conducted in an atmosphere having a temperature of 73.5 ± 3.5°F (23 ± 2°C) and a relative humidity of 50 ± 5 % (see Specification D 3924).

7.2 Place the paint-roller cover on the frame.

7.3 Load the paint-roller cover with the paint from the tray by rolling the paint-roller cover over the surface of the paint so that just the nap is submersed. See Fig. 1.

7.4 Roll out the roller cover on the surface being used for break-in in an upward and downward motion in no larger an area than 2 square ft (0.2 m<sup>2</sup>) high by the width of the roller cover.

7.5 Reload the paint-roller cover with paint and roll out in the same manner over the same area. Do not increase the area except as necessary to control excess dripping of paint.

7.6 Repeat the above procedure as necessary until the following conditions are met:

7.6.1 Reloading the paint-roller cover does not result in increased paint pickup.

7.6.2 There is so much paint on the surface being used that the fully loaded paint-roller cover cannot transfer any more paint to the surface.

7.6.3 When the above conditions are met, there will be so much paint on the roller cover that constant movement (turning over) is necessary to prevent dripping, and the panel will show profuse sagging of the paint. About six roller-cover loadings are usually necessary to achieve this.

---

<sup>1</sup> This practice is under the jurisdiction of ASTM Committee D01 on Paint and Related Coatings, Materials, and Applications and is the direct responsibility of Subcommittee D01.61 on Paint Application Tools.

Current edition approved Dec. 10, 2002. Published February 2003. Originally approved in 1990. Last previous edition approved in 1990 as D 5069 – 90.

<sup>2</sup> *Annual Book of ASTM Standards*, Vol 06.01.

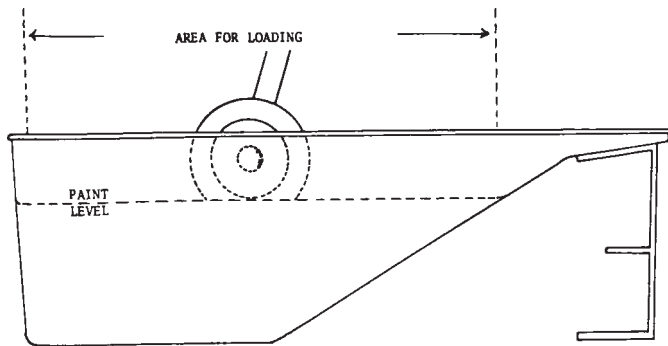

FIG. 1 Loading the Paint Roller

7.7 The roller cover is now prepared for immediate testing.

## 8. Keywords

8.1 break-in; paint roller; paint-roller cover; roller; test preparation

*ASTM International takes no position respecting the validity of any patent rights asserted in connection with any item mentioned in this standard. Users of this standard are expressly advised that determination of the validity of any such patent rights, and the risk of infringement of such rights, are entirely their own responsibility.*

*This standard is subject to revision at any time by the responsible technical committee and must be reviewed every five years and if not revised, either reapproved or withdrawn. Your comments are invited either for revision of this standard or for additional standards and should be addressed to ASTM International Headquarters. Your comments will receive careful consideration at a meeting of the responsible technical committee, which you may attend. If you feel that your comments have not received a fair hearing you should make your views known to the ASTM Committee on Standards, at the address shown below.*

*This standard is copyrighted by ASTM International, 100 Barr Harbor Drive, PO Box C700, West Conshohocken, PA 19428-2959, United States. Individual reprints (single or multiple copies) of this standard may be obtained by contacting ASTM at the above address or at 610-832-9585 (phone), 610-832-9555 (fax), or service@astm.org (e-mail); or through the ASTM website (www.astm.org).*