



# Standard Test Methods for Characterizing Thermoplastic Fabrics Used in Roofing and Waterproofing<sup>1</sup>

This standard is issued under the fixed designation D 4830; the number immediately following the designation indicates the year of original adoption or, in the case of revision, the year of last revision. A number in parentheses indicates the year of last reapproval. A superscript epsilon (ε) indicates an editorial change since the last revision or reapproval.

## 1. Scope

1.1 These test methods cover the procedures for characterizing thermoplastic fabrics (for example polyester, polyamide, polypropylene, etc.) used in prefabricated roofing and waterproofing membranes.

1.2 Procedures appear in the following order:

	Section
Unit Mass	3
Thickness	4
Breaking Load, Elongation and Work-to-Break	5
Trapezoid Tearing Strength	6
Puncture Strength	7
Static Heat Stability	8
Dynamic Heat Stability	9

1.3 *This standard does not purport to address all of the safety concerns, if any, associated with its use. It is the responsibility of the user of this standard to establish appropriate safety and health practices and determine the applicability of regulatory limitations prior to use.*

## 2. Referenced Documents

### 2.1 ASTM Standards:

- D 76 Specification for Tensile Testing Machines for Textiles<sup>2</sup>
- D 123 Terminology Relating to Textiles<sup>2</sup>
- D 885 Test Methods for Tire Cords, Tire Cord Fabrics, and Industrial Filament Yarns Made from Man-Made Organic-Base Fibers<sup>2</sup>
- D 1117 Test Methods for Nonwoven Fabrics<sup>2</sup>
- D 1776 Practice for Conditioning Textiles for Testing<sup>2</sup>
- D 4354 Practice for Sampling of Geosynthetics for Testing<sup>3</sup>
- D 5035 Test Method for Breaking Strength and Elongation of Textile Fabrics (Strip Method)<sup>4</sup>
- D 5729 Test Method for Thickness of Nonwoven Fabrics<sup>4</sup>
- D 5733 Test Method for Tearing Strength of Nonwoven Fabrics by the Trapezoid Procedure<sup>4</sup>

<sup>1</sup> These test methods are under the jurisdiction of ASTM Committee D-8 on Roofing, Waterproofing, and Bituminous Materials and are the direct responsibility of Subcommittee D08.04 on Fabrics for Bituminous Roofing and Waterproofing.

Current edition approved Jan. 10, 1998. Published September 1998. Originally published as D 4830 – 88. Last previous edition D 4830 – 95.

<sup>2</sup> Annual Book of ASTM Standards, Vol 07.01.

<sup>3</sup> Annual Book of ASTM Standards, Vol 04.09.

<sup>4</sup> Annual Book of ASTM Standards, Vol 07.02.

E 1 Specification for ASTM Thermometers<sup>5</sup>

E 18 Test Methods for Rockwell Hardness and Rockwell Superficial Hardness of Metallic Materials<sup>6</sup>

## 3. Unit Mass

3.1 Determine the unit mass of the fabric using procedures described in Test Methods D 1117. Report in g/m<sup>2</sup> or oz/yd<sup>2</sup>.

## 4. Thickness

4.1 Determine fabric thickness following procedures described in Test Method D 5729.

## 5. Breaking Load, Elongation, and Work-to-Break

5.1 Determine the breaking load and elongation by the cut strip method described in Test Method D 5035 with the following exceptions:

5.1.1 *Test Specimens*—Cut each specimen 51 ± 1 mm (2.0 ± 0.05 in.) wide and 203 ± 1 mm (8.0 ± 0.05 in.) long. The gage length shall be 152 ± 1 mm (6.0 ± 0.05 in.).

5.1.2 *Apparatus*—The apparatus shall be a CRE (Constant Rate of Extension) machine described in Specification D 76. The machine will be set for an extension rate of 5 mm/s or 12 in./min.

5.2 *Calculation*—Report textile conditions and the average breaking load in N/m or lbf/in. and the elongation at break in percent.

5.3 *Work-to-Break*—The procedure and calculation shall be as described in Test Methods D 885 with the exception that the load-elongation curve will be from specimens used in determining breaking load and elongation as described in 5.1 and 5.2.

## 6. Trapezoid Tearing Strength

6.1 Determine trapezoid tearing strength of the fabric following procedures described in Test Method D 5733.

## 7. Puncture Strength

### 7.1 Scope:

7.1.1 This test method is used to measure the puncture strength of thermoplastic fabrics used in roofing.

7.1.2 This procedure is applicable to conditioned fabrics.

<sup>5</sup> Annual Book of ASTM Standards, Vol 14.03.

<sup>6</sup> Annual Book of ASTM Standards, Vol 03.01.

7.2 Summary of Method:

7.2.1 A specimen of the fabric is clamped without tension between grooved, circular plates of a ring clamp attachment secured in a tensile testing machine. A force is exerted against the center of the specimen by a solid steel rod attached to the load indicator until rupture occurs.

7.3 Significance and Use:

7.3.1 Puncture failures are recognized in the roofing industry. Puncture strength is felt to reflect the fabric's ability to withstand aggregate or ballast stone penetration. This test method is used to obtain the relative puncture resistance of various fabrics.

7.4 Apparatus:

7.4.1 *Tensile Testing Machine*, of the constant-rate-of-extension type (CRE), with autographic recorder conforming to the requirements of Specification D 76.

7.4.2 *Ring Clamp Attachment*, consisting of concentric grooved plates with an internal diameter of  $44.45 \pm 0.025$  mm ( $1.750 \pm 0.001$  in.), capable of clamping fabrics without slippage.

7.4.3 *Solid Steel Rod*, with a hardness in the range of Rockwell C (HRC) 50 to 60, with a diameter of  $7.938 \pm 0.013$  mm ( $0.3125 \pm 0.0005$  in.) and a hemispherical end with a radius of  $3.970 \pm 0.013$  mm ( $0.1563 \pm 0.0005$  in.) for contacting the fabric surface (see Fig. 1). The surface of the hemispherical end should be smooth and polished to a surface smoothness of  $RMS \leq 8$ . (RMS is the root-mean-square method of describing surface smoothness.)<sup>7</sup>

7.5 Sampling, Number of Specimens, and Selection of Samples:

7.5.1 *Lot Sample*—As a lot sample for acceptance testing, take at random the number of rolls of fabric directed in an applicable material specification or other agreement between the purchaser and the supplier, such as agreement to sample as directed in Practice D 4354. Consider rolls of fabric to be the primary sampling units.

7.5.2 *Laboratory Sample*—Take, for the laboratory sample, a sample extending the width of the fabric and approximately 1.0 m (39 in.) along with the selvage from each roll in the lot sample. The sample may be taken from the end portion of a roll provided there is no evidence that it is distorted or different from other portions of the roll. In cases of dispute, take a sample that will exclude fabric from the outer wrap of the roll or the inner wrap around the core.

7.5.3 Unless otherwise agreed upon or specified in applicable material specifications, test a number of specimens from each laboratory sample that will give a precision of  $\pm 5\%$  at a probability level of 90 %, not to exceed ten specimens per sample.

7.6 Preparation of Test Specimen:

7.6.1 Each specimen shall be cut 76 by 76 mm (3.0 by 3.0 in.) to ensure proper clamping. Specimens should be taken on the diagonal across the sample so that no two specimens will contain the same machine direction and cross machine direction yarns or fibers. Unless otherwise specified, no specimen should be taken within 51 mm (2.0 in.) of the selvage or edge.

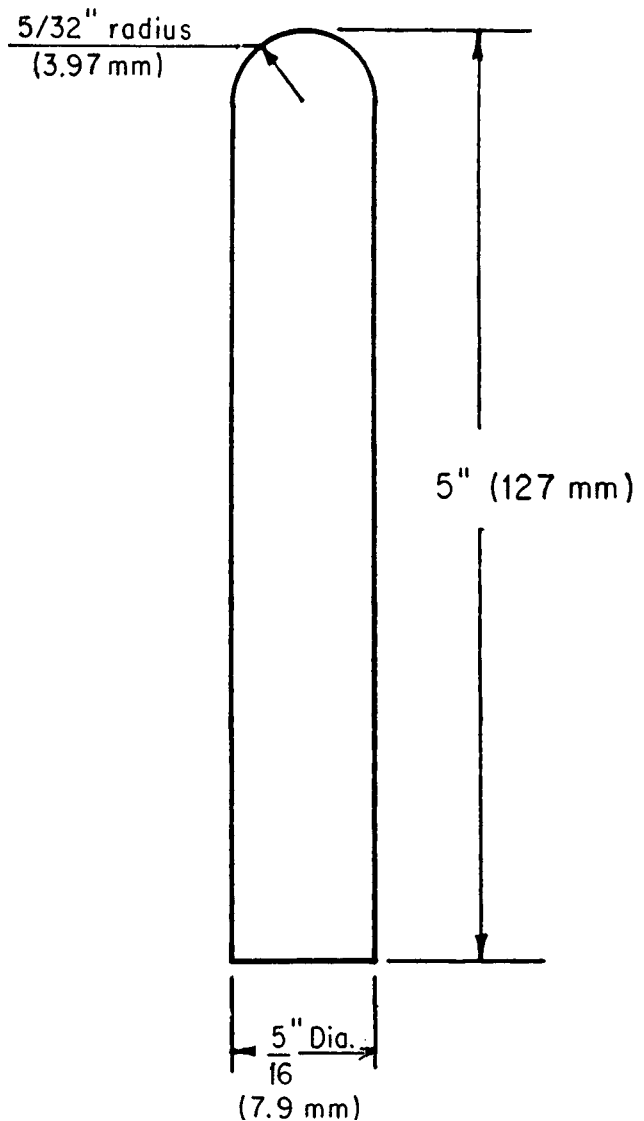

FIG. 1 Steel Rod

7.7 Conditioning:

7.7.1 Condition the specimens as directed in Practice D 1776.

7.8 Procedure:

7.8.1 All testing must be conducted at standard textile laboratory conditions as required in Practice D 1776.

7.8.2 Select the load range of the tensile testing machine such that the rupture occurs between 15 and 85 % of the full-scale load.

7.8.3 Center and secure the specimen between the grooved plates, ensuring that the fabric extends beyond the outer edges of the plates.

7.8.4 *Measurement of Rupturing Load*—Test at a machine speed of 5 mm/s or 12 in./min until the puncture rod completely ruptures the specimen. Read the puncture strength as the greatest force in N (lbf) registered on the recording instrument during the test.

7.8.5 If the yarns or fibers fail to break due to the slippage of the specimen in the ring clamp or if the rod slips between the yarns or fibers without causing yarn or fiber breakage, discard

<sup>7</sup> See *Machinery's Handbook*, 19th ed., Industrial Press, H. L. Horton, ed.

the result and test another specimen.

#### 7.9 Calculation:

7.9.1 Calculate the average of the rupturing load for all acceptable test results as read directly from the recording instrument.

#### 7.10 Report:

7.10.1 Report all of the following:

7.10.1.1 Product(s) or material(s) sampled.

7.10.1.2 Test method used, identifying both the type of specimen and type of testing machine.

7.10.1.3 Sample conditioning.

7.10.1.4 Average puncture strength in N (lbf) of the specimens tested and number of specimens.

7.10.1.5 Variation, if any, from the described test method.

#### 7.11 Precision and Bias:

7.11.1 *Precision*—The precision of the procedure in this test for measuring puncture strength is being determined.

7.11.2 *Bias*—Since there is no accepted reference material suitable for determining the bias for the procedure in this test for puncture strength, no statement on bias is being made.

## 8. Static Heat Stability

### 8.1 Scope:

8.1.1 This test method covers the determination of the heat stability of thermoplastic fabrics at typical asphalt application temperatures during manufacture of prefabricated membrane.

### 8.2 Summary of Method:

8.2.1 Fabric specimens are placed in an oven for a fixed amount of time at a specific temperature. The change in length of each specimen is recorded and expressed as a percentage of the original length.

8.2.2 This process is performed at four temperatures, and a plot can be made comparing the percent change in length versus temperature.

### 8.3 Significance and Use:

8.3.1 This test method is used to determine the comparative heat stability of thermoplastic fabrics, as received, at typical asphalt application temperatures.

### 8.4 Apparatus:

8.4.1 *Self-Supporting Aluminum Mounting Board*—Details on the construction and dimensions are described in Annex A1.

8.4.2 *Oven*, mechanical-convection type, for controlled circulation of air. The oven must be capable of containing the mounting board, and shall be equipped with a temperature-control system designed to maintain oven temperatures at the levels specified in 8.7.1 with a precision of  $\pm 1^\circ\text{C}$  ( $\pm 2^\circ\text{F}$ ). The oven should also be equipped with a visible thermometer which measures the inside oven temperature.

8.4.3 *Ruler*, graduated at 1.0 mm or  $\frac{1}{32}$  in. and at least 25 mm (1.0 in.) wide.

8.4.4 *Clips*, noninsulated alligator clips weighing no more than 1.4 g (0.05 oz) each.

8.4.5 *Timing Device*, reading in minutes with an audible alarm.

8.4.6 *Marking Pen*, indelible ink or felt-tip marker, capable of marking specimens.

### 8.5 Preparation of Specimens:

8.5.1 Take the specimens for the measurement of the static heat stability for the machine direction from different positions

across the fabric and for the cross machine direction from different positions along the length of the fabric.

8.5.2 Test specimens should be cut no closer than 51 mm (2.0 in.) from the selvage and no closer than 1 m (39 in.) from the end of the roll.

8.5.3 Each specimen should be  $267 \pm 3$  mm ( $10.5 \pm \frac{1}{8}$  in.) long and  $25 \pm 3$  mm ( $1 \pm \frac{1}{8}$  in.) wide.

8.5.4 Cut twelve specimens from the sample with their long dimension parallel to the machine direction. Label each specimen as a machine direction specimen.

8.5.5 Cut twelve specimens from the sample with their long dimension parallel to the cross machine direction. Label each specimen as a cross machine direction specimen.

### 8.5.6 Marking the Specimens:

8.5.6.1 Lay out a specimen fully extended on a flat, horizontal surface. Draw a line on the specimen 6 mm ( $\frac{1}{4}$  in.) from the end, parallel to the short dimension (width). Draw a similar line on the other end of the specimen.

8.5.6.2 Prepare the other specimens as in 8.5.6.1.

### 8.6 Conditioning:

8.6.1 Condition the specimens as directed in Practice D 1776.

### 8.7 Procedure:

8.7.1 Perform 8.7.1.1-8.7.1.9 at the following suggested temperatures: 177, 191, 204, and  $218 \pm 1^\circ\text{C}$  (350, 375, 400, and  $425 \pm 2^\circ\text{F}$ ).

8.7.1.1 Set the oven to the desired test temperature and allow to stabilize a minimum of  $\frac{1}{2}$  h.

8.7.1.2 Select three machine direction specimens and three cross machine direction specimens. Measure and record the distance between the two scribed lines to the nearest 1.0 mm or  $\frac{1}{32}$  in., numbering the specimens as necessary.

8.7.1.3 Place the mounting board in a horizontal position and secure the tops of the six specimens in the clamps up to the top 6-mm ( $\frac{1}{4}$ -in.) line.

8.7.1.4 Attach an alligator clip at the center of the lower edge of each specimen. Do not place the clip higher than the lower 6-mm ( $\frac{1}{4}$ -in.) line.

8.7.1.5 When the oven temperature has stabilized, put the mounting board in its vertical position (as shown in Fig. A1.1) in the oven.

8.7.1.6 Check the oven temperature. Once the oven temperature has returned to the desired test temperature, set the timing device for 5 min. Do not allow the oven temperature to exceed the test temperature.

8.7.1.7 When timing is completed, remove the assembly from the oven and place it vertically at room temperature. Leave the specimens on the mounting board for 15 min with alligator clips still attached.

8.7.1.8 Remove the alligator clips and release the specimens from the board. Lay the specimens on a flat surface and allow them to condition an additional 15 min before any measurements are made.

8.7.1.9 To measure the specimen length, cover the specimen with the ruler. Measure the length of the specimen between the two lines while the specimen is being pressed flat by the ruler. Record this length for each specimen to the nearest 1.0 mm or  $\frac{1}{32}$  in.

## 8.8 Calculations:

8.8.1 Calculate the average length between the scribed lines for the machine direction specimens and for the cross machine direction specimens at each test temperature, before and after exposure to the oven.

8.8.2 Calculate the percentage change in length for the machine direction and cross machine direction specimens at each test temperature as follows:

$$\text{Percent Change in Length} = [(A - B)/B] \times 100 \quad (1)$$

where:

*A* = average length between lines after exposure, and

*B* = average length between lines before exposure.

8.8.2.1 A positive sign for the percent change in length indicates an increase in specimen length upon heating. A negative sign indicates a decrease in specimen length upon heating.

## 8.9 Report:

8.9.1 State that the tests were carried out as directed in this test method and report the static heat stability as the percent change in length for both the machine and cross machine directions at each specific temperature. Describe the product(s) or material(s) sampled, the number of specimens and the method of sampling used.

8.9.2 The data may be expressed in the form of a graph indicating the percent change in length versus temperature for both the machine and cross machine directions.

## 8.10 Precision and Bias:

8.10.1 *Precision*—The precision of the procedure in this test for measuring static heat stability is being determined.

8.10.2 *Bias*—Since there is no accepted reference material suitable for determining the bias for the procedure in this test for static heat stability, no statement on bias is being made.

## 9. Dynamic Heat Stability

### 9.1 Scope:

9.1.1 This test method covers the determination of the dynamic heat stability of thermoplastic fabrics at typical asphalt application temperatures and operating stresses during manufacture of prefabricated membrane.

### 9.2 Summary of Method:

9.2.1 Weights are attached to fabric specimens which are then heated in an oven for a fixed amount of time. The change in length of each specimen is recorded and expressed as a percentage of the original length.

9.2.2 Data are obtained using several different weights and a plot is made comparing the percent change in length versus weight applied.

### 9.3 Significance and Use:

9.3.1 This test method is used to develop a relationship between the change in length of a fabric specimen and the load applied, at a specific temperature. The loads and temperatures used in this test are typical of those seen in the roofing manufacturing process.

### 9.4 Apparatus:

9.4.1 *Self-Supporting Aluminum Mounting Board*—See Annex A1.

9.4.2 *Oven*—See 8.4.1.

9.4.3 *Four “Bulldog” Clamps*, 51 mm (2.0 in.) wide and

weighing approximately 10 g (0.353 oz), with silicon seal affixed and cured to the inside of the clamps to improve grip on test specimens. The exact weight of each clamp should be determined and recorded.

9.4.4 *Ruler*—See 8.4.3.

9.4.5 *Hook Weight Set*, to enable testing in the range from 50 to 1000 g.

9.4.6 *Timing Device*—See 8.4.5.

9.4.7 *Marking Pen*—See 8.4.6.

### 9.5 Preparation of Specimens:

9.5.1 Prepare specimens in accordance with 8.5.1 and 8.5.2.

9.5.2 Each specimen should be  $229 \pm 3$  mm ( $9.0 \pm \frac{1}{8}$  in.) long and  $25 \pm 3$  mm ( $1.0 \pm \frac{1}{8}$  in.) wide.

9.5.3 Cut 12 specimens from the sample with their long dimension parallel to the machine direction. Label each specimen as a machine direction specimen.

9.5.4 Cut 12 specimens from the sample with their long dimension parallel to the cross machine direction. Label each specimen as a cross machine direction specimen.

### 9.5.5 Marking and Reinforcing the Specimens:

9.5.5.1 Lay out a specimen fully extended on a flat, horizontal surface. Draw a line on the specimen 25 mm (1.0 in.) from the end, parallel to the short dimension (width). Draw a similar line on the other end of the specimen.

9.5.5.2 Fold over one end of the specimen, bringing it up to the nearest scribed line. Fasten the end of the specimen using two staples, placed side by side along the line. Do not cover the line. Repeat for the other end of the specimen.

9.5.5.3 Prepare the other specimens as in 9.5.5.1 and 9.5.5.2.

### 9.6 Conditioning:

9.6.1 Condition the specimens as directed in Practice D 1776.

### 9.7 Procedure:

9.7.1 Repeat 9.7.3-9.7.11 at a specific temperature until three values are obtained at each of the following loads, for each direction: 50, 100, 200, and 500 g. The following temperatures are recommended: 177, 191, 204, or  $218 \pm 1^\circ\text{C}$  (350, 375, 400, or  $425 \pm 2^\circ\text{F}$ ).

NOTE 1—The weight of the clamp should be added to the above weights when reporting the results and plotting the data.

9.7.2 Additional tests may be performed using 1000 g, or any desired combination of weights. Test specimens may be shortened to 152 mm (6.0 in.) between scribed lines to accommodate longer weights.

9.7.3 Set the oven to the desired test temperature and allow to stabilize a minimum of  $\frac{1}{2}$  h.

9.7.4 Select four test specimens, numbering each and identifying its major direction. Measure and record the distance between the two scribed lines to the nearest 1.0 mm or  $\frac{1}{32}$  in.

9.7.5 Place the mounting board in a horizontal position and secure the tops of the four specimens in the clamp up to the top scribed line.

9.7.6 Attach a “Bulldog” clamp to each specimen, using the lower line as a guide.

9.7.7 Put the mounting board in the upright position (as shown in Fig. A1.1) and attach the 50-g, 100-g, 200-g, and 500-g weights, respectively, to the four “Bulldog” clamps.

9.7.8 When the oven temperature has stabilized, put the mounting board in the oven in the upright position.

9.7.9 Check the oven temperature. Once the oven temperature has returned to the desired test temperature, set the timing device for 5 min. Do not allow the oven temperature to exceed the test temperature.

9.7.10 When timing is completed, remove the assembly from the oven and place it upright at room temperature. Leave the specimens on the mounting board for 15 min. with weights still attached.

9.7.11 Record the value of the weight used for each specimen, including the clamp. Remove the weights and clamps and release the specimens from the board. Lay the specimens on a flat surface and allow them to condition an additional 15 min before any measurements are made.

9.7.12 To measure the specimen length, cover the specimen with the ruler. Measure the length between the two lines while the specimen is being pressed flat by the ruler. Record this length of each specimen to the nearest 1.0 mm or 1/32 in.

9.8 Calculations:

9.8.1 Calculate the percent change in length for each specimen as follows:

$$\text{Percent Change in Length} = [(A - B)/B] \times 100 \quad (2)$$

where:

A = length between lines after exposure, and

B = length between lines before exposure.

9.8.2 A positive sign for the percent change in length indicates an increase in specimen length upon heating. A negative sign indicates a decrease in specimen length upon heating.

9.8.3 Calculate the average percent change in length for each direction at each weight level used. Plot the percent change in length versus weight used for each direction.

9.9 Report:

9.9.1 State that the tests were carried out as directed in this test method and report the dynamic heat stability as the percent change in length versus weight used for each direction at each temperature. Describe the product(s) or material(s) sampled, the number of specimens, and the method of sampling used.

9.10 Precision and Bias:

9.10.1 Precision—The precision of the procedure in this test for measuring dynamic heat stability is being determined.

9.10.2 Bias—Since there is no accepted reference material suitable for determining the bias for the procedure in this test for dynamic heat stability, no statement on bias is being made.

10. Keywords

10.1 heat stability; prefabricated roofing and waterproofing membrane; thermoplastic fabric; trapezoid tearing strength

ANNEX

(Mandatory Information)

A1. INSTRUCTIONS FOR THE BUILDING OF THE MOUNTING BOARD (SEE FIGS. A1.1 AND A1.2)

A1.1 Obtain a piece of aluminum sheet of suitable dimension such that when bent it will have a 381 by 381 by 3.2-mm (15 by 15 by 1/8-in.) face and a base which is 381 mm wide and extends 152 mm (6.0 in.) back. The face should be at an angle of 10° from the vertical.

A1.2 Draw a line across the top of the board no more than 76 mm (3.0 in.) from the top edge.

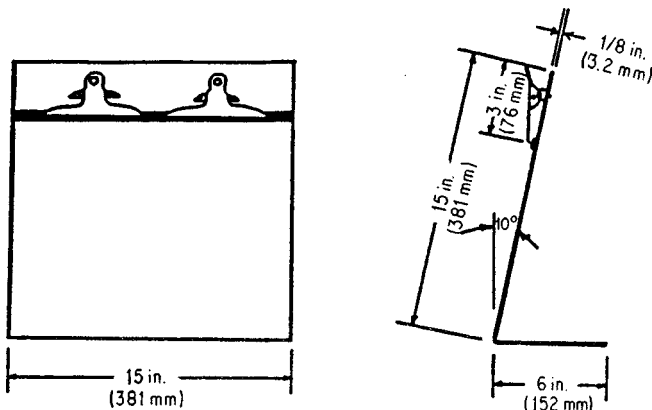

FIG. A1.1 Self-Supporting Aluminum Mounting Board

A1.3 Remove the clamps from two standard clipboards. The clamps should be at least 152 (6.0 in.) wide. Place the board in a horizontal position. Place the clamps side by side on the board with the lower edges of the clamps positioned along the line which was drawn. Drill the necessary holes into the board and affix the clamps using screws or rivets.

A1.4 Secure the clamps in an open position. Build up an even 3-mm (1/8-in.) layer of silicone seal which extends 6 mm (1/4 in.) on either side of the scribed line. This may be accomplished by building up layers of masking tape (or any other suitable material) 6 mm (1/4 in.) from both sides of the line to act as a template for the seal. This technique is illustrated in Fig. A1.2. Keep the clamps secured in an open

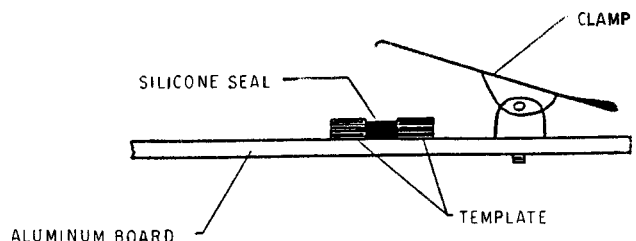

FIG. A1.2 Schematic Diagram of Template

position for one day to allow the seal to cure. Carefully remove the template once the seal has cured.

*The American Society for Testing and Materials takes no position respecting the validity of any patent rights asserted in connection with any item mentioned in this standard. Users of this standard are expressly advised that determination of the validity of any such patent rights, and the risk of infringement of such rights, are entirely their own responsibility.*

*This standard is subject to revision at any time by the responsible technical committee and must be reviewed every five years and if not revised, either reapproved or withdrawn. Your comments are invited either for revision of this standard or for additional standards and should be addressed to ASTM Headquarters. Your comments will receive careful consideration at a meeting of the responsible technical committee, which you may attend. If you feel that your comments have not received a fair hearing you should make your views known to the ASTM Committee on Standards, 100 Barr Harbor Drive, West Conshohocken, PA 19428.*