



# Standard Test Methods for Hydrogen Content of Light Distillates, Middle Distillates, Gas Oils, and Residua by Low-Resolution Nuclear Magnetic Resonance Spectroscopy<sup>1</sup>

This standard is issued under the fixed designation D 4808; the number immediately following the designation indicates the year of original adoption or, in the case of revision, the year of last revision. A number in parentheses indicates the year of last reapproval. A superscript epsilon ( $\epsilon$ ) indicates an editorial change since the last revision or reapproval.

*This standard has been approved for use by agencies of the Department of Defense.*

## 1. Scope \*

1.1 These test methods cover the determination of the hydrogen content of petroleum products ranging from atmospheric distillates to vacuum residua using a continuous wave, low-resolution nuclear magnetic resonance spectrometer. (Test Method D 3701 is the preferred method for determining the hydrogen content of aviation turbine fuels using nuclear magnetic resonance spectroscopy.)

1.2 Three test methods are included here that account for the special characteristics of different petroleum products and apply to the following distillation ranges:

| Test Method | Petroleum Products              | Boiling Range, °C (°F)<br>(approximate) |
|-------------|---------------------------------|---|
| A           | Light Distillates               | 15–260 (60–500)                         |
| B           | Middle Distillates,<br>Gas Oils | 200–370 (400–700)                       |
| C           | Residua                         | 370–510 (700–950)<br>510+ (950+)        |

1.3 The preferred units are mass %.

1.4 *This standard does not purport to address all of the safety concerns, if any, associated with its use. It is the responsibility of the user of this standard to establish appropriate safety and health practices and determine the applicability of regulatory limitations prior to use.* For specific hazard statements, see Section 6.1.

## 2. Referenced Documents

### 2.1 ASTM Standards:

- D 3701 Test Method for Hydrogen Content of Aviation Turbine Fuels by Low Resolution Nuclear Magnetic Resonance Spectrometry<sup>2</sup>
- D 4057 Practice for Manual Sampling of Petroleum and Petroleum Products<sup>2</sup>
- D 5291 Test Methods for Instrumental Determination of

Carbon, Hydrogen, and Nitrogen in Petroleum Products and Lubricants<sup>3</sup>

## 3. Summary of Test Methods

3.1 A test specimen is compared in a continuous wave, low-resolution nuclear magnetic resonance (NMR) spectrometer with a reference standard sample. The spectrometer records in a nondestructive fashion the absolute concentration of hydrogen atoms in the reference standard and test sample. The absolute hydrogen concentrations reported by the integrator on the NMR instrument for the standard and test specimens are used as a means of comparing the theoretical hydrogen content of the standard with that of the sample, the result being expressed as the hydrogen content (on a mass % basis) of the sample.

3.2 To ensure an accurate measure of the absolute hydrogen content of the reference standard and sample, it is necessary to ensure that the measured hydrogen integrator counts are always directly proportional to the absolute hydrogen content of the standard and sample.

3.3 Undercounting of the reference standard with respect to the sample is avoided in Test Methods B and C by dilution of the standard with a relaxation reagent solution. Undercounting of highly viscous or solid test samples is avoided by dissolving the sample in a non-hydrogen containing solvent, which ensures that all of the weighed sample is in a fluid and homogeneous solution at the time of measurement. An elevated sample temperature at the time of measurement also ensures a homogeneous liquid-phase sample.

## 4. Significance and Use

4.1 The hydrogen content represents a fundamental quality of a petroleum product that has been correlated with many of the performance characteristics of that product.

4.2 This test method provides a simple and more precise alternative to existing test methods, specifically combustion techniques (Test Method D 5291) for determining the hydrogen content on a range of petroleum products.

<sup>1</sup> This test method is under the jurisdiction of ASTM Committee D02 on Petroleum Products and Lubricants and is the direct responsibility of Subcommittee D02.03 on Elemental Analysis.

Current edition approved Nov. 10, 2001. Published December 2001. Originally published as D 4808 – 88. Last previous edition D 4808 – 98.

<sup>2</sup> *Annual Book of ASTM Standards*, Vol 05.02.

<sup>3</sup> *Annual Book of ASTM Standards*, Vol 05.03.

**\*A Summary of Changes section appears at the end of this standard.**

## 5. Apparatus

NOTE 1—This test method has been written around the Newport Analyzer Mark IIIIF or its replacement version, the Newport 4000 (Oxford Analytical Instruments, Ltd., Oxford, England), and the details of the test method are to be read in conjunction with the manufacturer's handbook. These instruments have demonstrated statistically indistinguishable performance in these standard methods and in Test Method D 3701. Any similar instrument is acceptable, provided that the new instrument is adequately correlated and proved to be statistically similar. As of the mid-1990's however, the Newport 4000 instrument is no longer being manufactured by the vendor. No newer models are currently being manufactured as replacements for the Newport 4000 instrument.

### 5.1 Nuclear Magnetic Resonance Spectrometer:

5.1.1 A low-resolution, continuous wave instrument capable of measuring a nuclear magnetic resonance signal due to hydrogen atoms in the sample and includes an excitation and detection coil of suitable dimensions to contain the test cell; an electronic unit, to control and monitor the magnet and coil, and containing: circuits, to control and adjust the radio-frequency level and audio-frequency gain; and integrating counter, with variable time period in seconds.

5.1.2 Test Methods B and C also require that the instrument has the ability to equilibrate samples within the probe at an elevated temperature (50°C).

5.2 *Conditioning Block*—A block of aluminum alloy drilled with holes of sufficient size to accommodate the test cells with the mean height of the sample being at least 20 mm below the top of the conditioning block, capable of holding the sample at the given test temperature (see Fig. 1).

5.3 *Test Cells*—Nessler-type tubes of approximately 100-mL capacity with a nominal external diameter of 34 mm and a nominal internal diameter of 31 mm marked at a distance of 51 mm above the bottom of the tube by a ring around the circumference. The variation between the internal diameters of the test cells used for the sample and reference material should not be greater than  $\pm 0.5$  mm.

NOTE 2—To avoid potential difficulties with tightness when the test cell is introduced into the magnet coil, users are cautioned to avoid test cells that have nominal external diameters that are greater than 34.2 mm.

5.4 *Polytetrafluoroethylene (PTFE) Plugs*, for closing the test cells and made from pure PTFE.

5.5 *Insertion Rod*—A metal rod with a threaded end used for inserting and removing the PTFE plugs from the test cells (see Fig. 1).

5.6 *Analytical Balance*—A top pan-type balance, capable of weighing the test cells in an upright position to an accuracy of at least 0.001 g.

5.7 *Beakers*, 150 mL and 50 mL with pour spouts.

5.8 *Glass Stirring Rod*, approximately 250-mm length.

## 6. Reagents and Materials

6.1 *Purity of Reagents*—Reagent grade chemicals shall be used in all tests. Unless otherwise indicated, it is intended that all reagents shall conform to the specifications of the Committee on Analytical Reagents of the American Chemical Society,

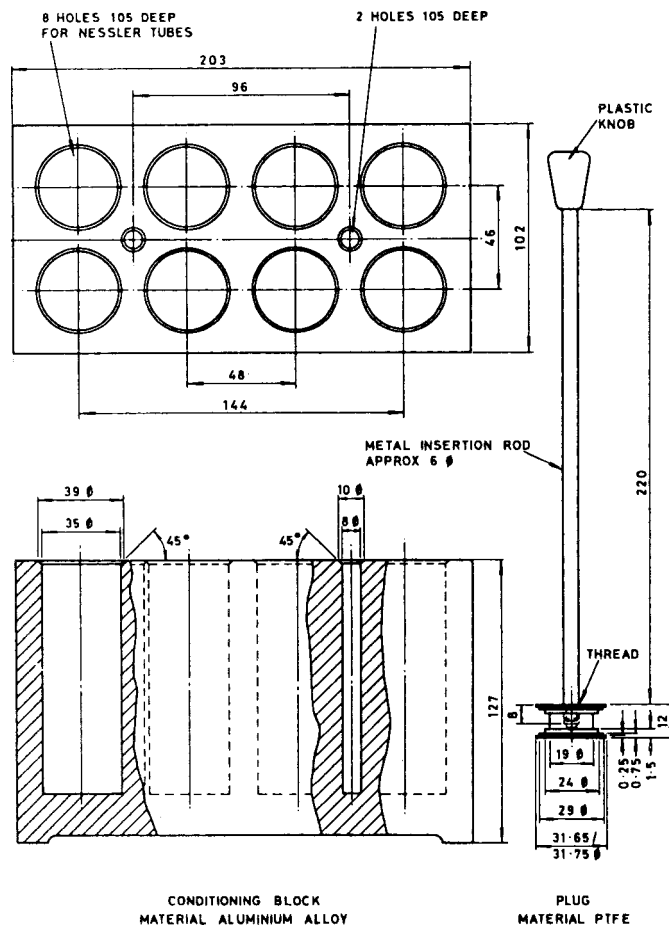

FIG. 1 Conditioning Block and Insertion Rod

where such specifications are available.<sup>4</sup> Other grades may be used, provided it is first ascertained that the reagent is of sufficiently high purity to permit its use without lessening the accuracy of the determination.

6.2 *Reference Standard—n-Dodecane*. (**Warning—Flammable.**)

6.3 *Relaxation Reagent Solution*, prepared from ferric acetylacetonate ( $\text{Fe}(\text{C}_5\text{H}_7\text{O}_2)_3$ —MW = 353.16, reagent grade)—Prepare a fresh 0.02 M  $\text{Fe}(\text{C}_5\text{H}_7\text{O}_2)_3$  solution by dissolving 1.77 g of  $\text{Fe}(\text{C}_5\text{H}_7\text{O}_2)_3$  in 250 mL TCE. If any of the  $\text{Fe}(\text{C}_5\text{H}_7\text{O}_2)$  remains undissolved, filter the solution, and use the filtrate in subsequent steps.

6.4 *Tetrachloroethylene (TCE)*. (**Warning—Cancer-suspect agent.**)

## 7. Sampling

7.1 Take a homogeneous sample in accordance with Practice D 4057. Mix the sample prior to taking a representative aliquot as the test specimen. Middle distillates, gas oils, and

<sup>4</sup> *Reagent Chemicals, American Chemical Society Specifications*, American Chemical Society, Washington, DC. For suggestions on the testing of reagents not listed by the American Chemical Society, see *Analar Standards for Laboratory Chemicals*, BDH Ltd., Poole, Dorset, U.K., and the *United States Pharmacopeia and National Formulary*, U.S. Pharmacopeial Convention, Inc. (USPC), Rockville, MD.

residue can require heating to facilitate mixing to obtain a homogeneous test specimen, as described in 8.2.2.2 and 8.3.2.

## 8. Preparation of Test Specimen and Standard

### 8.1 Test Method A—Light Distillates

8.1.1 Take a clean and dry test cell and PTFE plug, and weigh them together to the nearest 0.001 g and record the weight. Add  $30 \pm 1$  mL of the reference standard or test specimen to the tube, taking extreme care to prevent splashing the liquid above the line inscribed on the tube. Use a pipet for this operation.

8.1.2 Using the insertion rod, push the PTFE plug into the tube until it is about 3 cm above the liquid surface, being careful to keep the tube upright. A gentle twisting or rocking of the plug as it is inserted usually aids the escape of air from the test cell and ensures that the lip of the PTFE plug is turned up around the entire circumference. Take care to ensure that this is so, since a plug that is not properly inserted allows sample evaporation and gives rise to erroneous results.

NOTE 3—If difficulties are encountered in the insertion of the PTFE plug, this operation is facilitated by inserting a length of thin (less than 0.2-mm diameter) and clean copper wire down the inside surface of the test cell until it is approximately 4 cm from the graduation mark, and then pushing the PTFE plug down past the wire which is then removed.

8.1.3 Unscrew the insertion rod carefully and remove without disturbing the plug and without contacting the liquid with the under surface of the plug.

8.1.4 Weigh the test cell containing the test specimen or standard and plug. Record this mass as  $M_S$  or  $M_R$ , respectively, to the nearest 0.001 g.

8.1.5 Place the test cell in the sample conditioning block to equilibrate.

8.1.6 Use procedures 8.1.1 through 8.1.5 to prepare both the reference and sample test cells.

### 8.2 Test Method B—Middle Distillates, Gas Oils

#### 8.2.1 Reference Standard Preparation:

8.2.1.1 Take a clean and dry test cell with PTFE plug and a 150-mL beaker with glass rod. Weigh the test cell with plug and beaker with glass rod to the nearest 0.001 g and record as tare masses.

8.2.1.2 Add 20 g of the reference standard, *n*-dodecane, to the beaker. Record this mass to the nearest 0.001 g as  $S_M$ .

8.2.1.3 To the beaker add 8.6 g TCE and 4.7 g of relaxation reagent solution, as described in 6.3, consisting of TCE and  $\text{Fe}(\text{C}_5\text{H}_7\text{O}_2)_3$  (40 % dilution of reference standard with 1 mg relaxation reagent/mL). Mix thoroughly using the glass stirring rod.

NOTE 4—Burets can also be used to aid the addition of TCE and relaxation reagent solutions.

8.2.1.4 Transfer this solution from the beaker to the test cell, using the glass rod to prevent splashing the liquid above the line inscribed on the test cell. Fill the test cell to the prescribed level, just below this mark.

8.2.1.5 Continue as in 8.1.2 and 8.1.3.

8.2.1.6 Weigh the test cell containing the reference solution and plug. Record the mass of the reference solution to the nearest 0.001 g as  $M_1$ .

8.2.1.7 Weigh the beaker and glass rod containing the

unused solution, and record the mass of the remaining solution to the nearest 0.001 g as  $M_2$ .

8.2.1.8 Place the test cell containing reference solution into the conditioning block to equilibrate.

#### 8.2.2 Test Specimen Preparation:

8.2.2.1 Take a clean and dry test cell with PTFE plug and a 150-mL beaker with glass stirring rod. Weigh the test cell with plug and the beaker with glass rod to the nearest mg, and record as tare masses.

8.2.2.2 Add 20 g of the test specimen to the beaker. Record this mass to the nearest 0.001 g as  $S_M$ . All samples shall be homogeneous prior to sampling. If the sample is viscous or contains waxy materials, heat the sample in its container to approximately 60°C and mix with a high-speed shear mixer prior to sampling.

8.2.2.3 To the beaker containing sample, add 13.3 g of TCE (40 % dilution of the test sample with TCE). Mix the solution thoroughly, using the glass rod.

NOTE 5—For some samples, it is necessary to heat and stir until the sample is completely homogeneous. Maintain the liquid level with additional TCE during heating if necessary.

8.2.2.4 Continue as in 8.2.1.4 through 8.2.1.8.

#### 8.3 Test Method C—Residue

8.3.1 Take a clean and dry test cell with PTFE plug, a 150-mL beaker, and a glass rod. Weigh each of them to the nearest 0.001 g, and record as tare weights.

8.3.2 Add 15 g of reference standard or test specimen to the beaker. Record this mass to the nearest 0.001 g as  $S_M$ . All samples shall be homogeneous prior to sampling. If the sample is viscous or contains waxy materials, heat the sample in its container to approximately 60°C and mix with a high-speed shear mixer prior to sampling.

8.3.3 To the beaker, add 17.2 g of TCE and 5.3 g of relaxation reagent solution (60 % dilution with 1 mg of relaxation reagent per 1 mL). Mix thoroughly using the glass stirring rod (see 6.4).

8.3.4 Continue, as described in 8.2.1.4 through 8.2.1.8.

## 9. Preparation of Apparatus

9.1 Read and follow the manufacturer's instructions for preparing the instrument to take measurements. Take special care to prevent the instrument and conditioning block from experiencing rapid temperature fluctuations; for example, avoid direct sunlight and drafts resulting from air conditioning or fans.

9.2 Adequate temperature equilibration of the instrument probe assembly after adjustment to an elevated temperature is essential. Due to the size of test specimen and probe assembly specified by these methods, adequate thermal equilibration may require several hours.

9.3 The results obtained during the use of the instrument are susceptible to error arising from changes in the local magnetic environment. Exercise care to ensure that there is a minimum of metallic material in the immediate vicinity of the instrument and keep this constant throughout the course of a series of determinations.

9.4 Set the instrument controls to the following conditions:

| Parameter                         | Test Method | Test Method | Test Method |
|-----------------------------------|-------------|-------------|-------------|
|                                   | A           | B           | C           |
| Gate width (G)                    | 1.5         | 1.5         | 1.5         |
| Audio-Frequency Gain (Arb. units) | 500         | 400–600     | 400–600     |
| Radio-frequency Excitation (μA)   | 20          | 20          | 20          |
| Integration Time (seconds)        | 128         | 128         | 128         |
| Probe Temperature (°C)            | Room Temp   | 50          | 50          |

9.5 Place a test cell containing typical test specimen in the coil and ensure that the tuning of the instrument results in two coincident resonance curves on the oscilloscope. Recheck this condition after changing samples.

9.6 Remove the test cell from the coil, and observe that the signal readout from the instrument integrator is now  $0 \pm 3$  units. Check this condition periodically to ensure that no contamination of the coil with hydrogen-containing material has occurred.

## 10. Procedures

### 10.1 Test Methods A, B, and C:

10.1.1 Leave the reference standard and the test specimens in the conditioning block for at least 0.5 h, to ensure that they reach the specified test temperature. The temperature of the conditioning block shall be maintained at the same temperature required for the NMR measurement as specified in 9.4.

10.1.2 Read the following instructions in conjunction with the procedure provided in the manufacturer's handbook for analyzing samples. Specific steps may vary with instrument manufacturer and model. In cases where the manufacturer's instructions differ from the following steps, follow the manufacturer's instructions.

**TABLE 1 Repeatability (*r*) and Reproducibility (*R*) Precision Intervals for Test Methods A, B, and C in Units of Mass Percent Hydrogen**

| mass %<br>H | Test Method A |          | Test Method B |          | Test Method C |          |
|-------------|---------------|----------|---------------|----------|---------------|----------|
|             | <i>r</i>      | <i>R</i> | <i>r</i>      | <i>R</i> | <i>r</i>      | <i>R</i> |
| 9.00        | 0.13          | 0.42     | 0.12          | 0.25     | 0.41          | 0.87     |
| 9.25        | 0.13          | 0.41     | 0.13          | 0.27     | 0.39          | 0.82     |
| 9.50        | 0.13          | 0.41     | 0.14          | 0.28     | 0.37          | 0.78     |
| 9.75        | 0.12          | 0.41     | 0.14          | 0.29     | 0.35          | 0.74     |
| 10.00       | 0.12          | 0.40     | 0.15          | 0.31     | 0.33          | 0.70     |
| 10.25       | 0.12          | 0.40     | 0.16          | 0.33     | 0.32          | 0.67     |
| 10.50       | 0.12          | 0.40     | 0.17          | 0.34     | 0.30          | 0.64     |
| 10.75       | 0.12          | 0.40     | 0.17          | 0.36     | 0.29          | 0.61     |
| 11.00       | 0.12          | 0.40     | 0.18          | 0.38     | 0.28          | 0.58     |
| 11.25       | 0.12          | 0.39     | 0.19          | 0.39     | 0.26          | 0.56     |
| 11.50       | 0.12          | 0.39     | 0.20          | 0.41     | 0.25          | 0.53     |
| 11.75       | 0.12          | 0.39     | 0.21          | 0.43     | 0.24          | 0.51     |
| 12.00       | 0.12          | 0.39     | 0.22          | 0.45     | 0.23          | 0.49     |
| 12.25       | 0.12          | 0.38     | 0.23          | 0.47     | 0.22          | 0.47     |
| 12.50       | 0.12          | 0.38     | 0.23          | 0.48     | 0.21          | 0.45     |
| 12.75       | 0.12          | 0.38     | 0.24          | 0.50     | 0.20          | 0.43     |
| 13.00       | 0.12          | 0.38     | 0.25          | 0.52     | 0.20          | 0.42     |
| 13.25       | 0.12          | 0.38     | 0.26          | 0.54     | 0.19          | 0.40     |
| 13.50       | 0.11          | 0.38     | 0.27          | 0.56     | 0.18          | 0.39     |
| 13.75       | 0.11          | 0.37     | 0.28          | 0.59     | 0.18          | 0.37     |
| 14.00       | 0.11          | 0.37     | 0.29          | 0.61     | 0.17          | 0.36     |
| 14.25       | 0.11          | 0.37     | 0.30          | 0.63     | 0.16          | 0.35     |
| 14.50       | 0.11          | 0.37     | 0.32          | 0.65     | 0.16          | 0.33     |
| 14.75       | 0.11          | 0.37     | 0.33          | 0.67     | 0.15          | 0.32     |
| 15.00       | 0.11          | 0.37     | 0.34          | 0.70     | 0.15          | 0.31     |
| 15.25       | 0.11          | 0.36     | 0.35          | 0.72     | 0.14          | 0.30     |
| 15.50       | 0.11          | 0.36     | 0.36          | 0.74     | 0.14          | 0.29     |
| 15.75       | 0.11          | 0.36     | 0.37          | 0.77     | 0.13          | 0.28     |
| 16.00       | 0.11          | 0.36     | 0.38          | 0.79     | 0.13          | 0.27     |

10.1.3 Take the reference standard and place it carefully into the instrument sample probe (coil), being careful that the liquid does not splash onto the under side of the PTFE plug. When fully inserted, the top of the test cell is just above the cover of the instrument unit.

10.1.4 Check that the peaks on the oscilloscope are coincident, and if this is not so, adjust the tuning, as described by the manufacturer's instructions, until they are.

10.1.5 After the reference standard is in the magnet unit for at least 3 s, push the reset button to begin a measurement.

10.1.6 After a count time of 128 s, the digital display stops at its final value. Record the integrator counts, and reset the instrument to take a second measurement. Record a total of seven readings, averaging the last five.

10.1.7 Remove the test cell containing reference standard from the instrument and reweigh after it has cooled to room temperature. If this mass differs significantly from the mass obtained in 8.1.4 or 8.2.1.6, the PTFE plug need not have sealed properly and the result is considered suspect. This additional weighing step is required due to the presence of the TCE diluent in some samples.

10.1.8 Replace the reference standard in the conditioning block, and make similar readings on the test specimen to be tested.

NOTE 6—Measurements are affected by temperature variations in the sample and reference standard so these test cells are always returned to the conditioning block if additional measurements are anticipated on the same sample.

## 11. Calculation

11.1 Determination of the mass of test specimen or reference material delivered to the NMR test cell. This calculation accounts for the dilution with TCE and the loss of material during the transfer to the test cell.

11.1.1 Test Method A—Not applicable.

11.1.2 Test Methods B and C:

$$M_R \text{ or } M_S = S_M \times (M_1)/(M_1 + M_2) \quad (1)$$

where:

- $M_R$  or  $M_S$  = mass of reference material or test specimen in the test cell,
- $S_M$  = mass of standard or test specimen in the preparation beaker,
- $M_1$  = mass of solution in the NMR test cell, and
- $M_2$  = mass of solution remaining in the preparation beaker.

11.2 Hydrogen Content:

11.2.1 Calculate mass % hydrogen content as follows: Hydrogen Content (mass)

$$(S/R) \times (M_R/M_S) \times (15.39) \quad (2)$$

where:

- $S$  = mean of integrator counts on test specimen under test,
- $R$  = mean of integrator counts on reference standard,
- $M_R$  = mass of reference standard in the test cell,
- $M_S$  = mass of test specimen in the test cell, and,

15.39 = mass hydrogen in the reference sample, *n*-dodecane.

## 12. Report

12.1 Report the mass % hydrogen content on the test sample to the nearest 0.01 mass hydrogen.

## 13. Precision and Bias <sup>5</sup>

13.1 The precision of this test method as obtained by statistical examination of interlaboratory test results is as follows:

13.1.1 *Repeatability*—The difference between successive test results obtained by the same operator with the same apparatus under constant operating conditions on identical test material would, in the long run, in the normal and correct operation of the test method, exceed the following value only in one case in twenty (see Table 1):

|   |                    |
|---|--------------------|
| Test Method A—Light Distillates               | 0.22( $X^{0.25}$ ) |
| Test Method B—Middle Distillates and Gas Oils | 0.0015( $X^2$ )    |
| Test Method C—Residua                         | 33.3( $X^{-2}$ )   |

<sup>5</sup> Supporting data are available from ASTM International Headquarters. Request RR:D02-1186.

where *X* is the sample mean.

13.1.2 *Reproducibility*—The difference between two single and independent results obtained by different operators working in different laboratories on identical test material would, in the long run, in the normal and correct operation of the test method, exceed the following value in one case in twenty (see Table 1):

|   |                    |
|---|--------------------|
| Test Method A—Light Distillates               | 0.72( $X^{0.25}$ ) |
| Test Method B—Middle Distillates and Gas Oils | 0.0031( $X^2$ )    |
| Test Method C—Residua                         | 70.3( $X^{-2}$ )   |

where *X* is the sample mean.

## 13.2 Bias:

13.2.1 A 1985 research report indicated that the hydrogen content determined by Test Methods A, B, and C are not biased with respect to data obtained by combustion techniques.

13.2.2 A 1977 research report indicated that the hydrogen content determined by Test Method A (same as Test Method D 3701) is biased high with respect to the expected value for pure known hydrocarbons.

## 14. Keywords

14.1 distillate; gas oil; hydrogen content; light distillate; middle distillate; nuclear magnetic; petroleum products; residua; resonance spectroscopy

## SUMMARY OF CHANGES

Sub-Committee D02.03 has identified the location of selected changes to this standard since the last issue (D 4808 – 98) that may impact the use of this standard.

- (1) Updated information in Note 1 to reflect that the Newport 4000 instrument is no longer being manufactured currently for use in the test.
- (2) Inserted a new paragraph 10.1.2 to instruct the user to follow the instructions from the vendor in the Procedure

section, similar to instructions already in the method in Section 9 (Preparation of Apparatus) that refers the user to the manufacturer's handbook.

*ASTM International takes no position respecting the validity of any patent rights asserted in connection with any item mentioned in this standard. Users of this standard are expressly advised that determination of the validity of any such patent rights, and the risk of infringement of such rights, are entirely their own responsibility.*

*This standard is subject to revision at any time by the responsible technical committee and must be reviewed every five years and if not revised, either reapproved or withdrawn. Your comments are invited either for revision of this standard or for additional standards and should be addressed to ASTM International Headquarters. Your comments will receive careful consideration at a meeting of the responsible technical committee, which you may attend. If you feel that your comments have not received a fair hearing you should make your views known to the ASTM Committee on Standards, at the address shown below.*

*This standard is copyrighted by ASTM International, 100 Barr Harbor Drive, PO Box C700, West Conshohocken, PA 19428-2959, United States. Individual reprints (single or multiple copies) of this standard may be obtained by contacting ASTM at the above address or at 610-832-9585 (phone), 610-832-9555 (fax), or service@astm.org (e-mail); or through the ASTM website (www.astm.org).*