



Standard Test Method for Cleanliness and Compatibility of Residual Fuels by Spot Test¹

This standard is issued under the fixed designation D 4740; the number immediately following the designation indicates the year of original adoption or, in the case of revision, the year of last revision. A number in parentheses indicates the year of last reapproval. A superscript epsilon (ϵ) indicates an editorial change since the last revision or reapproval.

1. Scope

1.1 This test method describes separate procedures for determining the cleanliness of residual fuel oil and the compatibility of a residual fuel oil with a blend stock. It is applicable to residual fuel oils with viscosities up to 50 cSt (1 cSt = 1 mm²/s) at 100°C.

1.2 The values stated in SI units are to be regarded as the standard. The inch-pound units given in parentheses are for information only.

1.3 *This standard does not purport to address all of the safety concerns, if any, associated with its use. It is the responsibility of the user of this standard to establish appropriate safety and health practices and determine the applicability of regulatory limitations prior to use.*

2. Referenced Documents

2.1 ASTM Standards:

D 4057 Practice for Manual Sampling of Petroleum and Petroleum Products²

D 4177 Practice for Automatic Sampling of Petroleum and Petroleum Products²

E 1 Specification for ASTM Thermometers³

2.2 ASTM Adjuncts:

Reference Spot Sheet (D 4740)⁴

3. Terminology

3.1 Descriptions of Terms Specific to This Standard:

3.1.1 *blend stock, n*—a finished residual fuel oil or fuel oil component, including petroleum streams ranging from kerosine to residuals and asphalt.

3.1.2 *cleanliness, n*—of residual fuel, the absence of suspended solids in a finished sample.

3.1.3 *compatibility, n*—of residual fuel, the absence of suspended solids when equal volumes of a sample and a blend stock are mixed together.

4. Summary of Test Method

4.1 *Cleanliness Procedure*—A drop of the preheated and thoroughly mixed sample is put on a test paper and placed in an oven at 100°C. After 1 h, the test paper is removed from the oven and the resultant spot is examined for evidence of suspended solids and rated for cleanliness using the D 4740 Adjunct Reference Spots.

4.2 *Compatibility Procedure*—A blend composed of equal volumes of the sample fuel oil and the blend stock is tested in the same way as described in 4.1 and rated for compatibility against D 4740 Adjunct Reference Spots.

5. Significance and Use

5.1 The two procedures in this test method are used alone or in combination to identify fuels or blends that could result in excessive centrifuge loading, strainer plugging, tank sludge formation, or similar operating problems.

5.2 A spot rating of Number 3 or higher on a finished fuel oil by the cleanliness procedure indicates that the fuel contains excessive suspended solids and is likely to cause operating problems.

5.3 Although a fuel may test clean when subjected to the cleanliness procedure, suspended solids may precipitate when the fuel is mixed with a blend stock. Evidence of such incompatibility is indicated by a spot rating of Number 3 or higher in the compatibility procedure.

6. Apparatus

6.1 *Test Paper*—Chromatographic paper cut or divided into appropriately sized squares, strips, or circles. Store the paper, without folding, rolling, or bending, in a tightly closed container.⁵

6.2 *Test Paper Support*—Fig. 1 shows a suitable support for multiple samples spotted on the same test paper which shall be supported in a horizontal position so nothing touches test areas of the paper.

6.3 *Oven*—Any convection oven capable of maintaining an air temperature of 100 ± 2°C.

¹ This test method is under the jurisdiction of ASTM Committee D02 on Petroleum Products and Lubricants and is the direct responsibility of Subcommittee D02.14 on Stability and Cleanliness of Liquid Fuels.

Current edition approved June 10, 2002. Published August 2002. Originally published as D 4740–92. Last previous edition D 4740–95.

² *Annual Book of ASTM Standards*, Vol 05.02.

³ *Annual Book of ASTM Standards*, Vol 14.03.

⁴ Available from ASTM Headquarters. Order Adjunct No. ADJD4740.

⁵ The sole source of supply of Whatman paper No. 2 known to the committee at this time is Whatman, Inc., 9 Bridewell Place, Clifton, NJ 07014. If you are aware of alternative suppliers, please provide this information to ASTM International Headquarters. Your comments will receive careful consideration at a meeting of the responsible technical committee¹, which you may attend.

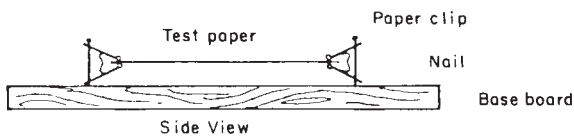
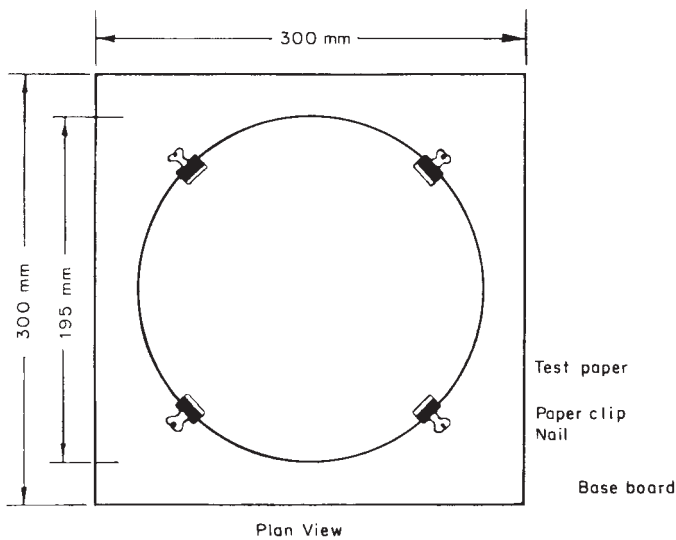

FIG. 1 Support for Test Paper

6.4 Reference Spot Sheet—Adjunct for D 4740.

6.5 Conical Flask, 100-mL capacity.

6.6 Heating Bath or Hot Plate, capable of heating sample to a temperature between 90 and 95°C.

6.7 Thermometer, general purpose Specification E 1 or equivalent.

7. Sampling

7.1 Samples for this test can come from tanks, lines, drums, or small containers. Use the applicable apparatus and techniques described in Practices D 4057 or D 4177.

8. Cleanliness Procedure

8.1 Heat the sample in the original container in the heating bath or on a hot plate to above 90° to ensure the sample is in a fluid state.

8.2 Mix thoroughly.

NOTE 1—Mechanical shaking or mechanical mixing is recommended.

8.3 Pour approximately 50 mL of the sample into a 100-mL conical flask and place the flask in the heating bath or on a hot plate.

8.4 Heat the sample uniformly by stirring and maintain the sample temperature between 90 and 95°C for 15 to 20 min.

8.5 Position the test paper so the test portion is clear of any support (Fig. 1) and place in the oven for a minimum of 5 min allowing the paper temperature to attain the oven temperature.

8.6 Preheat the glass rod by dipping into and stirring the heated sample for about 20 s. Withdraw the rod and allow the first drop to fall back into the conical flask. Allow the second

drop to fall onto the test paper which is supported horizontally in the oven heated to a temperature of 100°C.

8.6.1 A number of samples may be spotted on the same test paper. The spot centers must not be closer than 50 mm and at least 25 mm from the edge of the test paper.

8.7 Dry the test paper in the oven maintained at 100 ± 2°C for 1 h. The test paper must be kept level and supported in such a manner to prevent the spotted portion from coming into contact with any surface.

8.8 After 1 h, remove the test paper from the oven. Refer to the reference spot adjunct and to the reference spot descriptions given in Table 1. Compare the spot with the standard spots on the adjunct and record the spot number having the closest resemblance. If the sample spot is rated between two consecutive spots on the adjunct, record the larger number.

NOTE 2—Ignore differences in overall darkness, color, size, and appearance of the outer edges.

9. Compatibility Procedure

9.1 Pour 30 mL of test sample in an appropriate container, heating if necessary.

9.2 Add an equal volume of blend stock to the test sample and mix the contents thoroughly.

9.3 The equal volume of blend is generally the most severe condition for measuring compatibility. If in actual practice an application requires a blending ratio other than equal parts, conduct the test using the actual blend ratio for the test results to have a good probability of being indicative of the final blend.

9.4 Immediately test 50 mL of the mixture as described in 8.3-8.8.

10. Report

10.1 Report the cleanliness or the compatibility rating as an integer from 1 to 5 as determined in 8.8. Report the blend ratio when other than 50:50 is used to determine the capability rating.

11. Precision and Bias

11.1 Precision and bias statements have not been determined for the preparation of the spots; however, a precision statement regarding how different individuals rate spots was determined by a modified round robin test. The need for statements pertaining to the preparation of the spots is being considered.

11.1.1 The precision of the procedure in Test Method D 4740, for different individuals using the same D 4740

TABLE 1 Reference Spot Description

Reference Spot No.	Characterizing Features
1	Homogeneous spot (no inner ring)
2	Faint or poorly defined inner ring
3	Well-defined thin inner ring, only slightly darker than the background
4	Well-defined inner ring, thicker than the ring in reference spot No. 3 and somewhat darker than the background
5	Very dark solid or nearly solid area in the center. The central area is much darker than the background

Adjunct Reference Spots in conjunction with Table 1 to rate the same spots prepared in accordance with Test Method D 4740 from field samples, as determined at a common site is as follows:

11.1.1.1 *Repeatability*—The difference between successive ratings of the same spot by the same individual viewed under same conditions would, in the long run, not exceed one rating number only in one case in twenty.

11.1.1.2 *Reproducibility*—The difference between two single independent ratings obtained by different individuals for

the same spot viewed under the same conditions would, in the long run, not exceed one rating number only in one case in twenty.

11.2 *Bias*—Since there is no accepted reference material suitable for preparing the spots used in the spot rating procedures in Test Method D 4740, bias has not been determined.

12. Keywords

12.1 cleanliness; compatibility; residual fuel; spot test

ASTM International takes no position respecting the validity of any patent rights asserted in connection with any item mentioned in this standard. Users of this standard are expressly advised that determination of the validity of any such patent rights, and the risk of infringement of such rights, are entirely their own responsibility.

This standard is subject to revision at any time by the responsible technical committee and must be reviewed every five years and if not revised, either reapproved or withdrawn. Your comments are invited either for revision of this standard or for additional standards and should be addressed to ASTM International Headquarters. Your comments will receive careful consideration at a meeting of the responsible technical committee, which you may attend. If you feel that your comments have not received a fair hearing you should make your views known to the ASTM Committee on Standards, at the address shown below.

This standard is copyrighted by ASTM International, 100 Barr Harbor Drive, PO Box C700, West Conshohocken, PA 19428-2959, United States. Individual reprints (single or multiple copies) of this standard may be obtained by contacting ASTM at the above address or at 610-832-9585 (phone), 610-832-9555 (fax), or service@astm.org (e-mail); or through the ASTM website (www.astm.org).