



Designation: D 473 – 02

An American National Standard



Designation: Manual of Petroleum Measurement Standards (MPMS), Chapter 10.1

Designation: 53/82

## Standard Test Method for Sediment in Crude Oils and Fuel Oils by the Extraction Method<sup>1</sup>

This standard is issued under the fixed designation D 473; the number immediately following the designation indicates the year of original adoption or, in the case of revision, the year of last revision. A number in parentheses indicates the year of last reapproval. A superscript epsilon ( $\epsilon$ ) indicates an editorial change since the last revision or reapproval.

*This standard has been approved for use by agencies of the Department of Defense.*

### 1. Scope

1.1 This test method covers the determination of sediment in crude oils and fuel oils by extraction with toluene. The precision applies to a range of sediment levels from 0.01 to 0.40 % mass, although higher levels may be determined.

NOTE 1—Precision on recycled oils and crank case oils is unknown and additional testing is required to determine that precision.

1.2 The values stated in SI units are to be regarded as the standard. The values given in parentheses are for information only.

1.3 *This standard does not purport to address all of the safety concerns, if any, associated with its use. It is the responsibility of the user of this standard to establish appropriate safety and health practices and determine the applicability of regulatory limitations prior to use.* For specific precautionary statements, see 6.1.

### 2. Referenced Documents

#### 2.1 ASTM Standards:

D 4057 Practice for Manual Sampling of Petroleum and Petroleum Products<sup>2</sup>

D 4177 Practice for Automatic Sampling of Petroleum and Petroleum Products<sup>2</sup>

D 5854 Practice for Mixing and Handling of Liquid Samples of Petroleum and Petroleum Products<sup>3</sup>

#### 2.2 API Standards:<sup>4</sup>

Chapter 8.1 Manual Sampling of Petroleum and Petroleum

Products (ASTM Practice D 4057)

Chapter 8.2 Automatic Sampling of Petroleum and Petroleum Products (ASTM Practice D 4177)

Chapter 8.3 Mixing and Handling of Liquid Samples of Petroleum and Petroleum Products (ASTM Practice D 5854)

#### 2.3 ISO Standard:<sup>5</sup>

5272 Toluene for industrial use—Specifications

### 3. Summary of Test Method

3.1 Extract test portion of a representative oil sample, contained in a refractory thimble, with hot toluene until the residue reaches constant mass. The mass of residue, calculated as a percentage, is reported as *sediment by extraction*.

### 4. Significance and Use

4.1 A knowledge of the sediment content of crude oils and fuel oils is important both to the operation of refining and the buying or selling of these commodities.

### 5. Apparatus

5.1 Usual laboratory apparatus and glassware, together with the following are required for this test method.

5.1.1 *Extraction Apparatus*—Use the apparatus illustrated in Figs. 1 and 2 and consisting of the elements described in 5.1.1.1–5.1.1.3.

5.1.1.1 *Extraction Flask*—Use a wide-neck (Erlenmeyer) flask of 1-L capacity, with a minimum external neck diameter of 50 mm, for the procedure.

5.1.1.2 *Condenser*—A condenser in the form of a metal coil approximately 25 mm in diameter and 50 mm in length attached to, and with the ends projecting through, a lid of sufficient diameter to cover the neck of the flask as shown in Fig. 1. The coil shall be made from stainless steel, tin,

<sup>1</sup> This test method is under the jurisdiction of ASTM Committee D02 on Petroleum Products and Lubricants and the API Committee on Petroleum Measurement, and is the direct responsibility of Subcommittee D02.02/COMQ, the joint ASTM-API Committee on Static Petroleum Measurement.

Current edition approved April 10, 2002. Published August 2002. Originally published as D 473–38T. Last previous edition D 473–81(1995) $\epsilon$ 2.

<sup>2</sup> *Annual Book of ASTM Standards*, Vol 05.02.

<sup>3</sup> *Annual Book of ASTM Standards*, Vol 05.03.

<sup>4</sup> Published as Manual of Petroleum Measurement Standards. Available from the American Petroleum Institute (API), 1220 L St., NW, Washington, DC 20005.

<sup>5</sup> Available from American National Standards Institute (ANSI), 25 W. 43rd St., 4th Floor, New York, NY 10036.

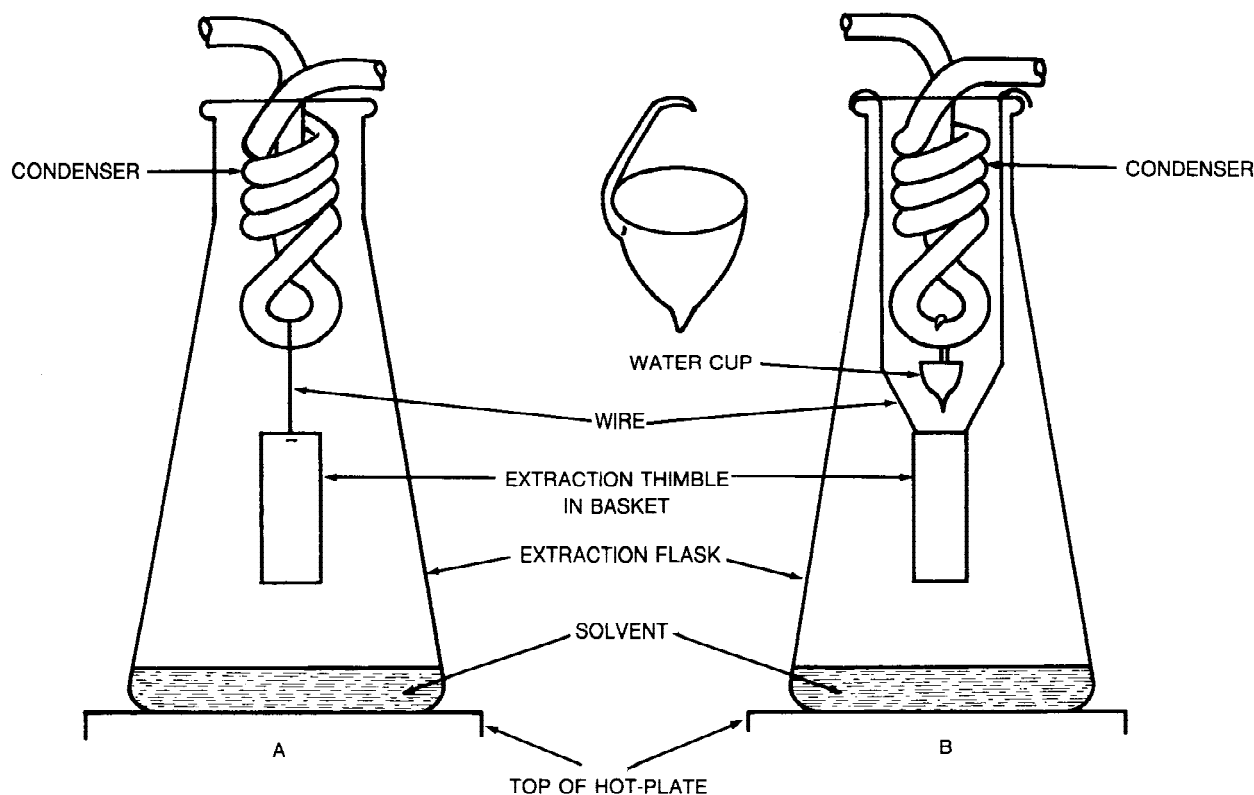

NOTE—Apparatus B shows the water cup in position.  
**FIG. 1 Extraction Apparatus for Determination of Sediment**

tin-plated copper, or tin-plated brass tubing having an outside diameter of 5 to 8 mm and a wall thickness of 1.5 mm. If constructed of tin-plated copper or brass, the tin coating shall have a minimum thickness of 0.075 mm. The exposed surface of the coil for cooling purposes is about 115 cm<sup>2</sup>.

5.1.1.3 *Extraction Thimble*<sup>6</sup>—The extraction thimble shall be of a refractory porous material, pore size 20.0 to 30.0 μm (as certified by the manufacturer), 25 mm in diameter by 70 mm in height, weighing not less than 15 g and not more than 17 g. Suspend the thimble from the condenser coil by means of a basket so that it hangs approximately midway between the surface of the extracting solvent and the bottom of the condenser coil.

5.1.1.4 *Thimble Basket*—The thimble basket shall be corrosion-resistant, shall be made of platinum, stainless steel, nickel-chromium alloy, or similar material, and shall meet the design and dimension requirements in Fig. 2.

5.1.1.5 *Water Cup*—Use a water cup when testing a sample determined to have a water content greater than 10 % volume (see Fig. 1, Apparatus B). The cup shall be made of glass, conical in shape, approximately 20 mm in diameter and 25 mm deep, and have a capacity of approximately 3 mL. A glass hook

fused on the rim at one side is so shaped that when hung on the condenser the cup hangs with its rim reasonably level. In this procedure, suspend the thimble basket as shown in Fig. 1, Apparatus A by means of the corrosion-resistant wire looped over the bottom of the condenser coil and attached to the basket supports, or as in Fig. 1, Apparatus B, where the wire supports of the basket are attached to hooks soldered to the underside of the condenser lid.

5.1.1.6 *Source of Heat*—Use a source of heat, preferably a hot plate operated under a ventilated hood, suitable for vaporizing toluene (**Warning—Flammable.**)

5.2 *Analytical Balance*—Use an analytical balance, with an accuracy of 0.1 mg. Verify the balance, at least annually, against weights traceable to a national standards body such as the National Institute of Standards and Technology (NIST).

5.3 *Non-aerating Mixer*—Use a non-aerating mixer, meeting the verification of mixing efficiency requirements specified in Practice D 5854 (API Chapter 8.3). Either insertion mixers or circulating mixers or circulating external mixers are acceptable provided they meet the criteria in Practice D 5854 (API Chapter 8.3).

5.4 *Oven*—Use an oven capable of maintaining a temperature of 115 to 120°C (240 to 250°F).

5.5 *Cooling Vessel*—Use a desiccator without desiccant as a cooling vessel.

5.6 *Thermometer*—Use a thermometer capable of measuring the temperature of the sample to the nearest 1°C (2°F).

<sup>6</sup> The sole source of supply of the extraction thimble, AN 485, 25 × 70-mm, coarse porosity, drawing number QA 005163, known to the committee at this time is Saint-Gobain/Norton Industrial Ceramics Corporation of Worcester, MA. If you are aware of alternative suppliers, please provide this information to ASTM International Headquarters. Your comments will receive careful consideration at a meeting of the responsible technical committee<sup>1</sup>, which you may attend.

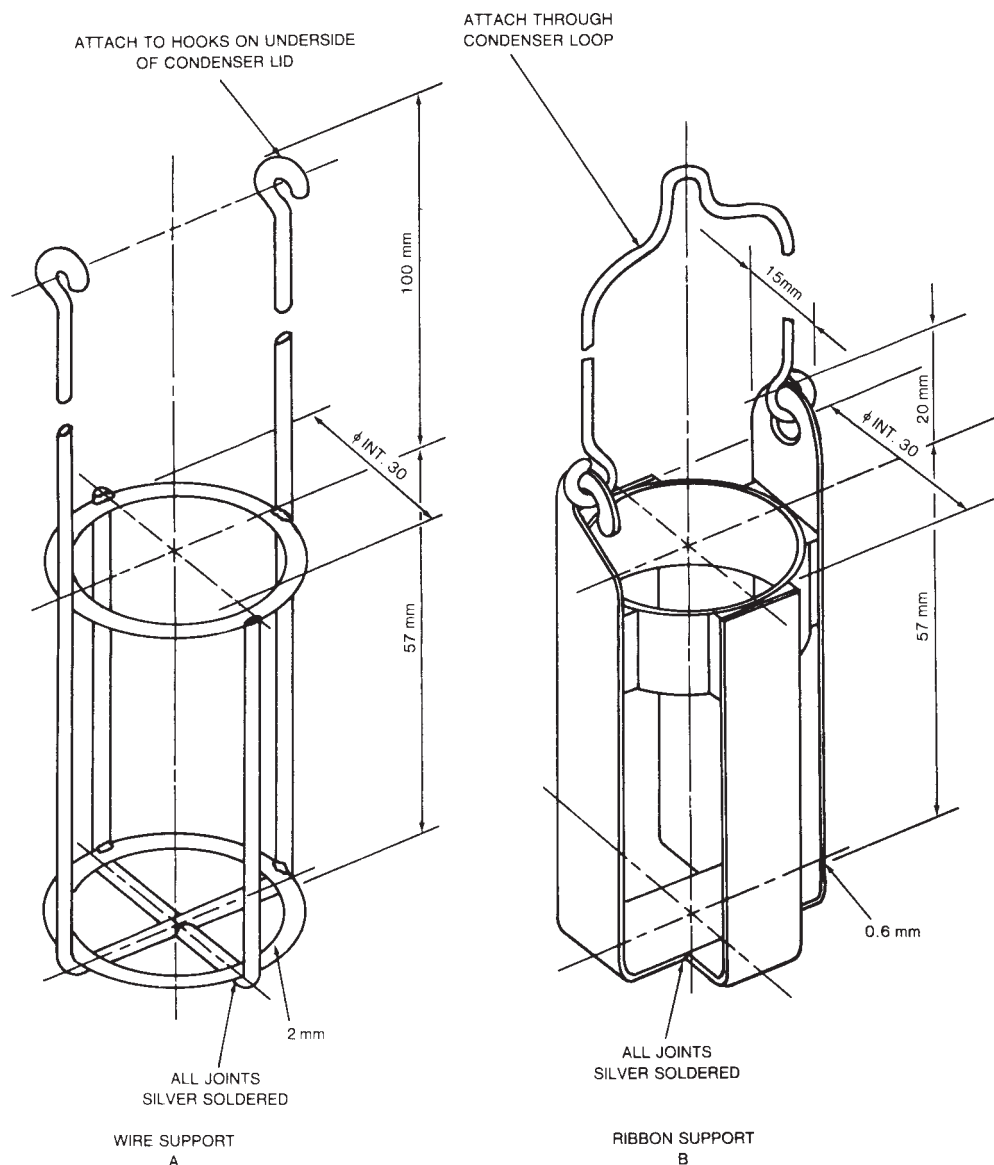

FIG. 2 Basket Thimble Support

## 6. Solvent

6.1 *Toluene*—Reagent grade conforming to the specifications of the Committee on Analytical Reagents of the American Chemical Society (ACS)<sup>7</sup> or to Grade 2 of ISO 5272. (**Warning**—Flammable. Keep away from heat, sparks and open flame. Vapor harmful. Toluene is toxic. Particular care shall be taken to avoid breathing the vapors and to protect the eyes. Keep the container closed. Use with adequate ventilation. Avoid prolonged or repeated contact with the skin.)

6.1.1 The typical characteristics for the ACS reagent are shown in Table 1.

TABLE 1 Typical Characteristics for ACS Reagent Grade Toluene

Assay	99.5+ %
Color (APHA)	10
Boiling range (initial to dry point) <sup>A</sup>	2.0°C
Residue after evaporation	0.001 %
Substances darkened by H <sub>2</sub> SO <sub>4</sub>	passes test
Sulfur compounds (as S)	0.003 %
Water (H <sub>2</sub> O) (by Karl Fischer titration)	0.03 %

<sup>A</sup> Recorded boiling point 110.6°C.

## 7. Sampling

7.1 Sampling shall include all steps required to obtain an aliquot of the contents of any pipe, tank, or other system and to place the sample into the laboratory test container.

7.2 Only use representative samples obtained as specified in Practices D 4057 (API Chapter 8.1) and D 4177 (API Chapter 8.2) for this test method.

7.3 Draw test portions from the laboratory samples immediately after thorough mixing. Heat viscous samples to a temperature which renders the sample liquid, and homogenize

<sup>7</sup> *Reagent Chemicals, American Chemical Society Specifications*, American Chemical Society, Washington, DC. For suggestions on the testing of reagents not listed by the American Chemical Society, see *Analar Standards for Laboratory Chemicals*, BDH Ltd., Poole, Dorset, U.K., and the United States Pharmacopeia and National Formulary, U.S. Pharmacopeial Convention, Inc., (USPC), Rockville, MD 20852.

using a mixer as described in 5.3, as necessary. The difficulties of obtaining a representative test portion for this determination are usually great, hence the need for great attention to the mixing and aliquoting steps.

7.4 As specified in Practice D 5854 (API Chapter 8.3), record the temperature of the sample before mixing. Mix the laboratory sample in its original container, using the mixing time, mixing power (speed), and position relative to the bottom of the container appropriate to the crude petroleum or fuel oil being analyzed, and as established by the verification of mixing efficiency. To avoid the loss of light ends from crude oil or other samples containing volatile material, operate the mixer through a gland in the closure of the sample container. Take the test portion for analysis immediately after mixing. Record the temperature of the sample immediately after mixing. If the rise in temperature during mixing exceeds 10°C (20°F), cool the sample, and repeat the mixing at a lower energy input. A rise in temperature greater than 10°C (20°F) may result in a decrease in viscosity that is sufficient for the sediment to settle.

## 8. Procedure

8.1 For referee tests, use a new extraction thimble (5.1.1.3) prepared in accordance with 8.2. For routine tests, thimbles may be reused. When reusing thimbles, the extraction to constant mass for one determination should be considered as the preliminary extraction for the succeeding determination. After several determinations (the accumulated sediment may be sufficient to interfere with further determinations), follow the procedure described in 8.3 to remove the combustible portion of the accumulated sediment. Avoid excessive reuse of thimbles, as over time the pores become clogged with inorganic material resulting in falsely high results. When in doubt regarding a higher than normal result, discard the thimble and retest using a new thimble.

8.2 *Preparation of a New Thimble*—Rub the outside surface with fine sandpaper and remove all loosened material with a stiff brush. Give the thimble a preliminary extraction with the toluene, allowing the solvent to drip from the thimble for at least 1 h. Then dry the thimble for 1 h at a temperature of 115 to 120°C (240 to 250°F); cool in a cooling vessel, for 1 h, and weigh to the nearest 0.1 mg. Repeat the extraction until the masses of the thimble after two successive extractions do not differ by more than 0.2 mg.

8.3 *Preparation of a Used Thimble*—Remove the combustible portion of the accumulated sediment by heating the thimble to a dull red heat for 20 min (preferably in an electric furnace maintained at approximately 750°C (1380°F)). Subject the thimble to a preliminary extraction as described in 8.2 before using it for another determination.

8.4 Place an estimated 10-g test portion of the sample in the thimble immediately after the sample has been mixed. Do not attempt to adjust this estimated 10-g portion to any exact predetermined amount. Weigh the thimble plus test portion to the nearest 0.01 g. Add 150 mL to 200 mL of toluene to the flask. Place the thimble in the extraction apparatus, place on the heat source, and extract with the hot toluene for 30 min after the solvent dripping from the thimble becomes colorless. Ensure that the rate of extraction is such that the surface of the mixture of oil and toluene in the thimble does not rise higher

than to within 20 mm of the top.

8.5 When testing samples determined to have a water content greater than 10 % volume, use the assembly shown in Fig. 1, Apparatus B. In this procedure, remove any water in the test portion as its toluene azeotrope and is collected in the water cup, where it separates as a bottom layer. The toluene layer overflows into the thimble. If the cup becomes full of water, allow the apparatus to cool and empty the cup.

8.6 After the extraction is completed, dry the thimble for 1 h at 115 to 120°C (240 to 250°F) in the oven; cool in the cooling vessel, for 1 h; and weigh to the nearest 0.1 mg.

8.7 Repeat the extraction, allowing the solvent to drip from the thimble for at least 1 h but not longer than 1.25 h; dry, cool, and weigh the thimble as described in 8.6. Repeat this extraction for further 1-h periods, if necessary, until the masses of the dried thimble plus sediment after two successive extractions do not differ by more than 0.2 mg.

## 9. Calculation

9.1 Calculate the sediment content of the sample as a percentage by mass of the original sample.

$$S = \frac{m_3 - m_1}{m_2 - m_1} \times 100 \quad (1)$$

where:

$S$  = sediment content of the sample as a percentage by mass,

$m_1$  = mass, of the thimble, g,

$m_2$  = mass, of the thimble plus test portion, g, and

$m_3$  = mass of the thimble plus sediment, g.

## 10. Report

10.1 Report the sediment content of the sample, as *sediment by extraction*, as a percentage by mass, rounded to the nearest 0.01 % mass. The test result shall reference Test Method D 473/API MPMS Chapter 10.1 as the procedure used.

NOTE 2—Since water and sediment values are commonly reported as volume percent, calculate the volume of the sediment as a percentage of the original sample. As a major portion of the sediment probably would be sand (silicon dioxide, which has a density of 2.32) and a small amount of other naturally occurring materials (with a relative density lower than that of sand), use an arbitrary density of 2.0 for the resulting sediment. Then, to obtain volume percent sediment, divide the mass percent sediment by 2.0 and multiply by the relative density of the crude or fuel oil.

$$S_v = \frac{S}{2.0} \times \text{relative density of the oil} \quad (2)$$

where:

$S_v$  = sediment content of the sample as a percentage by volume, and

$S$  = sediment content of the sample as a percentage by mass.

10.2 Report that the sample mixing procedure was performed in accordance with the procedures specified in Practice D 5854 (API Chapter 8.3). Report the temperature of the sample before and after mixing.

10.3 The test report shall also contain all details necessary for complete identification of the product tested; any deviation, by agreement or otherwise, from the procedure specified; and the date of the test.

## 11. Precision and Bias

11.1 *Precision*—The precision of the test method, as based

on mass percent and as obtained by statistical examination of interlaboratory test results in the range 0 to 0.4 %, is described in 11.1.1 and 11.1.2.

11.1.1 *Repeatability*—The difference between successive test results, obtained by the same operator with the same apparatus under constant operating conditions on identical test material, would, in the long run, in the normal and correct operation of the test method, exceed the following value in only one case in twenty:

$$r = 0.017 + 0.255 S \quad (3)$$

where:

$r$  = repeatability of the test, and

$S$  = average result, as a percentage by mass, of the values being compared.

11.1.2 *Reproducibility*—The difference between two single

and independent test results obtained by different operators working in different laboratories on identical test material, would, in the long run, in the normal and correct operation of the test method, exceed the following value in only one case in twenty:

$$R = 0.033 + 0.255 S \quad (4)$$

where:

$R$  = reproducibility of the test, and

$S$  = average result, as a percentage by mass, of the values being compared.

11.2 *Bias*—The procedure in this test method has no bias because the value of sediment can be defined only in terms of a test method.

## 12. Keywords

12.1 crude oil; extraction; fuel oil; sampling; sediment

## ANNEX

### (Mandatory Information)

#### A1. WARNING INFORMATION

##### A1.1 Toluene

A1.1.1 Keep away from heat, sparks, and open flame.

A1.1.2 Vapor harmful.

A1.1.3 Toluene is toxic.

A1.1.4 Particular care must be taken to avoid breathing the

vapor and to protect the eyes.

A1.1.5 Keep container closed.

A1.1.6 Use with adequate ventilation.

A1.1.7 Avoid prolonged or repeated contact with the skin.

*ASTM International takes no position respecting the validity of any patent rights asserted in connection with any item mentioned in this standard. Users of this standard are expressly advised that determination of the validity of any such patent rights, and the risk of infringement of such rights, are entirely their own responsibility.*

*This standard is subject to revision at any time by the responsible technical committee and must be reviewed every five years and if not revised, either reapproved or withdrawn. Your comments are invited either for revision of this standard or for additional standards and should be addressed to ASTM International Headquarters. Your comments will receive careful consideration at a meeting of the responsible technical committee, which you may attend. If you feel that your comments have not received a fair hearing you should make your views known to the ASTM Committee on Standards, at the address shown below.*

*This standard is copyrighted by ASTM International, 100 Barr Harbor Drive, PO Box C700, West Conshohocken, PA 19428-2959, United States. Individual reprints (single or multiple copies) of this standard may be obtained by contacting ASTM at the above address or at 610-832-9585 (phone), 610-832-9555 (fax), or service@astm.org (e-mail); or through the ASTM website (www.astm.org).*