



Standard Test Method for Corrosion of Cast Aluminum Alloys in Engine Coolants Under Heat-Rejecting Conditions¹

This standard is issued under the fixed designation D 4340; the number immediately following the designation indicates the year of original adoption or, in the case of revision, the year of last revision. A number in parentheses indicates the year of last reapproval. A superscript epsilon (ϵ) indicates an editorial change since the last revision or reapproval.

1. Scope

1.1 This test method covers a laboratory screening procedure for evaluating the effectiveness of engine coolants in combating corrosion of aluminum casting alloys under heat-transfer conditions that may be present in aluminum cylinder head engines.

1.2 *This standard does not purport to address all of the safety concerns, if any, associated with its use. It is the responsibility of the user of this standard to establish appropriate safety and health practices and determine the applicability of regulatory limitations prior to use.* Specific precautionary statements are given in Sections 11 and 12.

2. Referenced Documents

2.1 ASTM Standards:

D 1176 Test Method for Sampling and Preparing Aqueous Solutions of Engine Coolants or Antirusts for Testing Purposes²

3. Summary of Test Method

3.1 In this test method, a heat flux is established through a cast aluminum alloy typical of that used for engine cylinder heads while exposed to an engine coolant under a pressure of 193 kPa (28 psi). The temperature of the aluminum specimen is maintained at 135°C (275°F) and the test is continued for 1 week (168 h). The effectiveness of the coolant for preventing corrosion of the aluminum under heat-transfer conditions (hereafter referred to as heat-transfer corrosion) is evaluated on the basis of the weight change of the test specimen.

4. Significance and Use

4.1 It is essential that engine coolants prevent heat-transfer corrosion of aluminum cylinder heads during engine operation. Any corrosion products formed may deposit on interior radiator surfaces, reducing heat-transfer efficiency of the radiator. Overheating and boil-over of the cooling system may then occur.

4.2 This test method provides a means for selectively screening unused engine coolants and will readily distinguish those coolants that are unsuitable for use with aluminum cylinder head engines. However, satisfactory performance of a coolant in this test method does not ensure adequate long-term service performance. Additional, more comprehensive evaluations with simulated service, dynamometer, and vehicle tests should be used to establish the long-term effectiveness of the coolant.

5. Apparatus

5.1 *Heat-Transfer Corrosion Cell*—The assembled corrosion cell is shown schematically in Fig. 1. It is assembled from components, some of which require glass blowing or machining. The glass O-ring cell³ shall be constructed from two glass O-ring joints⁴ joined to an additional middle section of glass tubing⁵ of the same diameter to make a total length of 53 cm (21 in.). Heat-resistant O-rings⁶ shall be used. Internal pressure shall be monitored using a suitable pressure gage,⁷ and a pressure-relief valve⁸ shall be installed to protect against bursting.

5.1.1 The top assembly plate (shown in Fig. 2) shall be constructed of stainless steel, and the heat-transfer bar and bottom assembly plate (also illustrated in Fig. 2) shall preferably be constructed of stainless steel. Mild steel may be used for the heat-transfer bar and bottom assembly plate.

5.2 *Temperature Controller*,⁹ with high-temperature alarm option and temperature control range up to at least 150°C

³ A satisfactory O-ring Cell, Part #018098, ready to use, is available from HGF Scientific, 2829 North Main St., Stafford, TX 77477, (713) 499-3000.

⁴ Corning 6780, No. 40 Pyrex Brand O-ring joints have been found satisfactory. Equivalent O-ring joints with a low coefficient of expansion may be used.

⁵ Pyrex Brand Glass, a trademark of Corning Glass Works, with a standard wall thickness of 2.0 mm has been found satisfactory. Equivalent high-strength glass with a low coefficient of expansion may be used.

⁶ Viton, a trademark of E.I. duPont de Nemours and Co., Inc. has been found satisfactory. Silicone O-rings may also be satisfactory. Polytetrafluoroethylene is not suitable due to a high creep rate at the test temperature.

⁷ Ametek, U.S. Gauge Division, Model E-82 has been found satisfactory. An equivalent pressure gage may be used.

⁸ Nupro, Catalog No. SS-4CPA2-3 has been found satisfactory. An equivalent pressure relief valve may be used.

⁹ Athena, Model 2500T-B-16 F/C used with an electrical power relay or Model 2500S-B-16 F/C used with an SCR solid-state contractor has been found satisfactory. An equivalent temperature controller may be used.

¹ This test method is under the jurisdiction of ASTM Committee D15 on Engine Coolants and is the direct responsibility of Subcommittee D15.06 on Glassware Performance Tests.

Current edition approved June 10, 1996. Published September 1996. Last previous edition D 4340 – 89.

² *Annual Book of ASTM Standards*, Vol 15.05.

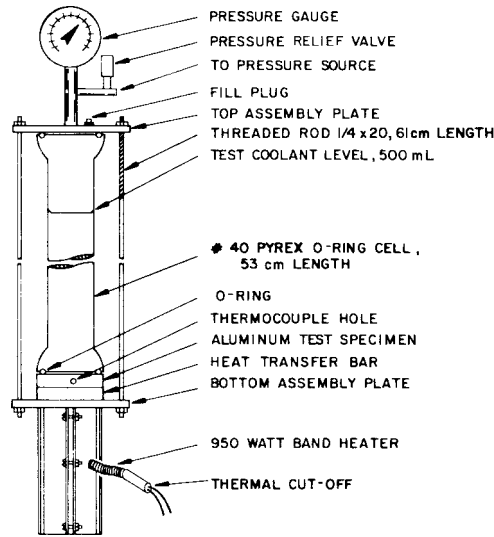
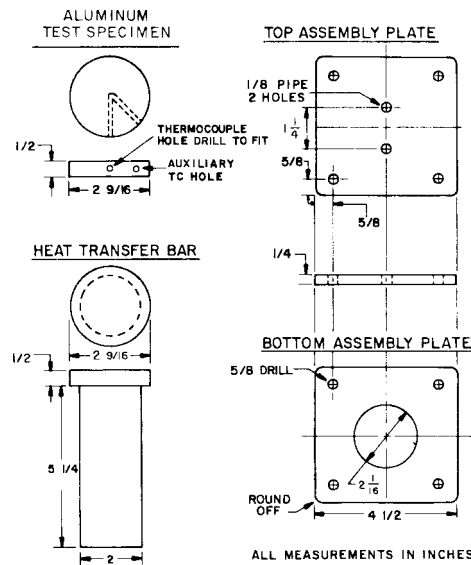

FIG. 1 Heat-Transfer Corrosion Test Assembly



Metric Equivalents

in.	1/4	1/2	5/8	1 1/4	2	2 1/16	2 9/16	4 1/2	5 1/4
mm	6.35	12.7	15.88	31.75	50.8	52.39	65.09	114.3	133.35

FIG. 2 Heat-Transfer Corrosion Test Components

(302°F). Use Type J thermocouple. A heavy-duty electrical power relay or SCR solid-state contactor is connected to the temperature controller to carry the current load to the band heaters.

5.3 *Electrical Relay*,¹⁰ 30-amp rating. The relay is changed after about every 50 000 cycles to prevent contact welding.

5.4 *Band Heaters*,¹¹ at least 950 W, 120-V ac, 5.1-cm (2-in.) inside diameter, 12.7-cm (5-in.) length.

5.5 *Ultrasonic Cleaner*,¹² about 50 W, for cleaning aluminum test samples.

5.6 *Vacuum Oven*,¹³ with temperature range up to about 150°C (302°F) for thoroughly drying cast aluminum samples.

5.7 *Vacuum Pump*,¹⁴ for use with vacuum oven.

5.8 *Thermal Cutoff*,¹⁵ for over-temperature protection, located 1.3 cm (1/2 in.) from the heat-transfer bar.

¹² Branson Model 12, 50 W, 1-qt capacity has been found satisfactory. An equivalent ultrasonic cleaner may be used.

¹³ Thelco Model 10 has been found satisfactory. An equivalent vacuum oven may be used.

¹⁴ Ace-Nelson Model 911 has been found satisfactory. An equivalent vacuum pump may be used.

¹⁵ Sylvania Model ELG 8218 has been found satisfactory. An equivalent thermal cutoff may be used.

¹⁰ Dayton 5X850A, SPST-NO-DM, 120 V, 30 amp has been found satisfactory. An equivalent mechanical, solid-state, or mercury-wetted relay may be used.

¹¹ Hotwatt, 950-W standard construction band heater, standard tightening clamp, Type L terminal has been found satisfactory. An equivalent band heater may be used.

5.9 *Compressed Air*, for pressurizing test cell.

5.10 *Clear Plastic Safety Shield*, for protection against bursting.

6. Sampling

6.1 The engine coolant concentrate shall be sampled in accordance with Test Method D 1176.

7. Metal Test Specimen

7.1 *Cast Aluminum*, conforming to UNS A03190¹⁶ is used. Specimen size is 6.5 cm (2.6 in.) in diameter, 1.3 cm (0.5 in.) thick. Fig. 2 illustrates location of the thermocouple holes.

8. Test Solution

8.1 Dissolve 165 mg of reagent grade sodium chloride in 750 mL of distilled or deionized water, and then add 250 mL of the test coolant. This is sufficient solution for two tests.

9. Test Conditions

9.1 The aluminum heat-transfer specimen temperature is maintained at $135 \pm 1^\circ\text{C}$ ($275 \pm 2^\circ\text{F}$) throughout the test by means of a thermocouple connected to the temperature controller. The thermocouple is inserted into one of the thermocouple holes in the test specimen. The other thermocouple hole is used for occasional precise temperature measurements.

9.2 The test is run continuously for 1 week (168 h).

9.3 Duplicate tests are required.

10. Preparation of Test Specimen

10.1 The following steps are necessary in the preparation of the aluminum test specimen for maximum repeatability and reproducibility:

10.2 Polish the test specimen progressively with coarse-, medium-, and fine-grit emery cloth or paper, and finally with 600-grit paper.

10.3 Wash the test specimen with warm tap water, then rinse with distilled or deionized water, and finally with acetone. Make sure thermocouple holes are free of metal chips and polishing debris. Flush the holes with acetone and remove excess liquid with a glass capillary pipet or other suitable means.

10.4 Dry the test specimen in a vacuum oven for a minimum of 4 h at 65 to 90°C (149 to 194°F) to remove residual liquid that may be retained in a porous casting. From this point, use thin cotton gloves, or equivalent, to handle the specimen to avoid weighing errors.

10.5 Remove the specimen from the oven and allow it to cool to room temperature in a desiccator.

10.6 Weigh the specimen to 0.1 mg using an analytical balance. The test sample may be reused if desired, but shall be prepared in accordance with 10.1-10.6.

11. Procedure

11.1 *Assembly*—Assemble the cell in accordance with Fig. 1. Use new O-rings between the aluminum test specimen and

glass cell for each test. To help ensure that the O-rings are properly seated, apply a small amount of the test solution to the glass O-ring groove for lubrication. Avoid overtightening of the threaded rod nuts.

11.2 *Starting the Test*—Transfer 500 mL of test coolant solution into the test cell, screw the plug in the hole, and tighten. Place the safety shield around the cell, (see **Warning**) pressurize the cell to 138 kPa (20 psi) with compressed air, and turn the band heater on. Provision must be made for a pressure rise with increase in temperature. Adjust the pressure gradually so that when the temperature reaches the proper value, the final pressure is 193 kPa (28 psi). (**Warning**—Despite the presence of a safety relief valve, test cells have burst under pressure. Use of a safety shield is absolutely necessary. A clear plastic enclosure, having allowance for adequate circulation of air yet completely surrounding the test apparatus has been successfully used for this purpose.)

11.3 *Conducting the Test*—Adjust the temperature to $135 \pm 1^\circ\text{C}$ ($275 \pm 2^\circ\text{F}$) with the temperature controller. Monitor the temperature at the auxiliary thermocouple hole at periodic intervals with a precision potentiometer. Operate the cell continuously at this temperature for 1 week (168 h).

11.4 *Terminating the Test*—At the end of the test period, turn off the heater and allow the cell to cool to room temperature before disassembly. Release pressure, remove the fill plug, and pour or siphon out the test coolant.

11.5 After disassembly, clean the cell with a large bristle brush rotated by an electric drill motor, pumice powder, detergent, and water.

12. Cleaning of Aluminum Test Specimen

12.1 Wash the specimen with a soft bristle brush using a mild detergent.¹⁷ Remove any O-ring residue by gentle scraping with a material that is softer than the aluminum (for example, a thick piece of polyethylene or polypropylene with a freshly sheared edge).

12.2 In a fume hood, immerse the specimen for exactly 10 min in an aqueous solution containing 4 parts concentrated nitric acid (70 % by weight) plus one part water at 25°C (77°F). Occasionally brush the surface with a soft bristle brush. After 10 min, transfer the beaker containing the aluminum specimen and cleaning solution to an ultrasonic cleaning unit. Apply power for 1 min. (**Warning**—Nitric acid is a strong oxidant. Avoid contact with skin, eyes, and clothing. Do not breathe vapor.)

12.3 Remove the specimen from the cleaning solution, flush well with tap water, then with distilled or deionized water, and finally with acetone. Make sure thermocouple holes are flushed well and excess liquid is removed. Inspect the surface using a microscope with a magnification range from 10 to 30×. If any deposits remain, repeat 12.2 and 12.3.

12.4 Dry the specimen in a vacuum oven using the same procedure and precautions in accordance with 10.4.

12.5 Cool the specimen to room temperature in a desiccator and weigh to the nearest 0.1 mg.

¹⁶ *Unified Numbering System for Metals and Alloys*, SAE-ASTM, Fourth Edition.

¹⁷ Alconox powder detergent has been found satisfactory. An equivalent cleaner may be used.

NOTE 1—This cleaning procedure replaces one using chromic acid, a recognized health hazard. The qualification of this cleaning method was completed by a D15.09 Task Group and is available as Research Report No. D15-1017. Copies of this report may be purchased from ASTM, 100 Barr Harbor Drive, West Conshohocken, PA. 19428-2959.

13. Determination of Blank Correction

13.1 Clean and weigh at least 3 unused specimens in accordance with 12.1-12.5.

13.2 Use the average weight loss as the blank correction, provided the deviations are not significant.

14. Calculation

14.1 Calculate the heat-transfer corrosion rate (R) as follows:

$$R = \frac{(W_b - W_a + B) \times 1000}{A} \quad (1)$$

where:

- R = corrosion rate, mg/cm²/week,
- W_b = weight of test specimen before test, g,
- W_a = weight of test specimen after test, g,
- B = weight loss of blank, g, and
- A = heat-flux surface area inside O-ring, cm².

15. Report

15.1 Report the following information:

15.1.1 Report the heat-transfer corrosion rate to the nearest 0.1 mg/cm²/week of each specimen.

15.1.2 The appearance of each specimen, such as pitting, crevice attack, color, and residual corrosion products.

15.1.3 The appearance and final pH of test coolant.

16. Precision and Bias

16.1 *Precision*—The precision of the procedure in this test method for measuring corrosion of cast aluminum alloys in engine coolants under heat-rejected conditions is being determined.

16.2 *Bias*—Since there is no accepted reference material suitable for determining the bias for the procedure in this test method, bias has not been determined.

17. Keywords

17.1 aluminum; cast aluminum alloys; cylinder head; engine coolant; heat transfer corrosion

APPENDIX

(Nonmandatory Information)

X1. INTERPRETATION OF RESULTS

X1.1 Generally, unused coolants that produce aluminum corrosion rates greater than 1.0 mg/cm²/week should be rejected, and coolants that produce less than 1.0 mg/cm²/week should be considered as candidates for further evaluation. As

indicated in 4.2, satisfactory performance of unused coolants in this test method does not ensure adequate long-term service performance, which should be established in dynamometer and field service tests.

ASTM International takes no position respecting the validity of any patent rights asserted in connection with any item mentioned in this standard. Users of this standard are expressly advised that determination of the validity of any such patent rights, and the risk of infringement of such rights, are entirely their own responsibility.

This standard is subject to revision at any time by the responsible technical committee and must be reviewed every five years and if not revised, either reapproved or withdrawn. Your comments are invited either for revision of this standard or for additional standards and should be addressed to ASTM International Headquarters. Your comments will receive careful consideration at a meeting of the responsible technical committee, which you may attend. If you feel that your comments have not received a fair hearing you should make your views known to the ASTM Committee on Standards, at the address shown below.

This standard is copyrighted by ASTM International, 100 Barr Harbor Drive, PO Box C700, West Conshohocken, PA 19428-2959, United States. Individual reprints (single or multiple copies) of this standard may be obtained by contacting ASTM at the above address or at 610-832-9585 (phone), 610-832-9555 (fax), or service@astm.org (e-mail); or through the ASTM website (www.astm.org).