



Standard Test Method for Sulfur in Petroleum Products by Hydrogenolysis and Rateometric Colorimetry¹

This standard is issued under the fixed designation D 4045; the number immediately following the designation indicates the year of original adoption or, in the case of revision, the year of last revision. A number in parentheses indicates the year of last reapproval. A superscript epsilon (ϵ) indicates an editorial change since the last revision or reapproval.

1. Scope

1.1 This test method covers the determination of sulfur in petroleum products in the range from 0.02 to 10.00 mg/kg.

1.2 The method may be extended to higher concentration by dilution.

1.3 The method is applicable to liquids whose boiling points are between 30 and 371°C (86 and 700°F). Materials that can be analyzed include naphtha, kerosine, alcohol, steam condensate, various distillates, jet fuel, benzene, and toluene.

1.4 The values in acceptable SI units are to be regarded as the standard. The values in parentheses are for information only.

1.4.1 Certain specifications for the recorder (see 5.5) are excepted.

1.5 *This standard does not purport to address all of the safety concerns, if any, associated with its use. It is the responsibility of the user of this standard to establish appropriate safety and health practices and determine the applicability of regulatory limitations prior to use.*

2. Referenced Documents

2.1 ASTM Standards:

D 1193 Specification for Reagent Water²

D 6299 Practice for Applying Statistical Quality Assurance Techniques to Evaluate Analytical Measurement System Performance³

3. Summary of Test Method

3.1 The sample is injected at a constant rate into a flowing hydrogen stream in a hydrogenolysis apparatus. The sample and hydrogen are pyrolyzed at a temperature of 1300°C, or above, to convert sulfur compounds to hydrogen sulfide (H₂S). Readout is by the rateometric detection of the colorimetric reaction of H₂S with lead acetate. Condensable components are converted to gaseous products, such as methane, during hydrogenolysis.

4. Significance and Use

4.1 In many petroleum refining processes, low levels of sulfur in feed stocks may poison expensive catalysts. This test method can be used to monitor the amount of sulfur in such petroleum fractions.

4.2 This test method may also be used as a quality-control tool for sulfur determination in finished products.

5. Apparatus^{4,5}

5.1 *Pyrolysis Furnace*—A furnace that can provide an adjustable temperature from 900 to 1400°C in a 5-mm inside diameter or larger tube is required to pyrolyze the sample. The furnace entry temperature shall allow insertion of the hypodermic tip to a depth at which the temperature is 550°C to provide sample vaporization at the injection syringe tip. This temperature shall be above the boiling point of the sample and of the sulfur compounds in the sample (see Fig. 1). The pyrolyzer tube may be of quartz; however, the lifetime is limited above 1250°C. Ceramic may be used at any temperature.

5.2 *Rateometric H₂S Readout*—Hydrogenolysis products contain H₂S in proportion to sulfur in the sample. The H₂S is measured by measuring rate of change of reflectance caused by darkening when lead sulfide is formed. Rateometric electronics, adapted to provide a first derivative output, allows sufficient sensitivity to measure below 0.1 mg/L (see Fig. 2).

5.3 *Hypodermic Syringe*—A hypodermic having a needle long enough to reach the 550°C zone is required. A side port is convenient for vacuum filling and for flushing the syringe. A 100- μ L syringe is satisfactory for injection rates down to 3 μ L/min and a 25- μ L syringe for lower rates.

NOTE 1—**Warning:** Exercise caution as hypodermics can cause accidental injury.

5.4 *Syringe Injection Drive*—The drive shall provide uniform, continuous sample injections. Variation in drive injection rate caused by mechanical irregularities of gears will cause noise. The adjustable drive shall be capable of injection from 6

¹ This test method is under the jurisdiction of ASTM Committee D-2 on Petroleum Products and Lubricants and is the direct responsibility of Subcommittee D02.03 on Elemental Analysis.

Current edition approved Jan. 10, 1999. Published March 1999. Originally published as D 4045 – 87. Last previous edition D 4045 – 96.

² *Annual Book of ASTM Standards*, Vol 11.01.

³ *Annual Book of ASTM Standards*, Vol 05.03.

⁴ The apparatus described in 5.1-5.4 inclusive is similar in specification to the equipment available from Houston Atlas, Inc., 22001 North Park Dr., Kingswood, TX 77339-3804. For further information see Drushel, H. V., "Trace Sulfur Determination Petroleum Fractions," *Analytical Chemistry*, Vol 50, 1978, p. 76.

⁵ Houston Atlas, Inc. is the sole source of supply of the apparatus known to the committee at this time. If you are aware of alternative suppliers, please provide this information to ASTM Headquarters. Your comments will receive careful consideration at a meeting of the responsible technical committee, ¹ which you may attend.

SF-111ab-2

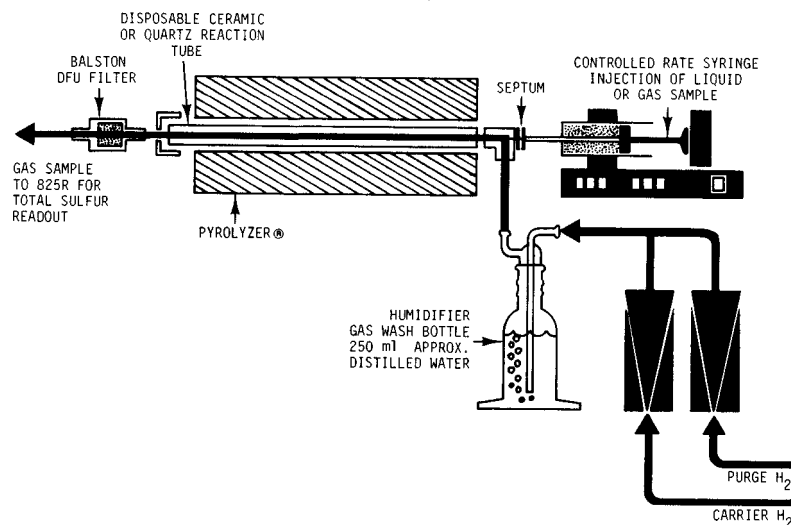

NOTE 1—The humidifier gas wash bottle is optional.

FIG. 1 Hydrogenolysis Flow Diagram

such specifications are available.⁶ Other grades may be used, provided it is first ascertained that the reagent is of sufficiently high purity to permit its use without lessening the accuracy of the determination.

6.2 *Purity of Water*—Unless otherwise indicated, references to water shall be understood to mean Type II reagent grade water conforming to Specification D 1193.

6.3 *Sensing Tape*—Lead acetate impregnated paper of chromatographic quality shall be used. (**Warning:** See Note 2.)

NOTE 2—**Warning:** Lead is a cumulative poison.

6.4 *Hydrogen*—As no commercial grade of hydrogen has a sulfur specification sufficiently low, each new source of supply must be tested. A change in the zero base line of 5 % of full scale from no flow to full flow indicates impure hydrogen. (**Warning:** See Notes 3 and 4.)

NOTE 3—**Warning:** Extremely flammable gas under pressure.

NOTE 4—**Warning:** Hydrogen is a flammable gas. Test all flow systems for leaks and purge with inert gas before introducing hydrogen and after removing hydrogen. Keep all flow systems as small in volume as practical and provide protective screening for containers other than sample flow lines. Dispose of exhaust gases in a fume hood or by vacuuming to a safe area. If gas cylinders are used handle carefully as rupture of the valve or cylinder is dangerous.

6.5 *Reference Standards:*

6.5.1 *2,2,4 Trimethyl Pentane (Isooctane)*— (**Warning:** See Note 5.)

NOTE 5—**Warning:** Extremely flammable.

6.5.1.1 ASTM Knock Test Reference Fuel⁷ may be used as the solvent. However, when this material is used, each new lot

⁶ *Reagent Chemicals, American Chemical Society Specifications*, American Chemical Society, Washington, DC. For suggestions on the testing of reagents not listed by the American Chemical Society, see *Analar Standards for Laboratory Chemicals*, BDH Ltd., Poole, Dorset, U.K., and the *United States Pharmacopeia and National Formulary*, U.S. Pharmacopeial Convention, Inc. (USPC), Rockville, MD.

⁷ Available from Phillips Petroleum Co., P.O. Drawer O, Borger, TX 79071.

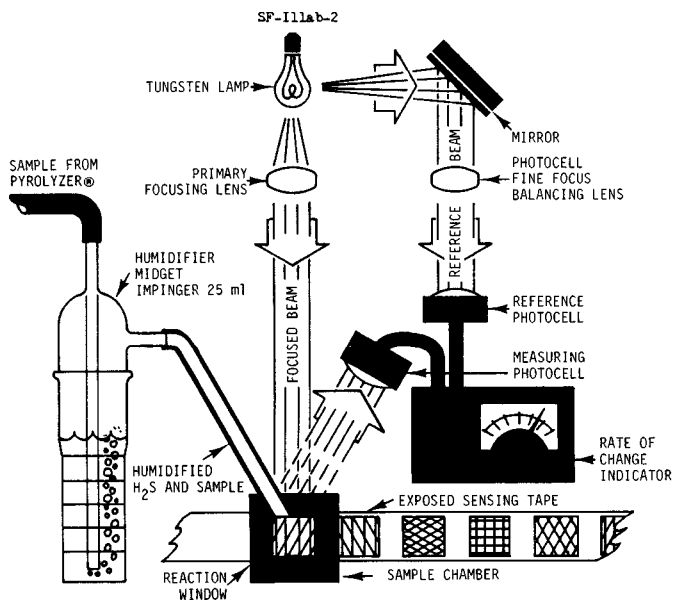

FIG. 2 Photorateometry H₂S Readout

μL/min to 0.06 μL/min over a 6-min interval.

5.5 *Recorder*—A chart recorder with 10-V full scale and 10 000-Ω input or greater and having a chart speed of 0.2 to 1 in./min (approximately 0.5 to 3 cm/min) is required. An attenuator can be used for more sensitive recorders.

5.6 *Thermocouple*—A thermocouple suitable for use at 500 to 1400°C, 250-mm long with readout is required. Type K, 1/16-in. (1.6-mm) diameter, Type 316 stainless steel sheath is suitable.

6. Reagents and Materials

6.1 *Purity of Reagents*—Reagent grade chemicals shall be used in all tests. Unless otherwise indicated, it is intended that all reagents conform to the specifications of the Committee on Analytical Reagents of the American Chemical Society where

shall be tested for sulfur by this procedure because the specifications are not rigorous enough for this application.

NOTE 6—Heptane or equivalent material may also be used but precision data is based on the use of *isooctane*.

6.6 *Acetic Acid Solution*—Mix glacial acetic acid 1 part by volume into 19 parts water (see 6.2). (**Warning:** See Note 7.)

NOTE 7—**Warning:** Corrosive.

6.7 *Di-n-Butyl Sulfide*—($\text{CH}_3\text{CH}_2\text{CH}_2\text{CH}_2$)₂S is used to prepare standards. Equivalent sulfur compound may be used if care is exercised to prevent more volatile compounds from evaporating during preparation or use of standards.

6.8 *Helium or Nitrogen Purge Gas*. (**Warning:** See Note 8.)

NOTE 8—**Warning:** Compressed gas under high pressure.

7. Preparation of Apparatus

7.1 Turn on the furnace with temperature controls at minimum. Gradually increase furnace control over a 3-h period to approximately 1300°C to minimize thermal shock. Reverse the procedure when preparing for long-term storage. For shutdown at night and over weekends, reduce temperature to about 900°C but do not turn off the furnace. Furnace and quartz tubing life are extended by not cooling to room temperature.

7.2 Connect all tubing and fill prehumidifier outside the cabinet with water if this apparatus is being used, and final humidifier inside the cabinet with 5 % by volume acetic acid solution. Purge with inert gas, then close valve. Check all connections with soap solution, and repair any leaks. Set hydrogen flow at 200 mL/min, and allow temperature to stabilize. (**Warning**—see Note 3). Make final temperature adjustment to $1315 \pm 15^\circ\text{C}$. Use a standard thermocouple to verify temperature by inserting through a septum with hydrogen flowing at the rate noted above. Determine depth of insertion required, and always insert the hypodermic tip to the 550°C point (see 7.6).

NOTE 9—**Warning:** The use of a humidifier gas wash bottle filled with approximately 250 mL of water is a potential safety hazard as hydrogen pressure may build up inside the container. The user of the test method should take appropriate safety measures to prevent an accidental injury, if the humidifier gas wash bottle is used in the analysis.

7.3 Prepare the sample injection drive. Check to be sure desired injection rate is obtained at various settings. Verify that erratic pulses of fast drive do not occur when the drive range is switched. Pulses of high sample flow above 15 $\mu\text{L}/\text{min}$ will cause carboning and spurious readings.

7.4 Install sensing tape, and turn H₂S readout analyzer on.

7.5 Connect the recorder and adjust the zero to desired position with hydrogen flowing.

7.6 Fill syringe with blank reference standard solution, typically *isooctane*, insert the needle through the septum to the 550°C temperature zone, and clamp to the syringe drive. At high temperature the hot needle may absorb sulfur and at lower temperature heavy compounds may not evaporate. Set the syringe drive rate desired, normally 6 $\mu\text{L}/\text{min}$, maximum with 200 mL/min hydrogen flow. Drive rate may be increased for increased sensitivity up to the point at which carbon is formed. (Hydrogen flow at 500 mL/min allows injection of 15 $\mu\text{L}/\text{min}$; however, dibenzothiophene conversion will be low.)

8. Calibration Standard

8.1 Prepare a reference standard-solution or solutions of strength near that expected in the unknown. Measurements can be made by weight or by volume for carrier liquid.

8.2 Units of sulfur in milligrams per litre of sample are preferred as this is independent of the density of the carrier liquid. The following equation is used to calculate the volume of solvent required to dissolve a precise weight of sulfur compound, of known composition and purity to prepare a liquid standard:

$$z = \left(\frac{b}{c} \times d \times e \times 10^6 \right) / (a) \text{ or alternatively :} \quad (1)$$

$$a = \left(\frac{b}{c} \times d \times e \times 10^6 \right) / (z) \quad (2)$$

where:

- a* = desired concentration of sulfur, mg/L, of the standard solution of *z* millilitre of volume,
- b* = molecular weight of sulfur: 32.06,
- c* = molecular weight of the sulfur compound to be used to prepare the standard.
- d* = mass of the sulfur compound used to prepare the standard, g,
- e* = purity of sulfur compound expressed as a decimal, and
- z* = millilitres of standard solution required to give the desired concentration *a*.

Example:

Calculate the volume of sulfur free *isooctane* with volume of sulfur compound necessary to dissolve 0.5013 g of 98 % by weight di-*n*-butyl sulfide to obtain a standard containing 1000 mg/L of sulfur in a solution.

$$a = 1000 \text{ mg/L}$$

$$b = 32.06$$

$$c = 146.29 \text{ di-}n\text{-butyl sulfide } (\text{CH}_3\text{CH}_2\text{CH}_2\text{CH}_2)_2\text{S}$$

$$d = 0.5013 \text{ g}$$

$$e = 0.98$$

$$z = \frac{[32.06/146.29 \times 0.5013 \times 0.98 \times 10^6]}{1000} = 107.66 \text{ mL}$$

Isooctane is added to bring the solution to a total volume of 107.66 mL. When results are to be reported in mass of parts per million mg/kg, the conversion from milligrams per litre should be done as the last step in the calculations.

8.3 To prepare a sulfur standard with a sulfur concentration of 1000 mg/L, as previously described, obtain a clean 125-mL glass container, a 100-mL flask, and a 20-mL graduated glass pipet. Rinse each thoroughly with 2,2,4-trimethyl pentane (*isooctane*). (**Warning**—see Note 5). Pour approximately 90 mL of *isooctane* into the 100-mL flask. Weigh approximately 0.5 g of di-*n*-butyl sulfide directly into the flask and record the mass added, to $\pm 50 \mu\text{g}$. Add additional *isooctane* to the flask to 100 mL. Transfer the mixture to the 125-mL container and add *isooctane* equal to the difference of *z* minus 100 mL. Keep containers closed as much as possible. Do not open containers of pure sulfur compound in the vicinity of sulfur free stocks or low-level standards. Evaporation from containers of pure sulfur compounds can contaminate other nearby liquids. This is

particularly troublesome when working below 1 mg/L near volatile sulfur compounds. Volumetrically dilute stock to prepare low-level standards.

9. Calibration and Standardization

9.1 With hydrogen flow at 200 mL/min, advance new tape and note baseline. Adjust the offset up scale about 5 % to be clear of the recorder stops. Record the stable reading average value as the zero sulfur reference and record as R_b in 11.1. There will be essentially no difference in reading with or without hydrogen flow and with or without blank injection, if blank and hydrogen have no sulfur.

9.2 Advance the tape and inject a reference material with a sulfur concentration near that expected in the unknown. After about 4 min injection time, adjust the recorder span for approximately 90 % of scale. Record the average reading as R_{std} in 10.1.

10. Procedure

10.1 Advance the tape and inject the unknown sample. After a stable reading is obtained record this average value as R_s in 11.1.

10.2 Proceed with additional samples. Every 2 h, or as needed, verify blank and span values.

10.3 To measure sulfur below 1 mg/L, inject the sample at the maximum rate, normally 6 μ L/min, that does not form carbon or gums to obtain the best signal to noise ratio. Samples above 1 mg/L require proportionally lower injection rates or span adjustment. A sharp fall in response at high sulfur levels indicates color saturation of the tape, which can be prevented by slower injection rates.

11. Calculations and Report

11.1 Calculate the concentration of the sulfur in the sample as follows:

$$S, \text{ mg/L} = C_{std} \times (R_s - R_b) / (R_{std} - R_b) \quad (3)$$

where:

- C_{std} = concentration of sulfur in the standard, mg/L,
- R_b = response for blank run using no sample or for solvent known to be sulfur-free,
- R_s = response for unknown sample, and
- R_{std} = response for standard reference material.

11.2 Report mass of parts per million of sulfur as follows:

$$S, \text{ ppm} = (\text{mg/L}) / (\text{density}) = \text{mg/kg} \quad (4)$$

since density of sample is in grams per cubic centimetres.

12. Quality Assurance/Quality Control (QA/QC)

12.1 Confirm the performance of the instrument and the test procedure by analyzing a control (QC) sample.

12.1.1 When QA/QC protocols are already established in the testing facility, these may be used when they confirm the reliability of test result.

12.1.2 When there is no QA/QC protocol established in the testing facility, Appendix X1 may be used as the QA/QC system.

12.2 Users of this test method are advised that in contractual agreements, one or more of the contracting parties can and may make Appendix X1 a mandatory practice.

13. Precision and Bias

13.1 The precision of this test method as obtained by statistical analysis of interlaboratory test results is as follows:

13.1.1 *Repeatability*—The difference between successive test results obtained by the same operator with the same apparatus under constant operating conditions on identical test material would, in the long run, in the normal and correct operation of the test method, exceed the following values only in one case in twenty (see Table 1).

$$\text{Repeatability} = 0.16 \sqrt{X} \quad (5)$$

where

X = average value of two results, mg/kg.

13.1.2 *Reproducibility*—The difference between two single and independent results obtained by different operators working in different laboratories on identical test material would, in the long run, exceed the following values only in one case in twenty (see Table 1).

$$\text{Reproducibility} = 0.26 \sqrt{X} \quad (6)$$

NOTE 10—One laboratory conducted a statistical evaluation by analyzing the same sample (with a nominal sulfur concentration of 0.2 ppm), using multiple technicians and the same instrumentation, with and without the humidifier gas wash bottle installed, and determined that results were statistically equivalent for both precision and accuracy at the 95 % confidence interval. Results of the statistical evaluation are available from ASTM Headquarters. Request RR:D02-1405.

13.2 *Bias*—The bias of this test method cannot be determined since an appropriate standard reference material containing trace sulfur levels in petroleum products is not available.

14. Keywords

14.1 ratiometric colorimetry; sulfur

TABLE 1 Repeatability and Reproducibility

Average value mg/kg of two results (x)	Repeatability, mg/kg	Reproducibility, mg/kg
0.02	0.02	0.04
0.10	0.05	0.08
0.50	0.11	0.18
1.00	0.16	0.26
2.50	0.25	0.41
10.00	0.50	0.82

APPENDIX**(Nonmandatory Information)****X1. GENERIC QUALITY CONTROL STATEMENT FOR D2 TEST METHODS**

X1.1 Confirm the performance of the instrument and the test procedure by analyzing a quality control (QC) sample.

X1.2 Prior to monitoring the measurement process, the user of the test method needs to determine the average value and control limits of the QC sample.^{8,9}

X1.3 Record the QC results and analyze by control charts or other statistically equivalent techniques to ascertain the statistical control status of the total testing process.^{7,8} Any out-of-control data should trigger investigation for root cause(s). The results of this investigation may, but not necessarily, result in instrument recalibration.

X1.4 In the absence of explicit requirements given in the test method, the frequency of QC testing is dependent on the

criticality of the quality being measured, the demonstrated stability of the testing process, and customer requirements. Generally, a QC sample should be analyzed on each day of testing routine samples. The QC frequency should be increased when a large number of samples are routinely analyzed. However, when it is demonstrated that the testing is under statistical control, the QC testing frequency may be reduced. The QC sample precision should be periodically checked against the ASTM method precision to ensure data quality.

X1.5 It is recommended that, when possible, the type of QC sample that is regularly tested be representative of the samples routinely analyzed. An ample supply of QC sample material should be available for the intended period of use and must be homogeneous and stable under the anticipated storage conditions.

X1.6 See Footnotes 8 and 9 for further guidance on QC and control charting techniques.

⁸ Practice D 6299.

⁹ ASTM MNL7: Manual of Presentation of Data Control Chart Analysis, 6th ed., Section 3: Control Chart of Individuals, available from ASTM Headquarters.

The American Society for Testing and Materials takes no position respecting the validity of any patent rights asserted in connection with any item mentioned in this standard. Users of this standard are expressly advised that determination of the validity of any such patent rights, and the risk of infringement of such rights, are entirely their own responsibility.

This standard is subject to revision at any time by the responsible technical committee and must be reviewed every five years and if not revised, either reapproved or withdrawn. Your comments are invited either for revision of this standard or for additional standards and should be addressed to ASTM Headquarters. Your comments will receive careful consideration at a meeting of the responsible technical committee, which you may attend. If you feel that your comments have not received a fair hearing you should make your views known to the ASTM Committee on Standards, 100 Barr Harbor Drive, West Conshohocken, PA 19428.