



# Standard Test Method for Hydrogen Content of Aviation Turbine Fuels by Low Resolution Nuclear Magnetic Resonance Spectrometry<sup>1</sup>

This standard is issued under the fixed designation D 3701; the number immediately following the designation indicates the year of original adoption or, in the case of revision, the year of last revision. A number in parentheses indicates the year of last reappraisal. A superscript epsilon ( $\epsilon$ ) indicates an editorial change since the last revision or reappraisal.

*This standard has been approved for use by agencies of the Department of Defense.*

## 1. Scope \*

1.1 This test method covers the determination of the hydrogen content of aviation turbine fuels.

1.2 Use Test Method D 4808 for the determination of hydrogen in other petroleum liquids.

1.3 The values stated in SI units are to be regarded as standard. The preferred units are mass percent hydrogen.

1.4 *This standard does not purport to address all of the safety concerns, if any, associated with its use. It is the responsibility of the user of this standard to establish appropriate safety and health practices and determine the applicability of regulatory limitations prior to use.* For a specific precautionary statement, see 6.1.

## 2. Referenced Documents

### 2.1 ASTM Standards:

D 1322 Test Method for Smoke Point of Kerosine and Aviation Turbine Fuel<sup>2</sup>

D 1740 Test Method for Luminometer Numbers of Aviation Turbine Fuels<sup>2</sup>

D 4057 Practice for Manual Sampling of Petroleum and Petroleum Products<sup>3</sup>

D 4808 Test Method for Hydrogen Content of Light Distillates, Middle Distillates, Gas Oils, and Residua by Low-Resolution Nuclear Magnetic Resonance Spectroscopy<sup>3</sup>

## 3. Summary of Test Method

3.1 A sample of the material is compared in a continuous wave, low-resolution, nuclear magnetic resonance spectrometer with a reference standard sample of a pure hydrocarbon. The results from the integrator on the instrument are used as a

means of comparing the theoretical hydrogen content of the standard with that of the sample, the result being expressed as the hydrogen content (percent mass basis) in the sample.

## 4. Significance and Use

4.1 The combustion quality of aviation turbine fuel has traditionally been controlled in specifications by such tests as smoke point (see Test Method D 1322), smoke volatility index, aromatic content of luminometer number (see Test Method D 1740). Evidence is accumulating that a better control of the quality may be obtained by limiting the minimum hydrogen content of the fuel.

4.2 Existing methods allow the hydrogen content to be calculated from other parameters or determined by combustion techniques. The method specified provides a quick, simple, and more precise alternative to these methods.

## 5. Apparatus

5.1 *Nuclear Magnetic Resonance Spectrometer*<sup>4</sup>—A low-resolution continuous-wave instrument capable of measuring a nuclear magnetic resonance of hydrogen atoms, and fitted with:

5.1.1 *Excitation and Detection Coil*, of suitable dimensions to contain the test cell.

5.1.2 *Electronic Unit*, to control and monitor the magnet and coil and containing:

5.1.2.1 *Circuits*, to control and adjust the radio frequency

<sup>4</sup> This method has been written around the Newport Analyzer Mark IIIF (Oxford Analytical Instruments, Ltd., Oxford, England) and the details of the method should be read in conjunction with the manufacturer's handbook.

This particular instrument was the only instrument available when the precision program was carried out. Any similar instrument would be accepted into the above method provided the new instrument was adequately correlated and proved to be statistically similar.

The Newport Analyzer Mark IIIF is no longer in production and was replaced by the manufacturer with the Newport 4000. The Newport 4000 model instrument has been demonstrated to provide equivalent results to those obtained with the Mark III models which were used to generate the precision data. As of the mid-1990's however, the Newport 4000 instrument is no longer being manufactured by the vendor. No newer models are currently being manufactured as replacements for the Newport 4000 instrument.

<sup>1</sup> This test method is under the jurisdiction of ASTM Committee D02 on Petroleum Products and Lubricants and is the direct responsibility of Subcommittee D02.03 on Elemental Analysis.

Current edition approved Nov. 10, 2001. Published December 2001. Originally published as D 3701 – 78. Last previous edition D 3701 – 99a.

<sup>2</sup> *Annual Book of ASTM Standards*, Vol 05.01.

<sup>3</sup> *Annual Book of ASTM Standards*, Vol 05.02.

\*A Summary of Changes section appears at the end of this standard.

level and audio frequency gain.

5.1.2.2 *Integrating Counter*, with variable time period in seconds.

5.2 *Conditioning Block*—A block of aluminum alloy drilled with holes of sufficient size to accommodate the test cells with the mean height of the sample being at least 20 mm below the top of the conditioning block (see Fig. 1).

5.3 *Test Cells*—Nessler-type tubes of approximately 100-mL capacity with a nominal external diameter of 34 mm and a nominal internal diameter of 31 mm marked at a distance of approximately 51 mm above the bottom of the tube by a ring around the circumference. The variation between the internal diameters of the test cells used for the sample and reference material should not be greater than  $\pm 0.5$  mm.

NOTE 1—To avoid potential difficulties with tightness when the test cell is introduced into the magnet coil, users are cautioned to avoid test cells that have nominal external diameters that are greater than 34.2 mm.

5.4 *Polytetrafluoroethylene (PTFE) Plugs for Closing Test Cells*—Plugs as shown in Fig. 1 made from pure PTFE and a tight fit in the test cells.

5.5 *Insertion Rod*—A metal rod with a threaded end as shown in Fig. 1 for inserting and removing PTFE plugs from test cells.

5.6 *Analytical Balance*—Top pan type, capable of weighing the test cells in an upright position to an accuracy of  $\pm 0.01$  g.

6. Materials

6.1 *Reference Standard*—Dodecane, 99 mass % minimum purity (**Warning**—Flammable.).

7. Sampling

7.1 Take a homogenous sample in accordance with Practice D 4057.

8. Preparation of Apparatus

8.1 Read the following instructions in conjunction with the manufacturer’s handbook. Preparation of the instrument is not critical but take care to prevent rapid temperature fluctuations of the instrument and the conditioning block, for example, avoid them from direct sunlight or from drafts.

8.2 The results obtained during the use of the equipment are susceptible to error arising from changes in the magnetic environment. Exercise care to ensure that there is a minimum of magnetic material in the immediate vicinity of the equipment and that this be kept constant throughout the course of a series of determinations.

8.3 Set the instrument controls to the following conditions:

NOTE 2—On new NMR instruments with variable gates the gate should be set at 1.5 gauss to comply with nonvariable gate instruments.

Radio frequency level	20 $\mu$ A
Audio frequency gain	500 on dial
Integration time	128 s

8.4 Switch on the main supply to the spectrometer and allow it to warm up for at least 1 h.

8.5 Place a test cell containing sample in the coil and adjust the tuning of the instrument until the two resonance curves on the oscilloscope are coincident. This setting may need to be readjusted during determinations.

8.6 Remove the test cell from the coil and observe that the signal readout is now zero  $\pm 3$  digits. This should be checked periodically during the series of tests to ensure that no contamination of the coil has occurred.

9. Preparation of Samples and Standard

9.1 Take a clean, dry test cell and PTFE plug and weigh them together to the nearest 0.01 g and record the mass. Add 30

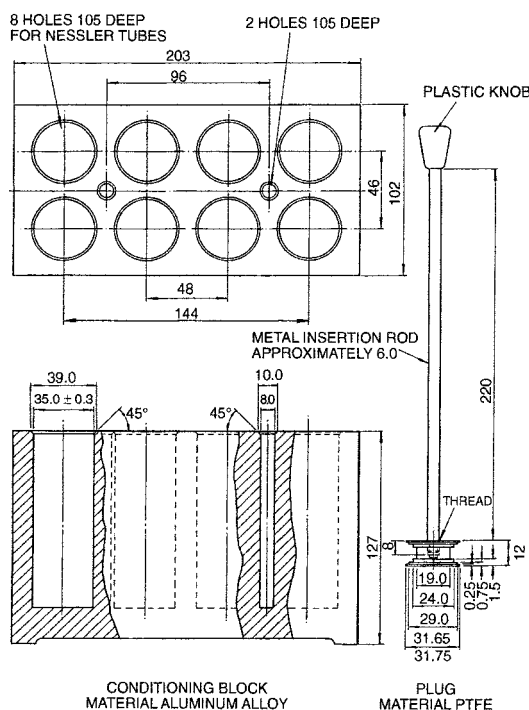

NOTE 1—All dimensions are nominal values in millimetres, unless the tolerance limit is specified..

FIG. 1 Hydrogen Content of Aviation Turbine Fuels

$\pm 1$  mL of the reference standard to the tube, taking extreme care to prevent splashing the liquid above the line inscribed on the tube. The use of a pipet is recommended for this operation.

9.2 Using the insertion rod, push the PTFE plug into the tube until it is just above the liquid-surface, keeping the tube upright. A gentle twisting of the plug as it is inserted will aid the escape of air from the test cell and normally ensure that the lip of the plug is turned up around the entire circumference. Take care to ensure that this is so, as a plug that is not properly inserted will allow rapid sample evaporation and give rise to change in the results obtained.

NOTE 3—The insertion of the PTFE plug can be facilitated by inserting a length of thin (less than 0.2 mm diameter) copper wire down the inside surface of the disc until it is approximately 38 mm from the graduation mark and then pushing the PTFE plug down past the wire which is then removed.

9.3 The bottom rim of the plug should be at or slightly below the 51-mm mark on the test cell. Unscrew the insertion rod carefully without disturbing the plug.

9.4 Place the reference standard in the sample conditioning block.

9.5 Repeat the procedure outlined in 9.1-9.4 using the material to be tested.

## 10. Procedure

10.1 Leave the sample and reference standard in the conditioning block for at least 0.5 h to ensure they reach uniform temperature, that is room temperature, before measurements are made.

10.2 Read the following instructions in conjunction with the procedure provided in the manufacturer's handbook for analyzing samples. Specific steps may vary with instrument manufacturer and model. In cases where the manufacturer's instructions differ from the following steps, follow the manufacturer's instructions.

10.3 Take the reference standard and place it carefully in the coil. When fully entered the top of the test cell should be just above the cover of the spectrometer unit.

10.4 Check that the peaks on the oscilloscope are coincident and if this is not so, adjust the tuning until they are.

10.5 When the reference standard has been in the magnet unit for at least 3 s, push the reset button.

NOTE 4—It is important that a delay of this magnitude be allowed before commencing measurement in order that the hydrogen nuclei are fully polarized in the magnetic field.

10.6 After a count time of 128 s the digital display will stop at its final value. Record the integrator counts and push the reset button again and record the second reading.

10.7 Weigh the cell and contents and record the total mass.

10.8 Replace the reference standard in the conditioning block and make similar duplicate readings on the sample to be tested.

NOTE 5—Measurements will be altered by temperature variations in the sample and reference standard so these must be returned to the conditioning block when measurements are not being made.

NOTE 6—The determined hydrogen content will be affected by any instrument drift, slight variations in temperature between the sample and reference standard and loss of sample or reference standard, or both, due to evaporation. Therefore when a series of results are to be determined, sample and reference standard should be measured, weighed and calculated as pairs. When the mass change of the reference standard is greater than 0.01 g between consecutive weighings, the cause of this should be investigated and corrected. Losses are usually due to poor fitting of the PTFE plug while gains will probably be due to contamination of the coil.

## 11. Calculation

11.1 For each sample and reference standard, subtract the mass of the test cell and PTFE plug from the total mass of the test cell determined in 10.7.

$$\text{Hydrogen content, mass \%} = \frac{S_T}{S_R} \times \frac{M_R}{M_T} \times 15.39 \quad (1)$$

where:

- $S_T$  = mean of integrator counts on sample under test,
- $S_R$  = mean of integrator counts on reference standard,
- $M_R$  = mass of reference sample, and
- $M_T$  = mass of sample under test

## 12. Report

12.1 Report the mass percent hydrogen content to the nearest 0.01 mass %.

## 13. Precision and Bias <sup>5</sup>

13.1 The precision of the method as obtained by statistical examination of interlaboratory test results is as follows:

13.1.1 *Repeatability*—The difference between successive test results obtained by the same operator with the same apparatus under constant operating conditions on identical test material would, in the long run, in the normal and correct operation of the test method exceed the following value only in one case in twenty:

$$0.09 \text{ mass \%} \quad (2)$$

13.1.2 *Reproducibility*—The difference between two single and independent results obtained by different operators working in different laboratories on identical test material would, in the long run, in the normal and correct operation of the test method exceed the following value only in one case in twenty:

$$0.11 \text{ mass \%} \quad (3)$$

13.2 *Bias*—A 1977 research report indicated that the hydrogen content determined by this test method is biased high with respect to the expected value for pure known materials.

## 14. Keywords

14.1 aviation turbine fuel; hydrogen; nuclear magnetic resonance

<sup>5</sup> Supporting data are available and on loan from ASTM International Headquarters. Request RR: D02-1186.

**SUMMARY OF CHANGES**

Sub-Committee D02.03 has identified the location of selected changes to this standard since the last issue (D 3701 – 99a) that may impact the use of this standard.

- (1) Updated information in Footnote 4 to reflect that the Newport 4000 instrument is no longer being manufactured currently for use in the test. similar to instructions already in the method in Section 8 (Preparation of Apparatus) that refers the user to the manufacturer's handbook.
- (2) Inserted a new paragraph 10.2 to instruct the user to follow the instructions from the vendor in the Procedure section,

*ASTM International takes no position respecting the validity of any patent rights asserted in connection with any item mentioned in this standard. Users of this standard are expressly advised that determination of the validity of any such patent rights, and the risk of infringement of such rights, are entirely their own responsibility.*

*This standard is subject to revision at any time by the responsible technical committee and must be reviewed every five years and if not revised, either reapproved or withdrawn. Your comments are invited either for revision of this standard or for additional standards and should be addressed to ASTM International Headquarters. Your comments will receive careful consideration at a meeting of the responsible technical committee, which you may attend. If you feel that your comments have not received a fair hearing you should make your views known to the ASTM Committee on Standards, at the address shown below.*

*This standard is copyrighted by ASTM International, 100 Barr Harbor Drive, PO Box C700, West Conshohocken, PA 19428-2959, United States. Individual reprints (single or multiple copies) of this standard may be obtained by contacting ASTM at the above address or at 610-832-9585 (phone), 610-832-9555 (fax), or [service@astm.org](mailto:service@astm.org) (e-mail); or through the ASTM website ([www.astm.org](http://www.astm.org)).*