



Standard Test Method for Life Performance of Automotive Wheel Bearing Grease¹

This standard is issued under the fixed designation D 3527; the number immediately following the designation indicates the year of original adoption or, in the case of revision, the year of last revision. A number in parentheses indicates the year of last reappraisal. A superscript epsilon (ϵ) indicates an editorial change since the last revision or reappraisal.

1. Scope

1.1 This test method covers a laboratory procedure for evaluating the high-temperature life performance of wheel bearing greases when tested under prescribed conditions.

NOTE 1—Changes to this test method in the 1985 revision increased test severity. Results will not be comparable with data from earlier procedures.

1.2 The values stated in SI units, except apparatus dimensions, are to be regarded as the standard. Apparatus dimensions in inches are to be regarded as the standard.

1.3 *This standard does not purport to address all of the safety concerns, if any, associated with its use. It is the responsibility of the user of this standard to establish appropriate safety and health practices and determine the applicability of regulatory limitations prior to use.* For specific hazard statements, see 8.1-8.4.

2. Referenced Documents

- 2.1 *AFBMA Standard:*
AFBMA Standard 19, 1974 (ANSI B. 3.19-1975)²

3. Terminology

3.1 Definitions:

3.1.1 *lubricant, n*—any material interposed between two surfaces that reduces the friction or wear between them.

3.1.2 *lubricating grease, n*—a semi-fluid to solid product of a dispersion of a thickener in a liquid lubricant.

3.1.2.1 *Discussion*—The dispersion of the thickener forms a two-phase system and immobilizes the liquid lubricant by surface tension and other physical forces. Other ingredients are commonly included to impart special properties.

3.1.3 *thickener, n*—in *lubricating grease*, a substance composed of finely-divided particles dispersed in a liquid lubricant to form the product's structure.

3.1.3.1 *Discussion*—The solid thickener can be fibers (such as various metallic soaps) or plates or spheres (such as certain

non-soap thickeners) which are insoluble or, at the most, only very slightly soluble in the liquid lubricant. The general requirements are that the solid particles be extremely small, uniformly dispersed, and capable of forming a relatively stable, gel-like structure with the liquid lubricant.

3.2 Definitions of Terms Specific to This Standard:

3.2.1 *automotive wheel bearing grease, n*—a lubricating grease specifically formulated to lubricate automotive wheel bearings at relatively high grease temperatures and bearing speeds.

3.2.2 *grease life, n*—of *wheel bearing grease*, amount of time operated under prescribed conditions of load, speed, and temperature until preset torque limit is exceeded.

3.2.2.1 *Discussion*—The *off-time*, which is part of the 20 h and 4 h off-cycle, is not recorded and is not included as part of grease life.

4. Summary of Test Method

4.1 The test grease is distributed in the bearings of a modified, automobile front wheel hub-spindle-bearings assembly. While the bearings are thrust-loaded to 111 N, the hub is rotated at 1000 rpm and the spindle temperature maintained at 160°C for 20 h, 4 h off operating cycle. The test is terminated when grease deterioration causes the drive motor torque to exceed a calculated motor cut off value. Grease life is expressed as the accumulated on-cycle hours.

5. Significance and Use

5.1 This test method differentiates among wheel bearing greases having distinctly different high-temperature characteristics. It is not the equivalent of long-time service tests, nor is it intended to distinguish between the products having similar high-temperature performance properties.

5.2 This test method has proven to be helpful in screening greases with respect to life performance for automotive wheel bearing applications.

¹ This test method is under the jurisdiction of ASTM Committee D02 on Petroleum Products and Lubricants and is the direct responsibility of Subcommittee D02.G0 on Lubricating Grease.

Current edition approved Nov. 10, 2002. Published February 2003. Originally approved in 1976. Last previous edition approved in 1995 as D 3527-95.

² Available from American National Standards Institute (ANSI), 25 W. 43rd St., 4th Floor, New York, NY 10036.

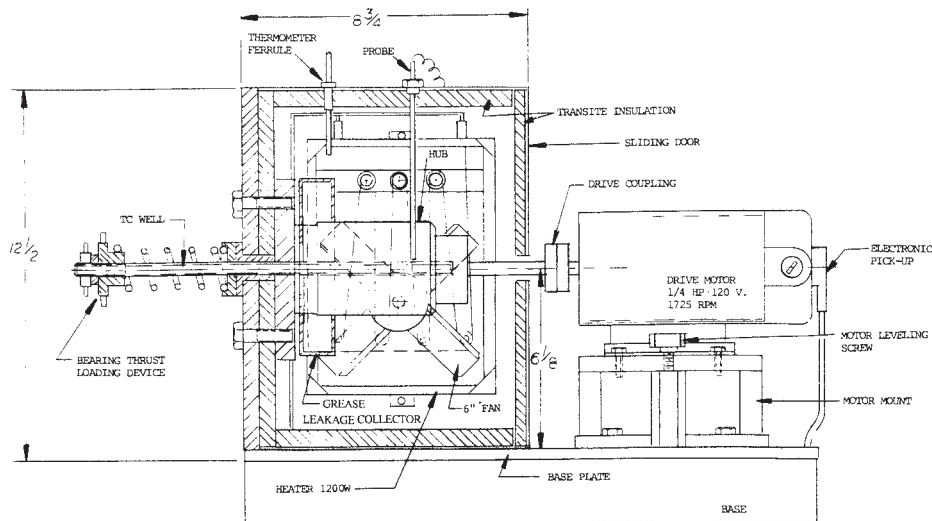

NOTE—Caution should be taken when modifying older units since some may still contain asbestos insulation leading to a possible inhalation hazard.

FIG. 1 Wheel Bearing Lubricant Tester (Elevation View)

6. Apparatus

6.1 *Test Assembly*³ (see Fig. 1 and Fig. 2).

6.1.1 *Custom-made Wheel Hub-Spindle-Bearing Assembly* (Fig. 3).

6.1.2 *Oven*, electrically heated by 1800 watt heater, thermostatically controlled to maintain spindle temperature at $160 \pm 1.5^\circ\text{C}$.

6.1.3 *Spindle Drive Motor*, 1/4 hp, 120 volts dc with 1725 rpm speed control the hub; motor torque is indicated by a meter equipped with an adjustable, automatic cut-off.

6.1.4 *Fan Drive Motor*, 1/30 hp, 120 v dc, 1550 rpm.

6.2 Motor speed, oven temperature, spindle temperature, time cycles and torque are controlled or monitored, or both, by accessory equipment.

6.3 *Balance* having a minimum capacity of 100 g and minimum sensitivity of 0.1 g.

7. Test Bearings

7.1 Use LM67048-LM67010 and LM11949-LM11910 (AFBMA Standard 19) inboard and outboard bearings⁴ respectively.

8. Reagents and Materials

8.1 *n-Heptane*—reagent grade minimum purity (**Warning**—Flammable. Harmful if inhaled.)

8.2 *Isopropyl Alcohol* —reagent grade minimum purity (**Warning**—Flammable.)

8.3 *Penetone*⁵—ECS (**Warning**—Combustible. Vapors can be harmful.)

8.4 *Stoddard Solvent or Mineral Spirits*—reagent grade (**Warning**—Combustible. Vapors may be harmful.)

8.5 *SAE 10W Engine Oil*.

8.6 *00 Grade Steel Wool*.

9. Preparation of Bearings

9.1 Carefully remove new bearings (cups and cones) from their packages and place in a suitable clean container. Wash with *n*-Heptane to remove all rust preventative.

9.2 Repeat washing with *n*-Heptane two additional times to be certain all rust preventative has been removed. Use a clean beaker each time.

9.3 Drain *n*-Heptane from the bearings and set them on a clean, lint-free cloth or towel to air dry.

NOTE 2—Cleaning may be facilitated by the use of a sonic cleaner.

10. Procedure

10.1 Prior to each test, check the freedom of movement of the thrust loading shaft (Fig. 3) in the spindle. If binding is noted, remove and clean both shaft and spindle bore.

10.2 Install the new cups in the cleaned hub in the location shown in Figs. 1 and 2.

10.3 Weigh an inboard and outboard bearing cone to the nearest 0.1 g. Fill the cones with test grease using an extra set of cups and the grease packer shown in Figs. 4 and 5. Use care to avoid moving the rollers or bearing components while removing the cones from the cups and in all subsequent wiping and handling steps. Strike off excess grease flush with the front

³ The sole source of supply of the test assembly known to the committee at this time is Koehler Instrument Co., Inc., 1595 Sycamore Ave., Bohemia, Long Island, NY 11716. If you are aware of alternative suppliers, please provide this information to ASTM International Headquarters. Your comments will receive careful consideration at a meeting of the responsible technical committee,¹ which you may attend.

⁴ Timken or Bower bearings are suitable.

⁵ The sole source of supply of Penetone known to the committee at this time is Penetone Corp., 74 Hudson Ave., Tenafly, NJ 07670. If you are aware of alternative suppliers, please provide this information to ASTM International Headquarters. Your comments will receive careful consideration at a meeting of the responsible technical committee,¹ which you may attend.

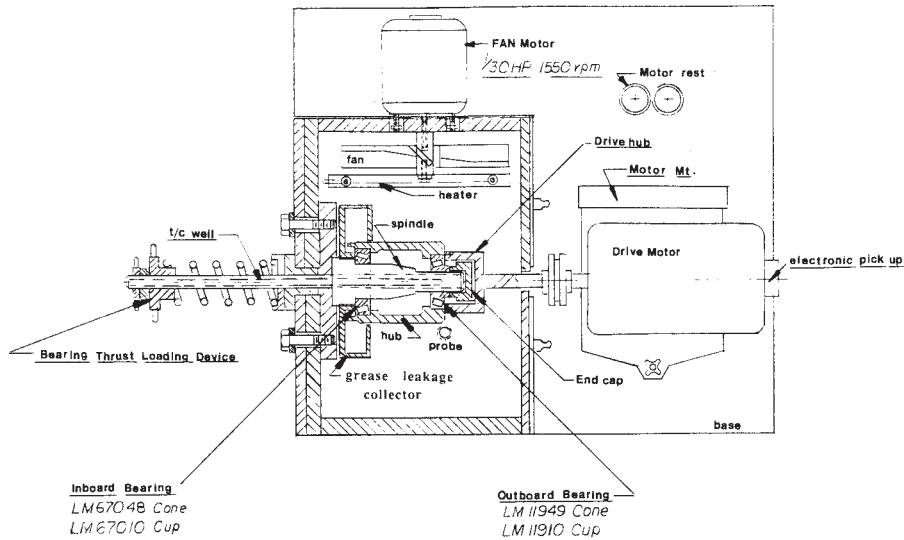

FIG. 2 Wheel Bearing Lubricant Tester (Top View)

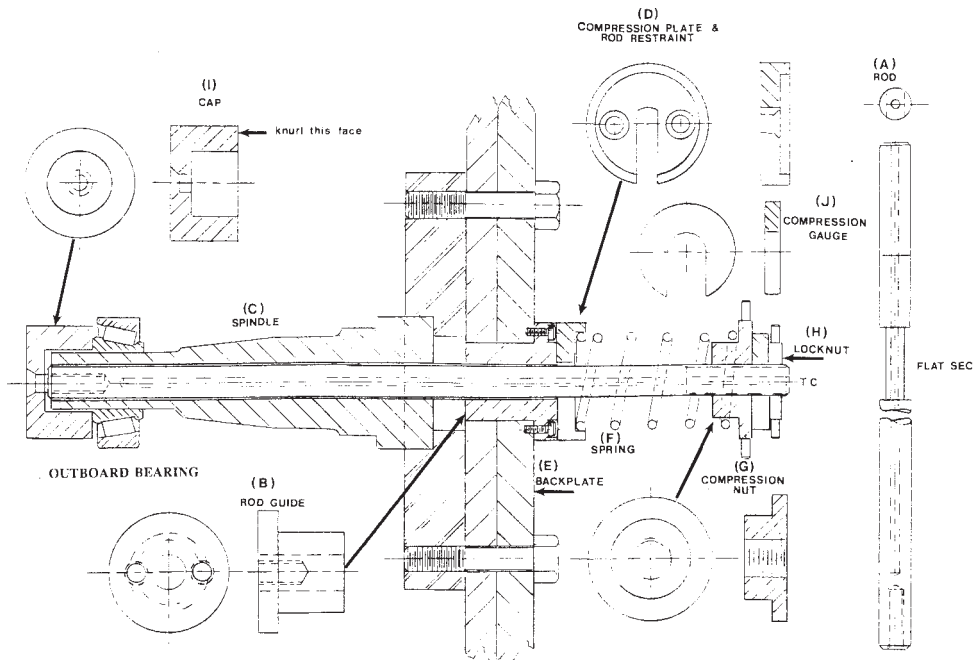

FIG. 3 Spindle and Thrust Rod Components

face of the cone (near small end of rollers) using a small spatula. Wipe all grease from cone bore, cone back face, exterior cage surfaces, and exposed roller surfaces with a clean, lint-free cloth or towel and reweigh. Adjust the grease weight in the inboard cone to 3.0 ± 0.1 g and in the outboard cone to 2.0 ± 0.1 g by wiping or adding grease to the groove between the cage and the cone back face. Apply a thin film of grease on the cups.

10.4 Install the leakage collector, inboard cone, hub, and outboard cone on the spindle (Fig. 2). Lock the components in place with the end cap and screw. Install the spindle connector.

10.5 Referring to Fig. 3, adjust the thrust load as follows: tighten the compression nut *G* until the spring *F* is seated against the back plate *E*, but not compressed. Bring the lock nut *H* up to the compression nut *G*. Without moving *H*, compress

F by tightening *G* until the compression gage *J* will fit between *H* and *G*. Hold *J* in position and back off *G* until *J* is held firmly between *H* and *G*.

NOTE 3—Compression gage *J* has been machined such that insertion and adjustment of *G* causes spring *F* to compress and apply a 111-N (25-lbf) axial load on the wheel bearings.

10.6 Insert the thermocouple in the spindle thrust rod and position the junction at the center of the outboard bearing position. Close the cabinet and position the motor to operating location. (**Warning**—Do not engage the drive at this point. Start the motor and adjust the speed to 1000 ± 50 rpm. At this point observe and record the unloaded motor current *N*.)

10.7 Turn off the motor, engage the drive coupling and lock in position. Set the timer to begin a 20-h cycle. Restart the

$$C = 8(T - N) + N \quad (1)$$

where:

- C = motor cut-off value, amps,
- T = steady-state current, amps, and
- N = unloaded motor current, amps.

Set the automatic torque cutoff of motor to value of C.

10.9 Permit the apparatus to operate under the prescribed conditions of load, speed, and temperature until the preset torque limit is exceeded at which point the test will be terminated automatically. Record the time the unit shuts down.

NOTE 4—The motor is protected by a 30 s time delay.

10.10 Allow the tester to cool to a safe handling temperature and disassemble. If the tester is disassembled hot, use insulated gloves.

11. Parts Cleanup

11.1 With a suitable spatula, remove as much grease as possible from the grease collector, end cap, and spindle connector.

11.2 Place the parts in a suitable clean container (preferably stainless steel) and cover with Penetone ECS (**Warning**—See 8.3). Install a loosely fitting cover and heat gently ($70 \pm 10^\circ\text{C}$) until the parts are clean (several hours). Avoid prolonged (overnight) heating as parts corrosion can occur.

11.3 Remove the parts from the solvent and wash with hot running water. Rinse immediately with isopropyl alcohol (**Warning**—See 8.2). Air dry. If the parts will not be used immediately, apply a film of SAE 10W engine oil.

11.4 Use a suitable spatula to scrape grease off of the spindle. Remove the remaining deposits from the spindle using 00 grade steel wool and Stoddard solvent (**Warning**—See 8.4). If strongly adherent deposits resist this treatment, remove the spindle and clean in hot Penetone ECS.

12. Report

12.1 Report the hours to failure.

13. Precision and Bias ⁶

13.1 The precision of this test method was determined by statistical examination of interlaboratory results. Research Report D02-1007⁷ procedures were followed in the round-robin testing and statistical analysis of data. In 1988 a more precise description of the bearing packing procedure was included in 10.3. The precision data shown in Table X2.1 was obtained earlier using a less detailed packing procedure.

13.1.1 *Repeatability*—The difference between two test results obtained by the same operator with the same apparatus under constant operating conditions on identical test material would, in the long run, in the normal and correct operation of the test method, exceed the following values in only one case in twenty:

$$\text{Repeatability} = (0.8)X \quad (2)$$

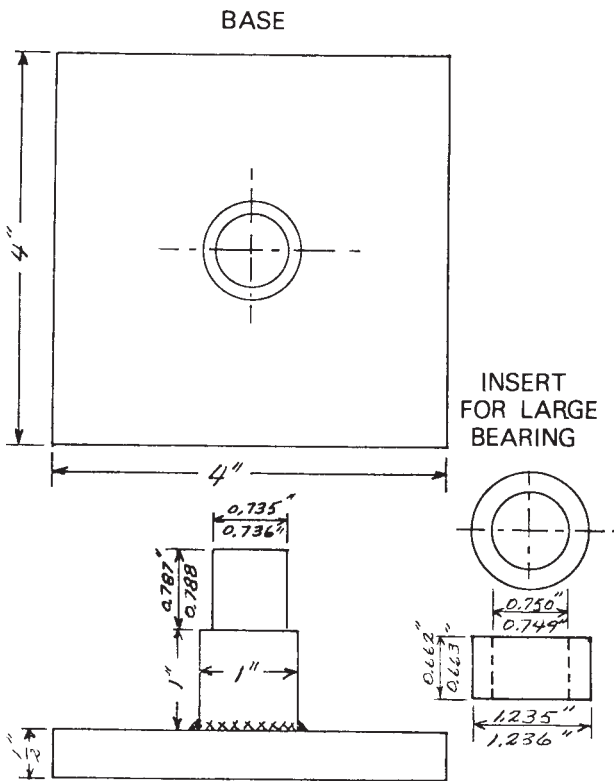

MATL: STAINLESS STEEL
FIG. 4 Bearing Packer

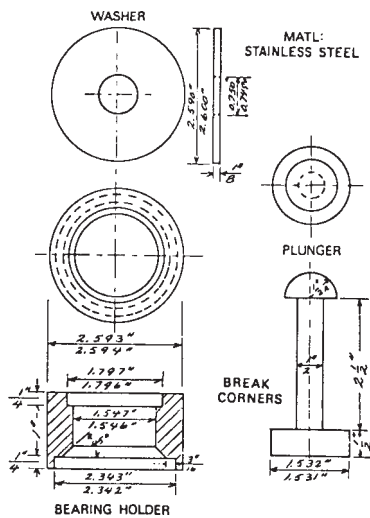

FIG. 5 Bearing Packer

motor and again adjust the speed to 1000 ± 50 rpm. Turn on the heaters and adjust the oven temperature to maintain the spindle temperature at $160 \pm 1.5^\circ\text{C}$ ($320 \pm 2.7^\circ\text{F}$). When the spindle temperature has stabilized at the test temperature, make no further adjustment of the oven temperature for the duration of the test.

10.8 A steady-state running torque will develop in the first 2 h of operation as indicated by a stabilized value on the meter. Record this value as steady-state current *T*. Determine the motor cutoff value as follows:

⁶ Supporting data have been filed at ASTM International Headquarters and may be obtained by requesting Research Report RR: D02-1177.

⁷ Supporting data have been filed at ASTM International Headquarters and may be obtained by requesting Research Report RR: D02-1007.

where:

X = the average of the two test results.

13.1.2 *Reproducibility*—The difference between two single and independent results obtained by different operators working in different laboratories on identical test material would, in the long run, in the normal and correct operation of the test method, exceed the following values in only one case in twenty:

$$\text{Reproducibility} = (1.2)X \quad (3)$$

where:

X = the average of the two test results.

13.2 *Bias*—The procedure in this test method has no bias because the value of grease life can be defined only in terms of the test method.

NOTE 5—A round robin of twelve cooperators testing five greases has resulted in the precision statement shown above. The data are shown in Table X2.1. In this round robin, determinations were made using testers by PAM, Koehler, and Falex. No distinction was made as all testers gave equivalent results.

14. Keywords

14.1 automotive wheel bearing grease; grease life performance; lubricating grease

APPENDIXES

(Nonmandatory Information)

X1. METRIC EQUIVALENTS

X1.1 See Table X1.1.

TABLE X1.1 Metric Equivalents for Figs. 1, 4, and 5

in.	mm	in.	mm
1/8	3.175	1.546	39.268
1/4	6.350	1.547	39.294
1/2	12.700	1.796	45.618
0.661	16.789	1.797	45.644
0.662	16.815	2.342	59.487
0.735	18.669	2.343	59.512
0.736	18.694	2 1/2	63.500
0.749	19.025	2.590	65.786
0.75	19.050	2.6	66.040
0.787	19.990	2.594	65.888
1.00	25.400	4.0	101.600
1.235	31.369	6.0	152.400
1.236	31.394	6 1/8	155.570
1.531	38.887	8 3/4	222.250
1.532	38.913	12 1/2	317.500

X2. WHEEL BEARING LIFE TEST (HOURS)

X2.1 See Table X2.1.

TABLE X2.1 Wheel Bearing Life Test (Hours)

G827	G828	G829	G830	G831	Laboratory
80	230	160	20	100	1 ^A
60	220	180	40	80	
60	320.5	344.5	39.9	80.2	2 ^B
60.1	419.8	360	60	160	
98.8	278	298	40	65	3 ^C
74	160	179	40	20	
93	160	– 99.99	80	120	6 ^B
89	140	– 99.99	40	180	
100	220	326	60	180	6 ^A – 1
100	240	404	80	140	
154	205	360	40	160	6 ^A – 2
100	220	977	60	180	
75	427	426	82	124	7 ^A
61	326	749	41	224	
163.4	187.7	443	61.3	121.5	8 ^A
164.4	184.6	551	58.9	101.6	
80.7	179.4	454.4	71.6	117	8 ^B
97.4	159.4	241.4	64.5	122	
267	193	379	92	184	9 ^A
280	200	350	102	175	
99.6	310	619.3	60.3	80.7	10 ^A
99.9	280	463.5	60.3	160.5	
100	280	280	40	60	11 ^B
120	180	240	80	100	

^A Koehler.

^B PAM.

^C Falex.

ASTM International takes no position respecting the validity of any patent rights asserted in connection with any item mentioned in this standard. Users of this standard are expressly advised that determination of the validity of any such patent rights, and the risk of infringement of such rights, are entirely their own responsibility.

This standard is subject to revision at any time by the responsible technical committee and must be reviewed every five years and if not revised, either reapproved or withdrawn. Your comments are invited either for revision of this standard or for additional standards and should be addressed to ASTM International Headquarters. Your comments will receive careful consideration at a meeting of the responsible technical committee, which you may attend. If you feel that your comments have not received a fair hearing you should make your views known to the ASTM Committee on Standards, at the address shown below.

This standard is copyrighted by ASTM International, 100 Barr Harbor Drive, PO Box C700, West Conshohocken, PA 19428-2959, United States. Individual reprints (single or multiple copies) of this standard may be obtained by contacting ASTM at the above address or at 610-832-9585 (phone), 610-832-9555 (fax), or service@astm.org (e-mail); or through the ASTM website (www.astm.org).