



Standard Test Methods for Flash Point of Liquids by Small Scale Closed-Cup Apparatus¹

This standard is issued under the fixed designation D 3278; the number immediately following the designation indicates the year of original adoption or, in the case of revision, the year of last revision. A number in parentheses indicates the year of last reapproval. A superscript epsilon (ϵ) indicates an editorial change since the last revision or reapproval.

This standard has been approved for use by agencies of the Department of Defense.

^{ε1} NOTE— Figures A1.1 and Figures A1.2 were corrected editorially in October 1997.

1. Scope

1.1 These test methods cover procedures for determining whether a material does or does not flash at a specified temperature or for determining the lowest finite temperature at which a material does flash when using a small scale closed-cup apparatus.² The test methods are applicable to paints, enamels, lacquers, varnishes, and related products having a flash point between 0 and 110°C (32 and 230°F) and viscosity lower than 150 St at 25°C (77°F).

NOTE 1—Tests at higher or lower temperatures are possible.

NOTE 2—More viscous materials may be tested in accordance with Annex A4.

NOTE 3—Organic peroxides may be tested in accordance with Annex , which describes the applicable safety precautions.

NOTE 4—The U.S. Department of Labor (OSHA, Hazard Communications), the U.S. Department of Transportation (RSPA), and the U.S. Environmental Protection Agency (EPA) have specified Test Methods D 3278 as one of several acceptable methods for the determination of flash point of liquids in their regulations.

NOTE 5—These test methods are similar to International Standards ISO 3679 and ISO 3680.

1.2 *This standard should be used to measure and describe the response of materials, products, or assemblies to heat and flame under controlled conditions and should not be used to describe or appraise the fire-hazard or fire-risk of materials, products, or assemblies under actual fire conditions. However, results of the test may be used as elements of a firehazard or a fire-risk assessment which takes into account all of the factors which are pertinent to an assessment of the fire hazard or fire risk of a particular end use.*

1.3 *This standard does not purport to address all of the safety concerns, if any, associated with its use. It is the responsibility of the user of this standard to establish appropriate safety and health practices and determine the applicability of regulatory limitations prior to use.* For specific hazard

statements, see Note 7 and Note 12.

2. Referenced Documents

2.1 ASTM Standards:

D 56 Test Method for Flash Point by Tag Closed Tester³

D 93 Test Methods for Flash Point by Pensky-Martens Closed Tester³

D 850 Test Method for Distillation of Industrial Aromatic Hydrocarbons and Related Materials⁴

D 1015 Test Method for Freezing Points of High-Purity Hydrocarbons³

D 1078 Test Method for Distillation Range of Volatile Organic Liquids⁴

2.2 ISO Standards:⁵

ISO 3679 Paints, varnishes, petroleum and related products—Determination of flash point—Rapid equilibrium method

ISO 3680 Paints, varnishes, petroleum and related products—Flash/no flash test—Rapid equilibrium method

3. Terminology

3.1 Definitions:

3.1.1 *flash point*—the lowest temperature, corrected to a pressure of 760 mm Hg (101.3 kPa, 1013 mbar), at which application of an ignition source causes the vapor of the specimen to ignite under specified conditions of test.

4. Summary of Test Methods

4.1 By means of a syringe, 2 mL of the sample is introduced through a leakproof entry port into the tightly closed small scale closed-cup apparatus² or directly into the cup that has been brought to the required test temperature. As a flash/no flash test, the expected flash point temperature may be a specification or other operating requirement. After 1 min, a test flame is applied inside the cup and note is taken whether or not the test specimen flashes. A fresh specimen must be used if a repeat test is necessary.

¹ These test methods are under the jurisdiction of ASTM Committee D-1 on Paint and Related Coatings, Materials, and Applications and are the direct responsibility of Subcommittee D01.22 on Health and Safety.

Current edition approved Jan. 10, 1996. Published April 1996. Originally published as D 3278 – 73. Last previous edition D 3278 – 95.

² Small scale closed-cup apparatus has been found suitable for this purpose.

³ *Annual Book of ASTM Standards*, Vol 05.01.

⁴ *Annual Book of ASTM Standards*, Vol 06.04.

⁵ Available from American National Standards Institute, 13th Floor, 11 W. 42nd St., New York, NY 10036.

4.2 For a finite flash point measurement, the temperature is sequentially increased through the anticipated range, the test flame being applied at 5°C (9°F) intervals until a flash is observed. A true determination is then made using a fresh specimen, starting the test at the temperature of the last interval before the flash point of the material and making tests at increasing 0.5°C (1°F) intervals.

5. Significance and Use

5.1 Flash point is one of the properties used to define the flammability of a liquid. It is used to classify liquids according to their flammability by governmental regulatory agencies. It may also be used to determine the presence of impurities or contaminants in a given liquid, such as the presence of residual solvents in solvent-refined drying oils. See Test Methods D 56 and D 93 for alternate flash point testing.

6. Apparatus

6.1 *Test Cup and Cover Assembly*⁶—The essential dimensions and requirements of the apparatus are shown in Fig. A1.1 and described in Annex A1.

6.2 *Thermometers*,⁷ low, medium, high temperature small scale. Test to determine that the scale error does not exceed 0.25°C (0.5°F). The use of a magnifying lens assists in making temperature observations.

6.3 *Glass Syringe*, 2 ± 0.1-mL capacity at 25°C (77°F), to provide a means of taking a uniform specimen. Check the capacity by discharging water into a weighing bottle and weighing. Adjust plunger if necessary. A disposable syringe of equal precision may be used.

6.4 *Aluminum Cooling Block*⁸ (describing in Annex A2), that fits snugly within the test cup used for rapid cooling of the sample cup.

6.5 *Barometer*.

7. Reagents and Materials

7.1 *p-Xylene*,⁹ reference standard.

7.2 *n-Butanol*,¹⁰ reference standard.

7.3 *Cooling Mixtures* of ice and water or solid CO₂ (dry ice) and acetone.

7.4 *Liquified Petroleum Gas*.

7.5 *Heat Transfer Paste*.¹¹

8. Sampling

8.1 The specimen size for each test is 2 mL. Obtain at least a 25-mL sample from the bulk source and store in a nearly full,

tightly closed, clean glass container or in other container suitable for the type of liquid being sampled.

NOTE 6—**Caution:** Erroneously high flash points may be obtained if precautions are not taken to avoid loss of volatile material. Do not open sample containers unnecessarily and do not transfer the specimen to the cup unless the temperature of the specimen is at least 20°F (10°C) below the expected flash point. Discard samples in leaky containers.

NOTE 7—**Precaution:** Do not store samples in plastic bottles (polyethylene, polypropylene, etc.), as volatile material may diffuse through the walls.

9. Preparation of Apparatus

9.1 Prior to initial use or after removal of the thermometer, insert the thermometer into its pocket (see Fig. A1.1) with a good heat transfer paste.

9.2 To help in making the necessary settings during a test, before the initial use determine the relationship between the temperature control dial and thermometer readings at intervals not over 9°F (5°C) throughout the scale range of the heater.

9.3 Place the tester in a subdued light and in a position not exposed to disturbing drafts. Provide a black-coated shield, if necessary.

9.4 Read the manufacturer's operating and maintenance instructions on the care and servicing of the tester. Observe the specific suggestions regarding the operation of the various controls.

9.5 Check the accuracy of the tester by duplicate determination of the flash point of the *p*-xylene reference standard (Annex A3). The mean of the results should be 81 ± 1.5°F (27.2 ± 0.8°C). An additional reference standard, *n*-butanol (Annex A3), may be used to check the accuracy at approximately the temperature specified by U.S. regulatory agencies in defining flammable liquids. The mean of duplicates should be 36.7 ± 0.8°C (98 ± 1.5°F). If not, remove the thermometer and observe whether sufficient heat transfer paste surrounds the thermometer to provide good heat transfer from the cup to the thermometer.

TEST METHOD A—FLASH/NO FLASH

10. Procedure—Ambient to 110°C (230°F)

10.1 Inspect the inside of the test cup, lid, and shutter mechanism for cleanliness and freedom from contamination. Use an absorbent tissue to wipe clean, if necessary. Lock the cover lid tightly in place.

10.2 Switch the heater on, if not already at stand-by. To rapidly approach the specification flash temperature of the material under test, turn the heater dial fully clockwise (Note 8) causing the heater signal (red) light to glow. When the thermometer indicates a temperature of about 3°C (5°F) below the specification or target flash-point temperature, reduce the heat input to the test cup by slowly turning the heater control dial counter clockwise until the signal light goes out (Note 9).

NOTE 8—When a desired temperature is dialed on the controller, the elapsed time to reach this temperature may be greater than if the controller is turned “full on,” but less attention is required.

NOTE 9—The test cup temperature is stable when the signal light slowly cycles on and off.

10.3 Determine the barometric pressure to determine the

⁶ Closed-cup flash point testers and their accessories meeting the requirements of the unit shown in Fig. A1.1 are available from ERDCO Engineering Corp., 721 Custer Ave., Evanston, IL 60202 or Stanhope-Seta Ltd., Park Close Englefield Green, Engham, Surrey, TW20 OXD, England.

⁷ Thermometers may be obtained from the suppliers of the Small Scale Tester.

⁸ Cooling blocks may be obtained from ERDCO Engineering Corp.

⁹ *p*-Xylene is available as “Flash Point Check Fluid” from Special Products Div., Chemical Dept., Phillips Petroleum Co., Borger, TX 25303.

¹⁰ *n*-Butanol may be obtained from chemical supply companies.

¹¹ Heat transfer paste is available from the suppliers of the Small Scale Tester. No. 340 Silicone is available from Dow Corning Corp., 2030 Willard H. Dow Center, Midland, MI 48674. G641 Heat Transfer Compound is available from General Electric Co., Products Div., 12 Corporate Woods Blvd., Albany, NY 12211.

corrected specification temperature at that barometric pressure (see 15.1).

10.4 After the test-cup temperature has stabilized at the specification or target flash point, charge the syringe with the sample being tested and insert the tip of the syringe into the filling orifice (Fig. A1.2)Fig. A2.1, taking care not to lose any material. Discharge the specimen into the test cup by completely depressing the syringe plunger, then remove the syringe. If the material has a viscosity greater than 45 SUS at 38°C (100°F) or equivalent of 9.5 cSt at 25°C (77°F), raise the lid and discharge the contents of the syringe directly into the cup. Immediately close the lid tightly.

10.5 Set the 1-min timing device. In the meantime, open the gas control valve and light the pilot and test flames. Adjust the test flame size with the pinch valve to match the size of the 5/32-in. (4-mm) diameter flame gage.

10.6 After 1 min has elapsed, observe the temperature. If at the specification temperature (accounting for the differences of the barometer reading from 760 mm), apply the test flame by slowly and uniformly opening the slide fully and closing completely over a period of approximately 2½ s (Note 10), watching for a flash (Note 11) while the flame is inserted.

NOTE 10—When inserted, the nozzle of the ignition device should intersect the plane of the underside of the cover (see A1.1).

NOTE 11—The material is considered to have flashed only if a comparatively large blue flame appears and propagates itself over the surface of the liquid. Occasionally, particularly near the actual flash-point temperature, application of the test flame may give rise to a halo; this effect should be ignored.

10.7 Turn off the test and pilot flame. Clean the apparatus in preparation for the next test.

11. Procedure—0°C (32°F) to Ambient

11.1 If the specification or target flash point is at or below ambient temperature, cool the sample to 5 to 10°C (10 to 20°F) below that point by some convenient means.

11.2 Cool the tester to approximately the temperature of the sample by inserting the cooling block (Fig. A2.1) filled with a cooling mixture (Note 12 and Note 13) into the sample well. Dry the cup with a paper tissue to remove any collected moisture prior to adding the specimen using a precooled syringe.

NOTE 12—**Precaution:** Be careful in handling the cooling mixture and cooling block; wear gloves and goggles. Mixtures such as dry ice and acetone can produce severe frost bite.

NOTE 13—**Caution:** Be careful when inserting the cooling block into the tester cup to prevent damage to the cup.

11.3 Introduce the specimen as in 10.4. Allow the temperature to rise under ambient conditions or increase the temperature of the cup by rotating the heater controller clockwise slowly until the specification temperature adjusted for barometric pressure is reached. Determine whether the material flashes as in 10.5 and 10.6.

11.4 Turn off the test and pilot flames. Clean the apparatus.

TEST METHOD B—FINITE FLASH POINT

12. Procedure—Ambient to 110°C (230°F)

12.1 *Preliminary or Trial Test:*

12.1.1 Follow steps 10.1-10.5, omitting the barometric reading and using an estimated finite flash point instead of specification flash-point temperature.

12.1.2 After 1 min has elapsed, observe the temperature. Apply the test flame by slowly and uniformly opening the slide fully and closing completely over a period of 2½s (Note 10), watching for a flash (Note 11) while the flame is inserted.

12.2 If a flash is observed, proceed as in 12.3. If no flash is observed, proceed as in 12.4.

12.3 Using a temperature 5°C (9°F) lower than the temperature observed in 12.1.2, repeat 12.1 (Note 4). If a flash is still observed, repeat at 5°C lower intervals until no flash is observed.

NOTE 14—Never make a repeat test on the same specimen. Always take a fresh portion for each test.

12.3.1 After establishing the approximate flash point, repeat 12.1 with a new specimen, but stabilizing the test temperature at which no flash occurred previously. Observe if a flash occurs at this temperature. If not, increase the temperature by making a small adjustment to the temperature controller so that an increase of 0.5°C (1°F) occurs within 1 min. Test for a flash at each 0.5°C interval, recording the temperature at which the flash actually occurs. Record the barometric pressure. Clean the tester.

12.3.1.1 Repeat 12.3.1 with a new specimen. Calculate the corrected mean temperature in accordance with 15.2. Turn off pilot and test flames and clean the tester.

12.4 Using a test temperature 5°C (9°F) higher than the temperature observed in 12.2, repeat 12.1 (Note 14). If no flash is observed, repeat at 5°C higher intervals until a flash is observed.

12.4.1 After establishing the approximate flash point (12.4) with new specimens, make two determinations of the flash point in accordance with 12.3.1 and calculate the corrected mean temperature in accordance with 15.2.

13. Procedure—0°C (32°F) to Ambient Temperature

13.1 *Preliminary or Trial Test:*

13.1.1 Cool the sample to 3 to 5°C (5 to 10°F) below the expected flash point.

13.1.2 Cool the tester to approximately the temperature of the sample by inserting the cooling block filled with a cooling medium into the sample well. (**Precaution**—See Note 12 and Note 13.)

13.1.3 Introduce the specimen using a precooled syringe as in 10.4. Set the 1-min timing device. After 1 min observe the temperature, then apply the test flame by slowly and uniformly opening the slide fully and closing completely over a period of 2½ s, watching for a flash (Note 11) while the flame is inserted. Record the temperature.

13.2 If a flash is observed, proceed as in 13.3. If no flash is observed, proceed as in 13.4.

13.3 Take a new specimen and recool the sample cup to 5°C (9°F) below the previous temperature (13.1.3). After 1 min, check for a flash as in 13.1.3. If the material flashes, repeat at 5°C lower intervals until no flash is observed.

13.3.1 After establishing the approximate flash point, repeat 13.1.1 and 13.1.3 with a new specimen but stabilizing the test

temperature at which no flash occurred previously. Observe if a flash occurs at this temperature. If not, increase the temperature by making a small adjustment to the temperature controller so that an increase of 0.5° C (1°F) occurs within 1 min. Test for a flash at each 0.5°C interval, recording the temperature at which the flash actually occurs. Record the barometric pressure.

13.3.1.1 Repeat 13.3.1 with a new specimen. Calculate the corrected mean in accordance with 15.2. Turn off pilot and test flames and clean the tester.

13.4 Using a test temperature 5°C (9°F) higher than the temperature observed in 13.1.3, repeat 13.1.3 (Note 14). If no flash is observed, repeat at 5°C higher intervals until a flash is observed.

13.4.1 After establishing the approximate flash point (13.4), make the determinations of the flash point in accordance with 13.3 and calculate the corrected mean in accordance with 15.2.

14. Clean-up of Apparatus and Preparation for Next Test

14.1 Unlock the lid assembly of the tester and raise to the hinge stop. Soak up liquid with an absorbent paper tissue and wipe dry. Clean the underside of the lid and filling orifice. A pipe cleaner may be of assistance in cleaning the orifice.

14.2 If the material is a viscous liquid or contains dispersed solids, after soaking up most of the specimen add a small amount of a solvent suitable for the sample to the cup. Then soak up the solvent and wipe clean the interior surfaces of the cup with an absorbent tissue paper.

NOTE 15—If necessary to remove residual high boiling solvent residues, moisten tissue with acetone and wipe dry.

NOTE 16—If any further cleaning is necessary, remove the lid and shutter assembly. Disconnect the silicone rubber hose and slide the lid assembly to the right to remove. If warm, handle carefully.

14.3 After the cup has been cleaned, its temperature may be rapidly increased to some stand-by value by turning the temperature control dial to an appropriate point.

NOTE 17—It is convenient to hold the test cup at some stand-by temperature (depending on planned usage) to conserve time in bringing the cup within the test temperature range. The cup temperature may be quickly lowered by inserting the aluminum cooling block filled with an appropriate cooling mixture into the cup.

14.4 The syringe is easily cleaned by filling it several times with acetone or other compatible solvent, discharging the solvent each time, and allowing the syringe to air dry with the plunger removed. Replace the plunger, and pump several times to displace any solvent vapor with air.

15. Correction for Barometric Pressure

15.1 Determine the corrected specification flash point to be used in Test Method A by the following equations:

$$F = S - 0.06 (760 - P)$$

$$C = T - 0.03 (760 - P)$$

$$F = S - 0.42 (101.3 - B)$$

$$C = T - 0.23 (101.3 - B)$$

where:

$F C$ = flash point to be observed to obtain the specification flash point at standard pressure, °C (°F),

$S(T)$ = specification flash point, °C (°F), and

$P(B)$ = ambient barometric pressure, mm Hg (kPa).

NOTE 18—The barometric pressure used in this calculation must be the ambient pressure for the laboratory at the time of test. Many aneroid barometers, such as those used at weather stations and airports, are precorrected to give sea-level readings. These must not be used.

15.2 When the barometric pressure in Test Method B differs from 760 mm Hg, correct the flash point temperature, A , by means of the following equations:

$$A = F + 0.06 (760 - P)$$

$$= C + 0.03 (760 - P)$$

$$= F + 0.42 (101.3 - B)$$

$$= C + 0.23 (101.3 - B)$$

where:

$F(C)$ = observed flash point, °C (°F), and

$P(B)$ = ambient barometric pressure, mm Hg (kPa).

16. Report

16.1 When using the flash/no flash method, report whether or not the sample flashed at the required flash point and that Test Method A was used.

16.2 If an actual flash point was determined, report the mean of duplicate determinations to the nearest 0.5°C (1°F), provided the difference between the values does not exceed 1°C (2°F) and that Test Method B was used.

17. Precision and Bias ¹²

17.1 No statement is made about either the precision or bias of Test Method A-Flash/No Flash, since the result merely states whether there is conformance to the criteria for success specified in the procedure.

17.2 On the basis of an interlaboratory study of Test Method B in which one operator in each of five laboratories made two determinations on two different days on four solvents, three resins and two paints of different flash points, the intralaboratory and interlaboratory standard deviations were found to be:

Materials	Standard Deviation	
	Within-Laboratory	Between-Laboratory
Solvents (viscosity below 45 SUS at 20°C (100°F)), °F	0.98	1.55
Resins and Paints (viscosity above 45 SUS at 20°C (100°F)), °F	1.89	2.41

Based on these standard deviations, the following criteria should be used for judging the acceptability of results at the 95 % confidence level:

17.3 *Liquids at or Below 45 SUS at 20°C (100°F) or Equivalent Viscosity:*

17.3.1 *Repeatability*—Two results, each the mean of two determinations, obtained by the same operator on different

¹² Supporting data are available from ASTM Headquarters. Request RR:D01-1000. These data are also reported in the *Journal of Paint Technology*, Vol 45, No. 581, p. 44.

days should be considered suspect if they differ by more than 1.7°C (3°F).

17.3.2 *Reproducibility*—Two results, each the mean of two measurements, obtained by different laboratories, should be considered suspect if they differ by more than 3.3°C (6°F).

17.4 *Viscous Liquid Above 45 SUS at 20°C (100°F) or Liquids With Dispersed Solids:*

17.4.1 *Repeatability*—Two results, each the mean of two determinations, obtained by the same operator on different days should be considered suspect if they differ by more than 3.3°C (6°F).

17.4.2 *Reproducibility*—Two results, each the mean of two measurements, obtained by different laboratories should be considered suspect if they differ by more than 5°C (9°F).

17.5 A study to determine the precision for materials with a viscosity greater than 150 St has not been made.

17.6 The precision for liquid peroxides has not been determined, but the precision of liquid peroxides should be similar to that of other liquids.

17.7 *Bias*—No estimate of the bias of flash-point tests can be determined as no absolute values are available. In addition, the results are equipment and method dependent.

18. Keywords

18.1 flash/no flash; flash point; organic peroxides; organic solvents; small scale closed-cup apparatus

ANNEXES

(Mandatory Information)

A1. APPARATUS SPECIFICATIONS

A1.1 A typical apparatus is shown in Fig. A1.1. Electrical heaters are fastened to the cup in a way as to provide for efficient transfer of heat. The tester includes a variable heater control device with a scaled dial and a visible signal to indicate when energy is or is not being applied. Energy may be supplied from a 100 to 250 V 50/60 Hz (for stationary use) or by a 12-V d-c battery service (for field use). An adjustable test flame and a pilot flame to maintain the test flame are provided. These flames may be fueled by piped gas service (fixed location) or by a self-contained tank of liquefied petroleum gas (7.4) (for

portability). A test flame measuring $\frac{5}{32}$ in. (4 mm) in diameter may be checked against a gage ring on the surface of the tester. Never recharge the gas tank with the pilot or test flames lighted, nor in the vicinity of other naked flames. A 1-min audible signal is a desirable accessory. The cover is fitted with an opening slide device capable of inserting the ignition flame into the well when the slide is open. When inserted the nozzle of the ignition device shall intersect the plane of the underside of the cover.

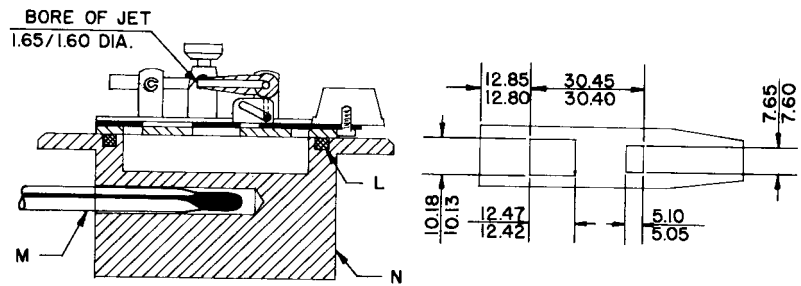
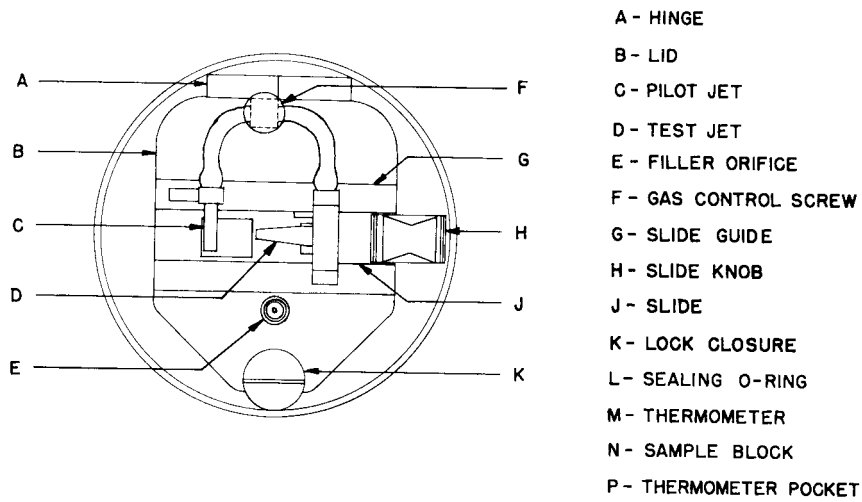

SLIDE (1.22 THICK APPROX.)

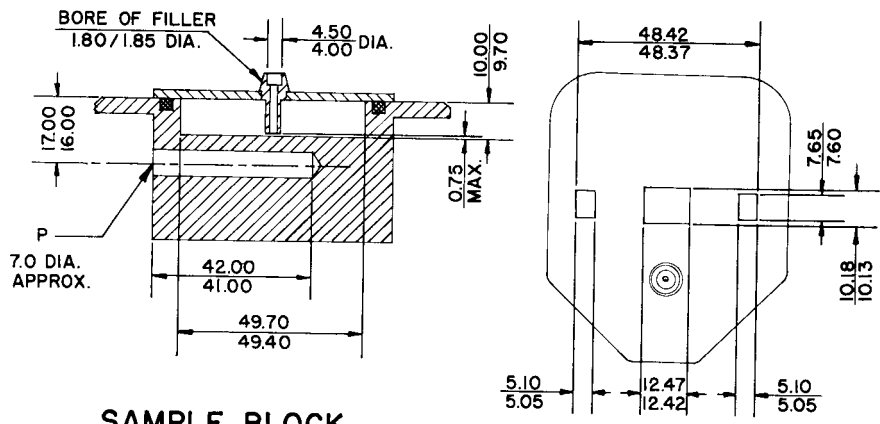

SAMPLE BLOCK

LID (2.00 THICK APPROX.)

NOTE 1—All dimensions are in millimetres.

FIG. A1.1 Small Scale Closed Cup Unit

A2. COOLING BLOCK

A2.1 The cooling block with dimensions as shown in Fig. A2.1 is made of aluminum and covered with pipe insulation.

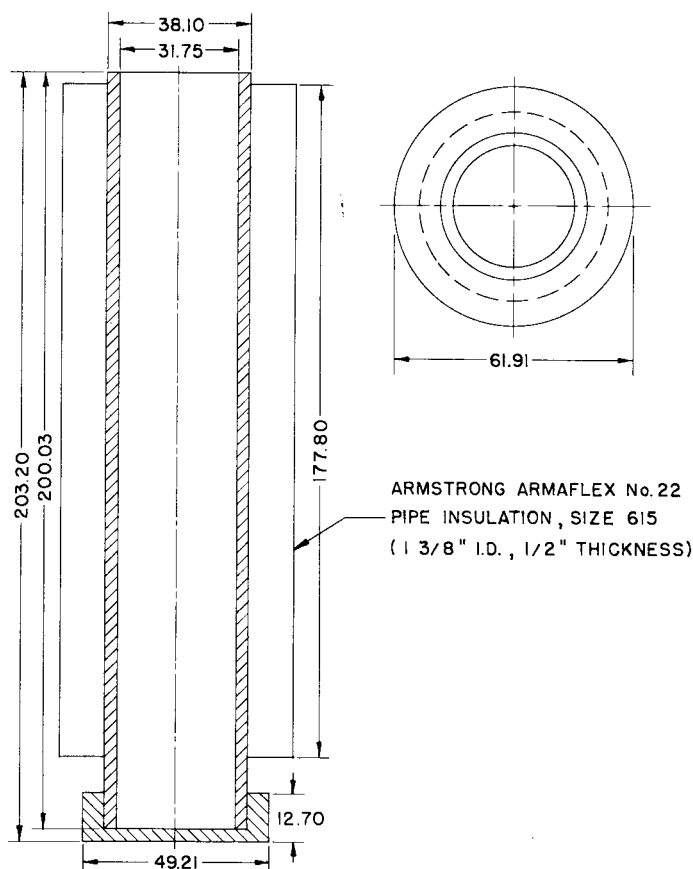

FIG. A2.1 Cooling Block

A3. SPECIFICATIONS FOR *p*-XYLENE AND *n*-BUTANOL REFERENCE STANDARDS

A3.1 *p*-Xylene

A3.1.1 *Specific Gravity, 15.56/15.56°C (60/60°F) Range*—0.860 minimum, 0.866 maximum.

A3.1.2 *Boiling Range*—2°C maximum from start to dry point when tested in accordance with Test Method D 850 or Test Method D 1078. The range shall include the boiling point of pure *p*-xylene, which is 138.35°C.

A3.1.3 *Freezing Point*—11.23°C minimum (95 % molal purity) as determined in accordance with Test Method D 1015.

A3.2 *n*-Butanol

A3.2.1 *Specific Gravity, 20/4°C Range*—0.809 minimum, 0.810 maximum.

A3.2.2 *Boiling Range*—1.5°C maximum from start to dry time determined in accordance with Test Method D 1078. The range shall include the boiling point of pure *n*-butanol, which is 117.7°C.

A3.2.3 *Melting Point Range*—90°C minimum, -89.5°C maximum.

A3.2.4 *Refractive Index $n_{20/D}$ Range*—1.3985 minimum, 1.3993 maximum.

A3.2.5 *Purity by Gas Chromatography*—99.5 % minimum.

A4. TESTING HIGH VISCOSITY LIQUIDS

A4.1 High-viscosity materials may be added to the cup by the following procedure:

A4.1.1 *Procedure*—Back load a 5 or 10-mL syringe with the sample to be tested and extrude 4 mL into the cup. Spread the specimen as evenly as possible over the bottom of the cup.

A4.1.2 If the sample cannot be loaded into a syringe and extruded, use other means of adding the specimen to the cup

provided a presentative 4-mL specimen can be put into the cup. A spoon of appropriate size is convenient. Push the material from the spoon into the cup.

A4.1.3 If the test specimen does not seal off the bottom of the filling orifice, seal the orifice from the top by suitable means.

A4.2 Using Test Method A (Section 10 or 11), determine

whether or not the material flashes or, using Test Method B (Section 12 or 13), determine the flash point of the specimen.

A5. TESTING ORGANIC PEROXIDES

A5.1 Organic peroxides may be tested by Test Methods A or B with minor modifications that take into account the hazard potential of these compounds.

A5.1.1 The tester should be located behind a transparent safety shield, and fire resistant gloves should be worn.

A5.1.2 The procedure in 10.1 is followed with the exception that the cover lid is not locked in place. Rather, a spring-wire test-tube holder is clamped to the hold-down lock on the lid to

provide an extension arm about 5 in. (12.7 cm) long. A weight of approximately 100 g is hung from the end of the test tube holder. This arrangement adequately seals the test while allowing venting with a rapidly decomposing peroxide.

A5.1.3 Follow the procedures described in Test Methods A or B (Sections 10-14). However, when applying the test flame, grasp the handle by means of a second test tube holder, pliers, or tongs.

The American Society for Testing and Materials takes no position respecting the validity of any patent rights asserted in connection with any item mentioned in this standard. Users of this standard are expressly advised that determination of the validity of any such patent rights, and the risk of infringement of such rights, are entirely their own responsibility.

This standard is subject to revision at any time by the responsible technical committee and must be reviewed every five years and if not revised, either reapproved or withdrawn. Your comments are invited either for revision of this standard or for additional standards and should be addressed to ASTM Headquarters. Your comments will receive careful consideration at a meeting of the responsible technical committee, which you may attend. If you feel that your comments have not received a fair hearing you should make your views known to the ASTM Committee on Standards, 100 Barr Harbor Drive, West Conshohocken, PA 19428.