



Standard Test Method for Pumpability of Industrial Fuel Oils¹

This standard is issued under the fixed designation D 3245; the number immediately following the designation indicates the year of original adoption or, in the case of revision, the year of last revision. A number in parentheses indicates the year of last reapproval. A superscript epsilon (ϵ) indicates an editorial change since the last revision or reapproval.

1. Scope *

1.1 This test method is intended for use on petroleum fuel oils, such as those covered in Specification D 396 Grade No 4(Light), 4, 5(Light), 5, and 6, or similar fuels.

1.2 The values stated in SI units are to be regarded as standard. The values in parentheses are for information only.

1.3 *This standard does not purport to address all of the safety concerns, if any, associated with its use. It is the responsibility of the user of this standard to establish appropriate safety and health practices and determine the applicability of regulatory limitations prior to use.*

2. Referenced Documents

2.1 *ASTM Standards:*

D 396 Specification for Fuel Oils²

D 445 Test Method for Kinematic Viscosity of Transparent and Opaque Liquids (and the Calculation of Dynamic Viscosity)²

E 1 Specification for ASTM Thermometers³

3. Terminology

3.1 *Definitions:*

3.1.1 *handling point*—an indication of the minimum temperature to which an oil should be heated in any part of the suction or delivery line of an oil-handling installation when the installation is operating. If the storage tank does not contain an outflow heater, this temperature is necessarily the minimum oil storage temperature.

3.1.2 It is defined as that temperature at which the oil has an apparent viscosity of 0.6 Pa·s (6 P), at a rate of shear of 9.7 s^{-1} , when cooled and tested under prescribed conditions.

3.1.3 *storage point*—an indication of the minimum temperature to which an oil should be heated in any part of an oil-handling installation when starting up after a shutdown. It is also an indication of the minimum temperature at which the oil should be stored in a tank fitted with an outflow heater.

3.1.4 It is defined as that temperature at which the oil has an apparent viscosity of 2.5 Pa·s (25 P), at a rate of shear of 9.7 s^{-1} , when cooled and tested under prescribed conditions.

4. Summary of Test Method

4.1 A sample of the oil, preheated if necessary to a specified temperature to make it fluid, is poured into the cup of the portable viscometer. This is immersed in a bath at a predetermined temperature. After 15 min, the viscometer is started at a rate of shear of 9.7 s^{-1} . After a further 5 min, the bath is cooled at $0.5^\circ\text{C}/\text{min}$ ($1^\circ\text{F}/\text{min}$). The temperatures at which apparent viscosities of 0.6 Pa·s (6 P) and 2.5 Pa·s (25 P) are obtained are determined.

5. Significance and Use

5.1 This test method is designed to give an indication of the minimum storage and minimum handling temperatures which may be used for a given fuel oil. This test method is cited in Specification D 396.

6. Apparatus

6.1 *Temperature Measuring Device*—conforming to specifications for ASTM thermometers 63C, 64C, and 12C, or equivalent, in accordance with Specification E 1, or any other temperature measuring device with equal or better accuracy and equal temperature response.

6.2 *Oil Container*, made of aluminum or aluminum alloy to the dimensions given in Fig. 1A and B. The cup (Fig. 1A) is a loose fit on the Model VW outer cylinder of the viscometer. The inner diameter of the cup shall not exceed the outside diameter of the viscometer outer cylinder by more than 0.4 mm or less than 0.15 mm. The cup has four grooves in the side to allow easy flow of oil past the outer viscometer cylinder; these align with four recesses in the cap (Fig. 1B) when in position. The cap supports the viscometer cup to which it is secured by a bayonet fitting.

¹ This test method is under the jurisdiction of ASTM Committee D02 on Petroleum Products and Lubricants and is the direct responsibility of Subcommittee D02.07 on Flow Properties.

Current edition approved March 10, 2003. Published May 2003. Originally approved in 1973. Last previous edition approved in 1996 as D 3245–96.

This test method is based on IP 230 but contains a precision statement based on an ASTM/IP round robin using waxy and non-waxy fuel oils typical of those marketed in North America.

² *Annual Book of ASTM Standards*, Vol 05.01.

³ *Annual Book of ASTM Standards*, Vol 14.03.

*A Summary of Changes section appears at the end of this standard.

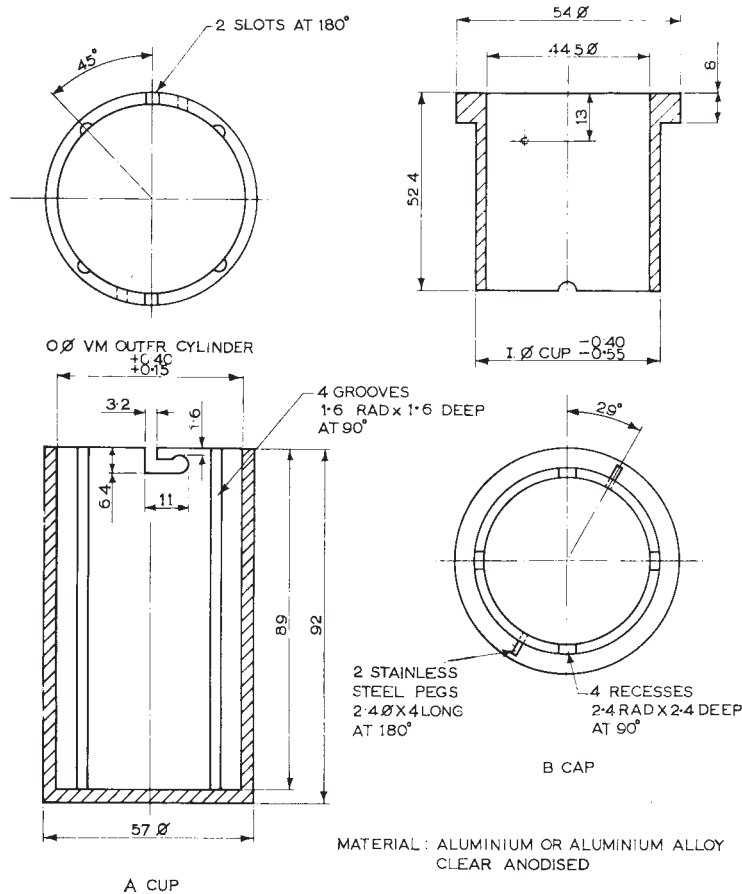

FIG. 1 Details of Oil Container for Viscosity Determinations

6.3 *Three-Speed Portable Viscometer Model VH*,⁴ fitted with a 2 mN·m (20 gf·cm) spring and a Model VM outer cylinder having a plastic shaft and B inner cylinder (Fig. 2). A viscometer should be selected having a Multiplying Factor, that is, a viscometer factor, of not less than 0.25 P per division.

6.3.1 Four 5-mm (³/₁₆-in.) holes are drilled symmetrically into the top of both the Model VM outer cylinder and guard ring, to allow oil to flow easily into the gap between the cylinders.

6.4 *Water Bath*, of any convenient size or shape such that the oil container can be immersed in it and the Ferranti viscometer can be placed in an operating position with the container in the bath. The bath shall be capable of being maintained at a temperature of 82 ± 1°C (180 ± 2°F).

6.5 *Water Bath*, similar to 6.4 which can be maintained at 10, 20, 30, 40, 50, and 55 ± 0.5°C. The bath must also be capable of being cooled at 0.5°C/min (1°F/min) to 2°C (35°F) such that at any time the temperature does not differ from the required temperature by more than ±0.5°C.

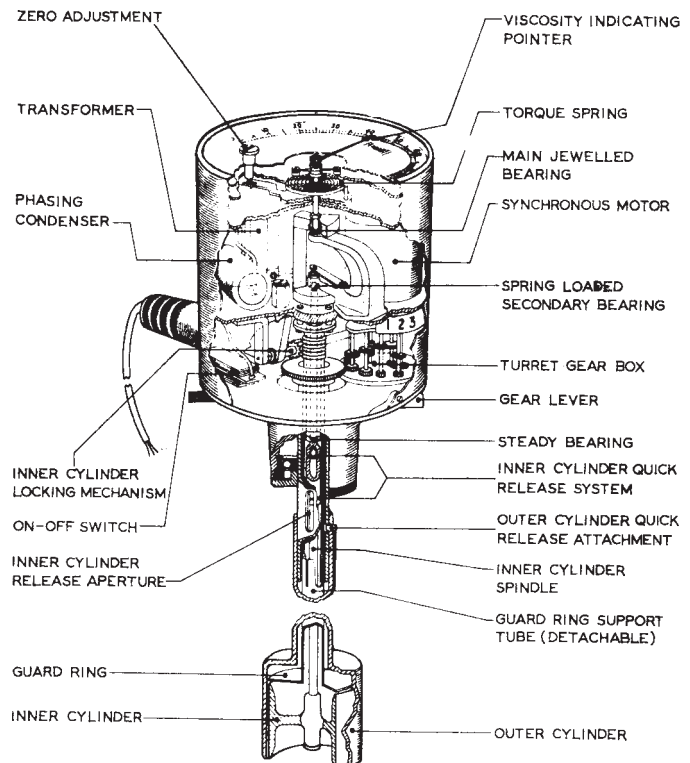

FIG. 2 3-Speed Portable Viscometer Model VH

⁴ The sole source of supply of the apparatus known to the committee at this time is Ravenfield Designs, Ltd., Russell St., Heywood, Lancs., OL10 1NX, England. If you are aware of alternative suppliers, please provide this information to ASTM Headquarters. Your comments will receive careful consideration at a meeting of the responsible technical committee,¹ which you may attend.

7. Hazards

7.1 Fuel oil samples to be tested are combustible and require cautious handling as indicated in A2.1.

8. Procedure

8.1 Fill the oil cup with the sample at a temperature not exceeding 82°C (180°F) to a depth of 60 mm (2¼ in.). Gently slide the oil container back onto the viscometer and lock in position with the cap. Place the assembly in its working position in the water bath maintained at 82 ± 1°C. After 5 min, remove excess oil above the level of the top of the outer cylinder. A bent pipet is suitable for this purpose. Further slight expansion of the oil should be ignored.

8.1.1 The oil may be heated to a temperature not exceeding 82°C to make it pour easily into the viscometer. If a hot plate is used to warm the sample, care must be exercised to continuously stir the sample and ensure that the surface temperature does not exceed 82°C (180°F).

8.2 After 20 min, transfer the viscometer assembly to the bath set at the predetermined chilling temperature (see Table 1).

8.3 After 15 min, start the viscometer with the gear change lever at Speed 3.

8.4 After a further 5 min, cool the bath at 0.5°C/min such that at any time the temperature does not differ from the required temperature by more than ±0.5°C.

8.5 Every 2.5 min, note the scale deflection to the nearest 0.5 division and bath temperature to the nearest 0.1°C. Convert the scale deflection to viscosity in poise by multiplying by the appropriate viscometer factor (see Annex A1). Record viscosities to the nearest 0.01 Pa·s (0.1 P).

8.6 Continue until the full-scale deflection of the instrument is reached or until the bath temperature has fallen to 2°C.

8.6.1 If it is desired to obtain 2.5 Pa·s (25 P) temperatures below 4°C, cooling shall be maintained at the same rate until the full-scale deflection is reached. An appropriate cooling bath will be required in place of the water bath (6.5).

8.7 Plot the curve of viscosity versus bath temperature on linear scales and read off the bath temperatures corresponding to viscosities of 0.6 Pa·s (6 P) and 2.5 Pa·s (25 P).

8.8 If the 0.6 Pa·s (6 P) temperature is above the predetermined intermediate chilling temperature, repeat the whole test on a fresh sample using the intermediate chilling temperature for the next higher viscosity level. If it is known from previous experience that the chilling temperature for the higher viscosity level will be required, it is not necessary to carry out the test at the lower level.

8.9 To allow for the difference between the bath temperature and the oil temperature, add 2°C to the bath temperatures corresponding to 0.6 and 2.5 Pa·s (6 and 25 P). These adjusted temperatures are the 0.6 and 2.5 Pa·s (6 and 25 P) temperatures for the oil.

9. Report

9.1 Report the 0.6 Pa·s (6 P) temperatures as the handling point. Record to the nearest 0.1°C (0.2°F).

9.2 Report the 2.5 Pa·s (25 P) temperature as the storage point. If the 25 P temperature was not reached at 4°C (39°F), report as “less than 4°C (39°F).” Report to the nearest 0.1°C (0.2°F).

10. Precision and Bias

10.1 *Precision*—The precision of this test method as determined by statistical examination of interlaboratory results is as follows:

10.2 *Repeatability*—The difference between two test results obtained by the same operator with the same apparatus under constant operating conditions on identical test material would, in the long run, in the normal and correct operation of the test method, exceed the following values only in one case in twenty:

0.6 Pa·s (6 P) temperature	0.5°C
2.5 Pa·s (25 P) temperature	0.5°C

10.3 *Reproducibility*—The difference between two single and independent results obtained by different operators working in different laboratories on identical test material would, in the long run, in the normal and correct operation of the test method, exceed the following values only in one case in twenty:

0.6 Pa·s (6 P) temperature	2.9°C
2.5 Pa·s (25 P) temperature	4.0°C

10.4 These precision values have been obtained by statistical examination of interlaboratory test results between the ASTM and IP and include data from 20 laboratories on seven samples. Tests were conducted under coordination of Subcommittees D02.E0.04 and D02.07.0D.

10.5 *Bias*—There being no established criteria for measuring bias in these materials, no statement of bias can be made.

11. Keywords

11.1 handling point; industrial fuel; pumpability; storage point

TABLE 1 Determination of Intermediate Chilling Temperature

Kinematic Viscosity Range, mm ² /S (cSt) at 50°C (122°F)	Temperature of Bath into which Viscometer Assembly is Transferred after 20 min in 82°C (180°F) Bath
370–570	55°C (125°F)
227–370	50°C (115°F)
125–227	40°C (100°F)
67–125	30°C (85°F)
36–67	20°C (65°F)
36	10°C (50°F)

ANNEXES**(Mandatory Information)****A1. CALIBRATION OF VISCOMETER****A1.1 Time Between Successive Calibrations**

A1.1.1 The viscometer must be calibrated at least once every three months.

A1.2 Apparatus

A1.2.1 *Water Bath*, capable of being maintained at a temperature in each of the ranges from 20 to 25°C and 35 to 40°C within $\pm 0.1^\circ\text{C}$. The baths specified in 6.4 or 6.5 may be satisfactory.

A1.3 Reference Oil

A1.3.1 A reference mineral oil should be used having viscosities close to 0.6 Pa·s (6 P) at temperatures in the range from 35 to 40°C and close to 2.5 Pa·s (25 P) in the range from 20 to 25°C. The viscosities at one temperature in each range must have been determined recently by Test Method D 445.

NOTE A1.1—An oil such as SAE 140 is suitable for this purpose. So that the full-scale deflection of the viscometer is not exceeded at the lower temperature it is advisable to use an oil with a viscosity at the lower end of the SAE 140 range.

A1.4 Calibration

A1.4.1 As described in 8.1, fill the cup with the reference oil and assemble in a working position in a water bath maintained within 0.1°C of one of the temperatures selected in A1.2.1. After 30 min start the viscometer with the gear level set at speed 3. Note the scale deflection every 2 min and record the steady deflection which is obtained. Repeat the calibration at the other temperature used in A1.3.1.

A1.5 Calculation

A1.5.1 Obtain the viscometer factor at 35°C and 20°C by dividing the viscosity in poise (or pascal-seconds) by the appropriate scale deflection. The mean of these results is the viscometer factor for the Ferranti viscometer.

A1.6 Precision

A1.6.1 From an analysis of viscometer factors determined during the cooperative program to establish the precision of the test method, it is expected that the difference between the calibration factors at the two temperatures of calibration would not be more than 0.0015 Pa·s per division (0.015 P per division) (95 % confidence).

A2. WARNING STATEMENT**A2.1 Combustible Liquid**

A2.1.1 (**Warning**—Combustible. Vapor harmful. Keep away from heat, sparks, and open flame. Keep container

closed. Use with adequate ventilation. Avoid prolonged breathing of vapor or spray mist. Avoid prolonged or repeated skin contact.)

SUMMARY OF CHANGES

Subcommittee D02.07 has identified the location of selected changes to this standard since the last issue (D 3245–96) that may impact the use of this standard.

(1) Added Specification E 1 to Section 2, Referenced Documents.

(2) Corrected 6.1 with information on temperature measuring device.

ASTM International takes no position respecting the validity of any patent rights asserted in connection with any item mentioned in this standard. Users of this standard are expressly advised that determination of the validity of any such patent rights, and the risk of infringement of such rights, are entirely their own responsibility.

This standard is subject to revision at any time by the responsible technical committee and must be reviewed every five years and if not revised, either reapproved or withdrawn. Your comments are invited either for revision of this standard or for additional standards and should be addressed to ASTM International Headquarters. Your comments will receive careful consideration at a meeting of the responsible technical committee, which you may attend. If you feel that your comments have not received a fair hearing you should make your views known to the ASTM Committee on Standards, at the address shown below.

This standard is copyrighted by ASTM International, 100 Barr Harbor Drive, PO Box C700, West Conshohocken, PA 19428-2959, United States. Individual reprints (single or multiple copies) of this standard may be obtained by contacting ASTM at the above address or at 610-832-9585 (phone), 610-832-9555 (fax), or service@astm.org (e-mail); or through the ASTM website (www.astm.org).