



# Standard Test Method for Chipping Resistance of Coatings<sup>1</sup>

This standard is issued under the fixed designation D 3170; the number immediately following the designation indicates the year of original adoption or, in the case of revision, the year of last revision. A number in parentheses indicates the year of last reapproval. A superscript epsilon ( $\epsilon$ ) indicates an editorial change since the last revision or reapproval.

*This standard has been approved for use by agencies of the Department of Defense.*

## 1. Scope

1.1 This test method covers the determination of the resistance of coatings to chipping damage by stones or other flying objects.

NOTE 1—This test method is similar to SAE J-400.

1.2 The values stated in metric units are to be regarded as the standard. The English units given in parentheses are for information only. All dimensions are nominal unless otherwise specified.

1.3 *This standard does not purport to address all of the safety concerns, if any, associated with its use. It is the responsibility of the user of this standard to establish appropriate safety and health practices and determine the applicability of regulatory limitations prior to use.*

## 2. Referenced Documents

### 2.1 ASTM Standards:

D 609 Practice for Preparation of Cold-Rolled Steel Panels for Testing Paint, Varnish, Conversion Coatings, and Related Coating Products<sup>2</sup>

D 823 Practices for Producing Films of Uniform Thickness of Paint, Varnish, and Related Products on Test Panels<sup>2</sup>

D 1005 Test Methods for Measurement of Dry-Film Thickness of Organic Coatings Using Micrometers<sup>2</sup>

D 1186 Test Methods for Nondestructive Measurement of Dry Film Thickness of Nonmagnetic Coatings Applied to a Ferrous Base<sup>2</sup>

D 1400 Test Method for Nondestructive Measurement of Dry Film Thickness of Nonconductive Coatings Applied to a Nonferrous Metal Base<sup>2</sup>

D 1733 Method of Preparation of Aluminum-Alloy Panels for Testing Paint, Varnish, Lacquer, and Related Products<sup>3</sup>

D 2201 Practice for Preparation of Zinc-Coated and Zinc-Alloy-Coated Steel Panels for Testing Paint and Related Products<sup>2</sup>

### 2.2 Other Documents:

Test for Chip Resistance of Surface Coatings (J-400)<sup>4</sup>  
*Chipping Rating Standards*<sup>4</sup>

## 3. Summary of Test Method

3.1 Standardized road gravel is projected by means of a controlled air blast at the coated specimens. All testing is conducted under controlled temperature conditions, generally either at ambient (room) temperature or at  $-29^{\circ}\text{C} \pm 3^{\circ}\text{C}$  ( $-20^{\circ} \pm 5^{\circ}\text{F}$ ). After the gravel impact, tape is applied to remove any loose coating chips and the degree of chipping is determined.

## 4. Significance and Use

4.1 Owners consider chipping of coatings, particularly on the leading faces and edges of automobile surfaces, unacceptable. In formulating a coating or coating system to meet service requirements, the resistance to chipping damage by flying objects such as gravel is one of the properties of importance since it can vary considerably as other properties are adjusted. Since resistance to chipping decreases at lower temperatures partly as the result of decreased flexibility, the test may be more directly related to service conditions by performing it at a low temperature. This test method is designed to produce a controlled amount of impact by the media on the coated panel in order to enhance reproducibility.

## 5. Apparatus

5.1 *Gravel-Projecting Machine (Gravelometer)*, constructed according to the design specifications shown in Fig. 1.<sup>5</sup> There are two types of Gravelometers: the old cabinet style and the newer, modular style with an electronic feed mechanism.

NOTE 2—It is recommended that the operation/maintenance checklist shown in Appendix X1 should be completed at least once per month for gravelometers that are operated on a weekly basis, and once every 6 months for gravelometers that are operated less frequently. Note that values in the checklist are specific to the standard gravel testing protocol. Different specifications may be necessary for other media types.

<sup>1</sup> This test method is under the jurisdiction of ASTM Committee D01 on Paint and Related Coatings, Materials, and Applications and is the direct responsibility of Subcommittee D 01.55 on Factory-Applied Coatings on Preformed Products.

Current edition approved May 10, 2001. Published July 2001. Originally published as D 3170 – 73. Last previous edition D 3170 – 74 (1996) <sup>$\epsilon$ 1</sup>.

<sup>2</sup> *Annual Book of ASTM Standards*, Vol 06.01.

<sup>3</sup> Discontinued, see 1980 *Annual Book of ASTM Standards*, Part 27.

<sup>4</sup> Available from the Society of Automotive Engineers, 400 Commonwealth Dr., Warrendale, PA 15096.

<sup>5</sup> The sole source of a suitable apparatus meeting these specifications known to the committee at this time is Q-Panel Co., 26200 First St., Westlake, OH 44135. If you are aware of alternative suppliers, please provide this information to ASTM Headquarters. Your comments will receive careful consideration at a meeting of the responsible technical committee,<sup>1</sup> which you may attend.

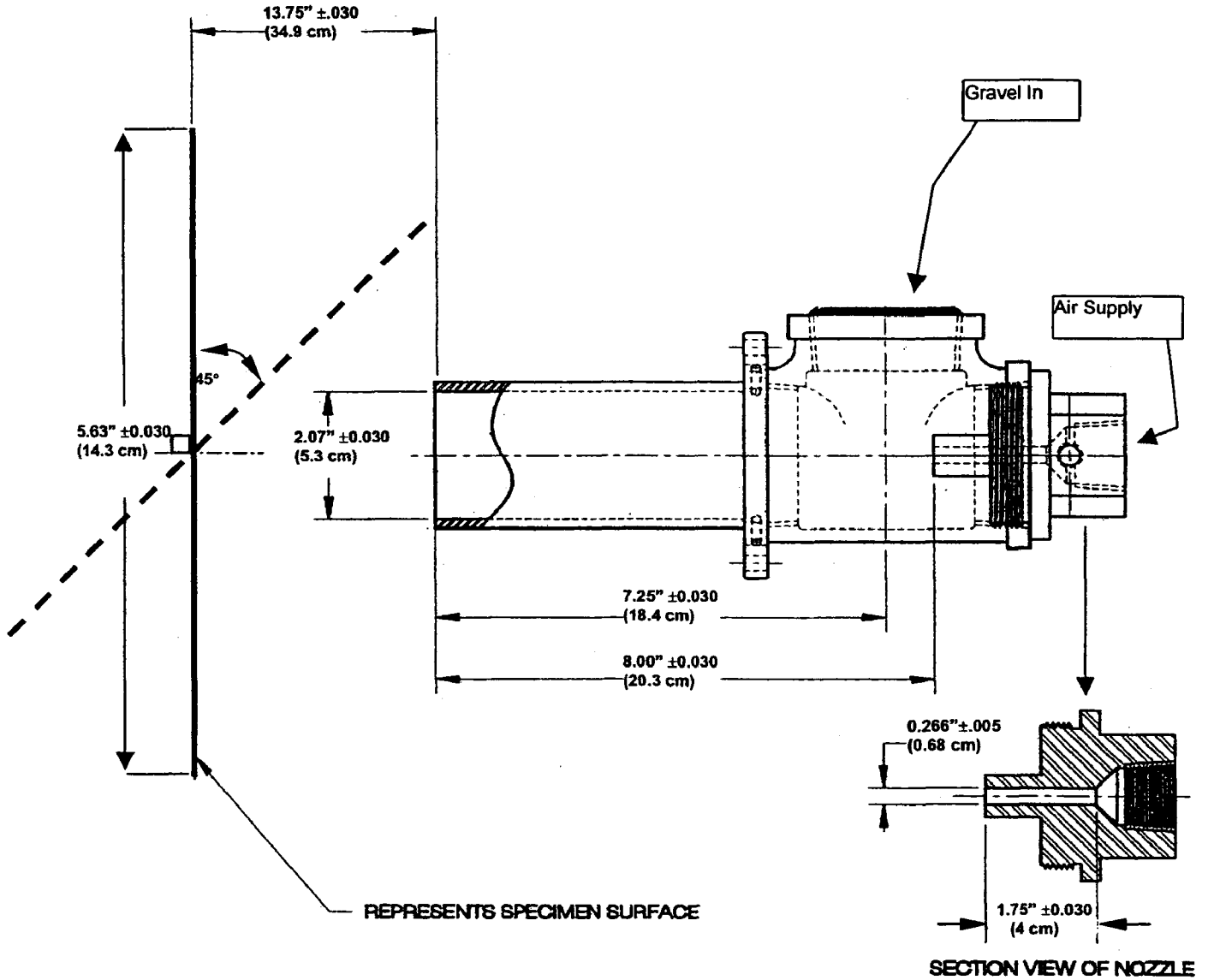

FIG. 1 Gravel Projecting Machine

5.2 *Gravel*—Water-eroded alluvial road gravel<sup>6</sup> passing through a 16-mm (5/8-in.) space screen but retained on a 9.5-mm (3/8-in.) space screen. Note that mesh screen is not a substitute for a space screen. It is important to remove the small pieces of gravel before reusing the gravel. Other media may be used as agreed by contractual parties.

5.3 *Tape*, 100 mm (4 in.) wide.<sup>7</sup> Other tape may be used as agreed upon by the contractual parties.

<sup>6</sup> The sole source of supply of gravel meeting these specifications known to the committee at this time is Q-Panel Co. If you are aware of alternative suppliers, please provide this information to ASTM Headquarters. Your comments will receive careful consideration at a meeting of the responsible technical committee,<sup>1</sup> which you may attend.

<sup>7</sup> The sole source of supply of No. 898 filament strapping tape known to the committee at this time is the 3M Co., St. Paul MN 55101. If you are aware of alternative suppliers, please provide this information to ASTM Headquarters. Your comments will receive careful consideration at a meeting of the responsible technical committee,<sup>1</sup> which you may attend.

5.4 *Temperature-Conditioning Equipment (alternatives):*

5.4.1 A cold room or freezer of sufficient size in which the gravel-projecting machine and test specimens can be maintained at the specified temperature of testing.

5.4.2 A freezer or cooler in which the test panels can be cooled 5°C (10°F) below the specified test temperature.

5.4.3 *Ambient*—Room maintained at a temperature between 20°C (68°F) and 30°C (86°F).

5.5 *Transparent Grid*—A chip counting aid constructed of transparent plastic approximately 3.176 mm thick by 12.7 cm square (1/8 by 5 by 5 in.), on which a 10.16 cm by 10.16 cm (4 by 4 in.) grid of 2.54 cm (1 in.) squares has been etched or scribed.

5.6 *Chipping Rating Standards*—A photographic transparency<sup>4</sup> depicting size and number of chips in each category. See Fig. 2, Fig. 3, Fig. 4, and Fig. 5 for a representation of this transparency.

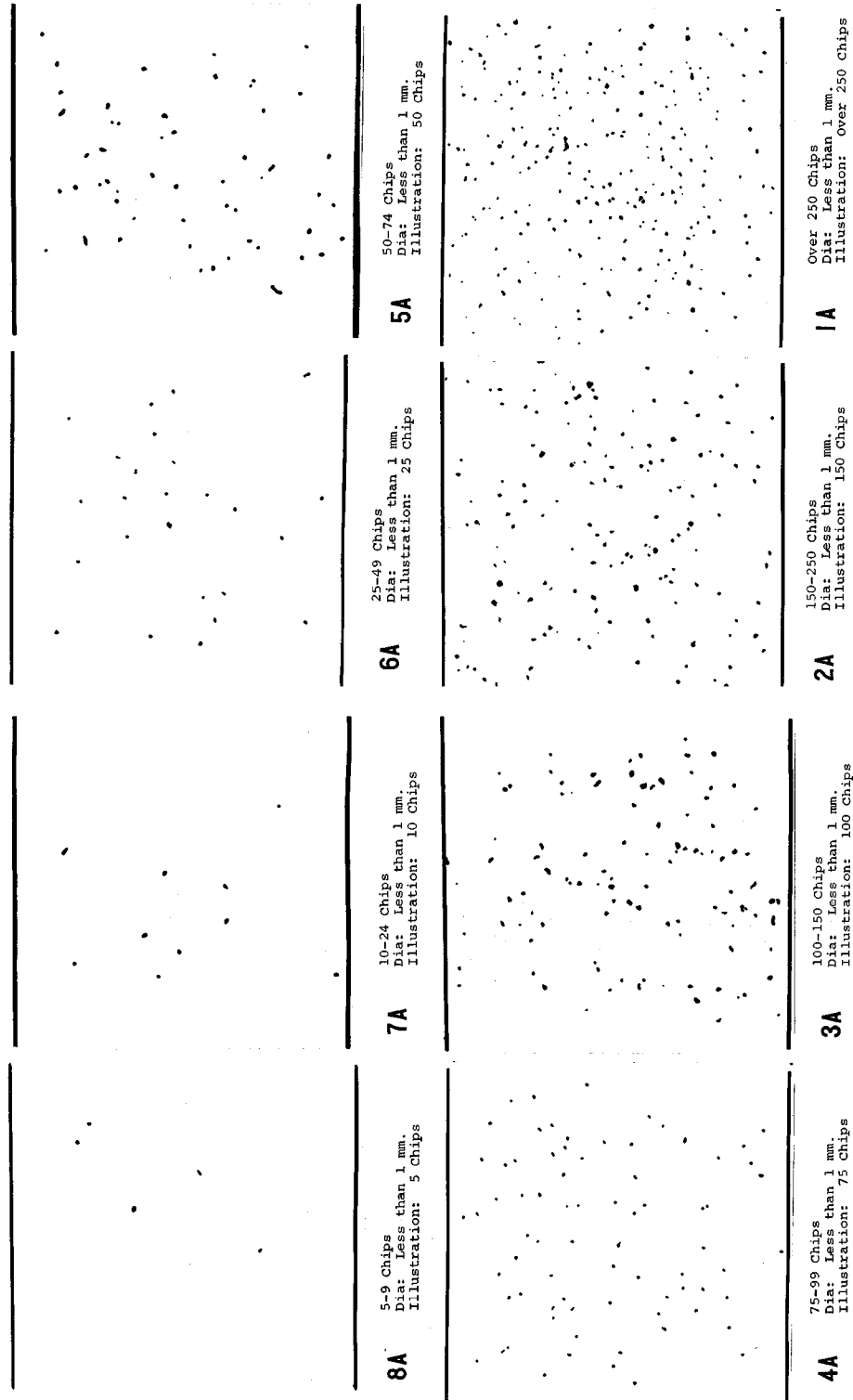

NOTE 1—Reprinted with permission from SAE EA-400 (c) 1985, Society of Automotive Engineers, Inc.

**FIG. 2 Representation of Chipping Ratings**

**6. Test Specimens**

6.1 The composition, surface preparation, and size of specimens shall be agreed upon between the purchaser and the seller. Test panels of 102 by 305 mm (4 by 12 in.) are commonly used.

NOTE 3—It is recommended that three replicates of each test specimen be exposed in the gravimeter. More replicates will improve the accuracy.

6.2 The number, type, method of application, and aging of

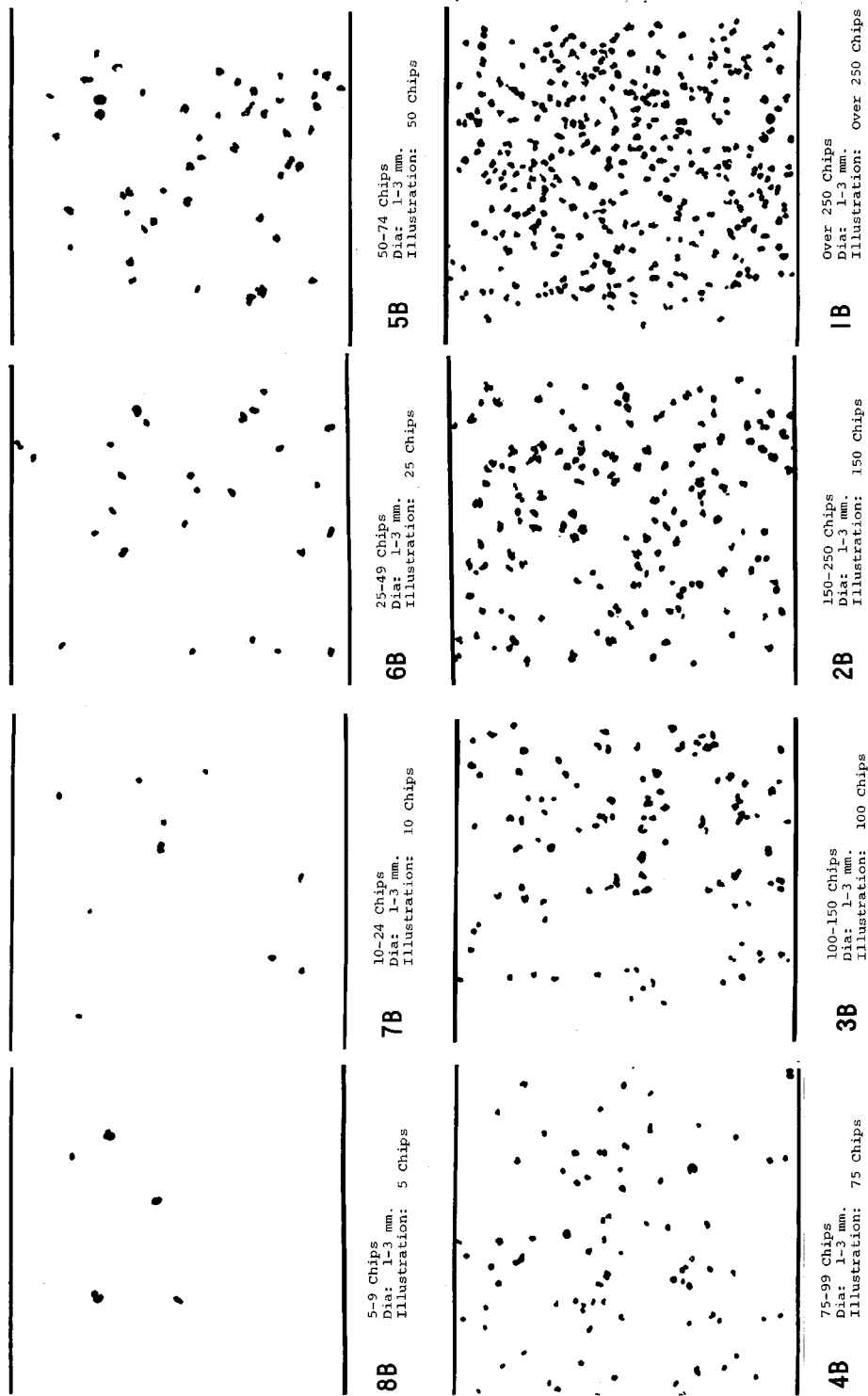

FIG. 3 Representation of Chipping Ratings, *Continued*

coatings shall be agreed upon between the purchaser and the seller.

NOTE 4—Application, metal preparation, and film thickness measurement methods are given in the following ASTM Practices: D 609, D 823 and D 2201, and Test Methods D 1005, D 1186, D 1400, and D 1733.

## 7. Procedure

7.1 Condition the specimens for a minimum of 1 h at the specified test temperature in the equipment specified in 5.4. Make certain the test specimens are separated and have free

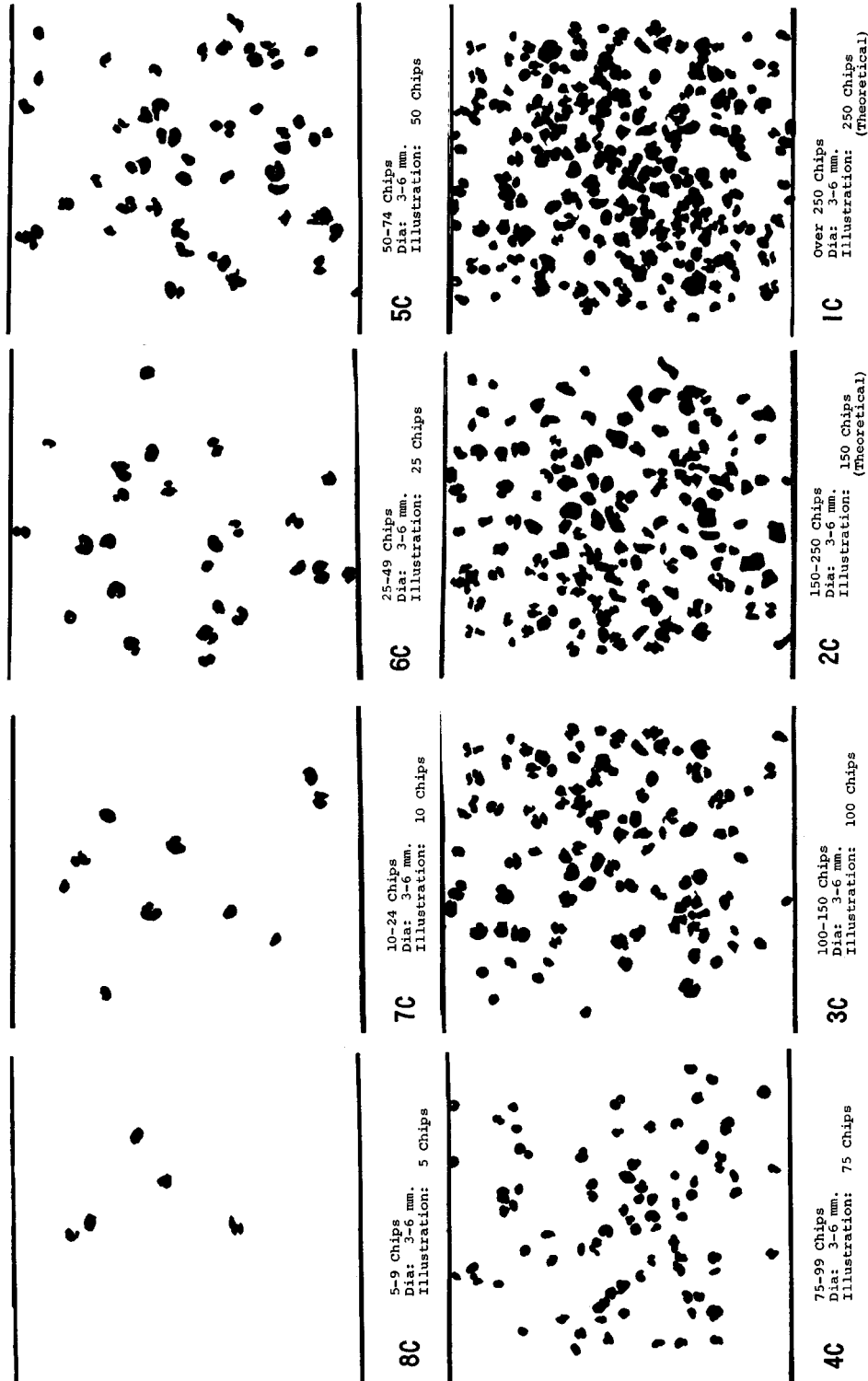

FIG. 4 Representation of Chipping Ratings, Continued

access to the conditioning environment so that optimum heat transfer occurs.

7.2 Adjust the air pressure on the gravel apparatus to  $480 \pm 20$  kPa ( $70 \pm 3$  psi) with the air valve open.

NOTE 5—For cabinet type gravelometers, keep the lid to the gravel chamber closed during this operation as a safety precaution. Other air

pressures can be used as agreed upon by the contractual parties.

### 7.3 Cabinet Style Gravelometer:

7.3.1 After adjusting the air pressure, shut off the air valve, open the lid to the gravel chamber and collect 550 mL (1 pt) of graded gravel (approx 250 to 3000 stones) in a suitable container. Collect the gravel by scraping across the screen to

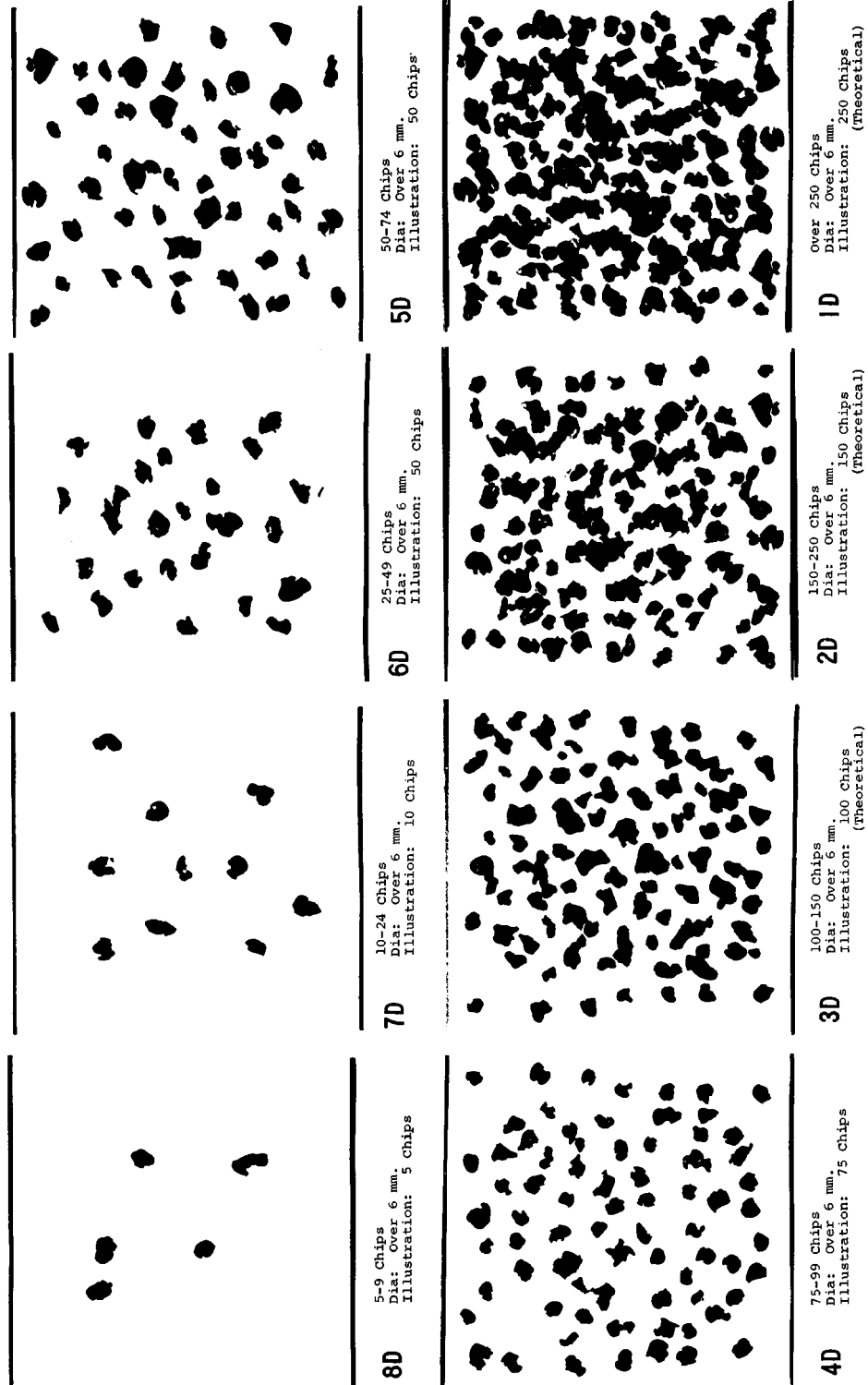

FIG. 5 Representation of Chipping Ratings, *Continued*

allow fines to fall through.

7.3.2 Place one test specimen at the desired test temperature in the panel holder with the coated side facing the front of the apparatus and close the lid to the panel chamber.

7.3.3 Open the gravel feed door and pour gravel from the one pint container obtained from 7.3.1 into the top of the gravel

hopper. Do not allow gravel to fall into the nozzle entrance.

7.3.4 Open the air valve to allow the air to project the gravel at the specimen.

NOTE 6—The gravel hopper must empty in 7 to 10 s. If gravel remains in the hopper after 10 s, stop the test and investigate the cause. The

operator should not touch the gravel during the test or otherwise physically help the gravel into the funnel.

NOTE 7—It is important to know that the vibrator may become frozen when the chamber is installed in a cold room or freezer. If the vibrator is frozen, discontinue the test until the vibrator has thawed and is operating correctly.

7.3.5 Shut the air valve, open the lid to the specimen chamber and remove the specimen.

7.4 Modular Style Gravelometer:

7.4.1 After adjusting the air pressure, shut off the air valve, open the lid to the gravel hopper and pour 550 ml (1 pt) of graded gravel (approx. 250 to 3000 stones) into the top of the gravel hopper.

7.4.2 Pull back on the specimen mounting clamp to open the specimen holder on the holder assembly. Place one test specimen at the desired test temperature in the panel holder with the coated side facing the front of the apparatus. Clamp to close the specimen holder.

7.4.3 Set the test timer.

NOTE 8—There are two ways to operate a test on the Modular style gravelometer. A timed test is a test that shuts off the machine after a preset amount of time has passed. A manual test requires the operator to shut off the machine after the desired amount of time has passed.

7.4.3.1 Timed Test:

7.4.3.1.1 Make sure that the control switch is set to stop.

7.4.3.1.2 Set the test timer to the desired test time. A typical test time is 10 s.

7.4.3.1.3 Turn the main power switch on.

7.4.3.1.4 Turn the control switch to Timed Start.

7.4.3.2 Manual Test:

7.4.3.2.1 Make sure that the control switch is set to stop.

7.4.3.2.2 Turn the main power switch on.

7.4.3.2.3 Turn the control switch to Manual.

7.4.3.2.4 After the desired amount of time has passed the control switch to Off.

NOTE 9—Manual mode requires the operator to manually stop the test. Once started, the test will not stop by itself.

7.4.4 When the test has been completed, remove the test panel from the specimen holder by pulling back on the Specimen Mounting Clamp and removing the test specimen.

7.4.5 Remove the gravel from the return receptacle and screen before reuse.

7.5 Allow the test specimens to return to room temperature and dry with a soft cloth to remove any condensation.

7.6 Use the tape referenced in 5.3 to remove all loose or damaged paint.

7.6.1 Cover the test area of the specimen with a strip(s) of tape. Apply uniform pressure to ensure that the tape is firmly adhered to the specimen. There should not be any air bubbles trapped beneath the tape.

NOTE 10—Uniform pressure can be applied by using a pencil eraser or tongue depressor.

7.6.2 Remove the tape by pulling straight up.

7.6.3 Apply new strips of tape as specified in 7.6.1.

7.6.4 Remove the tape by pulling straight up in the opposite direction to 7.6.2.

7.6.5 Continue this procedure using new strips of tape until all loose or damaged paint is removed.

NOTE 11—Other tapes or loose paint removal methods may be used as agreed upon by contractual parties.

8. Chip Rating Systems

8.1 There are two generally accepted methods for determining the degree of chipping on the test panel. In the first method, the exact number of chips in each size range is tabulated for the test area. The second method utilizes a visual comparison of the test panel to the *Chipping Rating Standards* represented in Fig. 2, Fig. 3, Fig. 4, and Fig. 5. These standards depict various degrees of chipping severity and are arranged sequentially from best to worst according to chipping frequency.

NOTE 12—The first method, while the most time consuming, is the most precise and should be used where definitive accuracy is required or as the referee method in case differences arise between laboratories. The second method, while more of an approximation than the first method, can be used for many routine laboratory evaluations where the accuracy of the first method is not required. The second method also lends itself to field survey work where the chipped areas can be rated by direct comparison with the *Chipping Rating Standards*.

NOTE 13—Other rating methods may be employed as agreed upon by contractual parties. The evaluation may also be carried out using digital optical imaging which offers further possibilities of evaluation and reproducibility. A guide for use of digital optical imaging is being prepared by ASTM Subcommittee D01.25.

8.2 The chipped area to be evaluated on the test specimen should be the 10.2 by 10.2 cm (4 by 4 in) square that is the center of the chipped area.

8.3 The chip rating system consists of one or more number-letter combinations in which the numbers indicate the number of chips and the letters designate the size of the corresponding chips. A point of failure notation may also be included in the rating if a more descriptive statement is desired.

8.3.1 *Number of Chips*—A number, as shown in Table 1, from 10–0 that is used to indicate the number size in the 10.2 by 10.2 cm (4 by 4 in) test area.

8.3.2 *Size of Chips*—A letter, as shown in Table 2, from A–D that is used to indicate the size of the chip. Due to the irregular nature of chipping, the size cannot always be measured exactly so it has to be approximated.

8.3.3 *Point of Failure Notation*—The coating layer, as shown in Table 3, at which the most predominate chipping failure occurs is designated as the point of failure.

NOTE 14—Cohesional failures are failures within a coating. Adhesional failures are failures between coatings.

TABLE 1 Number Categories for Chip Ratings

Rating Number	Number of Chips
10	0
9	1
8	2–4
7	5–9
6	10–24
5	25–49
4	50–74
3	75–99
2	100–149
1	150–250
0	>250

**TABLE 2 Size Categories for Chip Ratings**

Rating Letter	Size of Chips
A	<1 mm (approximately 0.03 in.)
B	1–3 mm (approximately 0.03–0.12 in.)
C	3–6 mm (approximately 0.12–0.25 in.)
D	>6 mm (approximately 0.25 in.)

**TABLE 3 Point of Failure Notation**

Notation	Level of Failure	Failure Type
(S/P)	Substrate to Primer	Adhesional
(S/T)	Substrate to Topcoat	Adhesional
(P)	Primer	Cohesional
(P/T)	Primer to Topcoat	Adhesional
(T)	Topcoat	Cohesional

## 9. Physical Count Procedure

9.1 Place the transparent grid, as described in 5.5, over the area to be measured.

9.2 The operator examines the area within a 2.54 by 2.54 cm (1 by 1 in.) square and determines the size of each chip as encountered and records it. Repeat for all 16 squares and record the results.

9.3 Convert the number of chips encountered for each size into the number-letter combinations using Tables 1 and 2. The number-letter combinations are arranged with the most numerous size first, followed by the next most numerous, and so forth. This may be followed by the point of failure notation.

NOTE 15—An example of how this procedure is used is shown in Appendix X2.

## 10. Visual Comparison Procedure

10.1 Utilize the *Chipping Rating Standards* represented in Fig. 2, Fig. 3, Fig. 4, and Fig. 5. The standards have been prepared so that chips of only one size are shown in each illustration. The number of chips illustrated in each standard is the fewest number of chips in each rating number category, for example, the No. 5 standards show 25 chips, the No. 3 standard

shows 75 chips, and so forth.

10.2 Visually compare the area to be rated with the standards.

10.2.1 Since each standard represents only one chip and actual chipping seldom occurs in only one size, one or more standards should be superimposed until that combination of standards that most resembles the specimen is obtained.

10.2.2 Record the standards that were used to achieve the match with the panel under examination.

10.3 As with the physical count procedure, the most numerous size first, followed by the next most numerous, etc. This may be followed by the point of failure notation.

NOTE 16—An example of how this procedure is used is shown in Appendix X2.

## 11. Report

11.1 Report the substrate composition, type and age of coating, test temperature, and the number-letter rating.

## 12. Precision and Bias

12.1 *Precision*—Since the rating scale consists of a combination letter and number, no standard deviation number is obtainable. It is the judgement of those familiar with this test method that the following precision statements are representative:

12.1.1 *Repeatability*—Results of tests within a laboratory differing by more than one number or letter unit should be considered suspect.

12.1.2 *Reproducibility*—Results of tests between laboratories differing by more than two number or letter units should be considered suspect.

12.2 *Bias*—Since there is no acceptable reference procedure for determining bias using this test method, no statement is being made.

## 13. Keywords

13.1 chipping resistance; gravelometer

## APPENDIXES

### (Nonmandatory Information)

#### X1. GRAVELOMETER OPERATION/MAINTENANCE CHECKLIST

X1.1 The operation/maintenance checklist that follows should be completed at least once a month for gravelometers that are operated on a weekly basis and once every 6 months for gravelometers that are operated less frequently.

NOTE X1.1—The values in the chart are specific to the standard gravel

testing protocol. Different specifications may be necessary for other media types.

X1.2 If the answer to any of the following questions is NO, discontinue testing until the problem has been corrected.



**Gravelometer Operation/Maintenance Checklist**

Question	Yes	No	Data
Is a pipe size ID of 2.54 cm (1 in) airline connected from the supply pipe to the gravelometer?			
Are the pipe joints free of leaks?			
Does the air pressure hold 483 kPa (70 ± 3 psi) for 10 secs?			
Is the air pressure gauge calibrated?			
Date Last Calibrated:			
Date Last Replaced:			
Is nozzle orifice clear? Insert a 6.75 mm (17/64 in) drill bit or 0.266 ± .005 in. plug gauge into nozzle to verify that the nozzle orifice is clear.			
Is the distance of nozzle to sample surface 55.25 cm (21.75 ± .030 in)?			
Is the distance of gun barrel to sample 34.93 cm (13.75 ± .030 in)?			
Is sample mounting bracket level top-to-bottom/front-back?			
Is the backer panel edge supported (not solid)?			
Is backer panel tight?			
Are the backer panel angles correct?			
Are stones hitting target in an even/centered pattern?			
Is the gravel screened?			
For older cabinet type gravelometers, is the amount of gravel collected on screen less than 10 pt.?			
Is the correct type and size of gravel being used?			
Does 1pt of gravel empty from the hopper in 7 to 10 seconds?			
Is the filter clear of obstructions?			
Date of last filter cleaning or replacement.			
For older type gravelometers, replace vibrator and bushings if gravel takes longer than 10 s to empty.			
For gravelometers with electronic feed mechanisms, adjust vibrator speed and hopper height so that hopper empties in 7 to 10 seconds.			
Compressor Capacity and Type:			

FIG. X1.1 Gravelometer Operation/Maintenance Checklist

**Below Ambient Temperature Testing Information (if required)**

Question	Yes	No	Data
Are panels frozen prior to testing?			
How long are panels conditioned in freezer?			
What is the conditioning temperature?			
What is the ambient temperature?			
Time panels exposed to ambient prior to test.			
How far is the QGR from freezer?			

FIG. X1.2 Below Ambient Temperature Testing Information (If Required)

**X2. EXAMPLES OF RATINGS**

*X2.1 Physical Count Procedure:*

X2.1.1 The test panel has 20 chips less than 1 mm (A size), 40 chips of 1 to 3 mm (B size) and 3 chips 3 to 6 mm (C size) with primer-topcoat failure.

X2.1.2 The rating would be 5B-6A-SC (P/T).

X2.1.3 The rating can be condensed by converting the total number of chips on the test panel to the corresponding number category, followed by the size designations in the same order.

In this example, with a total of 63 chips, the rating would be summarized as 4 BAC (P/T).

*X2.2 Visual Comparison Procedure:*

X2.2.1 The test panel has 20 chips less than 1 mm (A size), 40 chips of 1 to 3 mm (B size) and 3 chips of 3 to 6 mm (C size) with primer-topcoat failure.

X2.2.2 The rating would be 5B-6A-SC (P/T).

X2.2.3 The rating can be condensed by converting the total number of chips on the test panel to the corresponding number category, followed by the size designations in the same order.

In this example, with a total of 63 chips, the rating would be summarized as 4 BAC (P/T).

*The American Society for Testing and Materials takes no position respecting the validity of any patent rights asserted in connection with any item mentioned in this standard. Users of this standard are expressly advised that determination of the validity of any such patent rights, and the risk of infringement of such rights, are entirely their own responsibility.*

*This standard is subject to revision at any time by the responsible technical committee and must be reviewed every five years and if not revised, either reapproved or withdrawn. Your comments are invited either for revision of this standard or for additional standards and should be addressed to ASTM Headquarters. Your comments will receive careful consideration at a meeting of the responsible technical committee, which you may attend. If you feel that your comments have not received a fair hearing you should make your views known to the ASTM Committee on Standards, at the address shown below.*

*This standard is copyrighted by ASTM, 100 Barr Harbor Drive, PO Box C700, West Conshohocken, PA 19428-2959, United States. Individual reprints (single or multiple copies) of this standard may be obtained by contacting ASTM at the above address or at 610-832-9585 (phone), 610-832-9555 (fax), or [service@astm.org](mailto:service@astm.org) (e-mail); or through the ASTM website ([www.astm.org](http://www.astm.org)).*