



# Standard Test Method for Reaction Threshold Temperature of Liquid and Solid Materials<sup>1</sup>

This standard is issued under the fixed designation D 2883; the number immediately following the designation indicates the year of original adoption or, in the case of revision, the year of last revision. A number in parentheses indicates the year of last reapproval. A superscript epsilon ( $\epsilon$ ) indicates an editorial change since the last revision or reapproval.

<sup>ε1</sup> NOTE—Warning notes were placed in the text editorially in November 2000.

## 1. Scope

1.1 This test method covers determination of the pre-flame, cool-flame, and hot-flame reaction threshold temperatures and the incipient reaction temperature of liquids and solids. Data may be obtained at pressures from low vacuum to 0.8 MPa (115 psia) for temperatures within the range from room temperature to 925 K (1200°F).

1.2 This test method may be applied to any substance that is a liquid or a solid at room temperature and atmospheric pressure and that, at room temperature, is compatible with glass and stainless steel. Air is the intended oxidizing medium; however, other media may be substituted provided appropriate precautions are taken for their safe use.

1.3 The values stated in SI units are to be regarded as the standard. In cases where materials, products, or equipment are available in inch-pound units only, SI units are omitted.

1.4 *This standard should be used to measure and describe the properties of materials, products, or assemblies in response to heat and flame under controlled laboratory conditions and should not be used to describe or appraise the fire hazard or fire risk of materials, products, or assemblies under actual fire conditions. However, results of this test may be used as elements of a fire risk assessment which takes into account all of the factors which are pertinent to an assessment of the fire hazard of a particular end use.*

1.5 *This standard does not purport to address all of the safety concerns, if any, associated with its use. It is the responsibility of the user of this standard to establish appropriate safety and health practices and determine the applicability of regulatory limitations prior to use.* For specific hazard statements, see 6.8, Sections 7 and 9.

## 2. Referenced Documents

### 2.1 ASTM Standards:

D 1193 Specification for Reagent Water<sup>2</sup>

D 2021 Specification for Neutral Detergent, 40 Percent Alkylbenzene Sulfonate Type<sup>3</sup>

E 659 Test Method for Autoignition Temperature of Liquid Chemicals<sup>4</sup>

### 2.2 Military Standards:<sup>5</sup>

MIL-C-81302 Trichlorotrifluoroethane

MIL-T-7003 Trichloroethylene

## 3. Terminology

### 3.1 Definitions of Terms Specific to This Standard:

3.1.1 *catalytic reaction, n*—a fast, self-sustaining, energetic, sometimes luminous, sometimes audible reaction that occurs as a result of catalytic action on the surface of the thermocouple or other solid surface within the combustion chamber.

3.1.2 *cool-flame reaction, n*—a relatively slow, self-sustaining, barely luminous reaction of the sample or its decomposition products with the atmosphere in the combustion chamber.

3.1.2.1 *Discussion*—This type of flame is visible only in a darkened area. Figs. 1-4 illustrate the type of temperature records obtained for cool-flames.

3.1.3 *hot-flame reaction, n*—a rapid, self-sustaining, luminous, sometimes audible reaction of the sample or its decomposition products with the atmosphere in the combustion chamber.

3.1.3.1 *Discussion*—A yellow or blue flame usually accompanies the reaction. Figs. 5-7 illustrate the type of temperature records obtained for hot-flames.

<sup>1</sup> This test method is under the jurisdiction of ASTM Committee D02 on Petroleum Products and Lubricants and is the direct responsibility of Subcommittee D02.11 on Engineering Sciences of High Performance Fluids and Solids.

Current edition approved Jan. 15, 1995. Published March 1995. Originally published as D2883 – 70 T. Last previous edition D2883 – 93.

<sup>2</sup> *Annual Book of ASTM Standards*, Vol 11.01.

<sup>3</sup> *Annual Book of ASTM Standards*, Vol 15.04.

<sup>4</sup> *Annual Book of ASTM Standards*, Vol 14.02.

<sup>5</sup> Available from Standardization Documents Order Desk, Bldg 4, Section D, 700 Robbins Ave., Philadelphia, PA 19111-5094. Attn: NPODS.

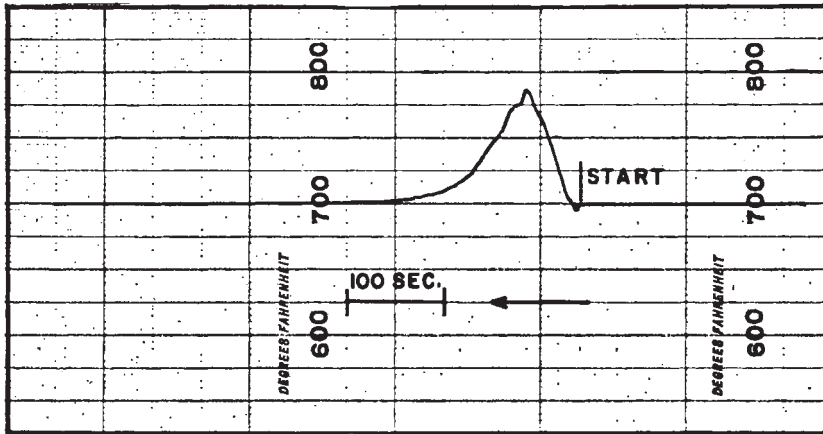

FIG. 1 Time-Temperature Profile for Typical Cool-Flame Reactions

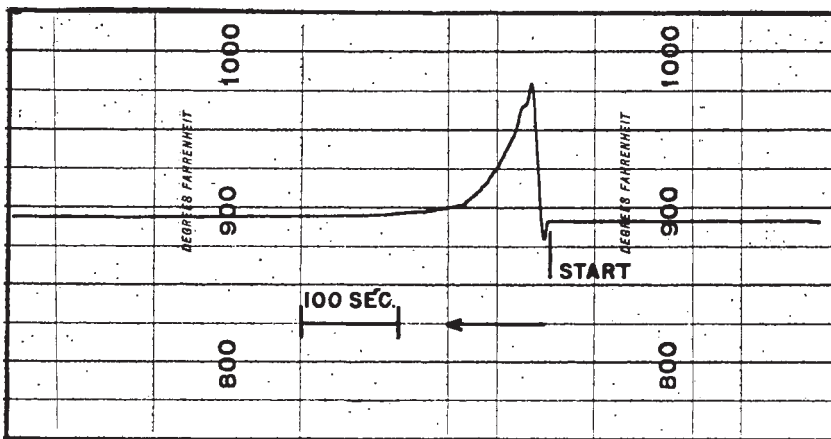

FIG. 2 Time-Temperature Profile for Typical Cool-Flame Reactions

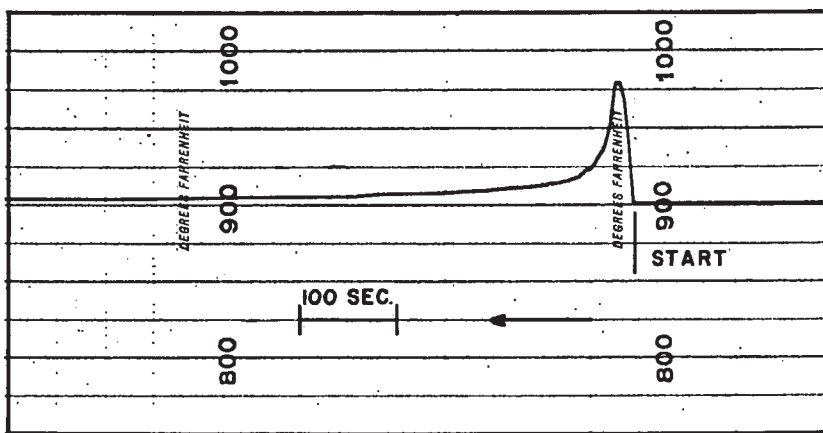

FIG. 3 Time-Temperature Profile for Typical Cool-Flame Reactions

3.1.4 *incipient reaction temperature, n*—the temperature obtained by extrapolation of a plot of the reciprocal of the reaction delay time versus the initial reaction temperature to that value of the reciprocal which represents infinite delay ( $t^{-1} = 0$ ) (Fig. 8).

3.1.4.1 *Discussion*—The detection of sample reactions and the distinctions between different reactions are based upon the records produced by the various sensing devices used in the apparatus. The temperature record is basic to the method and

shall be regarded as the primary source of such data. The use of a pressure record and the records of other sensing devices to obtain additional data is optional.

3.1.5 *noncombustive reaction, n*—a reaction other than combustion or thermal degradation undergone by certain materials upon exposure to elevated temperatures.

3.1.5.1 *Discussion*—Thermal polymerization is an example of the type of reaction that may occur when dealing with potentially reactive substances.

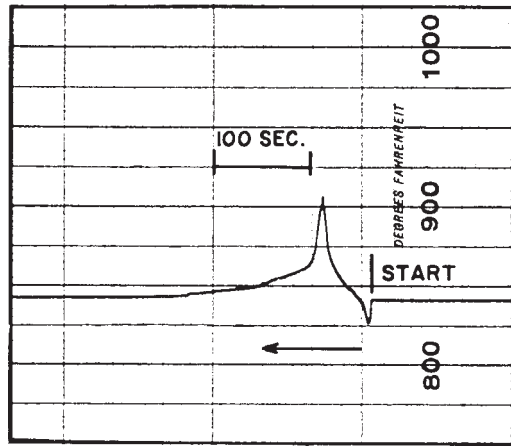

FIG. 4 Time-Temperature Profile for Typical Cool-Flame Reactions

3.1.6 *pre-flame reaction, n*—a slow, nonluminous reaction of the sample or its decomposition products with the atmosphere in the combustion chamber.

3.1.6.1 *Discussion*—Fig. 9 and Fig. 10 illustrate the type of temperature records obtained for preflame reactions.

3.1.7 *reaction delay time, n*—the time, measured in seconds, that elapses between the introduction of the sample into the reaction chamber and the attainment of maximum response from one of the sensors used to follow the reaction (Fig. 3).

3.1.8 *reaction threshold temperature, n*—the lowest temperature at which any reaction of the sample or its decomposition products may be detected by a thermocouple or other sensing devices.

### 3.2 Symbols:

- $T$  = temperature, °C
- $T^*$  = incipient reaction temperature, °C
- $t$  = delay time, s
- $P$  = pressure, Pa or torr
- $h$  = hot-flame reaction
- $c$  = cool-flame reaction
- $p$  = pre-flame reaction
- $c$  = catalytic reaction
- $n$  = noncombustion reaction

## 4. Summary of Test Method

4.1 A small measured amount of the sample contained in a glass ampoule is introduced into a stainless steel reaction chamber maintained at preselected temperature and pressure. The reactions of the sample subsequent to its introduction into the reaction chamber are followed by monitoring the temperature or the temperature and pressure (optional) of the reaction chamber as a function of time.

4.2 At any selected system pressure, the minimum temperature (reaction threshold temperature) required to produce a given reaction is determined as a function of the size of the sample employed. The delay times for cool-flame and hot-flame reactions are also measured. A plot of the reciprocal of the reaction delay time versus the initial reaction chamber temperature for a cool-flame or hot-flame reaction may be used to determine the incipient reaction temperature by extrapolation to infinite delay time ( $t^{-1} = 0$ ).

NOTE 1—The hot-flame reaction, cool-flame reaction, and reaction threshold temperature obtained by this test method may approximate those

temperatures obtained by Test Method E 659, for hot-flame autoignition, cool-flame autoignition, and reaction threshold temperature, respectively.

## 5. Significance and Use

5.1 The reaction thresholds of a material are a measure of the tendency of the material or its decomposition products to undergo gas phase reactions of various types. Hot-flame and cool-flame thresholds relate directly to reactions which are involved in autoignition phenomena. Pre-flame, catalytic and thermal polymerization thresholds also relate to autoignition in that they represent reactions which can be under some conditions the precursors of ignition reactions.

## 6. Apparatus<sup>6</sup>

6.1 *Oven*, fan-assisted air-circulating, with a 300 by 300 by 300 mm minimum volume, centrally located in the oven work space within which temperature uniformity shall be  $\pm 3$  K over the temperature range from room temperature to 925 K. A typical oven is detailed in the Appendix.

6.1.1 Temperature uniformity shall be determined by the following test: Eight thermocouples shall be arranged within the oven in such a manner that they shall be located at positions designated by the corners of a 300 mm cube. Awg No. 30, calibrated, bare junction iron-constantan or Chromel-Alumel thermocouples are suitable. Lead-in ports may be plugged with insulating material during the uniformity test.

6.2 *Reaction Temperature Apparatus*, assembly as shown in Fig. 11, comprising the following:

6.2.1 *Combustion Chamber*, 1000 mL round-bottom, long-neck, AISI Type 316 stainless steel flask with 25.4 mm (1-in.) Corning ferrule, as shown in Fig. 12.

6.2.2 *Pressure Control Manifold*, as shown in Fig. 13, consisting of:

6.2.2.1 *Thermocouple Gland*.<sup>7</sup>

6.2.2.2 *Insertion Rod Guide*, AISI Type 316 tube, 6.4 mm ( $\frac{1}{4}$ in.) in outside diameter by 1.245 mm (0.049 in.) wall.

6.2.2.3 *Chamber Head* with 25.4 mm (1-in.) Corning ferrule.

6.2.2.4 *Pressure Transducer* (optional).

6.2.2.5 *Pressure Relief Valve*, capable of relieving pressure at 40 % above test equilibrium pressure.

6.2.2.6 *Air Inlet Valve*, AISI Type 316 stainless steel.

6.2.3 *Electromagnet*, capable of propelling insertion rod against anvil with sufficient force to break sample ampoule.

6.2.4 *Insertion Rod*, AISI Type 316 tubing, 3.2 mm ( $\frac{1}{8}$ in.) in outside diameter by 673 mm (26.5 in.) in length with attached armature.

6.2.5 *Flange Assembly*, Corning Style 1 for 25.4 mm (1-in.) pipe.

6.2.6 *Thermocouples*, calibrated precision grade iron-constantan (ISA-Type and Chromel-Alumel (ISA-Type K), Awg No. 30 glass-fiber insulated, bare-junction (welded) in 5-mm borosilicate glass tube.

<sup>6</sup> Apparatus obtained from W.A. Sales Ltd., 419 Harvester Ct., Wheeling, IL 60090 has been found satisfactory.

<sup>7</sup> Reducer, Swagelok 200-R-4-316BT with silicone rubber disk insert to form seal around wire has been found satisfactory.

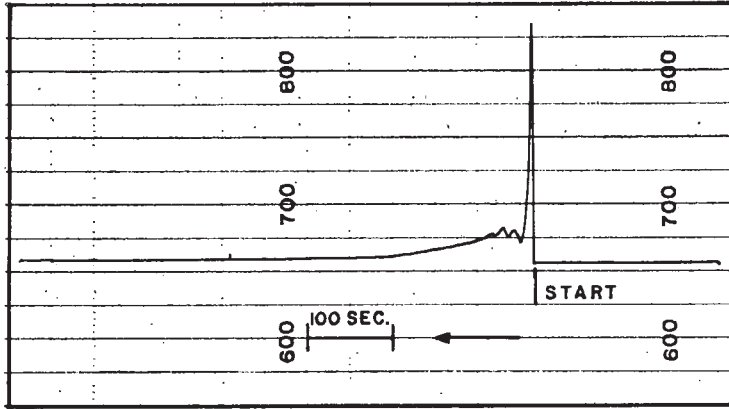

FIG. 5 Time-Temperature Profile and Delay Time for Typical Hot-Flame Reactions

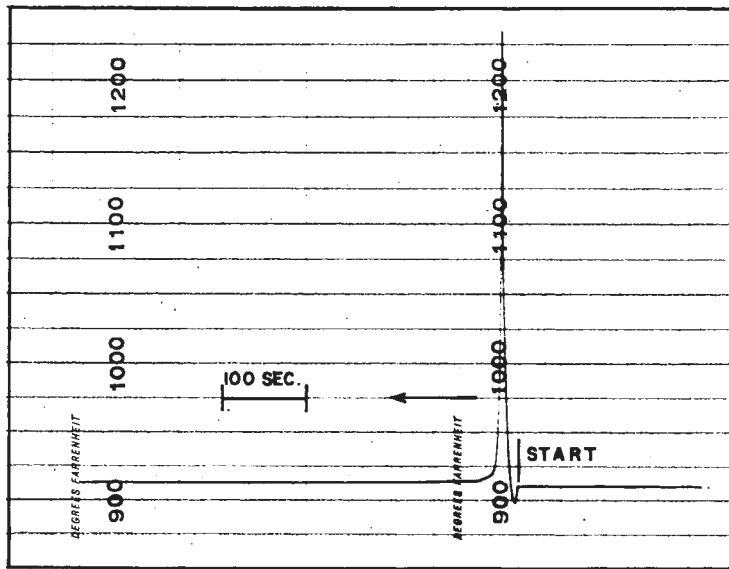

FIG. 6 Time-Temperature Profile and Delay Time for Typical Hot-Flame Reactions

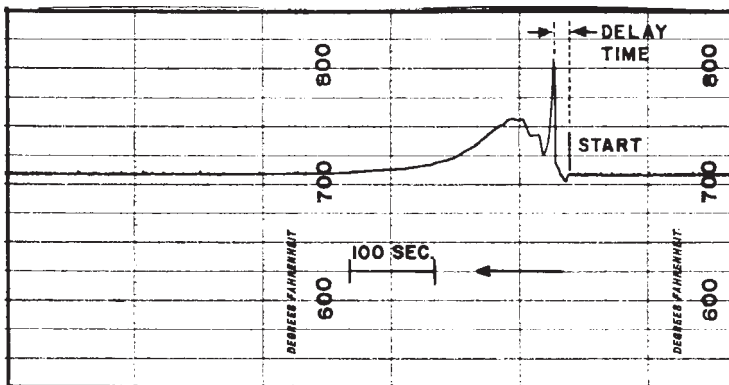

FIG. 7 Time-Temperature Profile and Delay Time for Typical Hot-Flame Reactions

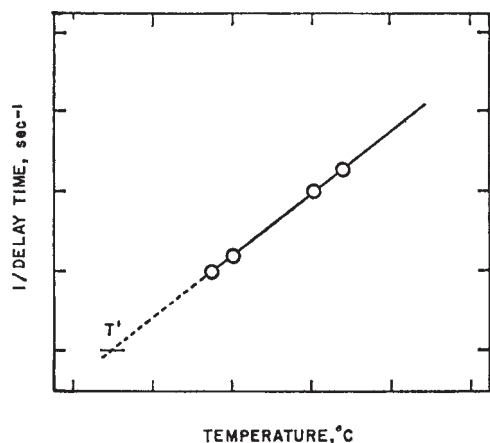

FIG. 8 Effect of the Reaction Temperature on the Delay Time to Determine Incipient Reaction Temperature

6.3 *Sample Ampoule*, illustrated for solids and liquids in Fig. 14.

6.4 *Temperature Recorder*,<sup>8</sup> 475 to 1025 K, (400 to 1400°F) range, ¼ s full-scale deflection, thermocouple actuation with range changes for iron-constantan and Chromel-Alumel elements.

6.5 *Hypodermic Syringe*,<sup>9</sup> fluorocarbon-tipped 0.5 mL and 2.5 mL with hypodermic needles suitable for introduction into sample ampoules.

6.6 *Pressure Gages*, capable of determining the appropriate pressure with an accuracy of ±1 %.

6.7 *Vacuum System*, capable of attaining and maintaining the required pressure with mechanical vacuum pump<sup>10</sup> and cold trap inserted in the line between the reaction temperature apparatus and the pump.

6.8 *Gas Supply System*,<sup>11</sup> capable of supplying the appropriate gas, dewpoint 215 K (−70°F) maximum and essentially free of contaminants at pressures up to 0.8 MPa. (**Warning**—Compressed gas under high pressure. Gas reduces oxygen available for breathing. See A2.1.)

6.9 *Exhaust Hood*, capable of disposing of fumes vented from the reaction temperature apparatus.

## 7. Reagents and Materials

7.1 *Trichloroethylene*, conforming to MIL-T-7003. Trichlorotrifluoroethane conforming to MIL-C-81302 or high flash point naphtha may be used as alternatives. (**Warning**—Harmful if inhaled. High concentrations may cause unconsciousness or death. Contact can cause skin irritation and dermatitis. See A2.2.)

7.2 *Cleaning Compounds*.<sup>12</sup>

7.3 *Chloroform*, technical grade. (**Warning**—Can be fatal if swallowed. Harmful if inhaled. Can produce toxic vapors if burned. See A2.5.)

7.4 *Detergent*, free-rinsing, conforming to Specification D 2021.

7.5 *Reagent Water*, conforming to Specification D 1193, either grade.

7.6 *Acetic Acid*, ACS reagent grade.

7.7 *Hydroiodic Acid*, 57 % reagent grade.

## 8. Test Specimen

8.1 *Liquid Sample*—200 mL is sufficient for the determination of the various reaction threshold temperatures at a single pressure.

8.2 *Solid Sample*—150 g is sufficient for the determination of the various reaction threshold temperatures at a single pressure.

## 9. Procedure

9.1 *Method A for Liquids*:

9.1.1 Clean a combustion chamber as follows: rinse with trichloroethylene (**Warning**—Harmful if inhaled. High concentrations may cause unconsciousness or death. Contact can cause skin irritation and dermatitis. See A2.2.), immerse in cleaning compound for a minimum of 15 min at 293 to 308 K, wash with detergent, and rinse thoroughly with reagent water. Dry in an oven at 393 to 423 K. Discard the chamber if not free of deposits. Clean the thermocouple internal supports, anvil, and insertion rod in the same manner.

NOTE 2—A chloroform (see 7.3) rinse prior to washing can prove useful in some cases. Difficult deposits may be removed by walnut shell abrasion. Discard the chamber if deposits can not be removed or if inspection reveals that the interior of the chamber has been damaged or corroded.

NOTE 3—Stainless steel, Type 316 combustion chambers and an air atmosphere have been specified with this test method. However, chambers of other materials and of different sizes, and atmospheres of other gases may be used when required.

NOTE 4—Chambers may be tested for the presence of peroxide or free radical residues by purging them with nitrogen and rinsing with a freshly prepared mixture of 3 mL each of chloroform, glacial acetic acid, (**Warning**—Poison. Corrosive. Combustible. Can be fatal if swallowed. Causes severe burns. Harmful if inhaled. See A2.6) and hydroiodic acid (57 % analytical grade, not stabilized) (**Warning**—Poison. Corrosive. Can be fatal if swallowed. Liquid and vapor cause severe burns. Harmful if inhaled. See A2.7). When this mixture is poured into a clean glass vessel and 10 drops of stabilized starch solution added, a trace of the starch-iodine color reaction indicates no peroxides or free radicals are present.

9.1.2 Assemble the reaction temperature apparatus in accordance with Fig. 11, using a clean combustion chamber. Insert the assembly horizontally in the oven to the middle of the temperature-controlled zone to a minimum inside depth of 21 cm.

9.1.3 Connect the vacuum system, gas supply system (**Warning**—Compressed gas under high pressure. Gas reduces oxygen available for breathing. See A2.1.), pressure gages, and temperature recorder to the apparatus in accordance with Fig. 13.

9.1.4 Set the temperature controller of the oven at a temperature approximately 50 K below the expected threshold for

<sup>8</sup> Honeywell Model KSY 153 × 116—(PH)-II-III-163-66-D has been found satisfactory.

<sup>9</sup> Hamilton Co., Whittier, CA, Models 1750 and 1002 with Luer Lok, have been found satisfactory.

<sup>10</sup> A 125 W (½ hp) carbon vane pump has been found satisfactory for most applications.

<sup>11</sup> Dry air produced by Matheson Co., East Rutherford, NJ, has been found satisfactory.

<sup>12</sup> “Transpo” cleaner manufactured by Turco Products, Inc., Rockdale, IL, has been found satisfactory.

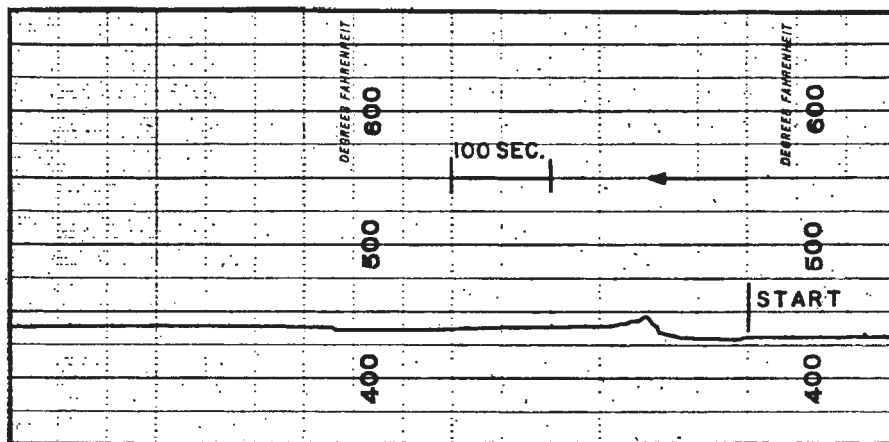

FIG. 9 Time-Temperature Profile for Typical Pre-Flame Reactions

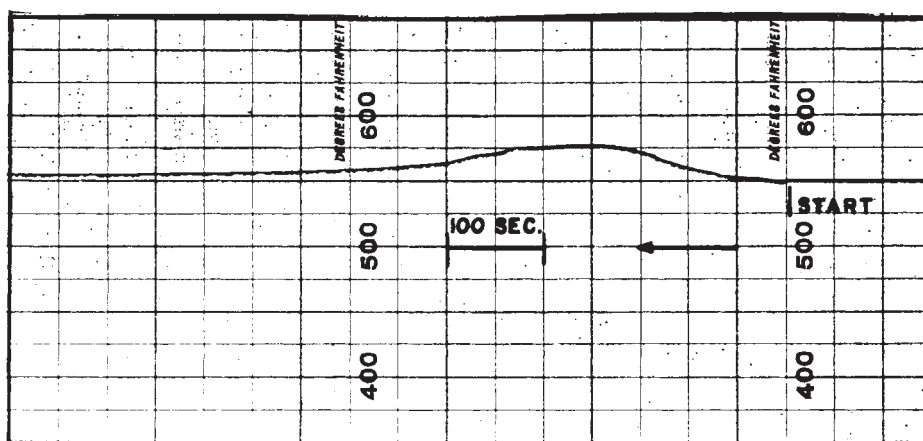

FIG. 10 Time-Temperature Profile for Typical Pre-Flame Reactions

the hot-flame reaction of the sample. Turn on the heat and blower switches of the oven. Increase the pressure in the gas supply system or decrease the pressure through the vacuum system as required.

9.1.5 Establish thermal and pressure equilibrium in the system. Record the temperature and pressure for at least 10 min to ensure a satisfactory equilibrium.

9.1.6 Fill the 0.5-mL syringe with a portion of the sample and transfer 0.2 mL to the thin-walled bulb portion of the liquid sample ampoule (Fig. 14). Place the cap on the ampoule and affix the covered ampoule to the end of the insertion rod.

9.1.6.1 If the sample is extremely volatile, seal the ampoule by drawing the open end closed in the flame of a torch. Use caution to prevent possible violent reaction between sample and flame.

9.1.6.2 Sample volatility is evaluated by placing a filled, weighed ampoule in the combustion chamber head with the system at test temperature and pressure for 10 min. A weight loss from the ampoule greater than 10 % after exposure indicates that the volatility is sufficiently great to require sealing.

9.1.7 Open the air inlet valve and allow the combustion chamber to attain atmospheric pressure. Remove the seal cap

on the insertion rod guide and place the ampoule-insertion rod inside the guide. Replace the seal cap.

9.1.8 Reestablish the temperature and pressure of the system at the appropriate level and record the temperature and pressure for at least 10 min to reaffirm that the system is free of leaks.

9.1.9 Activate the electromagnet and rapidly move the magnet forward to drive the insertion rod into the furnace and smash the ampoule against the anvil affixed to the thermocouple support. Mark the start of test on the recorder. Withdraw the insertion rod with magnet immediately after the sample has been delivered. Perform this entire operation as quickly as possible (no longer than 4 s).

9.1.10 Continue to record the temperature and other reaction parameters of the combustion chamber for a minimum of 10 min after sample introduction or until there is no evidence of continuing reaction within the system. Record the initial equilibrium temperature as the test temperature.

9.1.10.1 Reactions are detected by the evolution of heat that increases the temperature or pressure, etc., of the combustion chamber in a characteristic manner depending on the type of reaction. The measurement of temperature is presently the

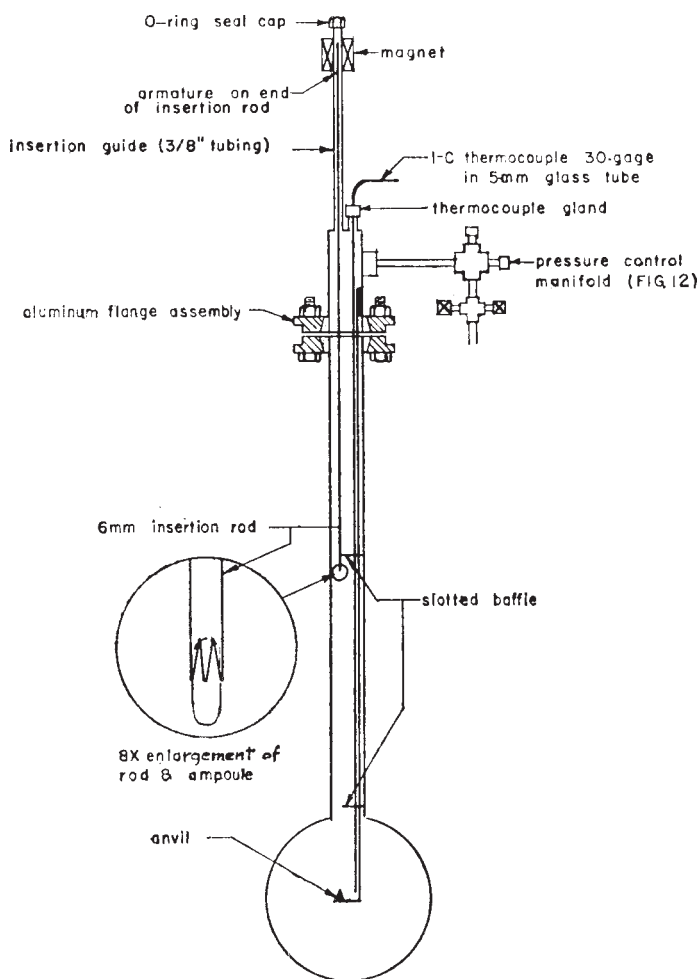

FIG. 11 Reaction Temperature Apparatus-Detail Assembly of Reaction Vessel

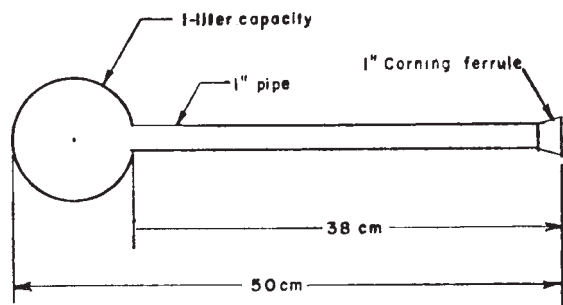

FIG. 12 Combustion Chamber

principal method for following the reactions of the sample. A pressure transducer, optical device, or other suitable detectors may also be used.

9.1.10.2 Occasionally a sample reacts catalytically with the thermocouple elements. Such a reaction causes an extraordinarily large and enduring exothermic heat effect. In such cases, it is necessary to change the thermocouple element. Usually, Chromel-Alumel and iron-constantan will not both have catalytic activity towards a single material.

9.1.11 Upon completion of a test, open the air inlet valve and release the gases into an exhaust hood. Disconnect the combustion chamber from the reaction apparatus and remove from the furnace.

NOTE 5—The products of the thermal or oxidative degradation of many materials are toxic. Although the exhaust hood is usually sufficient, special protective measures, that is, gas masks, can sometimes be necessary to protect the operator.

9.1.12 If the record shows that a hot-flame reaction has not occurred in 9.1.10, make an additional test in accordance with 9.1.1 through 9.1.11 at 50 K higher temperature, and continue to increase the chamber temperature by increments of 50 K until a hot-flame reaction is observed. Repeat tests at intermediate temperatures until the threshold for the hot-flame reaction has been determined to within 3 K. Record the lowest temperature of reaction as the hot-flame reaction temperature,  $T_h$ .

9.1.13 Repeat the procedure described in 9.1.1 through 9.1.12 using a 0.1-mL sample.

9.1.14 If the hot-flame reaction temperature,  $T_h$ , determined in 9.1.13 is lower than the corresponding one found in 9.1.12, repeat the procedure of 9.1.1 through 9.1.12 for a 0.05-mL sample. If the threshold value is higher, repeat the procedure of 9.1.1 through 9.1.12 for a 0.5-mL sample.

9.1.15 If the procedure performed in 9.1.12 through 9.1.14 does not provide sufficient data to determine the minimum value of the hot-flame reaction as a function of temperature, perform additional tests with smaller or larger samples as required.

NOTE 6—The standard liquid ampoule will not contain a sample larger than 0.5 mL or 500 mg. If required, a larger ampoule is constructed by increasing the length of the ampoule in Fig. 13.

9.1.16 If the incipient hot-flame reaction temperature,  $T'_h$ , is required, use the volume from 9.1.12 through 9.1.15 that resulted in the lowest temperature for a hot-flame reaction and make tests at 10 K temperature intervals until at least four data points are observed for hot-flame reactions that have delay times greater than 5 s.

9.1.17 If required, cool-flame or pre-flame reaction temperatures,  $T_c$  or  $T_p$ , are determined by application of the method of 9.1.1 through 9.1.16. The distinction between pre-flame and cool-flame is often difficult because the transition may be very gradual.

NOTE 7—The complete study of a material requires the determination of the various threshold values as functions of sample size. When a complete study is not required, a 0.2 mL liquid or 200 mg solid sample is used. In most cases, the pre-flame reaction temperature obtained for the 0.2-mL or 200-mg sample series will not differ substantially from the threshold temperature.

9.2 Method B for Solids—The procedure for solid samples is the same as that described in 9.1.1 through 9.1.17 except that,

9.2.1 The solid sample ampoule in Fig. 14 is used,

9.2.2 A sample size of 200 mg is used for initial determinations,

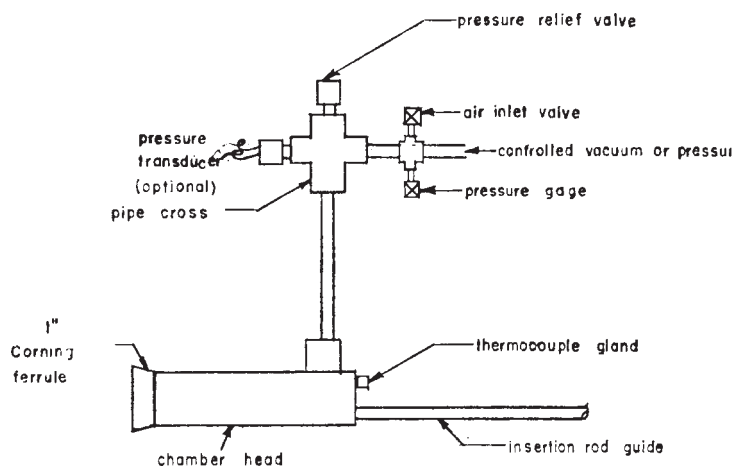

FIG. 13 Pressure Control Manifold and Accessories for Complete Assembly of Apparatus

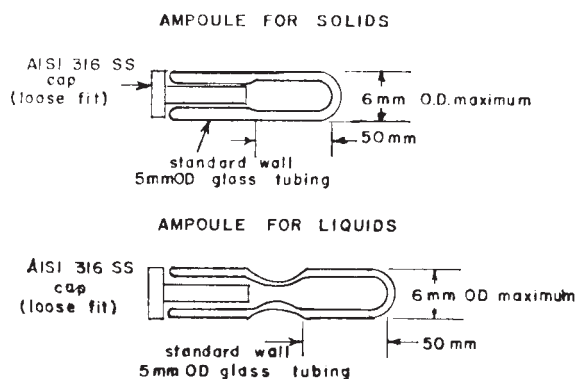

FIG. 14 Standard Sample Ampoules

9.2.3 Successive determinations with a 100-mg sample, and 50-mg or 500-mg samples shall then be run in accordance with 9.1.13 through 9.1.16.

## 10. Calculation

10.1 *Hot-Flame Reaction Threshold Temperature*—Plot the hot-flame reaction temperature,  $T_h$ , versus the sample size as in Fig. 15. The minimum temperature of this plot is the hot-flame reaction threshold temperature of the material at the pressure,  $P$ , at which the data were taken.

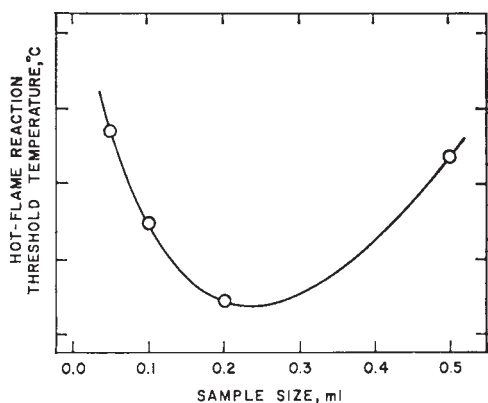

FIG. 15 Minimum Hot-Flame Reaction Threshold Temperature

10.2 *Cool-Flame Reaction Threshold Temperature*—Plot the cool-flame reaction temperature,  $T_c$ , versus the sample size. The minimum temperature of this plot is the cool-flame reaction threshold temperature.

10.3 *Pre-Flame Reaction Threshold Temperature*—Plot the pre-flame reaction temperature,  $T_p$ , versus the sample size. The minimum temperature of this plot is the pre-flame reaction threshold temperature.

10.4 *Incipient Hot-Flame Temperature,  $T'_h$* —Measure the delay time,  $t$ , of the hot-flame reaction from the time-temperature and time-pressure records (optional), determined in accordance with 9.1.16. Plot the reciprocal of the delay time ( $t^{-1}$ ) versus the hot-flame reaction temperature,  $T_h$ . Extrapolate the plot to infinite delay time,  $t^{-1} = 0$  illustrated in Fig. 9. The extrapolated temperature is the incipient hot-flame temperature,  $T'_h$ .

10.4.1 In some cases, the relationship between delay time and the reaction temperature cannot be extrapolated and no incipient temperature can be determined. This situation commonly occurs when synthetic materials are tested.

10.5 *Incipient Cool-Flame Temperature,  $T'_c$* —Measure the delay time,  $t$ , of the cool-flame reaction from the time-temperature and time-pressure records (optional), determined in accordance with 9.1.17. Plot the reciprocal of the delay time ( $t^{-1}$ ) versus the cool-flame reaction temperature,  $T_c$ . Extrapolate the plot to infinite delay time,  $t^{-1} = 0$ . The extrapolated temperature is the incipient cool-flame temperature,  $T'_c$ .

## 11. Report

11.1 The hot-flame reaction threshold temperature shall be reported, and the following data included:

- 11.1.1 Test atmosphere, if not air,
- 11.1.2 Test pressure,  $P$ ,
- 11.1.3 Combustion chamber material, if not AISI Type 316,
- 11.1.4 Combustion chamber size and shape, if not 1000-mL round-bottom,
- 11.1.5 Thermocouple used,
- 11.1.6 Readout method—temperature, pressure or other,
- 11.1.7 Unusual reactions occurring during tests, that is  $T_n$ ,  $T_c$ , and
- 11.1.8 Test variations, that is, sample size nonconforming.



## 12. Precision and Bias

12.1 *Precision*—Because of the complex nature of this test method for reaction threshold temperature of liquid and solid materials, there is not a sufficient number of volunteers to permit a cooperative laboratory program for determining the precision. If the necessary volunteers can be obtained, a program will be undertaken at a later date.

12.2 *Bias*—No statement is made about the bias of the test method since the results cannot be compared to an accepted reference material.

## 13. Keywords

13.1 cool-flame reaction; hot-flame reaction; incipient reaction; pre-flame reaction; reaction threshold temperature

## ANNEXES

### (Mandatory Information)

#### A1. TYPICAL REACTION TEMPERATURE OVEN

A1.1 *Tray-Type Electric Bench Oven*,<sup>13</sup> 923 K maximum operating temperature, 10-kW input in one zone for direct operations of 220 V, 1 phase, 60-Hz power supply, effective oven working dimensions 457 mm wide by 432 mm deep by 457 mm high. Fig. A1.1 shows various features. The oven includes the following:

A1.1.1 Centrifugal oven atmosphere recirculating blower with 190 W (¼-hp) fan motor.

A1.1.2 15-cm walls including insulation and stainless steel interior.

A1.1.3 Temperature controller,<sup>14</sup> for use with Chromel-Alumel thermocouple.

<sup>13</sup> Heavi-Duty Heating Equipment Division, Basic Products Corp., Watertown, WI, Model BTE-12-181818, modified for this test method.

<sup>14</sup> Wheelco Instruments Div., Barber-Colman Co., Rockford, IL, Model No. 152, is satisfactory.

A1.1.4 *On-off* heat switch.

A1.1.5 Blower control switch.

A1.1.6 Indicating pilot lights on blower and heater.

A1.1.7 Adjustable fresh air intake for fast cooling, purging, or exhausting work space.

A1.1.8 Overload protected.

A1.1.9 Three-position heat switch for high-medium-low operation.

A1.1.10 Lined lead-in port in center of door.

A1.1.11 Lined lead-in port in side of wall of oven, 5-cm diameter.

A1.1.12 Double-pane viewing window, 152 by 152 mm oven door.

A1.1.13 Radiation shield on rear inner wall of oven.

A1.1.14 Stainless steel angle support bracket with drilled holes.

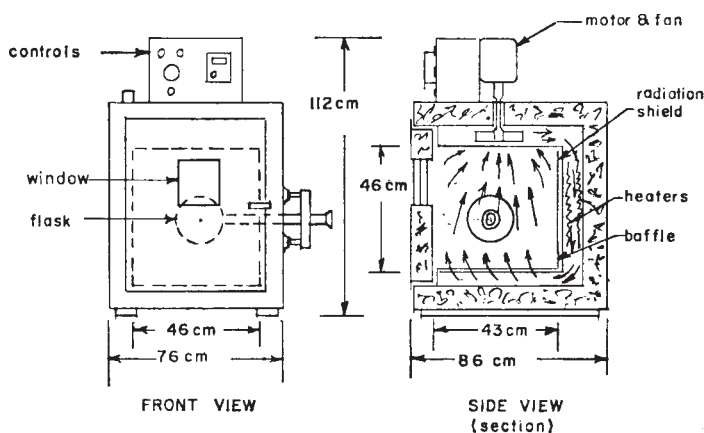

FIG. A1.1 Reaction Temperature Oven

## A2. PRECAUTIONARY STATEMENTS

### A2.1 Compressed Gas

**Warning**—Compressed gas under high pressure. Gas reduces oxygen available for breathing.

Keep cylinder valve closed when not in use.

Use with adequate ventilation.

Do not enter storage areas unless adequately ventilated.

Always use a pressure regulator. Release regulator tension before opening cylinder.

Do not transfer to cylinder other than one in which gas is received.

Do not mix gases in cylinders.

Never drop cylinder. Make sure cylinder is supported at all times.

Stand away from cylinder outlet when opening cylinder valve.

Keep cylinder out of sun and away from heat.

Keep cylinder from corrosive environment.

Do not use cylinder without label.

Do not use dented or damaged cylinders.

For technical use only. Do not use for inhalation purposes.

### A2.2 Trichloroethylene

**Warning**—Harmful if inhaled. High concentrations may cause unconsciousness or death. Contact can cause skin irritation and dermatitis.

Avoid prolonged or repeated breathing of vapor or spray mist.

Use only with adequate ventilation.

Eye irritation and dizziness are indications of overexposure.

Do not take internally. Swallowing may cause injury, illness or death.

Avoid prolonged or repeated contact with skin.

Do not get in eyes.

Can produce toxic vapors on contact with open flames, hot glowing surfaces or electric arcs.

### A2.3 Trichlorotrifluoroethane

**Warning**—Inhalation of high concentrations can cause anaesthetic effects or asphyxiation. Repeated or prolonged skin contact will cause defatting and possible dermatitis. Can produce toxic vapors if burned.

Use with adequate ventilation.

Keep container closed.

Avoid prolonged breathing of vapor or spray mist.

Avoid prolonged or repeated contact with skin.

Can produce toxic vapors on contact with flames, hot glowing surfaces or electric arcs.

### A2.4 Naphtha and Naphtha for Grease Analysis (flash point over 311 K (100°F))

Tag closed cup flash point over 311 K (100°F).

**Warning**—Combustible. Vapor harmful.

Keep away from heat, sparks, and open flame.

Keep container closed.

Use with adequate ventilation.

Avoid breathing vapor or spray mist.

Avoid prolonged or repeated contact with skin.

### A2.5 Chloroform

**Warning**—Can be fatal if swallowed. Harmful if inhaled. May produce toxic vapors if burned.

Keep container closed.

Avoid prolonged breathing of vapor or spray mist.

Avoid contact with eyes and skin.

Do not take internally.

Use with adequate ventilation.

Can produce toxic vapors on contact with flames, hot glowing surfaces or electric arcs.

### A2.6 Acetic Acid (Glacial)

**Warning**—Poison. Corrosive. Combustible. Can be fatal if swallowed. Causes severe burns. Harmful if inhaled.

Do not get in eyes, on skin, or on clothing.

Do not breathe vapor, spray, or mist.

Dilute by addition of acid to water.

Keep away from heat and open flame.

Keep in tightly closed container in approved acid storage cabinet.

Keep cool.

Loosen closure carefully when opening.

Use with adequate ventilation.

Keep container closed when not in use.

Use protective clothing and goggles when handling.

Wash thoroughly after handling.

### A2.7 Hydroiodic Acid

**Warning**—Poison. Corrosive. Can be fatal if swallowed. Liquid and vapor cause severe burns. Harmful if inhaled.

Do not get in eyes, on skin, or on clothing.

Do not breathe vapor, spray, or mist.

Dilute by addition of acid to water.

Keep in tightly closed container in approved acid storage cabinet.

Keep cool.

Loosen closure carefully when opening.

Use with adequate ventilation.

Keep container closed when not in use.

Use protective clothing and goggles when handling.

Wash thoroughly after handling.

 **D 2883 – 95 (2000)<sup>e1</sup>**

*ASTM International takes no position respecting the validity of any patent rights asserted in connection with any item mentioned in this standard. Users of this standard are expressly advised that determination of the validity of any such patent rights, and the risk of infringement of such rights, are entirely their own responsibility.*

*This standard is subject to revision at any time by the responsible technical committee and must be reviewed every five years and if not revised, either reapproved or withdrawn. Your comments are invited either for revision of this standard or for additional standards and should be addressed to ASTM International Headquarters. Your comments will receive careful consideration at a meeting of the responsible technical committee, which you may attend. If you feel that your comments have not received a fair hearing you should make your views known to the ASTM Committee on Standards, at the address shown below.*

*This standard is copyrighted by ASTM International, 100 Barr Harbor Drive, PO Box C700, West Conshohocken, PA 19428-2959, United States. Individual reprints (single or multiple copies) of this standard may be obtained by contacting ASTM at the above address or at 610-832-9585 (phone), 610-832-9555 (fax), or [service@astm.org](mailto:service@astm.org) (e-mail); or through the ASTM website ([www.astm.org](http://www.astm.org)).*