



Standard Test Method for Sulfur in Liquefied Petroleum Gases (Oxy-Hydrogen Burner or Lamp)¹

This standard is issued under the fixed designation D 2784; the number immediately following the designation indicates the year of original adoption or, in the case of revision, the year of last revision. A number in parentheses indicates the year of last reapproval. A superscript epsilon (ϵ) indicates an editorial change since the last revision or reapproval.

^{ε1} NOTE—Warning notes were editorially moved into the standard text in July 2003.

1. Scope

1.1 This test method covers the determination of total sulfur in liquefied petroleum gases containing more than 1 $\mu\text{g/g}$. Specimens should not contain more than 100 $\mu\text{g/g}$ of halogens.

1.2 To attain the quantitative detectability that the method is capable of, stringent techniques must be employed and all possible sources of sulfur contamination must be eliminated. In particular, cleaning agents, such as common household detergents which contain sulfates, should be avoided.

1.3 The values stated in SI units are to be regarded as the standard. The values given in parentheses are for information only.

1.4 *This standard does not purport to address all of the safety concerns, if any, associated with its use. It is the responsibility of the user of this standard to establish appropriate safety and health practices and determine the applicability of regulatory limitations prior to use.*

2. Referenced Documents

2.1 ASTM Standards:

D 156 Test Method for Saybolt Color of Petroleum Products (Saybolt Chromometer Method)²

D 1193 Specification for Reagent Water³

D 1265 Practice for Sampling Liquefied Petroleum (LP) Gases (Manual Method)²

D 1266 Test Method for Sulfur in Petroleum Products (Lamp Method)²

D 1657 Test Method for Density or Relative Density of Light Hydrocarbons by Pressure Hydrometer²

E 11 Specification for Wire Cloth and Sieves for Testing Purposes⁴

¹ This test method is under the jurisdiction of ASTM Committee D02 on Petroleum Products and Lubricants and is the direct responsibility of Subcommittee D02.03 on Elemental Analysis.

Current edition approved May 10, 2003. Published July 2003. Originally approved in 1969. Last previous edition approved in 1998 as D 2784–98.

² *Annual Book of ASTM Standards*, Vol 05.01.

³ *Annual Book of ASTM Standards*, Vol 11.01.

⁴ *Annual Book of ASTM Standards*, Vol 14.02.

2.2 Institute of Petroleum Standard:⁵

IP 181 Sampling Petroleum Gases, Including Liquefied Petroleum Gases

3. Summary of Test Method

3.1 The sample is burned in an oxy-hydrogen burner, or in a lamp in a closed system in a carbon dioxide-oxygen atmosphere. The latter is not recommended for trace quantities of sulfur due to the inordinately long combustion times needed. The oxides of sulfur are absorbed and oxidized to sulfuric acid in a hydrogen peroxide solution. The sulfate ions are then determined by either of the following finishes:

3.1.1 *Barium Perchlorate Titration*—The sulfate is titrated with barium perchlorate using a thorin-methylene blue mixed indicator.

3.1.2 *Turbidimetric*—The sulfate is precipitated as barium sulfate and the turbidity of a suspension of the precipitate is measured with a photometer.

4. Significance and Use

4.1 It is important to have the sulfur content of liquefied petroleum gases at low enough concentration to meet government regulations. The presence of sulfur can result in corrosion of metal surfaces. Sulfur can be poisonous to catalysts in subsequent processing.

5. Apparatus

5.1 *Oxy-Hydrogen Combustion Assembly*—The two types listed below are recommended. Any combustion apparatus giving equivalent results, however, is satisfactory.

5.1.1 *Wickbold-Type Combustion Apparatus*, as shown in Fig. 1.

5.1.2 *Modified Beckman Burner-Type Apparatus*,^{6,7} as shown in Fig. 2. Each of the above types of apparatus shall

⁵ Available from American National Standards Institute (ANSI), 25 W. 43rd St., 4th Floor, New York, NY 10036.

⁶ The sole source of supply of the apparatus known to the committee at this time is Scientific Glassblowing Co., P.O. Box 18353, Houston, TX 77023.

⁷ If you are aware of alternative suppliers, please provide this information to ASTM International Headquarters. Your comments will receive careful consideration at a meeting of the responsible technical committee¹, which you may attend.

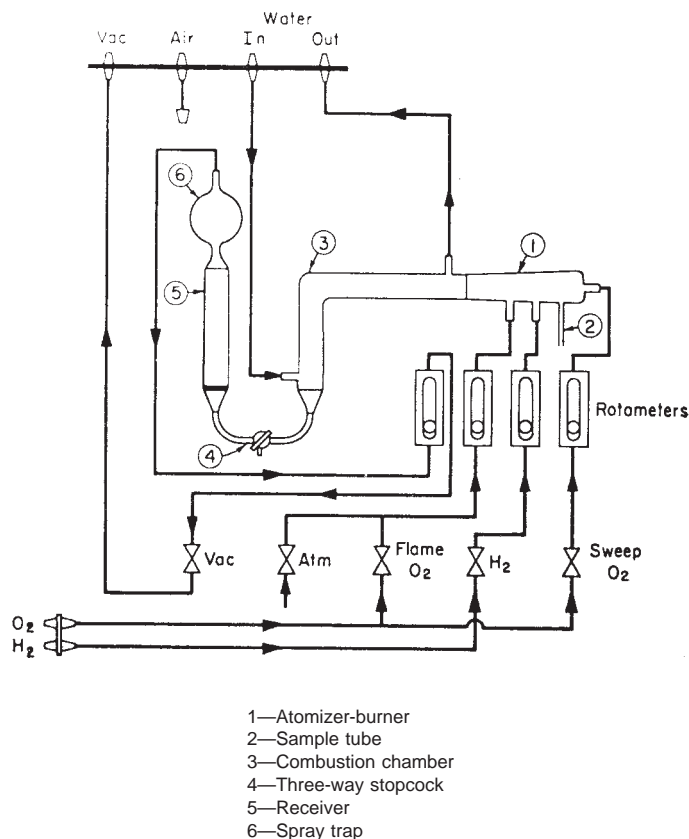

FIG. 1 Flow Diagram of a Typical Oxy-Hydrogen Combustion Apparatus

consist of three parts: atomizer-burner, combustion chamber, and absorber with spray trap. A blowout safety port in the combustion chamber is desirable. The remainder of the apparatus shall consist of a suitable support stand with the necessary needle valves and flow meters for precise control of oxygen, hydrogen, and vacuum.

5.1.3 *Safety Shield*—A transparent shield shall be used to protect the operator in the event an explosive mixture is formed in the combustion chamber.

5.2 *Apparatus for Lamp Combustion:*

5.2.1 *Absorbers, Chimneys, and Spray Traps*, as required are described in detail in Annex A3 of Test Method D 1266.

5.2.2 *Manifold System*, consisting of a vacuum manifold with regulating device, valves, etc. (Fig. 2 of Test Method D 1266) and a dual manifold (burner and chimney) supplying a gas mixture of approximately 70 % carbon dioxide (CO₂) and 30 % oxygen (O₂) at regulated pressures. The gas mixture in the chimney manifold shall be maintained at a nearly constant pressure of 1 to 2 cm of water and the burner manifold at approximately 20 cm of water. A suitable arrangement is shown in Fig. 2 of Test Method D 1266 and described in A3.6 of Annex A3 of Test Method D 1266, but any other similar system giving equivalent results can be used.

5.2.3 *Blast Type Gas Burner*, having dimensions given in Fig. 3.

5.3 *Vacuum Source*, having a capacity of at least 1200 L/h. If a vacuum pump is used, it should be protected by a suitable trap.

5.4 *Corrosion-Resistant Metal Cylinder, 75-mL*—It shall be tested at a pressure of 600 psig (4.14 MPa gage) and shall show no leaks when filled with air or nitrogen to this pressure and submerged in water. It shall be fitted with a needle valve for connection to the burner assembly.

5.5 *Variable Transformer, 0–120 V, 750-W.*

5.6 *Carbon Dioxide Pressure Regulator*— This regulator should be of a type that eliminates the refrigeration difficulties occurring with the pressure reduction of carbon dioxide.^{7,8}

6. Reagents and Materials

6.1 *Purity of Reagents*—Reagent grade chemicals shall be used in all tests. Unless otherwise indicated, it is intended that all reagents shall conform to the specifications of the Committee on Analytical Reagents of the American Chemical Society, where such specifications are available.⁹ Other grades may be used, provided it is first ascertained that the reagent is of sufficiently high purity to permit its use without lessening the accuracy of the determination.

6.2 *Purity of Water*—Unless otherwise indicated, references to water shall be understood to mean reagent water as defined by Types II or III of Specification D 1193. Water conforming to the following specification is required. Sulfate-free deionized water prepared by percolation of water through a column of mixed anion and cation exchange resins.

NOTE 1—A means for determining when to replace the exchange resins should be provided. Use of a simple electrical conductivity meter has been found satisfactory for this purpose.

6.3 *Standard Sulfate Solution (1 mL = 100 µg S)*—Dilute 6.24 ± 0.01 mL of 1 N sulfuric acid (H₂SO₄) with water to exactly 1 L. Check the dilution by titration against standard NaOH solution of about the same normality and adjust the concentration, if necessary, so that each millilitre of this solution is equivalent to 100 µg of sulfur.

6.4 *Hydrogen (Warning—Extremely flammable), Carbon Dioxide (Warning—Gas may reduce oxygen available for breathing), and Oxygen (Warning—Oxygen accelerates combustion)*, meeting the requirement in Note 12.

6.5 *Scavenger-Rinse*—Mix equal volumes of low-sulfur acetone and isopropanol.

6.6 *Hydrogen Peroxide Solution (1.5 %) (1 + 19)*—Mix 1 volume of concentrated hydrogen peroxide (H₂O₂ = 30 %) with 19 volumes of water. Store in a dark-colored, glass-stoppered bottle.

6.7 *Quality Control (QC) Sample(s)*, preferably are portions of one or more liquefied petroleum gas materials or product standards of known sulfur content that were not used in the generation of the instrument calibration curve. These (QC) samples are to be used to check the validity of the testing

⁸ The sole source of supply of the Victor Type SR 300 regulator known to the committee at this time is Victor Equipment Co., Controls Division, 2336 Auburn Blvd., Sacramento, CA 95821.

⁹ *Reagent Chemicals, American Chemical Society Specifications*, American Chemical Society, Washington, DC. For suggestions on the testing of reagents not listed by the American Chemical Society, see *Annual Standards for Laboratory Chemicals*, BDH Ltd., Poole, Dorset, U.K., and the *United States Pharmacopeia and National Formulary*, U.S. Pharmacopeial Convention, Inc. (USPC), Rockville, MD.

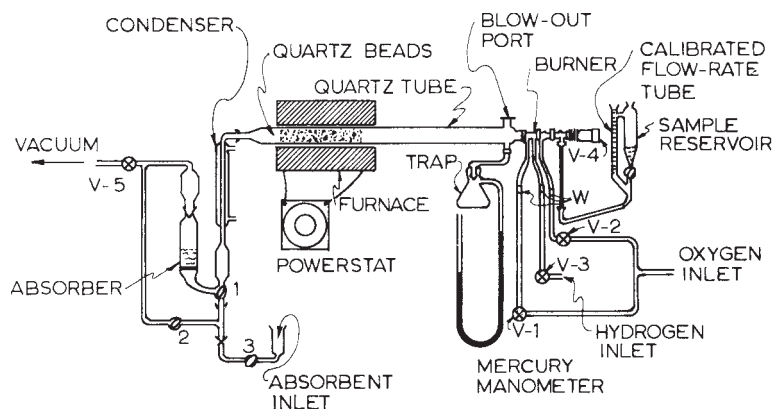
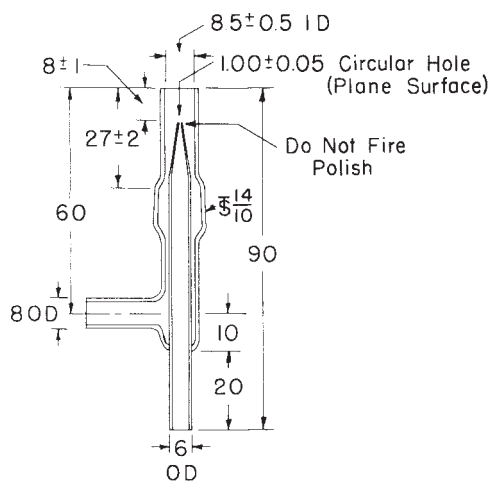

FIG. 2 Trace Sulfur Apparatus Flow Diagram



All dimensions in millimetres

FIG. 3 Blast-Type Gas Burner

NOTE 3—If the weight of liquefied petroleum gas is maintained below 45 g in a 75-mL container, the container cannot become full of liquid at room temperature.

8. Procedure for Combustion of Sample

8.1 Connect the sample cylinder with stainless steel tubing to the gas expansion valve. Attach to this another section of stainless steel tubing which runs to the vicinity of the burner. Make the final connection to the burner with sulfur-free rubber tubing. Wrap the expansion valve with heating tape and connect this to a variable transformer. Insert a thermometer between the heating tape and expansion valve so that the thermometer bulb is in contact with the valve body. See Fig. 4.

8.2 Turn on the variable transformer and allow the expansion valve to reach 43°C (110°F). Alternatively the expansion valve may be placed in a suitable metal beaker and covered with water maintained at 110°F.

8.3 *Oxy-Hydrogen Combustion*—Assemble the apparatus according to the manufacturer's directions (see also 14.1). Add to the absorber 25 mL of the hydrogen peroxide solution. (**Warning**—Before attempting subsequent operations, the operator should (1) be aware of the various hazards that can exist through the improper use of hydrogen as a fuel, and (2) have the safety shield in place.)

8.3.1 Light the burner and insert into the combustion chamber. If necessary, readjust gas flows. Open the bottom valve of the sample cylinder. Slowly open the expansion valve until an optimum burning rate is achieved.

8.4 *Lamp Combustion*—Add to the absorber 25 mL of hydrogen peroxide solution. Assemble the chimney, absorber, and spray trap and connect to the CO₂-O₂ and vacuum manifold. Make the necessary vacuum adjustments (see 5.1 of Test Method D 1266). Set up a control blank absorber as in 5.3 of Test Method D 1266.

8.4.1 Open the bottom valve of the sample cylinder. Slowly crack the gas expansion valve. Light the burner with an alcohol lamp, and insert the burner into the combustion chamber (chimney).

8.5 Burn a quantity of sample in accordance with Table 1.

NOTE 4—In burning materials with sulfur concentrations greater than 50 µg/g, restrict sample sizes to give quantities that will not contain more than 250 µg of sulfur for the turbidimetric finish or more than 150 µg for the barium perchlorate finish. Alternatively, aliquots of the absorber solutions which do not contain more than these maximums can be used.

process as described in Section 16. An ample supply of QC sample material shall be available for the intended period of use, and must be homogeneous and stable under the anticipated storage conditions.

7. Sampling Test Specimens and Test Units

7.1 Obtain the test unit in a container by the method conforming to the recommendations in Practice D 1265, or IP Method 181.

7.2 Evacuate a clean, dry 75-mL cylinder and weigh to the nearest 0.05 g. Connect the container to the inverted supply cylinder and introduce 24 to 40 g of the liquefied gas, taking care that the container does not become full of liquid. To prevent this, bleed off a small amount of the liquid phase of the material after filling but before reweighing. Reweigh the cylinder to 0.05 g.

NOTE 2—The 75-mL, corrosion-resistant metal vessel can be cleaned as follows: Remove the needle valve. Wash the interior of the vessel and valve, first with a sulfur-free hydrocarbon, such as *n*-pentane, and then wash with acetone. Dry the interior of the vessel with clean compressed air and rinse it with HCl (1 + 10). Rinse the interior with water until the wash water is neutral to a pH test paper. Wash the vessel with acetone and allow to drain at least 10 min. Dry the vessel with a stream of clean, compressed air and reassemble.

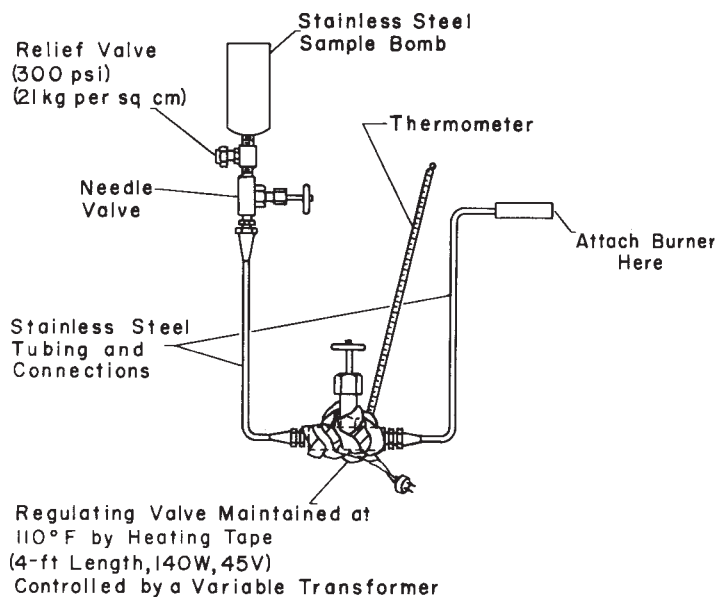

FIG. 4 Burner Assembly for LPG

TABLE 1 Sample Sizes

Sulfur Content, ppm	Sample Size, g	
	Turbidimetric Finish	Barium Perchlorate Finish
1 to 5	45	30
5 to 10	20	10
10 to 50	5	3

NOTE 5—Minor adjustment of the gas flow rates can be necessary to maintain those recommended by the manufacturer.

8.6 After a sufficient quantity of sample has been burned, turn the bottom valve of the cylinder off. Allow the remaining gas in the tubing and gas expansion valve to burn itself out. Turn the heat off on the gas expansion valve. Disconnect the tubing from the sample cylinder and reweigh the sample cylinder to the nearest 0.05 g. Leave the absorber solution in the assembled lamp unit. The same absorber solution will be used for the scavenger-rinse burning. Allow the expansion valve to cool to ambient temperature.

8.7 If the oxy-hydrogen burner permits, flush the tubing and valve with 10 mL of scavenger-rinse and burn without disconnecting the tubing. Otherwise disconnect the tubing and burn in the normal liquid mode. For the lamp burning collect the rinsings in a standard lamp sulfur (see Test Method D 1266) flask. Insert a standard burner equipped with a wick into the flask and carry out the combustion as described in Section 7 of Test Method D 1266.

8.8 For the oxy-hydrogen burners, when all of the rinsings are consumed, shut down the burner as recommended by the manufacturer.

8.9 After the rinsings have been burned in the lamp, remove it, turn off the CO₂-O₂ supply, and turn off the vacuum pump.

8.10 For oxy-hydrogen blank determinations burn a hydrocarbon stock with a very low or nondetectable sulfur content. Make at least two of these prior to the analysis of samples with trace sulfur contents to ensure that the blanks are small and constant. Subtract from the total sulfur figures any blank so obtained. The remainder is the net micrograms of sulfur from

the sample. Likewise subtract any sulfur obtained in the lamp combustion blank from the total figure.

8.11 Disconnect the spray trap from the vacuum line and thoroughly rinse the spray trap and chimney with about 35 mL of distilled water, collecting the rinsings in the absorber. It is important that any materials clinging to these parts be transferred to the absorber to avoid low values for sulfur content.

BARIUM PERCHLORATE TITRATION FINISH

9. Reagents

9.1 *Ion-Free Water*—Distill deionized water and store in tightly capped, high-density polyethylene bottles.

9.2 *Hydrochloric Acid, Standard Alcoholic (0.1 M)*—Dilute 20 mL of aqueous 0.5 M HCl with 80 mL of isopropanol.

9.3 *Inhibited Thorin-Methylene Blue Mixed Indicator Solution*—The indicator is made up as two solutions and these mixed together in equal volumes once per week as follows:

Solution A: 0.8 g thorin, (see^{7,10})
 0.29 g potassium bromate,
 water to make 500 mL,
 Solution B: 0.16 g methylene blue,
 0.2 mL of 0.5 M HCl,
 water to make 500 mL

9.4 *Fleisher's Methyl Purple Indicator Solution*.^{7,11}

9.5 *Barium Perchlorate (0.005 M)*—Dissolve 1.95 g of barium perchlorate trihydrate^{7,11} in 200 mL of water and add 800 mL of isopropanol. Adjust the apparent pH to about 3.5 with perchloric acid, using a pH meter.

9.6 *Perchloric Acid*,^{7,12} 70 %.

9.7 *Sodium Hydroxide, Standard Solutions (0.03 M)*—Prepare by mixing 7 parts of water with 3 parts of standard 0.1

¹⁰ The sole source of supply of the solution known to the committee at this time is Hach Chemical Co., Ames, IA.

¹¹ The sole source of supply of the solutions known to the committee at this time is Fleisher Chemical Co., Benjamin Franklin Station, Washington, DC 20044.

¹² The sole source of supply of perchloric acid known to the committee at this time is G. Frederick, Smith Chemical Co., P.O. Box 23344, Columbus, OH 43223.

M sodium hydroxide (NaOH) solution. Concentrate 400 mL of 0.03 *N* NaOH solution by evaporating to 30 mL, and determine any sulfate present in accordance with Appendix A1, Turbidimetric Procedure for Sulfate of Test Method D 1266. If sulfate is found, corrections must be made for any sulfur introduced by the reagent in the alkali titration following combustion.

9.8 Methylene Blue.

10. Preparation of Working Curve

10.1 Into separate 30-mL beakers pipet each of the aliquots of the standard sulfate solution given in Table 2. See 6.3. To each aliquot add sufficient water to make 3.4 mL, 12 mL of isopropanol (total volume 15.4 mL) and 3 drops of mixed thiorin-methylene blue indicator solution. Titrate as indicated below. For each sulfur level given in Table 2, titrate three of the corresponding aliquots. Plot the millilitres of titrant used versus micrograms of sulfur. Draw the best straight line through points. Check at least two points on the curved at least every 10 days.

11. Procedure for Analysis of Solutions

11.1 Quantitatively transfer the absorber contents to a 500-mL Erlenmeyer flask, using ion-free water for rinsing. Add 2 drops of Fleisher's methyl purple indicator solution to this solution and titrate to a faint green end point with 0.03 *M* NaOH solution (Note 7). Add 1 mL more of the 0.03 *M* NaOH solution to the solution and reduce the volume to 2 to 3 mL by evaporation on a hot plate in sulfate-free environment. (**Warning**—Do not boil.) DO NOT BOIL DRY. Cool the solution to room temperature and measure its volume in a 10-mL graduate (Note 7). Adjust the volume to 3.0 mL by adding ion-free water.

NOTE 6—The volume of sodium hydroxide should not exceed 2 mL. More indicates that the sulfur or halogen content is excessive or that there is a serious air leak in the apparatus.

NOTE 7—For high or completely unknown sulfur contents, the concentrated absorbent can be quantitatively transferred to a 5-mL volumetric flask, adjusted to 5 mL, and aliquots used. Each aliquot is then subsequently made up to 3 mL as in 11.1. Continue as in 11.2.

11.2 Transfer the absorbent to a 30-mL beaker, rinse the graduate and the 500-mL boiling flask successively with two 6-mL portions of isopropanol, and add the rinses to the beaker.

11.3 Pipet 0.40 mL of the standard sulfate solution (40 µg of sulfur) into the beaker. Add 2 drops of the thiorin-methylene blue mixed indicator solution. Adjust the resultant gray-green color by adding 0.1 *M* HCl dropwise to the solution until the color changes to bright green.

11.4 The 2-mL buret containing standard barium perchlorate should have its tip positioned just below the surface of the solution in the beaker. The solution must be stirred by a small bar on a magnetic stirrer or with a small propeller stirrer. A white background and good white light may be helpful in obtaining a precise end point. Add the barium reagent at a steady rate of 0.1 mL in 5 (±1) s until the end point is indicated

by a rapid, though slight, color change from green to a bluish gray (Note 8). Shut off the buret at the point of greatest rate of color change (Note 9).

NOTE 8—It is helpful to match end point colors with solutions saved from prior standardization titrations performed within the last 15 min and well stirred to prevent drop-out of the colored barium sulfate precipitate. People having a low red-green color sensitivity find that using the blue light of Test Method D 156, sharpens the end point very considerably.

NOTE 9—The end point can be checked by again adding 40 µg of sulfur (0.4 mL standard sulfuric acid) and retitrating to the end point.

11.5 From the working curve, find the total sulfur titrated to the nearest 1 µg. Subtract the 40 µg added.

11.6 For blank determinations, repeat the operations in 8.3 and 8.7, and burn a hydrocarbon stock with a very low or nondetectable sulfur content. Burn for the same length of time as the sample in the normal liquid mode. Subtract from the sulfur figures in 11.5 any blank so obtained. This is the net micrograms of sulfur from the sample.

TURBIDIMETRIC FINISH

12. Apparatus

12.1 *Photometer*—Preferably a spectrophotometer having an effective band width of about 50 nm, and equipped with a blue-sensitive phototube for use at 450 nm, or alternatively a filter photometer equipped with a color filter having a maximum transmission at approximately 450 nm.

12.2 *Absorption Cells*, having an optical path length of 5 cm. With use the cells may become coated with a film. To remove this film, wash the cells with a detergent, using a soft brush. After cleaning, rinse thoroughly with water.

NOTE 10—The procedure as written assumes an absorbance change of about 0.10 for each 100 µg of sulfur in 50 mL of solution measured in a 5-cm cell. Photometers employing cells of shorter optical paths will not give the precision of measurement stated in this method.

12.3 *Scoop*, capable of dispensing 0.30 ± 0.01 g of barium chloride dihydrate as specified in 13.2.

13. Reagents

13.1 *Alcohol-Glycerin Mixture*—Mix 2 volumes of denatured ethyl alcohol conforming to Formula No. 3A of the U.S. Bureau of Internal Revenue or ethyl alcohol (99 % by volume) with 1 volume of glycerin.

13.2 *Barium Chloride Dihydrate* ($\text{BaCl}_2 \cdot 2\text{H}_2\text{O}$)—Crystals passing a 20-mesh (850-µm) sieve and retained on a 30-mesh (600-µm) sieve conforming to Specification E 11.

NOTE 11—The crystal size of the $\text{BaCl}_2 \cdot 2\text{H}_2\text{O}$ is an important variable that affects the development of turbidity.

13.3 *Hydrochloric Acid* (1 + 12)—Add 77 mL of concentrated hydrochloric acid (HCl, relative density 1.19) to a 1-L volumetric flask and dilute to the mark with water.

14. Calibration

14.1 Only by the most scrupulous care and attention to details can reliable results be obtained by this method. Before using new glassware and thereafter as required, clean the glassware with concentrated nitric acid. Rinse three times with

TABLE 2 Preparation of Working Curve

Sulfur, µg	40	80	120	240	300
Aliquots, mL	0.40	0.80	1.20	2.40	3.00

tap water and follow with three rinses of deionized water. Reserve the glassware for use in this method alone.

14.2 Into 50-mL volumetric flasks introduce, by means of the buret, 0.25, 0.50, 0.75, 1.00, 1.50, 2.00, 3.00, and 5.00 mL of standard sulfate solution (1 mL = 100 µg S). See 6.3. Add 3.0 mL of HCl (1 + 12) to each flask, dilute to volume with water, and mix thoroughly. Prepare a reagent blank standard in a similar way, omitting the standard sulfate.

14.3 Pour the entire contents of each flask into a 100-mL beaker. Add by means of a pipet 10 ± 0.1 mL of alcohol-glycerin mixture and mix for 3 min on the magnetic stirrer. Select a stirring speed just below that which might cause loss of sample through splashing. Maintain this speed throughout the entire procedure.

14.4 Allow the solution to stand undisturbed for 4 min. Transfer to an absorption cell and measure the initial absorbance, using water as reference.

14.5 Return the solution to the beaker and add 0.30 ± 0.01 g of $\text{BaCl}_2 \cdot 2\text{H}_2\text{O}$ crystals, either by weighing this amount or by using the scoop. Stir with the magnetic stirrer for exactly 3 min. Allow to stand for an additional 4 min, transfer to the cell, and again measure the absorbance relative to water.

14.6 Following steps described in 14.3, 14.4, and 14.5, obtain a reagent blank reading by subtracting the initial absorbance of the reagent blank standard from that obtained after addition of $\text{BaCl}_2 \cdot 2\text{H}_2\text{O}$. This reading should not exceed 0.005.

14.7 Obtain the net absorbance for each standard by subtracting the initial absorbance and reagent blank reading from the absorbance obtained in accordance with 14.5. Plot the net absorbance of each standard against micrograms of sulfur contained in 50 mL of solution and draw a smooth curve through the points.

14.8 To detect possible shifts, check the calibration curve daily by making single determinations.

15. Procedure for Analysis of Absorber Solutions

15.1 Drain the absorber solution into a 250-mL beaker and quantitatively rinse the absorber collecting the rinsings in the beaker.

15.2 Reduce the volume of the absorber solutions to about 25 mL by evaporation on a hot plate. Quantitatively transfer the resultant solution to a 50-mL volumetric flask, rinsing the beaker with several small portions of water. Add 3 mL of HCl (1 + 12) to the flask, make up to volume with water, and mix thoroughly.

15.3 Into a 100-mL beaker pour the entire contents of the 50-mL volumetric flask containing the solution to be analyzed. Proceed as directed in 14.3, 14.4, and 14.5.

NOTE 12—Should the blank reading exceed 0.020, the precision obtainable will be impaired. If so, make an analysis of the reagents alone to determine whether the atmosphere or reagents are at fault. Place 30 mL of the H_2O_2 (1.5 %) in the 50-mL volumetric flask, dilute to the mark with HCl (1 + 215), and proceed as described in 14.6. If this reagent blank reading exceeds 0.010, results should not be considered reliable.

15.4 Obtain the net absorbance of the analysis solution by subtracting the initial absorbance and the net absorbance for the oxy-hydrogen combustion blank or the lamp combustion

(depending upon the apparatus used for combustion) from that obtained after the addition of $\text{BaCl}_2 \cdot 2\text{H}_2\text{O}$.

15.5 Convert net absorbance to micrograms of sulfur by using the calibration curve.

16. Calculation

16.1 Calculate the amount of sulfur in the sample as follows:

$$\text{Sulfur content, } \mu\text{g/g} = A/W \quad (1)$$

where:

A = micrograms of sulfur as obtained in 11.6 or 15.5, and

W = grams of sample burned.

16.1.1 Round the result of the test to the nearest 1 µg/g of sulfur.

16.2 Alternatively calculate the concentration in units of grains of total sulfur per 100 ft³ as follows:

$$R \text{ (for propane)} = 0.083S \quad (2)$$

$$R \text{ (for butane)} = 0.111S$$

$$R \text{ (for propane-butane mixtures)}$$

$$= S [0.366(G - 0.5077) + 0.083]$$

where:

R = grains of total sulfur per 100 ft³ of gas at 15.6°C (60°F) and 0.10132 MPa (760 mm) Hg,

S = sulfur content, µg/g, and

G = relative density of the mixture at 15.6/15.6°C (60/60°F).

NOTE 13—The derivatives of constants used in the above equations are based on the following properties of propane and butane:

Specific volume for propane (of the real gas at 60°F and 14.696 psig), ft ³ /lb of gas	8.4515
Specific volume for butane (same conditions as above)	6.3120

NOTE 14—If the relative density of the mixture is not known, determine it by Test Method D 1657.

NOTE 15—Multiply by 2.2883 to convert grains per cubic foot to grams per cubic metre. Multiply by 35.31 to convert grains per cubic metres to grams per cubic feet.

17. Quality Control

17.1 Confirm the performance of the apparatus or the procedure, or both, each day it is in use by analyzing a QC sample (6.7) that is representative of samples typically analyzed. Analysis of the result(s) from the QC sample(s) can be carried out using control charts,¹³ or other statistically equivalent techniques, to ascertain the control status of the total testing process. Any out of control data should trigger investigation for root cause. The QC sample precision shall be checked against the ASTM method precision to ensure data quality.

18. Precision and Bias

18.1 The precision of this test method has not been determined. The responsible subcommittee is attempting to attract volunteers for an interlaboratory study.

¹³ ASTM Manual 7, *Manual on Presentation of Data and Control Chart Analysis*, ASTM International, W. Conshohocken.

18.2 The bias of this test method cannot be determined since appropriate reference material containing a known level of sulfur in liquefied petroleum gases is not available.

19. Keywords

19.1 lamp; liquefied petroleum gas; oxy-hydrogen burner; sulfur

ASTM International takes no position respecting the validity of any patent rights asserted in connection with any item mentioned in this standard. Users of this standard are expressly advised that determination of the validity of any such patent rights, and the risk of infringement of such rights, are entirely their own responsibility.

This standard is subject to revision at any time by the responsible technical committee and must be reviewed every five years and if not revised, either reapproved or withdrawn. Your comments are invited either for revision of this standard or for additional standards and should be addressed to ASTM International Headquarters. Your comments will receive careful consideration at a meeting of the responsible technical committee, which you may attend. If you feel that your comments have not received a fair hearing you should make your views known to the ASTM Committee on Standards, at the address shown below.

This standard is copyrighted by ASTM International, 100 Barr Harbor Drive, PO Box C700, West Conshohocken, PA 19428-2959, United States. Individual reprints (single or multiple copies) of this standard may be obtained by contacting ASTM at the above address or at 610-832-9585 (phone), 610-832-9555 (fax), or service@astm.org (e-mail); or through the ASTM website (www.astm.org).