



Standard Test Method for Engine Coolants by Engine Dynamometer¹

This standard is issued under the fixed designation D 2758; the number immediately following the designation indicates the year of original adoption or, in the case of revision, the year of last revision. A number in parentheses indicates the year of last reapproval. A superscript epsilon (ϵ) indicates an editorial change since the last revision or reapproval.

^{ε1} NOTE—Editorial corrections were made in April 1998.

1. Scope

1.1 This test method covers a full-scale clean engine test designed to evaluate corrosion protection and inhibitor stability of engine coolants under simulated heavy-duty driving conditions.

1.2 The values stated in SI units are to be regarded as the standard. The values given in parentheses are for information only.

1.3 *This standard does not purport to address all of the safety concerns, if any, associated with its use. It is the responsibility of the user of this standard to establish appropriate safety and health practices and determine the applicability of regulatory limitations prior to use.* Specific hazards statements are given in Section 6.

2. Referenced Documents

2.1 ASTM Standards:

D 1121 Test Method for Reserve Alkalinity of Engine Coolants and Antirusts²

D 1287 Test Method for pH of Engine Coolants and Antirusts²

D 1384 Test Method for Corrosion Test for Engine Coolants in Glassware²

G 1 Practice for Preparing, Cleaning, and Evaluating Corrosion Test Specimens³

2.2 Federal Standard:⁴

CFR Title 29 OSHA Regulations

3. Summary of Test Method

3.1 This test method involves the operation of a standard passenger car engine on a dynamometer stand under constant speed, load, and coolant temperature conditions for a total of 700 h. The performance of the coolant is judged by examination of (1) coolant samples, (2) metal corrosion specimens, and (3) cooling system components.

4. Significance and Use

4.1 This test method provides a laboratory technique capable of reproducing the complex environmental stresses a coolant encounters under actual engine operating conditions. The test method provides improved discrimination over glassware and simulated service tests and improved correlation with field service. Although the test method is particularly valuable for developing coolants for increased service requirements, it remains that field testing is necessary to evaluate coolant performance completely.

5. Apparatus

5.1 *Test Engine*—The test engine shall be a volume production passenger car engine of cast iron or aluminum construction. Engine speed and brake horsepower should be calculated and adjusted to be equivalent to a 96.5 km/h (60 mph) level road load. Aluminum accessories, such as coolant pump and timing chain cover, are optional. The engine shall be equipped with a matching radiator and pressure cap. A coolant overflow reservoir and closed-system pressure cap are optional, except when specified by the manufacturer. Assemble the test components to provide a complete cooling system. The relative positioning of the radiator and engine should duplicate, as closely as practicable, the mounting in the automobile with the fan omitted. All radiator hose lengths should be held to a minimum. The radiator shall be cooled by forced air.

5.2 *Instrumentation and Control* (See Fig. 1)—Run the engine on a test stand coupled to an engine dynamometer with appropriate accessories for control of the designated operating conditions. Measure engine coolant temperature out of the engine at a point immediately adjacent to the coolant outlet. Measure manifold vacuum, oil pressure, and exhaust pressure at appropriate points and monitor them throughout the test in order to ensure proper engine performance. Install a pressure gage in the outlet tank of a crossflow radiator or the top tank of a downflow radiator to read the gage pressure.

5.3 Corrosion Measurements:

5.3.1 Evaluate corrosion protection using metal specimens. The specimen arrangement shall be basically that used in Test Method D 1384. The specimen bundle is shown in Fig. 2. Preparation, cleaning, and weighing of the metal specimens are described in Test Method D 1384 and Practice G 1. Each specimen bundle shall be held in a canvas-reinforced phenolic

¹ This test method is under the jurisdiction of ASTM Committee D-15 on Engine Coolants and is the direct responsibility of Subcommittee D15.10 on Dynamometer and Road Tests.

Current edition approved Dec. 15, 1994. Published February 1995. Originally published as D 2758 – 68 T. Last previous edition D 2758 – 86 (1991)^{ε 1}.

² *Annual Book of ASTM Standards*, Vol 15.05.

³ *Annual Book of ASTM Standards*, Vol 03.02.

⁴ Available from the Occupational Safety and Health Administration, 200 Constitution Ave., N.W., Washington, DC 20008.

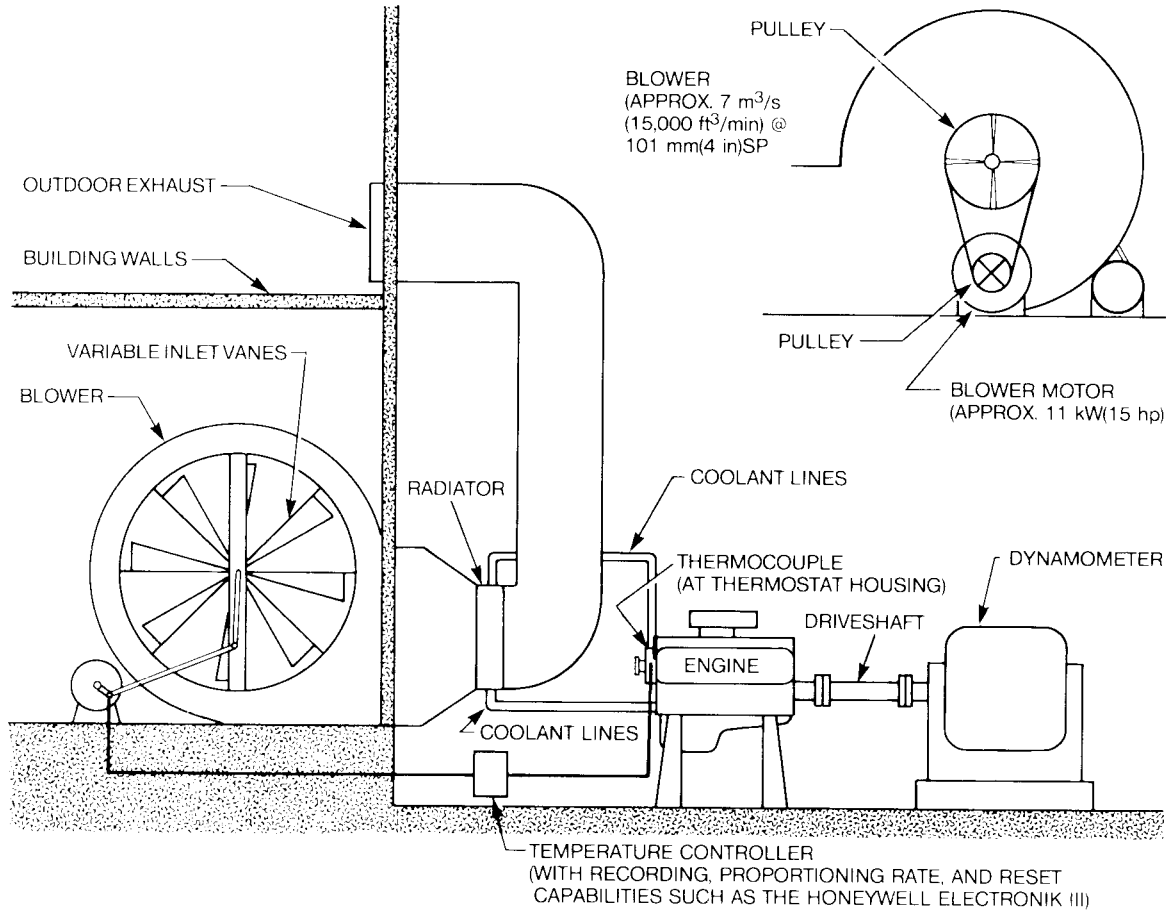

FIG. 1 Air Cooling Setup

tube (see Fig. 3) which, in turn, is contained in a capsule. Use two types of specimen capsules: full-flow and bypass. Install the full-flow capsule in the upper radiator hose, and connect the bypass capsule across the heater taps of the engine. Details of the capsules are shown in Fig. 4 and Fig. 5. The full-flow capsule shall contain three sets of specimens; weigh and replace one set with a fresh set at 100-h increments, and weigh two sets at the conclusion of the test. The bypass capsule shall contain three sets of specimens; clean, weigh, and replace the first set at 100-h increments. Clean and weigh the second set at 400 h. Replace, clean, and weigh this set at the end of the test. Clean and weigh the third set at the end of the test.

5.3.2 Position the full-flow capsule in the upper radiator hose at a point below the radiator coolant level.

5.3.3 The bypass capsule should be located in close proximity to the engine in order to avoid excessive coolant temperature drop.

5.3.4 Equip the bypass capsule with a temperature-measuring device to assure that normal flow is being maintained. (A temperature drop from normal operating temperature indicates an obstruction in the bypass circuit.) A mounting bracket attached to the radiator stand is recommended. Mount the capsule below the radiator coolant level in a vertical position. Connect the bottom fitting of the capsule with a rubber hose to the standard heater supply nipple, and connect the top fitting to the return nipple on the coolant pump.

5.4 Fuel and Crankcase Oil—Because of the extended

duration of this test, it is suggested that high-quality fuels and motor oils be selected to control combustion problems and achieve maximum valve life.

6. Precautions

6.1 Safety Precautions:

6.1.1 *Coolant*—All coolant concentrates and their solutions should be considered harmful or fatal if swallowed.

6.1.2 *Specimen Cleaning*—When cleaning aluminum specimens with chromic acid/orthophosphoric acid solution, use fume hood.

6.1.3 *Personal Protection*—Appropriate personal protection equipment (safety glasses, gloves, etc.) should be worn at all times when working with hot, pressurized engine systems. In general, engine speed should be lowered to 1000 rpm at no load, and the temperature and pressure on the cooling system should be lowered to a level below the boiling point of the coolant before approaching the engine. To avoid possible burns, care should be exercised in venting and opening the radiator pressure cap.

6.1.4 *Safety Guards*—Sturdy safety guards must be used for the fan belt, pulleys, couplings, and drive shaft (see OSHA Regulations, CFR Title 29).

6.1.5 *Maintenance of Physical Equipment*—In the operation and planning of the dynamometer test facility, adequate forethought must be given to the fuel system, exhaust system, fire hazards, and general housekeeping in order to maintain a high

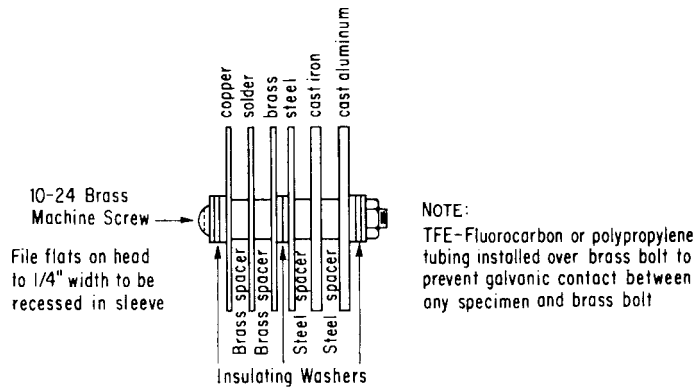

TYPICAL ASTM SPECIMEN BUNDLE ^A

NOTE 1—^A Alternate specimen bundles are shown in Test Method D 1384.

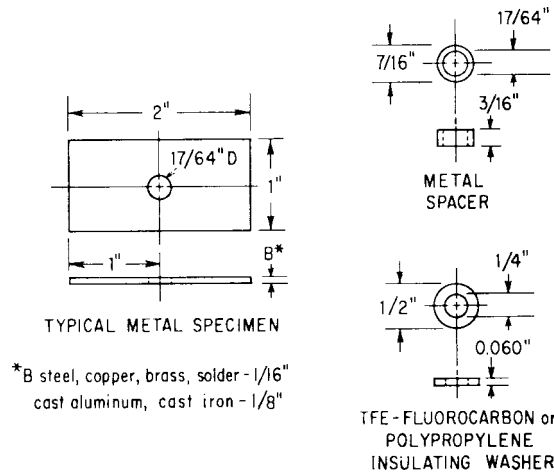

Metric Equivalents

in.	0.060	1/16	1/8	3/16	1/4	17/64	7/16	1/2	1	2
mm	1.52	1.59	3.18	4.76	6.35	6.75	11.11	12.7	25	51

FIG. 2 Corrosion Specimen Bundle

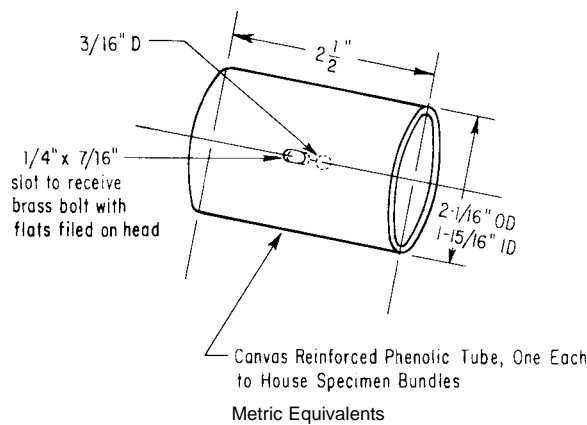

in.	3/16	1/4	7/16	1 15/16	2 1/16	2 1/2
mm	4.76	6.35	11.11	49.21	52.39	63.5

NOTE 1—To achieve snug fit of the specimen bundle in the tube, add insulating washers as necessary under the brass nut on the specimen bundle.

FIG. 3 Specimen Bundle Sleeve

level of safety standards. For example, checks for leaks in the fuel, oil, and exhaust systems must be made on a continuing

basis, and consideration must be given to the routing of a hot exhaust system in an area of combustible materials.

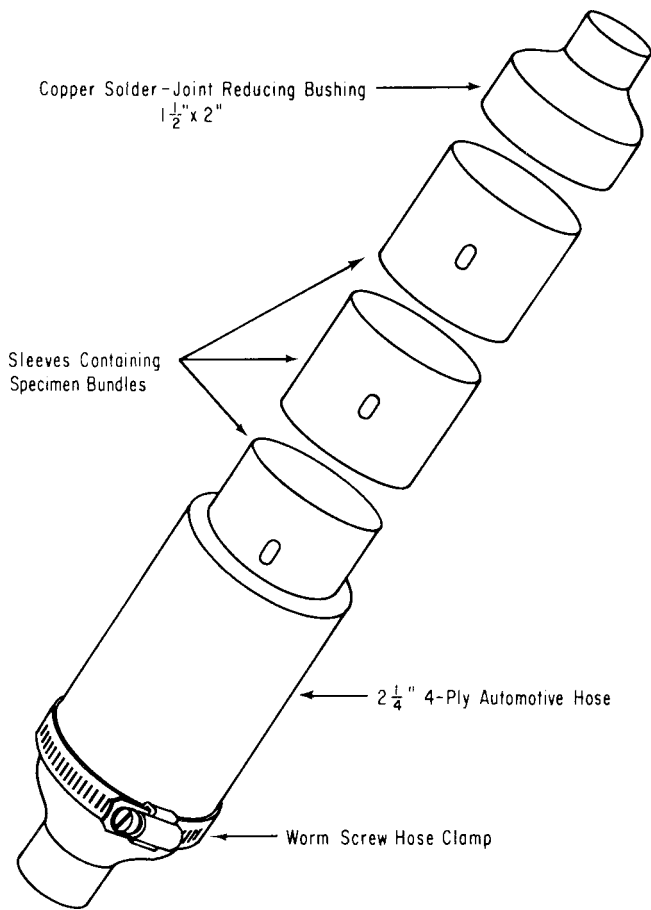

Metric Equivalents			
in.	1 1/2	2	2 1/4
mm	38	50.8	57

FIG. 4 Upper Radiator Hose Full Flow Specimen Capsule

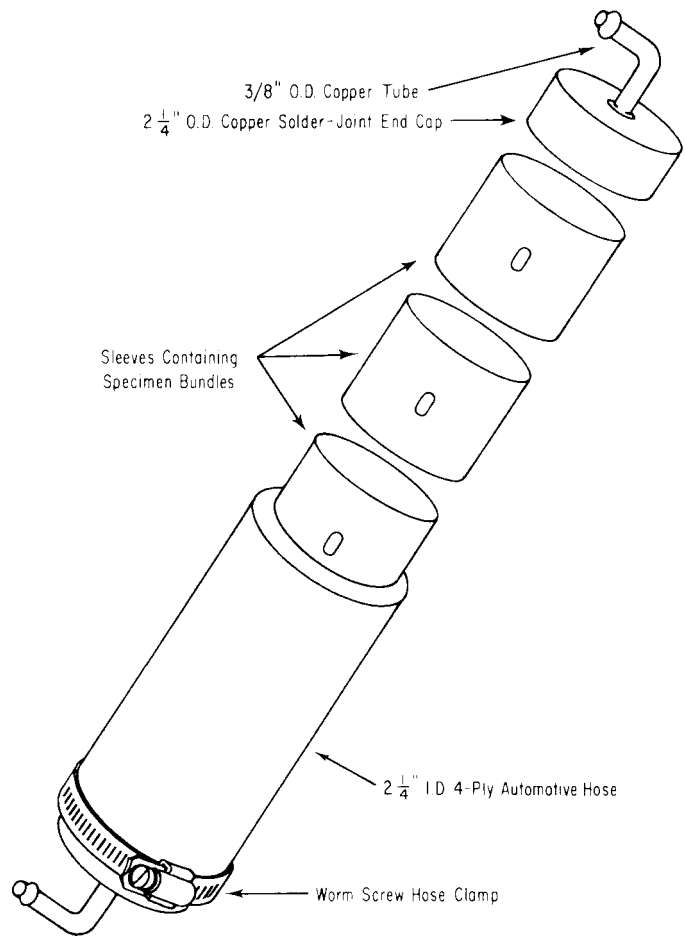

Metric Equivalents			
in	3/8	2 1/4	
mm	9.5	57	

FIG. 5 By-Pass Specimen Capsule

7. Preparation of Apparatus

7.1 Engine Reconditioning:

7.1.1 Check the engine and recondition, if necessary, prior to each test run. For each new engine, prior to a series of tests, and those engines being reconditioned for further testing, install new cylinder head gaskets; the engine manufacturer's recommendations should be followed regarding the use of gasket sealing compounds. When no specific recommendation is made by the engine manufacturer, the cylinder head gaskets and other coolant sealing gaskets should be coated with an adhesive sealant. This will ensure against coolant and exhaust gas leakage at some advanced point in the test, possibly voiding the test and its results. A new radiator should be installed before each test. The cooling system should be checked for the following common defects: (1) cylinder head gasket leakage resulting in exhaust gas contamination of the coolant, (2) air induction into the coolant due to a worn coolant pump seal, and (3) defective lower radiator hose connection. Methods of checking for these defects appear in Annex A1.

7.1.2 Clean the engine cooling system with a chelator-type commercial cleaner (see Annex A2). Replace all hoses after the cleaning procedure, but before each test.

7.2 Installation of Test Specimens and Coolant:

7.2.1 Prior to the installation of the coolant, install a new aluminum coolant outlet (if the engine is so equipped), along with a thermostat fixed in the full open position (see Note). Flat washers should be used under the coolant outlet-attaching bolt heads to minimize damage to the mounting flanges. Install the specimen-containing capsules at this time.

NOTE 1—Thermostats of different manufacturers have different design minimum travel positions. "Full open" would mean the *maximum* travel. To block a thermostat open, the power element should be drilled and tapped for an adjusting screw, soldered into position and cut off. Never solder the piston to the piston guide as this may cause damage or annealing of other thermostat components. To determine maximum travel, measure valve position equivalent to 11°C (20°F) above stamped opening temperature; for example, 89°C + 11°C = 100°C (192°F + 20°F = 212°F).

7.2.2 Based upon careful measurement of the volume of the system, add a measured amount of concentrated coolant directly to the cooling system to provide a 40 volume % coolant solution when filled to overflow with water containing 100 ppm each of chloride, sulfate, and bicarbonate ions (see Annex A3). If desired, single-phase-inhibited coolant may be premixed with corrosive water in a clean container and added to the cooling system as a solution. Under no conditions

premix external to the cooling system at the initiation of the test two-phase coolants containing polar oils. Before starting the test and after installing test coolant, conduct a 103-kPa (15-psi) pressure leakage test to check for external coolant leakage at hoses, gaskets, and coolant pump.

7.2.3 With the engine running at 1000 rpm no load and 93°C (200°F) coolant outlet temperature, drain sufficient coolant to bring the radiator level from overflow to 19 mm (¾ in.) below the pressure cap seat for down-flow radiators, and 38 mm (1½ in.) below the pressure cap seat for cross-flow radiators. (When radiator is equipped with an overflow reservoir and closed-system pressure cap, coolant level should be at the pressure cap seat.) Replace radiator cap. Save the drained coolant, and add it to 2-L (2-qt) sample of premixed 40 % test coolant and corrosive water solution to use as makeup throughout the test.

8. Procedure

8.1 Maintain the following test conditions throughout the test method, except for the inspections detailed in subsequent sections:

Coolant	40 volume % concentration of test coolant in 100-100-100 corrosive water
Coolant outlet temperature	93 ± 2°C (200 ± 3°F) or optional
Exhaust pressure	0 to 25.4 mm (0 to 1 in.) Hg
Test duration	700 h
Thermostat	Fixed to remain full open
Radiator cap	Standard specification for the engine cooling system
Coolant level	19 mm (¾ in.) below pressure cap seat for down-flow radiators 38 mm (1½ in.) below pressure cap seat for cross-flow radiators At pressure cap seat when radiator is equipped with an overflow reservoir and closed-system pressure cap
Speed and brake hP	Equivalent to 96.5 km/h (60 mph) level road load

8.2 Perform periodic inspections throughout the test, as given in Table 1.

9. Interpretation and Significance of Results

9.1 The test method is intended to provide a more comprehensive evaluation of coolant performance than is obtainable with glassware and stimulated service tests. Correlation with field service is generally good for engines of similar design and

material, but depends to a significant degree on the investigator's ability to interpret test results in relation to field service experience. Field service will inherently impose variations in severity.

9.2 The individual specimen weight loss values have limited significance in terms of absolute corrosion protection with respect to field service. Instead, they must be compared to baseline values established with coolants of known field service performance. The comparative weight loss values encountered with those specimens that remain undisturbed for the duration of the test indicate overall corrosion protection by the test coolant. These specimens should be the most valuable to predict field service performance. The specimens, which are replaced at predetermined intervals, and present a clean active surface, may be used to predict extended coolant performance as related to inhibitor depletion and formula degradation rate. A change in weight loss pattern may indicate coolant deterioration even though the solution characteristics and undisturbed specimen weight losses indicate a satisfactory condition.

9.3 Reserve alkalinity depletion also may be used to evaluate coolant service life and performance, provided proper precautions in interpretation are observed. After an initial reduction due to inhibitor reaction on cooling system surfaces, the reserve alkalinity will normally decrease gradually with test hours. Variation from this general pattern is cause for investigation.

9.4 The clean engine dynamometer test provides coolant evaluation under the duration, heat rejection, and other environmental conditions which exist in service. Results are particularly significant when related to a background of experience accumulated in a particular engine design. A comprehensive determination of general serviceability should include engine dynamometer tests in several types of engines and in prerusted as well as clean-cooling systems. For final proof, a new coolant formulation should be performance tested in field vehicles under actual driving conditions.

10. Report

10.1 Report the following information:

10.1.1 *Test Equipment and Operating Conditions:*

10.1.1.1 Engine make and model,

TABLE 1 Periodic Inspections

Occurrence	Operational Sequence
1 h, 100 h, and every 100 h thereafter	Reduce the engine speed to 1000 rpm no load and 93°C (200°F) coolant temperature. Withdraw 60-mL (2-oz) coolant sample. Samples should be analyzed in accordance with Test Methods D 1287 and D 1121.
Each 24-h operating	Reduce the engine speed to 1000 rpm no load and 93°C (200°F) coolant temperature. Remove the pressure cap. Check the coolant level and, if required, adjust to the prescribed level with the reserve premixed makeup solution. The 2 L (2 qt) of reserve makeup solution should be enough for the entire test. However, if more additions are needed, they must be recorded and reported.
Each 100-h operating period	Stop the engine and withdraw the 60-mL (2-oz) coolant sample. Remove the 100-h incremental specimen bundle for weighing. Replace with a new bundle. Withdraw sufficient coolant from the system to permit addition of all available reserve makeup solution. Retain the withdrawn coolant reserve makeup and rotate at the next 100-h checkpoint. Change the crankcase oil. Adjust the coolant level, replace the pressure cap, and return engine to test operation.
400 h of operation	In addition to 100-h incremental specimens, remove and weigh the 400-h bypass specimens. Replace with a new bundle (400 to 700 h).
700 h of operation	Terminate the test. Withdraw 500-mL (1-pt) coolant sample and remove all of the test components. Clean and weigh the specimens.

10.1.1.2 Radiator make and model,
 10.1.1.3 Average engine speed, rpm,

10.1.2.1 Test coolant identification,
 10.1.2.2 Volume of coolant in the system at the start of the

TABLE 2 Repeatability in Three ASTM Engine Dynamometer Tests: One Laboratory with Coolant B

Inspection Periods and Samples	Corrosion Weight Losses, mg per Specimen					
	Upper Radiator Hose			Bypass Capsule		
	Test 1	Test 2	Test 3	Test 1	Test 2	Test 3
0 to 100 h:						
Cast aluminum	9	2	1	2	0	0
Cast iron	4	1	1	3	+1	+2
Steel	2	1	0	7	0	+1
Brass	15	4	3	9	1	2
Solder	7	9	0	7	9	1
Copper	10	6	1	8	1	1
0 to 400 h:						
Cast aluminum				14	4	3
Cast iron				5	0	+3
Steel				1	1	0
Brass				10	5	11
Solder				8	2	1
Copper				13	5	3
(Average of Two Bundles)						
0 to 700 h:						
Cast aluminum	11	5	3	17	6	3
Cast iron	4	+2	+2	5	+1	0
Steel	1	0	0	3	0	0
Brass	13	2	3	5	2	3
Solder	5	+1	2	8	1	2
Copper	10	2	2	11	2	3

TABLE 3 Reproducibility in ASTM Engine Dynamometer Tests: Three Different Laboratories with Coolant C

Inspection Periods and Samples	Corrosion Weight Losses, mg per Specimen					
	Upper Radiator Hose			Bypass Capsule		
	Lab C	Lab J	Lab U	Lab C	Lab J ^A	Lab U
0 to 100 h:						
Cast aluminum	(850) ^B	114	92	30	76	136
Cast iron	1	0	+2	1	0	0
Steel	1	1	2	1	1	0
Brass	8	15	5	9	13	11
Solder	54	115	73	62	107	62
Copper	7	16	4	7	15	1
0 to 400 h:						
Cast aluminum				35	119	30
Cast iron				(100) ^B	2	1
Steel				1	2	2
Brass				9	21	9
Solder				55	91	131
Copper				9	27	13
(Average of Two Bundles Except Lab C)						
0 to 700 h:						
Cast aluminum	73	161	106	46	123	66
Cast iron	+2	1	1	0	1	2
Steel	1	1	3	1	2	2
Brass	4	22	7	3	20	14
Solder	60	96	129	44	100	137
Copper	3	29	5	3	32	11

^ALaboratory J ran a test engine used in previous test procedures which included cleaning with oxalic acid. Other engine test work has shown that previous acid cleaning can increase specimen weight losses.

^BWeight loss value considered anomalous and was discarded.

10.1.1.4 Average engine load, bhp,
 10.1.1.5 Average coolant outlet temperature, °C (°F),
 10.1.1.6 Test duration, h, and
 10.1.1.7 Accumulated engine hours at the start of the test.
 10.1.2 *Coolant Information:*

test,
 10.1.2.3 Coolant additions during test (corrected for samples),
 10.1.2.4 pH and reserve alkalinity of coolant samples every 100 h,

10.1.2.5 Appearance of coolant samples every 100 h, and

10.1.2.6 Glycol content of coolant samples every 100 h.

10.1.3 *Corrosion Data:*

10.1.3.1 Corrosion specimen weight losses, milligrams per specimen, for each 100 h, for 400 h, from 400 to 700 h, and for 700 h,

10.1.3.2 Condition of the radiator at the conclusion of the test, inspected by sectioning representative areas of the tubes, top tank, and bottom tank, and

10.1.3.3 Condition of engine coolant jacket interior at the conclusion of the test, as viewed through the coolant outlet opening or other accessible opening.

11. Precision and Bias

11.1 Repeatability is generally good, particularly when corrosion rates are low, although large deviations may occur occasionally with the poorer performing coolants. Standard deviations are generally greater when higher weight losses are experienced. Variations result from differences in specimen

composition, grain structure and surface finish, and the random nature of corrosion phenomena. Operating variables affecting the data include the amount of air inducted during the test, residual contaminants in the cooling system at the start of the test, and the amount of fresh coolant added during the test. It is not unusual for the highest weight loss of a given metal to exceed the lowest by a magnitude of four or more.

11.2 Reproducibility among different laboratories is generally poorer than repeatability and tends to become worse as corrosion increases, especially when specimen weight losses exceed 50 mg per specimen.

11.3 Table 2 shows the repeatability established by one laboratory with three tests on the same formula, Coolant B. Table 3 shows the reproducibility established by three laboratories running one test each on the same formula, Coolant C.

12. Keywords

12.1 dynamometer; engine coolants; engine dynamometer

ANNEXES

(Mandatory Information)

A1. DETECTION OF EXHAUST GAS LEAKAGE AND AIR INDUCTION

A1.1 Exhaust Gas Leakage Test

A1.1.1 Cylinder head joint failure resulting in exhaust gas contamination of the coolant may be detected by one of the following procedures:

A1.1.1.1 A carbon monoxide detector may be used for checking gases deaerating from the coolant water running the engine at 35 hp and 2800 rpm for 15 min and returning to idle. With the radiator cap off, gas samples can be taken near the surface of the coolant in the top tank. A positive result should be treated with discretion because false indications of carbon monoxide can be obtained from other possible vapor components such as hydrogen and ethylene glycol. For this reason, the following “quick-check” should be performed for confirmation or as an alternative.

A1.1.1.2 Start the “quick-check” with the engine cold. Remove the fan belt from the water pump drive pulley to prevent pump operation. Drain the system until the coolant is just below the thermostat housing level. Remove the housing and thermostat; then add water until it overflows at the thermostat opening. Start the engine and quickly load to 22.5 bhp, 1800 rpm. The appearance of bubbles or sudden rise of

liquid at the block outlet to the radiator indicates exhaust gas leakage. The test must be run quickly before boiling starts because steam bubbles give misleading results.

A1.2 Air Induction Test

A1.2.1 An air induction test should not be performed until it is certain that exhaust gas leakage is not occurring. Suction of air into the system at a defective lower radiator hose connection or because of a worn coolant pump thrust seal may be detected as follows:

A1.2.1.1 Adjust the liquid level in the radiator, allowing room for expansion, to avoid any overflow during test. Replace the normally used pressure cap with a plain, airtight cap. Attach a length of rubber tube to the lower end of the overflow pipe. Radiator cap, overflow pipe, and rubber tube connections must be airtight. Run engine at speed and under load to stabilize the coolant temperature at 93°C (200°F). Without changing operating conditions, put the end of the rubber tube into a bottle of water, avoiding kinks or loops that might block the flow of air. A continuous stream of bubbles in the water bottle indicates that air is being drawn into the cooling system.

A2. ENGINE COOLING SYSTEM CLEANING PROCEDURE

A2.1 Drain the cooling system. Remove the thermostat.

A2.2 Fill cooling system with tap water. Add manufacturer's recommended concentration of chelator type commercial cleaner. Run 1 h at speed and under load to stabilize coolant temperature at 93°C (200°F). Drain.

A2.3 Reverse flush with hot water 60 to 71°C (140 to 160°F) for 5 min. Drain.

A2.4 Fill cooling system with tap water. Run 15 min at speed and under load to stabilize coolant temperature at 93°C (200°F). Drain.

A2.5 Reverse flush with hot water 60 to 71°C (140 to 160°F) for 5 min. Drain.

A2.6 Repeat steps A2.4 and A2.5, and take a 4-oz (100-mL) bottle sample before draining. If there is sediment present, or if foaming is evident, repeat steps A2.4 and A2.5 again, or repeat as many times as necessary to obtain a clear, non-foaming sample.

A2.7 Replace all hoses carrying coolant.

A2.8 Install test coolant immediately.

NOTE A2.1—Any new, used, or reconditioned engine exhibiting excessive rusting which cannot be cleaned by this procedure should be replaced.

A3. PREPARATION OF CORROSIVE WATER

A3.1 The specified corrosive water can be prepared by dissolving the following amounts of anhydrous sodium salts in a quantity of distilled or deionized water:

sodium sulfate	148 g
sodium chloride	165 g
sodium bicarbonate	138 g

The resulting solution should be made up to a volume of 1 L with distilled or deionized water at 20°C.

A3.1.1 If relatively large amounts of corrosive water are needed for testing, a concentrate may be prepared by dissolving ten times the above amounts of the three chemicals, in distilled or deionized water, and adjusting the total volume to 1 L by further additions of distilled or deionized water. When needed, the corrosive water concentrate is diluted to the ratio of one part by volume of concentrate to nine parts of distilled or deionized water.

The American Society for Testing and Materials takes no position respecting the validity of any patent rights asserted in connection with any item mentioned in this standard. Users of this standard are expressly advised that determination of the validity of any such patent rights, and the risk of infringement of such rights, are entirely their own responsibility.

This standard is subject to revision at any time by the responsible technical committee and must be reviewed every five years and if not revised, either reapproved or withdrawn. Your comments are invited either for revision of this standard or for additional standards and should be addressed to ASTM Headquarters. Your comments will receive careful consideration at a meeting of the responsible technical committee, which you may attend. If you feel that your comments have not received a fair hearing you should make your views known to the ASTM Committee on Standards, 100 Barr Harbor Drive, West Conshohocken, PA 19428.