



Standard Test Method for Motor Octane Number of Spark-Ignition Engine Fuel¹

This standard is issued under the fixed designation D 2700; the number immediately following the designation indicates the year of original adoption or, in the case of revision, the year of last revision. A number in parentheses indicates the year of last reapproval. A superscript epsilon (ϵ) indicates an editorial change since the last revision or reapproval.

1. Scope*

1.1 This laboratory test method covers the quantitative determination of the knock rating of liquid spark-ignition engine fuel in terms of Motor octane number except that this test method may not be applicable to fuel and fuel components that are primarily oxygenates.² The sample fuel is tested in a standardized single cylinder, four-stroke cycle, variable compression ratio, carbureted, CFR engine run in accordance with a defined set of operating conditions. The octane number scale is defined by the volumetric composition of primary reference fuel blends. The sample fuel knock intensity is compared to that of one or more primary reference fuel blends. The octane number of the primary reference fuel blend that matches the knock intensity of the sample fuel establishes the Motor octane number.

1.2 The octane number scale covers the range from 0 to 120 octane number, but this test method has a working range from 40 to 120 octane number. Typical commercial fuels produced for automotive spark-ignition engines rate in the 80 to 90 Motor octane number range. Typical commercial fuels produced for aviation spark-ignition engines rate in the 98 to 102 Motor octane number range. Testing of gasoline blend stocks or other process stream materials can produce ratings at various levels throughout the Motor octane number range.

1.3 The values of operating conditions are stated in SI units and are considered standard. The values in parentheses are the historical inch-pounds units. The standardized CFR engine measurements continue to be in inch-pound units only because of the extensive and expensive tooling that has been created for this equipment.

1.4 *This standard does not purport to address all of the safety concerns, if any, associated with its use. It is the responsibility of the user of this standard to establish appropriate safety and health practices and determine the applica-*

bility of regulatory limitations prior to use. For more specific hazard statements, see Section 8, 13.4.1, 14.5.1, 15.6.1, Annex A1, A2.3.9, A2.4.8, A3.2.7.2(7), A4.2.3.1, A4.2.3.3(6) and (9), A4.3.5, X2.3.7, X3.2.3.1, X3.3.4.1, X3.3.9.3, X3.3.12.4, and X3.5.1.8.

2. Referenced Documents

2.1 ASTM Standards:³

- D 1193 Specification for Reagent Water
- D 1744 Test Method for Water in Liquid Petroleum Products by Karl Fischer Reagent⁴
- D 2268 Test Method for Analysis of High-Purity *n*-Heptane and Isooctane by Capillary Gas Chromatography
- D 2360 Test Method for Trace Impurities in Monocyclic Aromatic Hydrocarbons by Gas Chromatography
- D 2699 Test Method for Research Octane Number of Spark-Ignition Engine Fuel
- D 2885 Test Method for Determination of Octane Number of Spark-Ignition Engine Fuels by On-Line Direct Comparison Technique
- D 3703 Test Method for Peroxide Number of Aviation Turbine Fuels
- D 4057 Practice for Manual Sampling of Petroleum and Petroleum Products
- D 4175 Terminology Relating to Petroleum, Petroleum Products, and Lubricants
- D 4177 Practice for Automatic Sampling of Petroleum and Petroleum Products
- D 4814 Specification for Automotive Spark-Ignition Engine Fuel
- D 5842 Practice for Sampling and Handling of Fuels for Volatility Measurement
- E 1 Specification for ASTM Thermometers
- E 456 Terminology for Relating to Quality and Statistics
- E 542 Practice for Calibration of Laboratory Volumetric Apparatus

¹ This test method is under the jurisdiction of ASTM Committee D02 on Petroleum Products and Lubricants and is the direct responsibility of Subcommittee D02.01 on Combustion Characteristics.

Current edition approved Nov. 1, 2003. Published November 2003. Originally approved in 1968. Last previous edition approved in 2003 as D 2700–03a.

² Research octane number, determined using Test Method D 2699, is a companion method to provide a similar but typically higher octane rating under milder operating conditions.

³ For referenced ASTM standards, visit the ASTM website, www.astm.org, or contact ASTM Customer Service at service@astm.org. For *Annual Book of ASTM Standards* volume information, refer to the standard's Document Summary page on the ASTM website.

⁴ Withdrawn.

*A Summary of Changes section appears at the end of this standard.

2.2 ANSI Standard:⁵

C-39.1 Requirements for Electrical Analog Indicating Instruments

2.3 IP Standard:

IP 224/02 Determination of Low Lead Content of Light Petroleum Distillates by Dithizone Extraction and Colorimetric Method⁶

3. Terminology

3.1 Definitions:

3.1.1 *accepted reference value, n*—a value that serves as an agreed-upon reference for comparison, and which is derived as: (1) a theoretical or established value, based on scientific principles, (2) an assigned or certified value, based on experimental work of some national or international organization, or (3) a consensus or certified value, based on collaborative experimental work under the auspices of a scientific or engineering group. **E 456**

3.1.1.1 *Discussion*—In the context of this test method, accepted reference value is understood to apply to the Motor octane number of specific reference materials determined empirically under reproducibility conditions by the National Exchange Group or another recognized exchange testing organization.

3.1.2 *Check Fuel, n*—for quality control testing, a spark-ignition engine fuel of selected characteristics having an octane number accepted reference value (O.N._{ARV}) determined by round-robin testing under reproducibility conditions.

3.1.3 *cylinder height, n*—for the CFR engine, the relative vertical position of the engine cylinder with respect to the piston at top dead center (tdc) or the top machined surface of the crankcase.

3.1.4 *detonation meter, n*—for knock testing, the signal conditioning instrumentation that accepts the electrical signal from the detonation pickup and provides an output signal for display.

3.1.5 *detonation pickup, n*—for knock testing, a magnetostrictive-type transducer that threads into the engine cylinder and is exposed to combustion chamber pressure to provide an electrical signal that is proportional to the rate-of-change of cylinder pressure.

3.1.6 *dial indicator reading, n*—for the CFR engine, a numerical indication of cylinder height, in thousandths of an inch, indexed to a basic setting at a prescribed compression pressure when the engine is motored.

3.1.7 *digital counter reading, n*—for the CFR engine, a numerical indication of cylinder height, indexed to a basic setting at a prescribed compression pressure when the engine is motored.

3.1.8 *dynamic fuel level, n*—for knock testing, test procedure in which the fuel-air ratio for maximum knock intensity for sample and reference fuels is determined using the falling level technique that changes carburetor fuel level from a high

or rich mixture condition to a low or lean mixture condition, at a constant rate, causing knock intensity to rise to a maximum and then decrease, thus permitting observation of the maximum knockmeter reading.

3.1.9 *equilibrium fuel level, n*—for knock testing, test procedure in which the fuel-air ratio for maximum knock intensity for sample and reference fuels is determined by making incremental step changes in carburetor fuel level, observing the equilibrium knock intensity for each step, and selecting the level which produces the highest knock intensity reading.

3.1.10 *firing, n*—for the CFR engine, operation of the CFR engine with fuel and ignition.

3.1.11 *fuel-air ratio for maximum knock intensity, n*—for knock testing, that proportion of fuel to air that produces the highest knock intensity for each fuel in the knock testing unit, provided this occurs within specified carburetor fuel level limits.

3.1.12 *guide tables, n*—for knock testing, the specific relationship between cylinder height (compression ratio) and octane number at standard knock intensity for specific primary reference fuel blends tested at standard or other specified barometric pressure.

3.1.13 *knock, n*—in a spark-ignition engine, abnormal combustion, often producing audible sound, caused by autoignition of the air/fuel mixture. **D 4175**

3.1.14 *knock intensity, n*—for knock testing, a measure of the level of knock.

3.1.15 *knockmeter, n*—for knock testing, the 0 to 100 division indicating meter that displays the knock intensity signal from the detonation meter.

3.1.16 *motoring, n*—for the CFR engine, operation of the CFR engine without fuel and with the ignition shut off.

3.1.17 *motor octane number, n*—for spark-ignition engine fuel, the numerical rating of knock resistance obtained by comparison of its knock intensity with that of primary reference fuels when both are tested in a standardized CFR engine operating under the conditions specified in this test method.

3.1.18 *octane number, n*—for spark-ignition engine fuel, any one of several numerical indicators of resistance to knock obtained by comparison with reference fuels in standardized engine or vehicle tests. **D 4175**

3.1.19 *oxygenate, n*—an oxygen-containing organic compound, which may be used as a fuel or fuel supplement, for example, various alcohols and ethers. **D 4175**

3.1.20 *primary reference fuel blends above 100 octane, n*—the millilitres per U.S. gallon of tetraethyllead in *isooctane* that define octane numbers above 100 in accordance with an empirically determined relationship.

3.1.21 *primary reference fuels, n*—for knock testing, *isooctane, n*-heptane, volumetrically proportioned mixtures of *isooctane* with *n*-heptane, or blends of tetraethyllead in *isooctane* that define the octane number scale.

3.1.22 *primary reference fuel blends below 100 octane, n*—the volume percent of *isooctane* in a blend with *n*-heptane that defines the octane number of the blend, *isooctane* being assigned as 100 and *n*-heptane as zero octane number.

3.1.23 *repeatability conditions, n*—conditions where independent test results are obtained with the same method on

⁵ Available from American National Standards Institute (ANSI), 25 W. 43rd St., 4th Floor, New York, NY 10036.

⁶ Available from the Institute of Petroleum, 61 New Cavendish St., London W1G 7AR, UK.

identical test items in the same laboratory by the same operator using the same equipment within short intervals of time.

E 456

3.1.23.1 *Discussion*—In the context of this test method, a short time interval between two ratings on a sample fuel is understood to be not less than the time to obtain at least one rating on another sample fuel between them but not so long as to permit any significant change in the sample fuel, test equipment, or environment.

3.1.24 *reproducibility conditions, n*—conditions where test results are obtained with the same method on identical test items in different laboratories with different operators using different equipment.

E 456

3.1.25 *spread, n*—in knock measurement, the sensitivity of the detonation meter expressed in knockmeter divisions per octane number.

3.1.26 *standard knock intensity, n*—for knock testing, that level of knock established when a primary reference fuel blend of specific octane number is used in the knock testing unit at maximum knock intensity fuel-air ratio, with the cylinder height (dial indicator or digital counter reading) set to the prescribed guide table value. The detonation meter is adjusted to produce a knockmeter reading of 50 for these conditions.

3.1.27 *toluene standardization fuels, n*—for knock testing, those volumetrically proportioned blends of two or more of the following: reference fuel grade toluene, *n*-heptane, and *isooctane* that have prescribed rating tolerances for O.N._{ARV} determined by round-robin testing under reproducibility conditions.

3.2 *Abbreviations:*

- 3.2.1 *ARV*—accepted reference value
- 3.2.2 *C.R.*—compression ratio
- 3.2.3 *IAT*—intake air temperature
- 3.2.4 *K.I.*—knock intensity
- 3.2.5 *MIXT*—mixture temperature
- 3.2.6 *O.N.*—octane number
- 3.2.7 *PRF*—primary reference fuel
- 3.2.8 *TSF*—toluene standardization fuel

4. Summary of Test Method

4.1 The Motor O.N. of a spark-ignition engine fuel is determined using a standard test engine and operating conditions to compare its knock characteristic with those of PRF blends of known O.N. Compression ratio and fuel-air ratio are adjusted to produce standard K.I. for the sample fuel, as measured by a specific electronic detonation meter instrument system. A standard K.I. guide table relates engine C.R. to O.N. level for this specific method. The fuel-air ratio for the sample fuel and each of the PRF blends is adjusted to maximize K.I. for each fuel.

4.1.1 The fuel-air ratio for maximum K.I. may be obtained (1) by making incremental step changes in mixture strength, observing the equilibrium K.I. value for each step, and then selecting the condition which maximizes the reading or (2) by picking the maximum K.I. as the mixture strength is changed from either rich-to-lean or lean-to-rich at a constant rate.

4.2 *Bracketing Procedures*—The engine is calibrated to operate at standard K.I. in accordance with the guide table. The fuel-air ratio of the sample fuel is adjusted to maximize the K.I., and then the cylinder height is adjusted so that standard

K.I. is achieved. Without changing cylinder height, two PRFs are selected such that, at their fuel-air ratio for maximum K.I., one knocks harder (higher K.I.) and the other softer (lower K.I.) than the sample fuel. A second set of K.I. measurements for sample fuel and reference fuels is required, and the sample fuel O.N. is calculated by interpolation in proportion to the differences in average K.I. readings. A final condition requires that the cylinder height used shall be within prescribed limits around the guide table value for the calculated O.N. Bracketing procedure ratings may be determined using either the equilibrium fuel level or dynamic fuel level approach.

4.3 *C.R. Procedure*—A calibration is performed to establish standard K.I. using the cylinder height specified by the guide table for the O.N. of the selected PRF. The fuel-air ratio of the sample fuel is adjusted to maximize the K.I. under equilibrium conditions; the cylinder height is adjusted so that standard K.I. is achieved. The calibration is reconfirmed and the sample fuel rating is repeated to establish the proper conditions a second time. The average cylinder height reading for the sample fuel, compensated for barometric pressure, is converted directly to O.N. using the guide table. A final condition for the rating requires that the sample fuel O.N. be within prescribed limits around that of the O.N. of the single primary reference blend used to calibrate the engine to the guide table standard K.I. condition.

5. Significance and Use

5.1 Motor O.N. correlates with commercial automotive spark-ignition engine antiknock performance under severe conditions of operation.

5.2 Motor O.N. is used by engine manufacturers, petroleum refiners and marketers, and in commerce as a primary specification measurement related to the matching of fuels and engines.

5.2.1 Empirical correlations that permit calculation of automotive antiknock performance are based on the general equation:

$$\text{Road O.N.} = (k_1 \times \text{Research O.N.}) + (k_2 \times \text{Motor O.N.}) + k_3 \quad (1)$$

Values of k_1 , k_2 , and k_3 vary with vehicles and vehicle populations and are based on road-octane number determinations.

5.2.2 Motor O.N., in conjunction with Research O.N., defines the antiknock index of automotive spark-ignition engine fuels, in accordance with Specification D 4814. The antiknock index of a fuel approximates the road octane ratings for many vehicles, is posted on retail dispensing pumps in the United States, and is referred to in vehicle manuals.

$$\text{Antiknock Index} = 0.5 \text{ Research O.N.} + 0.5 \text{ Motor O.N.} + 0 \quad (2)$$

This is more commonly presented as:

$$\text{Antiknock Index} = \frac{(R + M)}{2} \quad (3)$$

5.3 Motor O.N. is used for measuring the antiknock performance of spark-ignition engine fuels that contain oxygenates.

5.4 Motor O.N. is important in relation to the specifications for spark-ignition engine fuels used in stationary and other nonautomotive engine applications.

5.5 Motor O.N. is utilized to determine, by correlation equation, the Aviation method O.N. or performance number (lean-mixture aviation rating) of aviation spark-ignition engine fuel.⁷

6. Interferences

6.1 *Precaution*—Avoid exposure of sample fuels to sunlight or fluorescent lamp UV emissions to minimize induced chemical reactions that can affect octane number ratings.⁸

6.1.1 Exposure to these fuels to UV wavelengths shorter than 550 nm for a short period of time may significantly affect octane number ratings.

6.2 Certain gases and fumes, which can be present in the area where the knock testing unit is located, may have a measurable effect on the Motor O.N. test result.

6.2.1 Halogenated refrigerant used in air conditioning and refrigeration equipment can promote knock. Halogenated solvents can have the same effect. If vapors from these materials enter the combustion chamber of the CFR engine, the Motor O.N. obtained for sample fuels can be depreciated.

6.3 Electrical power subject to transient voltage or frequency surges or distortion can alter CFR engine operating conditions or knock measuring instrumentation performance and thus affect the Motor O.N. obtained for sample fuels.

7. Apparatus

7.1 *Engine Equipment*⁹—This test method uses a single cylinder, CFR engine that consists of standard components as follows: crankcase, a cylinder/clamping sleeve assembly to provide continuously variable C.R. adjustable with the engine operating, a thermal syphon recirculating jacket coolant system, a multiple fuel tank system with selector valving to deliver fuel through a single jet passage and carburetor venturi, an intake air system with controlled temperature and humidity equipment, electrical controls, and a suitable exhaust pipe. The engine flywheel is belt connected to a special electric power-absorption motor utilized to both start the engine and as a means to absorb power at constant speed when combustion is occurring (engine firing). See Fig. 1.

7.1.1 See Annex A2 for details and a description of all critical, non-critical, and equivalent engine equipment.

7.2 *Instrumentation*⁹—This test method uses electronic detonation metering instrumentation to measure the intensity of combustion knock as well as conventional thermometry, gages, and general purpose meters.

7.2.1 See Annex A3 for details and a description of all critical, non-critical, and equivalent instrumentation.

⁷ Correlation information is given in ASTM research report RR:D02-69, Aviation Gasoline Antiknock Quality by ASTM Methods D 614 and D 357. (Replaced by Test Method D 2700.) Refer to the Report Section, in this test method, for application of the correlation relationship.

⁸ Supporting data have been filed at ASTM International Headquarters and may be obtained by requesting Research Report RR: D02-1502.

⁹ The sole source of supply of the engine equipment and instrumentation known to the committee at this time is Waukesha Engine, Dresser, Inc., 1000 W. St. Paul Avenue, Waukesha, WI 53188. Waukesha Engine also has CFR engine authorized sales and service organizations in selected geographical areas. If you are aware of alternative suppliers, please provide this information to ASTM International Headquarters. Your comments will receive careful consideration at a meeting of the responsible technical committee¹, which you may attend.

7.3 *Reference and Standardization Fuel Dispensing Equipment*—This test method requires repeated blending of reference fuels and TSF materials in volumetric proportions. In addition, blending of dilute tetraethyllead in *isooctane* may be performed on-site for making rating determinations above 100 O.N. Blending shall be performed accurately because rating error is proportional to blending error.

7.3.1 *Volumetric Blending of Reference Fuels*—Volumetric blending has historically been employed to prepare the required blends of reference fuels and TSF materials. For volumetric blending, a set of burets, or accurate volumetric apparatus, shall be used and the desired batch quantity shall be collected in an appropriate container and thoroughly mixed before being introduced to the engine fuel system.

7.3.1.1 Calibrated burets or volumetric apparatus having a capacity of 200 to 500 mL and a maximum volumetric tolerance of $\pm 0.2\%$ shall be used for preparation of reference and standardization fuel blends. Calibration shall be verified in accordance with Practice E 542.

7.3.1.2 Calibrated burets shall be outfitted with a dispensing valve and delivery tip to accurately control dispensed volume. The delivery tip shall be of such design that shut-off tip discharge does not exceed 0.5 mL.

7.3.1.3 The rate of delivery from the dispensing system shall not exceed 400 mL per 60 s.

7.3.1.4 The set of burets for the reference and standardization fuels shall be installed in such a manner and be supplied with fluids such that all components of each batch or blend are dispensed at the same temperature.

7.3.1.5 See Appendix X1 for volumetric reference fuel dispensing system information.

7.3.2 *Volumetric Blending of Tetraethyllead*—A calibrated buret, pipette assembly, or other liquid dispensing apparatus having a capacity of not more than 4.0 mL and a critically controlled volumetric tolerance shall be used for dispensing dilute tetraethyllead into 400 mL batches of *isooctane*. Calibration of the dispensing apparatus shall be verified in accordance with Practice E 542.

7.3.3 *Gravimetric Blending of Reference Fuels*—Use of blending systems that allow preparation of the volumetrically-defined blends by gravimetric (mass) measurements based on the density of the individual components is also permitted, provided the system meets the requirement for maximum 0.2 % blending tolerance limits.

7.3.3.1 Calculate the mass equivalents of the volumetrically-defined blend components from the densities of the individual components at 15.56°C (60°F).

7.4 Auxiliary Apparatus:

7.4.1 *Special Maintenance Tools*—A number of specialty tools and measuring instruments should be utilized for easy, convenient, and effective maintenance of the engine and testing equipment. Lists and descriptions of these tools and instruments are available from the manufacturer of the engine equipment and those organizations offering engineering and service support for this test method.

7.4.2 *Ventilation Hoods*—Handling of reference and standardization fuels, dilute tetraethyllead, and sample fuels having various hydrocarbon compositions is best conducted in a well

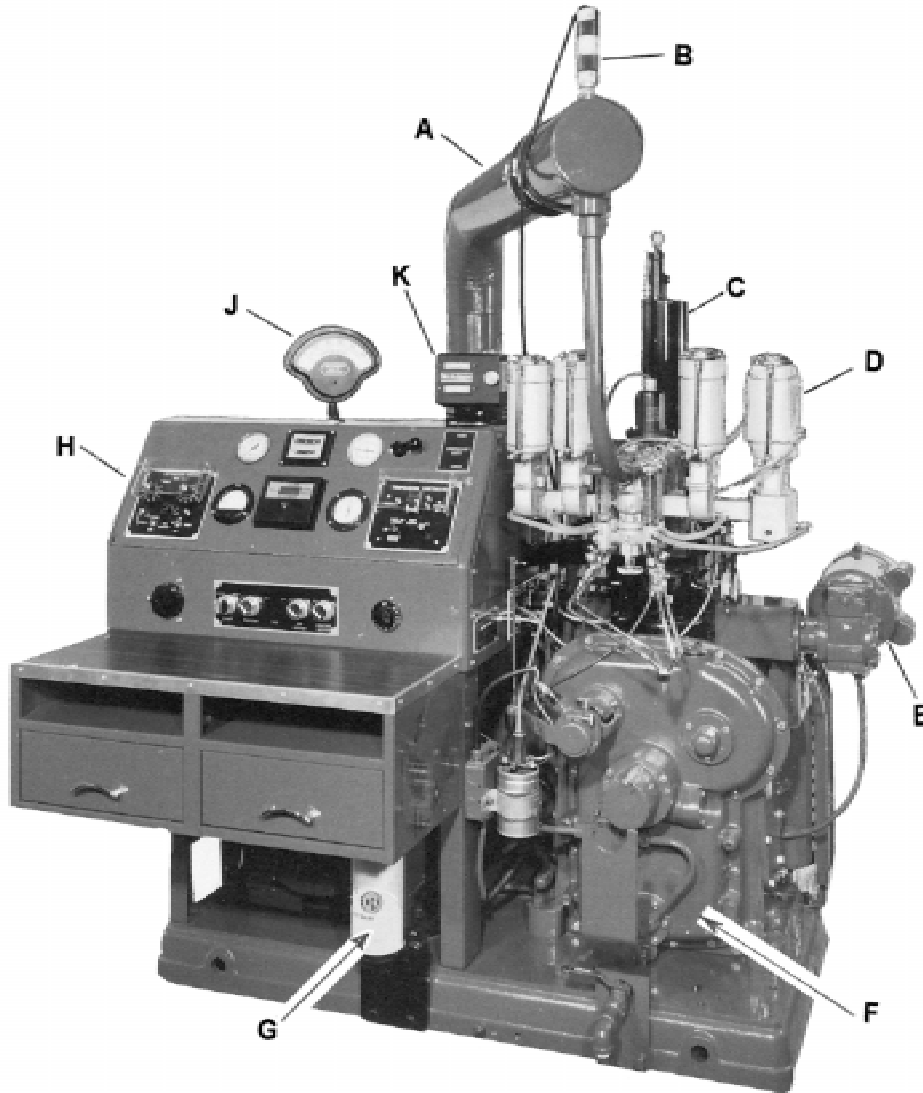

- A—Air humidifier tube
- B—Intake air heater
- C—Coolant condenser
- D—Four bowl carburetor
- E—C.R. change motor
- F—CFR-48 crankcase
- G—Oil filter
- H—Detonation meter
- J—Knockmeter
- K—C.R. digital counter

FIG. 1 Motor Method Test Engine Assembly

ventilated space or in a laboratory hood where air movement across the area is sufficient to prevent operator inhalation of vapors.

7.4.2.1 General purpose laboratory hoods are typically effective for handling hydrocarbon fuel blending.¹⁰

7.4.2.2 A blending hood meeting the requirements for dispensing toxic material shall be utilized in testing laboratories that choose to prepare leaded *isooctane* PRF blends on-site.

8. Reagents and Reference Materials

8.1 *Cylinder Jacket Coolant*—Water shall be used in the cylinder jacket for laboratory locations where the resultant boiling temperature shall be $100 \pm 1.5^\circ\text{C}$ ($212 \pm 3^\circ\text{F}$). Water with commercial glycol-based antifreeze added in sufficient quantity to meet the boiling temperature requirement shall be used when laboratory altitude dictates. A commercial multi-functional water treatment material should be used in the coolant to minimize corrosion and mineral scale that can alter heat transfer and rating results.

8.1.1 Water shall be understood to mean reagent water conforming to Type IV, Specification D 1193. (**Warning**—Ethylene glycol based antifreeze is poisonous and may be harmful or fatal if inhaled or swallowed. See Annex A1.)

8.2 *Engine Crankcase Lubricating Oil*—An SAE 30 viscosity grade oil meeting the current API service classification for spark-ignition engines shall be used. It shall contain a detergent additive and have a kinematic viscosity from 9.3 to 12.5 mm² per s (cSt) at 100°C (212°F) and a viscosity index of not less than 85. Oils containing viscosity index improvers shall not be used. Multigraded oils shall not be used. (**Warning**—Lubricating oil is combustible and its vapor is harmful. See Annex A1.)

8.3 *Primary Reference Fuels*,¹¹ *isooctane* and normal heptane classified as reference fuel grade shall meet the specifications that follow: (**Warning**—PRF is flammable and its vapors are harmful. Vapors may cause flash fire. See Annex A1.)

8.3.1 *Isooctane* (2,2,4-trimethylpentane) shall be no less than 99.75 % by volume pure, contain no more than 0.10 % by volume *n*-heptane, and contain no more than 0.5 mg/L (0.002 g/U.S. gal) of lead.¹² (**Warning**—*Isooctane* is flammable and its vapors are harmful. Vapors may cause flash fire. See Annex A1.)

8.3.2 *n*-heptane shall be no less than 99.75 % by volume pure, contain no more than 0.10 % by volume *isooctane*, and contain no more than 0.5 mg/L (0.002 g/U.S. gal) of lead.¹² (**Warning**—*n*-heptane is flammable and its vapors are harmful. Vapors may cause flash fire. See Annex A1.)

8.3.3 80 octane PRF blend¹³ prepared using reference fuel grade *isooctane* and *n*-heptane shall contain 80 ± 0.1 % by volume *isooctane*.¹⁴ (**Warning**—80 octane PRF is flammable and its vapors are harmful. Vapors may cause flash fire. See Annex A1.)

8.3.4 Refer to Annex A5 for octane numbers of various blends of 80 octane PRF and either *n*-heptane (see Table A5.1) or *isooctane* (see Table A5.2).

8.4 *Dilute Tetraethyllead*,¹⁵ (commonly referred to as TEL Dilute Volume Basis) is a prepared solution of aviation mix tetraethyllead antiknock compound in a hydrocarbon diluent of 70 % (V/V) xylene, 30 % (V/V) *n*-heptane. (**Warning**—Dilute tetraethyllead is poisonous and flammable. It may be harmful or fatal if inhaled, swallowed, or absorbed through the skin. May cause flash fire. See Annex A1.)

8.4.1 The fluid shall contain 18.23 ± 0.05 % (m/m) tetraethyllead and have a relative density 15.6/15.6°C (60/60°F) of 0.957 to 0.967. The typical composition of the fluid, excluding the tetraethyllead, is as follows:

Ingredient	Typical Concentration, % (m/m)
Ethylene dibromide (scavenger)	10.6
Diluent:	
xylene	52.5
<i>n</i> -heptane	17.8
Dye, antioxidant and inerts	0.87

8.4.2 Add dilute tetraethyllead, in mL quantities, to a 400-mL volume of *isooctane* to prepare PRF blends used for ratings over 100 O.N. The composition of the dilute fluid is such that when 2.0 mL are added to 400 mL of *isooctane*, the blend shall contain the equivalent of 2.0 mL of lead/U.S. gal (0.56 g of lead/L).^{9,16}

8.4.3 Refer to Annex A5 for octane numbers of blends of tetraethyllead *isooctane* (see Table A5.3).

8.5 *Toluene, Reference Fuel Grade*^{9,17} shall be no less than 99.5 % by volume pure. Peroxide number shall not exceed 5 mg per kg (ppm). Water content shall not exceed 200 mg per kg.¹⁸ (**Warning**—Toluene is flammable and its vapors are harmful. Vapors may cause flash fire. See Annex A1.)

8.5.1 Antioxidant shall be added by the supplier at a treat rate suitable for good long term stability as empirically determined with the assistance of the antioxidant supplier.

¹³ 80 O.N. PRF are currently available from Chevron Phillips Chemical Company LP, 1301 McKinney, Suite 2130, Houston, TX 77010-3030 or Haltermann GmbH, Schopenstehl 15, 20095 Hamburg, Germany.

¹⁴ The supplier verifies that the blend contains by volume, 80 % *isooctane*, 20 % *n*-heptane using capillary gas chromatography and analytical calculations.

¹⁵ Dilute tetraethyllead is available from Ethyl Corporation, 330 S. Fourth St., Richmond, VA 23219-4304; or from The Associated Octel Company, Ltd., 23 Berkeley Square, London, England W1X 6DT.

¹⁶ The sole source of supply of premixed PRF blends of *isooctane* containing specific amounts of tetraethyllead known to the committee at this time is Chevron Phillips Chemical Company LP, 1301 McKinney, Suite 2130, Houston, TX 77010-3030.

¹⁷ The sole source of supply of toluene, reference fuel grade known to the committee at this time is Chevron Phillips Chemical Company LP, 1301 McKinney, Suite 2130, Houston, TX 77010-3030.

¹⁸ Toluene purity is determined by subtracting the sum of the hydrocarbon impurities and water content from 100 %. Determine the hydrocarbon impurities by Test Method D 2360. Determine water content by Test Method D 1744. Peroxide Number shall be determined in accordance with Test Method D 3703.

¹⁰ Refer to *Industrial Ventilation Manual*, published by the American Conference of Governmental Industrial Hygienists, Cincinnati, OH.

¹¹ Primary Reference Fuels are currently available from Chevron Phillips Chemical Company LP, 1301 McKinney, Suite 2130, Houston, TX 77010-3030 or Haltermann GmbH, Schopenstehl 15, 20095 Hamburg, Germany.

¹² Hydrocarbon composition shall be determined in accordance with Test Method D 2268. Lead contamination shall be determined in accordance with IP 224/02.

8.6 Check Fuels are in-house typical spark-ignition engine fuels having selected O.N. values, low volatility, and good long term stability. (**Warning**—Check Fuel is flammable and its vapors are harmful. Vapors may cause flash fire. See Annex A1.)

9. Sampling

9.1 Samples shall be collected in accordance with Practices D 4057, D 4177, and D 5842.

9.2 *Sample Temperature*—Samples shall be cooled to a temperature of 2 to 10°C (35 to 50°F), in the container in which they are received, before the container is opened.

9.3 *Protection from Light*—Collect and store sample fuels in an opaque container, such as a dark brown glass bottle, metal can, or a minimally reactive plastic container to minimize exposure to UV emissions from sources such as sunlight or fluorescent lamps.

10. Basic Engine and Instrument Settings and Standard Operating Conditions

10.1 *Installation of Engine Equipment and Instrumentation*—Installation of the engine and instrumentation requires placement of the engine on a suitable foundation and hook-up of all utilities. Engineering and technical support for this function is required, and the user shall be responsible to comply with all local and national codes and installation requirements.

10.1.1 Proper operation of the CFR engine requires assembly of a number of engine components and adjustment of a series of engine variables to prescribed specifications. Some of these settings are established by component specifications, others are established at the time of engine assembly or after overhaul, and still others are engine running conditions that must be observed or determined by the operator during the testing process.

10.2 *Conditions Based on Component Specifications:*

10.2.1 *Engine Speed*—900 ± 9 rpm, when the engine is firing, with a maximum variation of 9 rpm occurring during a rating. Engine speed, while firing, shall not be more than 3 rpm greater than when it is motoring without combustion.

10.2.2 *Indexing Flywheel to Top-Dead-Center (tdc)*—With the piston at the highest point of travel in the cylinder, set the flywheel pointer mark in alignment with the 0° mark on the flywheel in accordance with the instructions of the manufacturer.

10.2.3 *Valve Timing*—The engine uses a four-stroke cycle with two crankshaft revolutions for each complete combustion cycle. The two critical valve events are those that occur near tdc; intake valve opening and exhaust valve closing. See Annex A4 for camshaft timing and valve lift measurement procedures.

10.2.3.1 Intake valve opening shall occur 10.0 ± 2.5° after-top-dead-center (atdc) with closing at 34° after-bottom-dead-center (abdc) on one revolution of the crankshaft and flywheel.

10.2.3.2 Exhaust valve opening shall occur 40° before-bottom-dead-center (bbdc) on the second revolution of the crankshaft or flywheel, with closing at 15.0 ± 2.5° atdc on the next revolution of the crankshaft and flywheel.

TABLE 1 Carburetor Venturi Size for Various Laboratory Elevations

Altitude at Engine Location, ft (m)	Venturi Throat Diameter, in. (mm)	Typical Barometric Pressure Range, in. Hg (kPa)
Sea Level to 1600 (500)	5/16 (14.3)	31.0 to 28.0 (104.7 to 94.6)
1600 to 3300 (500 to 1000)	19/32 (15.1)	29.0 to 26.0 (97.9 to 87.8)
Higher than 3300 (1000)	3/4 (19.1)	27.0 and Less (91.2 and Less)

10.2.4 *Valve Lift*—Intake and exhaust cam lobe contours, while different in shape, shall have a contour rise of 0.246 to 0.250 in. (6.248 to 6.350 mm) from the base circle to the top of the lobe. The resulting valve lift shall be 0.238 ± 0.002 in. (6.045 ± 0.05 mm). See Annex A4 for camshaft timing and valve lift measurement procedures.

10.2.5 *Intake Valve Shroud*—The intake valve has a 180° shroud or protrusion just inside the valve face to direct the incoming fuel-air charge and increase the turbulence within the combustion chamber. This valve stem is drilled for a pin, which is restrained in a valve guide slot, to prevent the valve from rotating and thus maintain the direction of swirl. The valve shall be assembled in the cylinder, with the pin aligned in the valve guide, so that the shroud is toward the spark plug side of the combustion chamber and the swirl is directed in a counterclockwise direction if it could be observed from the top of the cylinder.

10.2.6 *Carburetor Venturi*—The venturi throat size is dependent on the altitude of the location where the CFR engine is installed. Select the proper venturi in accordance with Table 1.

10.2.6.1 For CFR engines located at altitudes close to where venturi size is designated to change, select whichever venturi size results in minimum bias when rating TSF blends in accordance with the requirements of Section 11.

10.3 *Assembly Settings and Operating Conditions:*

10.3.1 *Direction of Engine Rotation*—Clockwise rotation of the crankshaft when observed from the front of the engine.

10.3.2 *Valve Clearances:*

10.3.2.1 *Engine Stopped and Cold*—Clearance between the valve stem and valve rocker half-ball, set upon assembly before the engine is operated can provide the controlling engine running and hot clearance. With the engine at tdc on the compression stroke, the appropriate cold clearances are as follows:

Intake valve	0.004 in. (0.102 mm)
Exhaust valve	0.014 in. (0.356 mm)

These clearances should ensure that both valves have sufficient clearance to cause valve seating during engine warmup. The adjustable-length valve push-rods shall be set so that the valve rocker adjusting screws have adequate travel to permit the final clearance setting.

10.3.2.2 *Engine Running and Hot*—The clearance for both intake and exhaust valves shall be set to 0.008 ± 0.001 in. (0.20 ± 0.025 mm), measured under standard operating conditions with the engine running at equilibrium conditions on a 90 O.N. PRF blend.

10.3.3 *Oil Pressure*—172 to 207 kPa (25 to 30 psi). See Annex A4, for the procedure to adjust crankcase lubricating oil pressure.

10.3.4 *Oil Temperature*— $57 \pm 8^{\circ}\text{C}$ ($135 \pm 15^{\circ}\text{F}$).

10.3.5 *Cylinder Jacket Coolant Temperature*— $100 \pm 1.5^{\circ}\text{C}$ ($212 \pm 3^{\circ}\text{F}$) constant within $\pm 0.5^{\circ}\text{C}$ ($\pm 1^{\circ}\text{F}$) during a rating.

10.3.6 *Intake Air Temperature*— $38 \pm 2.8^{\circ}\text{C}$ ($100 \pm 5^{\circ}\text{F}$).

10.3.7 *Intake Mixture Temperature*— $149 \pm 1^{\circ}\text{C}$ ($300 \pm 2^{\circ}\text{F}$) maintained within 1°C ($\pm 2^{\circ}\text{F}$) during a rating. If intake MIXT tuning is used to qualify the engine as fit-for-use, the temperature selected shall be between 141°C (285°F) and 163°C (325°F) and this temperature shall then be maintained within $\pm 1^{\circ}\text{C}$ ($\pm 2^{\circ}\text{F}$) during a rating.

10.3.7.1 The intake MIXT required to qualify the engine in each TSF blend O.N. range shall also be used for rating all sample fuels in that O.N. range during an operating period.

10.3.8 *Intake Air Humidity*—0.00356 to 0.00712 kg water per kg (25 to 50 grains of water per lb) of dry air.

10.3.9 *Cylinder Jacket Coolant Level:*

10.3.9.1 *Engine Stopped and Cold*—Treated water/coolant added to the cooling condenser: Cylinder jacket to a level just observable in the bottom of the condenser sight glass will typically provide the controlling engine running and hot operating level.

10.3.9.2 *Engine Running and Hot*—Coolant level in the condenser sight glass shall be within ± 1 cm (± 0.4 in.) of the LEVEL HOT mark on the coolant condenser.

10.3.10 *Engine Crankcase Lubricating Oil Level:*

10.3.10.1 *Engine Stopped and Cold*—Oil added to the crankcase so that the level is near the top of the sight glass will typically provide the controlling engine running and hot operating level.

10.3.10.2 *Engine Running and Hot*—Oil level shall be approximately mid-position in the crankcase oil sight glass.

10.3.11 *Crankcase Internal Pressure*—As measured by a gage or manometer connected to an opening to the inside of the crankcase through a snubber orifice to minimize pulsations, the pressure shall be less than zero (a vacuum) and is typically from 25 to 150 mm (1 to 6 in.) of water less than atmospheric pressure. Vacuum shall not exceed 255 mm (10 in.) of water.

10.3.12 *Exhaust Back Pressure*—As measured by a gage or manometer connected to an opening in the exhaust surge tank or main exhaust stack through a snubber orifice to minimize pulsations, the static pressure should be as low as possible, but shall not create a vacuum nor exceed 255 mm (10 in.) of water differential in excess of atmospheric pressure.

10.3.13 *Exhaust and Crankcase Breather System Resonance*—The exhaust and crankcase breather piping systems shall have internal volumes and be of such length that gas resonance does not result. See Appendix X2 for a suitable procedure to determine if resonance exists.

10.3.14 *Belt Tension*—The belts connecting the flywheel to the absorption motor shall be tightened, after an initial break-in, so that with the engine stopped, a 2.25-kg (5-lb) weight suspended from one belt halfway between the flywheel and motor pulley shall depress the belt approximately 12.5 mm (0.5 in.).

10.3.15 *Basic Rocker Arm Carrier Adjustment:*

10.3.15.1 *Basic Rocker-Arm Carrier Support Setting*—Each rocker arm carrier support shall be threaded into the cylinder so

TABLE 2 Variation in Spark Timing As Cylinder Height is Changed

Cylinder Height Digital Counter Reading (Uncompensated)	Cylinder Height Dial Indicator Reading (Uncompensated)	Spark Timing, °btdc
264	0.825	26
337	0.773	25
410	0.721	24
484	0.669	23
556	0.617	22
630	0.565	21
704	0.513	20
777	0.461	19
851	0.408	18
925	0.356	17
998	0.304	16
1072	0.252	15
1145	0.200	14

that the distance between the machined surface of the cylinder and the underside of the fork is 31 mm (1 1/2 in.).

10.3.15.2 *Basic Rocker Arm Carrier Setting*—With the cylinder positioned so that the distance between the underside of the cylinder and the top of the clamping sleeve is approximately 160 mm (5/8 in.), the rocker arm carrier shall be set horizontal before tightening the bolts that fasten the long carrier support to the clamping sleeve.

10.3.15.3 *Basic Rocker Arm Setting*—With the engine on tdc on the compression stroke, and the rocker arm carrier set at the basic setting, set the valve adjusting screw to approximately the mid-position in each rocker arm. Then adjust the length of the push rods so that the rocker arms shall be in the horizontal position.

10.3.16 *Basic Spark Setting*— 26° btdc at a critical cylinder height, uncompensated for barometric pressure and indicated as a digital counter reading of 264 or a dial indicator reading of 0.825 in.

10.3.16.1 The digital timing indicator currently supplied with CFR engine units, or the graduated spark quadrant formerly supplied, shall be in proper working order and calibrated so that the time of ignition is correctly displayed with reference to the engine crankshaft.

10.3.16.2 *Basic Ignition Timer Control Arm Setting*—Adjust and set the length of the ignition control rod so that the centerline of the ignition control arm shall be horizontal at the specified cylinder height uncompensated for barometric pressure.

10.3.16.3 *Ignition Timer Basic Transducer to Rotor Vane Gap Setting*—0.08 to 0.13 mm (0.003 to 0.005 in.).

10.3.16.4 *Basic Spark Setting*—With the engine running and firing, position the ignition timer in the ignition timer control arm so that ignition occurs at 26° btdc as displayed on the digital timing indicator or spark quadrant. Tighten the control arm knurled clamping screw.

10.3.16.5 *Automatic Change Spark Timing Adjustment*—As cylinder height is adjusted during the determination of O.N., the spark timing is automatically changed and shall provide the characteristic given in Table 2.

10.3.17 *Spark Plug Gap*— 0.51 ± 0.13 mm (0.020 ± 0.005 in.).

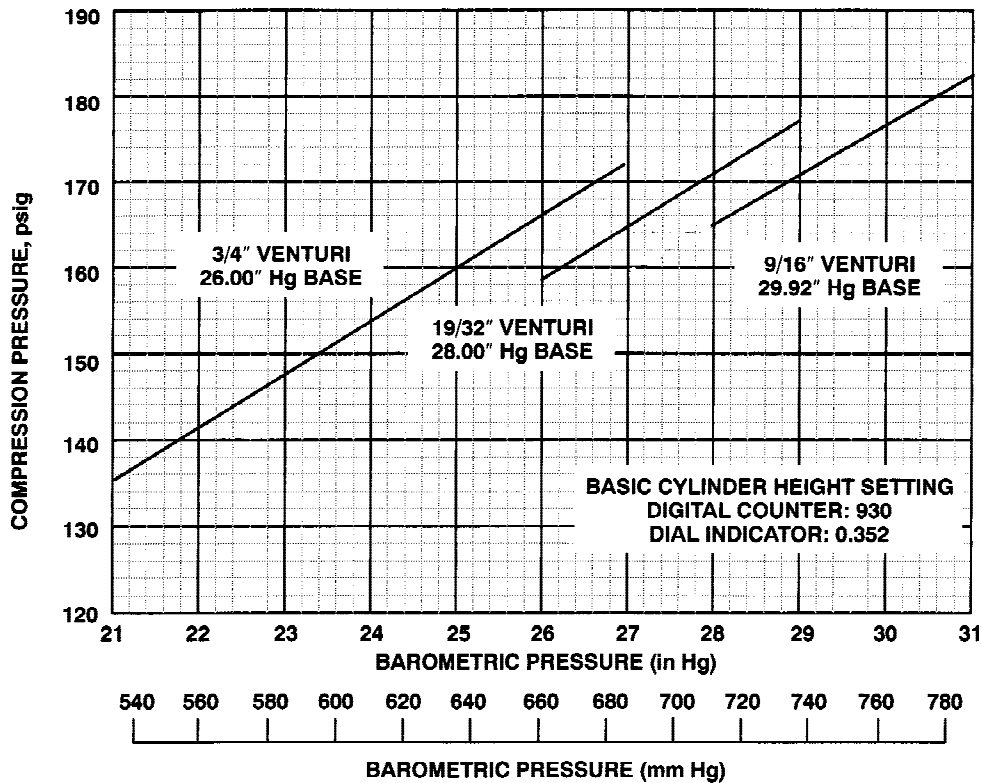

FIG. 2 Actual Compression Pressure for Setting Cylinder Height

10.3.18 *Basic Cylinder Height Setting*—Thoroughly warm up the engine under essentially standard operating conditions. Shut the unit down, and check that the ignition is turned off and fuel cannot enter the combustion chamber. Install a calibrated compression pressure gage assembly on the engine, motor the engine, and adjust the cylinder height so that the unit produces the basic compression pressure prescribed by the relationships of Fig. 2, for the appropriate carburetor venturi and the prevailing barometric pressure.

10.3.18.1 Index the cylinder height measurement device(s) to the appropriate value uncompensated for barometric pressure, as follows:

Digital Counter Reading of 930
Dial Indicator Reading of 0.352 in.

10.3.18.2 Refer to Annex A4 for a detailed cylinder height indexing procedure.

10.3.19 *Fuel-Air Ratio*—The fuel-air ratio (mixture proportion) for each sample fuel and PRF involved in the determination of an O.N. result shall be that which maximizes the K.I.

10.3.19.1 Fuel-air ratio is a function of the effective fuel level in the vertical jet of the standard carburetor assembly and is typically indicated as the fuel level in the appropriate carburetor sight glass.

10.3.19.2 The fuel level that produces maximum K.I. shall be from 0.7 to 1.7 in., referenced to the centerline of the venturi. If necessary, change the carburetor horizontal jet size (or equivalent restrictive orifice device) to satisfy the fuel level requirement.

10.3.20 *Carburetor Cooling*—Circulate coolant through the coolant passages of the carburetor whenever there is evidence

of premature vaporization in the fuel delivery passages. Release of hydrocarbon vapors from the sample fuel can result in uneven engine operation or erratic K.I. reading and is usually indicated by bubble formation or abnormal fluctuation of the fuel level in the sight glass.

10.3.20.1 *Coolant*—Water or a water/antifreeze mixture.

10.3.20.2 *Coolant Temperature*—The liquid coolant delivered to the carburetor coolant exchangers shall be cold enough to prevent excessive vaporization but not colder than 0.6°C (33°F) or warmer than 10°C (50°F).¹⁹

10.3.21 *Instrumentation:*

10.3.21.1 *Knockmeter Reading Limits*—The operational range for K.I. readings on the knockmeter shall be from 20 to 80. K.I. is a nonlinear characteristic below 20 and the knockmeter has the potential to be nonlinear above 80.

10.3.21.2 *Detonation Meter Spread and Time Constant Settings*—Optimize these variables to maximize spread commensurate with reasonable K.I. signal stability. Refer to Procedure sections and Annex A4 for further details.

10.3.21.3 *Knockmeter Needle Mechanical Zero Adjustment*—With the detonation meter power switch in the OFF position, and the meter switch in the ZERO position, set the knockmeter needle to zero using the adjusting screw provided on the knockmeter face.

10.3.21.4 *Detonation Meter Zero Adjustment*—With the detonation meter power switch in the ON position, the meter

¹⁹ Supporting data have been filed at ASTM International Headquarters and may be obtained by requesting Research Report RR: D02-1006.

TABLE 3 TSF Blend O.N._{ARV}, Untuned Rating Tolerances and Sample Fuel Octane Number Range of Use^A

TSF Blend M.O.N. ARV	Untuned Rating Tolerance	TSF Blend Composition, vol %			Use for Sample Fuel M.O.N. Range
		Toluene	Isooctane	Heptane	
81.5 ^B	±0.3	74	0	26	79.6–83.5
85.2 ^B	±0.3	74	5	21	83.2–87.1
88.7 ^B	±0.3	74	10	16	86.8–90.8
92.6 ^C	±0.4	74	15	11	90.5–94.7

^A Request Research Reports RR:D02-1208 and RR:D02-1354 for M.O.N. accepted reference value (ARV) data.

^B M.O.N. accepted reference values determined by TCD93 worldwide program in 1993.

^C M.O.N. accepted reference values determined by National Exchange Group in 1986.

switch in the ZERO position, the time constant switch on 3, and the meter reading and spread controls in their nominal operating positions, set the needle of the knockmeter to read zero using the detonation meter zero adjusting screw, which is to the left of the meter switch on the detonation meter and covered by a knurled cap.

11. Engine Standardization

11.1 *Unit Compliance*—Operate the properly commissioned knock test unit at temperature equilibrium and in compliance with the basic engine and instrument settings and standard operating conditions prescribed for this test method.

11.1.1 Operate the engine on fuel for approximately 1 h to ensure that all critical variables are stable. During the final 10 min of this warm-up period, operate the engine at a typical K.I. level.

11.2 *Fit-for-Use Qualification for Each Operating Period:*

11.2.1 Every sample fuel O.N. determination shall be performed using an engine that has been qualified as fit-for-use by rating the appropriate TSF blend.

11.2.2 Qualify the engine using the appropriate TSF blends in accordance with the following conditions:

11.2.2.1 At least once during each 12 h period of rating.

11.2.2.2 After an engine has been shut down for more than 2 h.

11.2.2.3 After an engine has been operated at non-knocking conditions for more than 2 h.

11.2.2.4 After a barometric pressure change of more than 0.68 kPa (0.2 in. Hg) from that reading made at the time of the previous TSF blend rating for the specific O.N. range.

11.2.3 When either bracketing procedure is utilized to determine the TSF blend rating, establish standard K.I. using a PRF blend whose whole O.N. is closest to that of the O.N. accepted reference value of the selected TSF blend.

11.2.4 When either bracketing procedure is utilized to determine the TSF blend rating, set the cylinder height, compensated for the prevailing barometric pressure, to the guide table value for the O.N._{ARV} of the selected TSF blend.

11.2.5 When the compression ratio procedure is utilized to determine the TSF blend rating, first establish standard K.I. using the PRF blend whose whole O.N. is closest to that of the O.N._{ARV} of the selected TSF blend.

11.3 *Fit-for-Use Procedure 79.8 to 94.5 O.N.:*

11.3.1 Select the appropriate TSF blend(s) from Table 3 that

TABLE 4 TSF Blend O.N._{ARV}, Rating Tolerances and Sample Fuel Octane Number Range of Use^A

TSF Blend M.O.N. ARV	Rating Tolerance	TSF Blend Composition, vol %			Use for Sample Fuel M.O.N. Range
		Toluene	Isooctane	Heptane	
58.0	±1.1	50	0	50	Below 62.3
66.9	±1.1	58	0	42	62.2–71.0
74.8	±1.0	66	0	34	70.7–76.7
78.2	±1.0	70	0	30	76.4–79.9
...
96.6	±1.2	74	20	6	94.4–98.4
99.8 ^B	±0.9	74	24	2	98.1–100.0
100.8	±1.3	74	26	0	Above 100.0

^A Request Research Report RR:D02-1208 for M.O.N. accepted reference value data.

^B M.O.N. accepted reference value determined by the National Exchange Group in 1986. M.O.N. accepted reference value for all other blends determined by the National Exchange Group and Institute of Petroleum in 1988/1989.

are applicable for the O.N.s of the sample fuel ratings tested or to be tested during the operating period.

11.3.2 Rate the TSF blend using the standard intake MIXT of 149°C (300°F).

11.3.2.1 If the engine standardization during the last operating period required MIXT tuning to be fit-for-use and maintenance has not taken place, it is permissible to start fit-for-use testing for a new operating period using approximately the same MIXT tuning adjustment applied for the previous operating period.

11.3.3 If the untuned TSF blend rating is within the untuned rating tolerances of Table 3 for that TSF blend, the engine is fit for use to rate sample fuels within the applicable O.N. range. Intake MIXT tuning is not required.

11.3.4 If the untuned TSF blend rating is more than 0.1 O.N. from the O.N._{ARV} in Table 3 for that TSF blend, it is permissible to adjust the intake MIXT slightly to obtain the O.N._{ARV} for that specific TSF blend.

11.3.5 If the untuned TSF blend rating is outside the untuned rating tolerance of Table 3, adjust the intake MIXT, within prescribed limits, to obtain the O.N._{ARV} for that specific TSF blend.

11.3.5.1 The tuned intake MIXT shall be no lower than 141°C (285°F) nor higher than 163°C (325°F).

NOTE 1—A TSF blend rating change of 0.1 O.N. requires an intake mixture temperature adjustment of approximately 1°C (2°F). Increasing the temperature decreases the O.N.

11.3.5.2 If the temperature tuned TSF blend rating is within ±0.1 O.N. of the O.N._{ARV} in Table 3, the engine is fit for use to rate sample fuels within the applicable O.N. range.

11.3.5.3 If the temperature tuned TSF blend rating is more than ±0.1 O.N. from the O.N._{ARV} in Table 3, the engine shall not be used for rating sample fuels having O.N. values within the applicable range until the cause is determined and corrected.

11.4 *Fit-for-Use Procedure—Below 79.8 and Above 94.5 O.N.:*

11.4.1 Select the appropriate TSF blend(s) from Table 4 that are applicable for the O.N. values of the sample fuel ratings tested or to be tested during the operating period.

11.4.2 The rating tolerances of Table 4 are determined by multiplying the standard deviation of the data that established

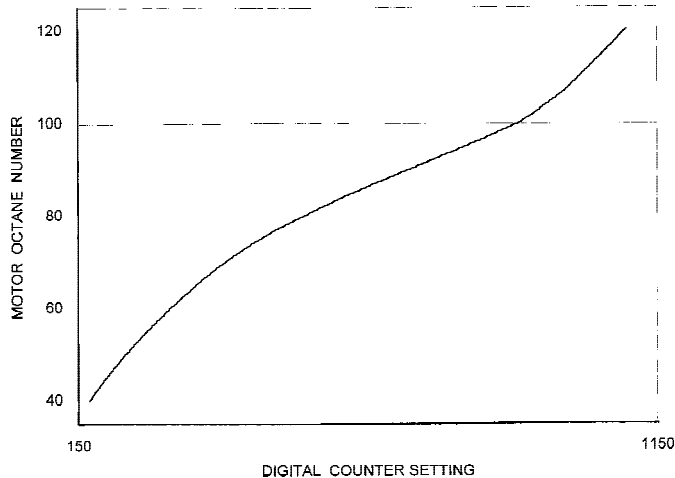

FIG. 3 Motor O.N. Versus Digital Counter Reading Characteristic

the $O.N._{ARV}$ of the TSF blend and a statistical tolerance limit factor K for normal distributions. Using the standard deviation values for the TSF blend data sets of 100 or more values and $K = 1.5$, it is estimated that in the long run, in 19 cases out of 20, at least 87 % of the test engines would rate the TSF blend within the rating tolerances listed in Table 4.

11.4.3 Rate the TSF blend using the standard intake MIXT of 149°C (300°F). Temperature tuning is not permitted for these O.N. levels.

11.4.4 If the TSF blend rating is within the rating tolerance, the engine is fit for use to rate sample fuels having O.N. values within the applicable range for that TSF blend.

11.4.5 If the TSF blend rating is outside the rating tolerance, conduct a comprehensive examination to determine the cause and required corrections. It is expected that some engines will rate outside the rating tolerance, at one or more of the O.N. levels, under standard operating conditions. Control records or charts of these TSF blend ratings can be helpful to demonstrate the ongoing performance characteristic of the unit.

11.5 Checking Performance on Check Fuels:

11.5.1 While engine standardization is dependent solely on TSF blend determinations, further rating using Check Fuels can provide additional credibility. Regular testing of Check Fuels and the use of standard quality control charting provide the means to document the overall effectiveness of the engine and operating personnel.

11.5.1.1 Test one or more Check Fuels.

11.5.1.2 Compare the octane rating obtained for the Check Fuel to the Check Fuel $O.N._{ARV}$.

11.5.1.3 Update the selected quality control charts to be maintained for the specific engine.

11.5.1.4 Interpret the performance depicted on the control charts in a timely manner so that investigation and corrective action can be taken if either a bias begins to develop or the variability of the engine begins to depreciate.

12. Test Variable Characteristics

12.1 *Cylinder Height Relationship to Octane Number*—Cylinder height, an indication of C.R., has a significant effect on fuels and their knocking characteristics. Every fuel has a critical C.R. at which knock begins to occur. As C.R. is

increased above this critical threshold, the degree of knock, or severity of knock, increases. The Motor method of test compares sample fuels to PRF blends at a selected knock level termed standard K.I. Guide tables of cylinder height versus O.N. have been empirically determined using PRF blends.²⁰ They are based on the concept that the K.I. at all O.N. values is constant as detected by the knock measuring instrumentation. Because this test method utilizes three different carburetor venturi sizes, tables specific to each venturi size have been established. Fig. 3 illustrates the slightly nonlinear relationship between Motor O.N. and cylinder height expressed as digital counter reading. Specific guide tables in terms of both digital counter reading and dial indicator reading for each of the three carburetor venturi sizes are in Annex A6 (see Table A6.1 and Table A6.8).

12.2 *Barometric Pressure Compensation of Cylinder Height*—O.N. values determined by this test method are referenced to standard barometric pressure of 760 mm (29.92 in.) of Hg. Changes in barometric pressure affect the level of knock because the density of the air consumed by the engine is altered. To compensate for a prevailing barometric pressure that is different from standard, the cylinder height is offset so that the K.I. will match that of an engine at standard barometric pressure. For lower than standard barometric pressure conditions, the cylinder height is changed to increase the engine C.R. and thus the knocking level. For higher than standard barometric pressure conditions, the cylinder height is changed to lower C.R. The changes in either digital counter reading or dial indicator reading to compensate for barometric pressure are listed in Annex A6 (see Tables A6.9 and A6.10).

12.2.1 *Digital Counter Applications*—The digital counter has two indicating counters. The top counter is directly connected to the worm shaft, which rotates the worm wheel that raises or lowers the cylinder in the clamping sleeve. It is the uncompensated digital counter reading. The lower counter can be disengaged from the upper counter for the purpose of off-setting its reading and thus establish the differential or compensation for prevailing barometric pressure. With the differential set, the two counters can be engaged to move together with the lower counter indicating the measure of cylinder height compensated to standard barometric pressure.

12.2.1.1 Digital counter readings decrease as cylinder height is raised and increase as cylinder height is lowered.

12.2.1.2 To index the digital counter unit, position the selector knob to any setting other than 1, change the cylinder height in the proper direction to compensate for the prevailing barometric pressure as given in Annex A6 (see Tables A6.9 and A6.10) so that the lower indicating counter is offset from the upper indicating counter by the amount of the compensation.

12.2.1.3 For barometric pressures lower than 760 mm (29.92 in.) of Hg, the lower indicating counter shall be less than the upper counter. For barometric pressures higher than 760 mm (29.92 in.) of Hg, the lower indicating counter shall be higher than the upper counter.

²⁰ Detonation meter guide tables were generated by setting the cylinder height to the value for the former bouncing pin instrumentation value at 85 O.N. and then using that K.I. as the reference for determining the cylinder height required for PRF blends over the range from 40 to 100 O.N.

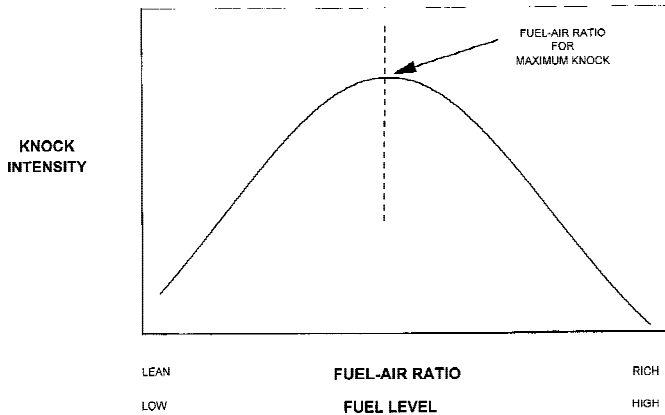

FIG. 4 Typical Effect of Fuel-Air Ratio on Knock Intensity

12.2.1.4 After adjusting to the correct counter readings, reposition the selector knob to 1 so that both indicating counters change when cylinder height changes are made. Check that the proper differential prevails as changes in cylinder height are made.

12.2.1.5 The lower indicating counter represents the measure of cylinder height at standard barometric pressure and is utilized for all comparisons with the values in the guide tables.

12.2.2 *Dial Indicator Applications*—The dial indicator is installed in a bracket on the side of the cylinder clamping sleeve so that the movable spindle contacts an anvil screw, positioned in a bracket mounted on the cylinder. As the cylinder is raised or lowered, the dial indicator reading measures the cylinder height in thousandths of an inch of travel. When indexed, the dial indicator reading is a measure of cylinder height for engines operating at standard barometric pressure. If the prevailing barometric pressure is other than 760 mm (29.92 in.) of Hg, correct the actual dial indicator reading so that it is compensated to standard barometric pressure. Compensated dial indicator readings apply whenever the reading is pertinent during the rating of sample fuels or when calibrating the engine using PRF blends.

12.2.2.1 Dial indicator readings decrease as cylinder height is lowered and increase as cylinder height is raised.

12.3 *Engine Calibration at the Guide Table Cylinder Height*—Calibrate the engine to produce standard K.I. at an O.N. level where sample fuels are expected to rate.

12.3.1 Prepare a PRF blend of the selected O.N. and introduce it to the engine.

12.3.2 Set the cylinder height to the appropriate guide table value (compensated for barometric pressure) for the O.N. of the PRF blend.

12.3.3 Determine the fuel level for maximum K.I.

12.3.4 Adjust the meter reading dial of the detonation meter so that the knockmeter reading is 50 ± 2 divisions.

12.4 *Fuel-Air Ratio Characteristic*—With the engine operating at a cylinder height that causes knock, variation of the fuel-air mixture has a characteristic effect, typical for all fuels. The peaking or maximizing knock characteristic is illustrated in Fig. 4. This test method specifies that each sample fuel and

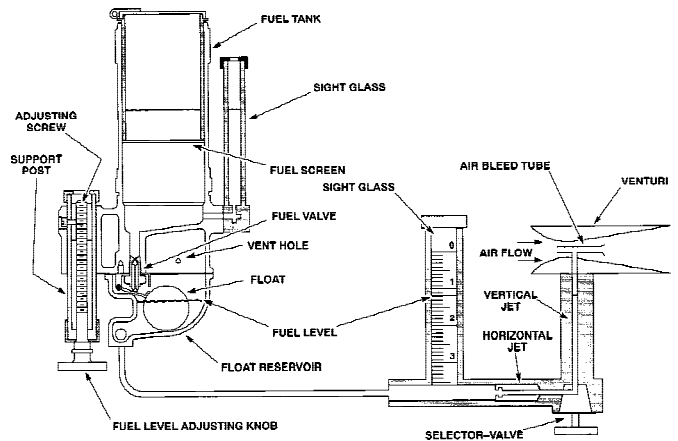

- Air flow through venturi is constant
- Raising fuel level richens F/A mixture
- Fuel level for maximum K.I. depends on horizontal jet size and fuel level
- Fuel level for maximum K.I. must be between 0.7 and 1.7
- Larger hole size in horizontal jet will lower maximum K.I. fuel level.

FIG. 5 CFR Engine Carburetor Assembly

PRF shall be operated at the mixture condition that produces the maximum K.I. The CFR engine carburetor, utilizing a single vertical jet, provides a simple means to monitor a measure of fuel-air ratio using a sight glass that indicates the fuel level in the vertical jet. Fig. 5 illustrates the relationships of the components. Low fuel levels relate to lean mixtures and higher levels to rich mixtures. Fuel level changes are made to determine the level that produces the maximum knocking condition. To maintain good fuel vaporization, a restrictive orifice or horizontal jet is utilized so that the maximum knock condition occurs for fuel levels between 0.7 and 1.7 in. referenced to the centerline of the carburetor venturi. The mechanics for varying the fuel mixture can be accomplished using various approaches.

12.4.1 *Fixed Horizontal Jet–Variable Fuel Level System*—Fuel level adjustments are made by raising or lowering the float reservoir in incremental steps. Selection of a horizontal jet having the appropriate hole size establishes the fuel level at which a typical sample fuel achieves maximum knock.

12.4.2 *Fixed Fuel Level–Variable Orifice System*—A fuel reservoir, in which the fuel can be maintained at a prescribed constant level, supplies an adjustable orifice (special long-tapered needle valve) used in place of the horizontal jet. Fuel mixture is changed by adjustment of the needle valve. Typically, the constant fuel level selected is near the 1.0 level, which satisfies the fuel level specification and also provides good fuel vaporization.

12.4.3 *Dynamic or Falling Level System*—A fuel reservoir, filled to a higher level than that required for maximum K.I., delivers fuel through either a fixed bore or adjustable horizontal jet. With the engine firing, the fuel level falls as fuel is consumed. Fuel level changes automatically at a specifically selected constant rate that is established by the cross-sectional

area of the fuel reservoir and associated sight glass assembly. Maximum K.I. is recorded as the fuel level passes through the critical level.

PROCEDURE A

13. Bracketing—Equilibrium Fuel Level

13.1 Check that all engine operating conditions are in compliance and equilibrated with the engine running on a typical fuel at approximately standard K.I.

13.2 Perform engine fit-for-use testing utilizing a TSF blend applicable for the O.N. range in which sample fuels are expected to rate. If TSF blend temperature tuning is to be used, determine the proper intake MIXT required. Perform this rating in the same manner described below for a sample fuel except that the TSF blend shall be rated without carburetor cooling.

13.3 Establish standard K.I. by engine calibration using a PRF blend having an O.N. close to that of the sample fuels to be rated.

13.3.1 Set the cylinder height to the barometric pressure compensated value for the O.N. of the selected PRF.

13.3.2 Determine the fuel level for maximum K.I. and then adjust the detonation meter METER READING dial to produce a knockmeter reading of 50 ± 2 divisions.

13.3.3 Check that detonation meter SPREAD is maximized commensurate with satisfactory knockmeter stability.

13.3.4 Detonation meter spread set at 12 to 14 K.I. divisions per O.N. at the 90 O.N. level will typically provide suitably optimized spread settings for the range 80 to 103 O.N. without resetting. Refer to Annex A4.

13.4 Sample Fuel:

13.4.1 Introduce the sample fuel to the carburetor, purge the fuel system, and if applicable, the sight glass and float reservoir by opening and then closing the sight glass drain valve several times and observing that there are no bubbles in the clear plastic tubing between the float reservoir and the sight glass. (**Warning**—Sample fuel is extremely flammable and its vapors are harmful if inhaled. Vapors may cause flash fire. See Annex A1.)

13.4.2 Operate the engine on sample fuel.

13.4.3 Adjust the cylinder height to cause a mid-scale knockmeter reading.

13.4.4 Determine the fuel level for maximum K.I. One approach is to first lower the fuel level (float reservoir assembly) and then raise it in small increments (0.1 sight glass divisions or less) until the knockmeter reading peaks and begins to fall off. Reset the float reservoir to the fuel level that produces the maximum knockmeter reading.

13.4.5 Adjust the cylinder height so that the knockmeter reading is 50 ± 2 divisions.

13.4.6 Record the knockmeter reading.

13.4.7 Observe the cylinder height reading, compensated to standard barometric pressure, and using the appropriate guide table, determine the estimated O.N. of the fuel sample.

13.5 Reference Fuel No. 1:

13.5.1 Prepare a fresh batch of a PRF blend that has an O.N. estimated to be close to that of the sample fuel.

TABLE 5 Maximum Permissible Bracketing PRF O.N. Differences

O.N. Range of Sample Fuel	Maximum Permissible O.N. Difference of PRF Blends
40 to 72	4.0
72 to 80	2.4
80 to 100	2.0
100.0 to 100.7	Use only 100.0 and 100.7 O.N. PRF blends
100.7 to 101.3	Use only 100.7 and 101.3 O.N. PRF blends
101.3 to 102.5	Use only 101.3 and 102.5 O.N. PRF blends
102.5 to 103.5	Use only 102.5 and 103.5 O.N. PRF blends
103.5 to 108.6	Use PRF blends 0.2 mL TEL/gal apart
108.6 to 115.5	Use PRF blends 0.5 mL TEL/gal apart
115.5 to 120.3	Use PRF blends 1.0 mL TEL/gal apart

13.5.2 Introduce Reference Fuel No. 1 to the engine and, if applicable, purge the fuel lines in the same manner as noted for the sample fuel.

13.5.3 Position the fuel-selector valve to operate the engine on Reference Fuel No. 1 and perform the step-wise adjustments required for determining the fuel level for maximum K.I.

13.5.4 Record the equilibrium knockmeter reading for Reference Fuel No. 1.

13.6 Reference Fuel No. 2:

13.6.1 Select another PRF blend that can be expected to result in a knockmeter reading that causes the readings for the two reference fuels to bracket that of the sample fuel.

13.6.2 The maximum permissible difference between the two reference fuels is dependent on the O.N. of the sample fuel. Refer to Table 5.

13.6.3 Prepare a fresh batch of the second PRF blend.

13.6.4 Introduce Reference Fuel No. 2 to the engine and, if applicable, purge the fuel lines in the same manner as noted for the sample fuel.

13.6.5 Position the fuel-selector valve to operate the engine on Reference Fuel No. 2 and perform the required step-wise adjustments for determining the fuel level for maximum K.I.

13.6.6 If the knockmeter reading for the sample fuel is bracketed by those of the two PRF blends, continue the test; otherwise try another PRF blend(s) until the bracketing requirement is satisfied.

13.6.7 Record the equilibrium knockmeter reading for Reference Fuel No. 2.

13.7 Repeat Readings:

13.7.1 Perform the necessary steps to obtain repeat knockmeter readings on the sample fuel, Reference Fuel No. 2, and finally Reference Fuel No. 1. For each fuel, be certain that the fuel level used is that for maximum K.I. and allow operation to reach equilibrium before recording the knockmeter readings. The fuel switching for the complete rating shall be as illustrated in Fig. 6.

13.7.2 Refer to Section 16 for detailed interpolation and calculation procedure.

13.7.3 The two knockmeter readings for the sample fuel and two for each of the PRF blends constitute a rating provided (1) the difference between the rating calculated from the first and second series of readings is no greater than 0.3 O.N., and (2) the average of the sample fuel knockmeter readings is between 45 and 55.

13.7.4 If the first and second series of knockmeter readings do not meet the criteria, a third series of readings may be

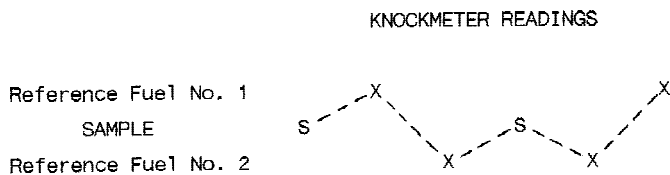

FIG. 6 Sample and Reference Fuel Reading Sequence

obtained. The fuel switching order for this set shall be sample fuel, Reference Fuel No. 1, and finally Reference Fuel No. 2. The second and third series of knockmeter readings shall then constitute a rating provided the difference between the rating calculated from the second and third series of readings is no greater than 0.3 O.N., and the average of the last two sample fuel knockmeter readings is between 45 and 55.

13.8 *Checking Guide Table Compliance:*

13.8.1 Check that the cylinder height, compensated for barometric pressure, used for the rating is within the prescribed limits of the applicable guide table value of cylinder height for the sample fuel O.N. At all O.N. levels, the digital counter reading shall be within ± 20 of the guide table value. The dial indicator reading shall be within ± 0.014 in. of the guide table value.

13.8.2 If the cylinder height of the sample fuel rating is outside the guide table limit, repeat the rating after readjustment of the detonation meter to obtain standard K.I. using a PRF blend whose O.N. is close to that of the sample fuel.

13.9 *Special Instructions for Sample Fuel Ratings Above 100 O.N.:*

13.9.1 Knock characteristics become more erratic and unstable at octane levels above 100 for several reasons. Careful attention to the setting and adjustment of all variables is required to ensure that the rating is representative of the sample fuel quality.

13.9.2 If the sample fuel rating will be above 100 O.N., it is necessary to establish standard K.I. using an *isooctane* plus TEL PRF blend before sample fuel testing can continue. This may require more than one trial to select the appropriate leaded PRF (one of the two that bracket the sample fuel) and proper cylinder height. It will also necessitate adjustment of the detonation meter METER READING dial to obtain a knockmeter reading of approximately 50 divisions. If the rating is between 100.0 and 100.7 O.N., use the *isooctane* plus 0.05 mL TEL PRF to establish standard K.I. At the higher O.N. levels, either of the specified leaded PRF blends for the particular O.N. range may be used for this purpose.

13.9.3 Refer to Table 5 when selecting the PRF blends for sample fuels that rate above 100 O.N. Use only the specified PRF pairs for sample fuels that rate in the O.N. ranges 100.0 to 100.7; 100.7 to 101.3; 101.3 to 102.5; and 102.5 to 103.5.

13.9.4 Check that detonation meter spread is maintained as large as possible despite the fact that knockmeter readings will vary considerably and make selection of an average reading tedious.

PROCEDURE B

14. Bracketing—Dynamic Fuel Level:

14.1 *Applicable O.N. Rating Range*—This procedure shall only apply for ratings within the range from 80 to 100 O.N.

14.2 Check that all engine operating conditions are in compliance and equilibrated with the engine running on a typical fuel at approximately standard K.I.

14.3 Perform engine fit-for-use testing utilizing a TSF blend applicable for the O.N. range in which sample fuels are expected to rate. If TSF blend temperature tuning is to be used, determine the proper intake MIXT required. Perform this rating in the same manner described below for a sample fuel except that the TSF blend shall be rated without carburetor cooling.

14.4 Establish standard K.I. by engine calibration using a PRF blend having an O.N. close to that of the sample fuels to be rated.

14.4.1 Set the cylinder height to the barometric pressure compensated value for the O.N. of the selected PRF.

14.4.2 Determine the fuel level for maximum K.I. and then adjust the detonation meter METER READING dial to produce a knockmeter reading of 50 ± 2 divisions.

14.4.3 Check that detonation meter SPREAD is maximized commensurate with satisfactory knockmeter stability.

14.4.4 Detonation meter spread set at 12 to 14 K.I. divisions per O.N. at the 90 O.N. level will typically provide suitably optimized spread settings for the range 80 to 100 O.N. without resetting. Refer to Annex A4.

14.5 *Sample Fuel:*

14.5.1 Introduce the sample fuel to an empty fuel reservoir. Purge the fuel line, sight glass, and fuel reservoir by opening and then closing the sight glass drain valve several times and observing that there are no bubbles in the clear plastic tubing between the fuel reservoir and the sight glass. Top off the level so that the fuel level is at approximately 0.4 in the sight glass. Where experience demonstrates the critical maximum K.I. occurs near a specific fuel level, filling to a level 0.3 above the typical level is acceptable. (**Warning**—Sample fuel is extremely flammable and its vapors are harmful if inhaled. Vapors may cause flash fire. See Annex A1.)

14.5.2 Position the fuel-selector valve to operate the engine on the sample fuel and observe that the fuel level begins to fall in the sight glass.

14.5.3 When applying this falling level technique, stop the sequence by switching to another fuel when the K.I. reading passes its maximum value and decreases approximately ten divisions. Closely monitor each falling fuel level sequence to ensure the engine is always supplied with fuel and that knocking conditions prevail for a high proportion of rating time to maintain operating temperature conditions.

14.5.4 If the K.I. reading changes significantly from mid-scale, adjust the cylinder height to bring the engine close to the standard K.I. condition.

NOTE 2—Proficiency in making this initial adjustment of cylinder height is achieved with experience.

14.5.5 Refill the fuel reservoir to the appropriate rich mixture sight glass level for each successive repetition of the trial-and-error process.

14.5.6 After the cylinder height is approximately determined, it may be necessary to make a final adjustment to ensure that (1) the fuel level for maximum K.I. occurs at a sight

glass level within the critical range from 0.7 to 1.7 in. and (2) the maximum K.I. reading is between 45 and 55 divisions.

14.5.7 Record the maximum K.I. reading, or if a K.I. recorder is being used, mark the trace to indicate the sample identification and highlight the maximum reading.

14.5.8 Observe the cylinder height reading, compensated to standard barometric pressure, and using the appropriate guide table, determine the estimated O.N. of the sample fuel.

14.6 *Reference Fuel No. 1:*

14.6.1 Prepare a fresh batch of a PRF blend that has an O.N. estimated to be close to that of the sample fuel.

14.6.2 Introduce Reference Fuel No. 1 to one of the unused fuel reservoirs, taking care to purge the fuel line, sight glass, and fuel reservoir in the same manner as noted for the sample fuel.

14.6.3 Position the fuel-selector valve to operate the engine on Reference Fuel No. 1 and record, or mark the recorder tracing, to indicate the maximum K.I. reading that occurs as the fuel level falls. Care shall be taken to observe that the maximum K.I. condition occurs at a fuel level within the specified 0.7 to 1.7 in. range.

14.7 *Reference Fuel No. 2:*

14.7.1 Select another PRF blend that can be expected to result in a maximum K.I. reading that causes the readings for the two reference fuels to bracket that of the sample fuel.

14.7.2 The maximum permissible difference between the two reference fuels is dependent on the O.N. of the sample fuel. Refer to Table 5.

14.7.3 Prepare a fresh batch of the selected PRF blend.

14.7.4 Introduce Reference Fuel No. 2 to one of the unused fuel reservoirs, taking care to purge the fuel line, sight glass, and fuel reservoir in the same manner as noted for the sample fuel.

14.7.5 Position the fuel-selector valve to operate the engine on Reference Fuel No. 2 and record, or mark the recorder tracing, to indicate the maximum K.I. reading which occurs as the fuel level falls. Care shall be taken to observe that the maximum K.I. condition occurs at a fuel level within the specified 0.7 to 1.7 in. range.

14.7.6 If the maximum K.I. reading for the sample fuel is bracketed by those of the two reference fuel blends, continue the rating; otherwise try another reference fuel blend(s) until the bracketing requirement is satisfied.

14.8 *Repeat Readings:*

14.8.1 Perform the necessary steps to obtain repeat K.I. readings on the sample fuel, Reference Fuel No. 2, and finally Reference Fuel No. 1. The fuel switching for the complete rating shall be as illustrated in Fig. 6.

14.8.2 Refer to Section 16 for detailed interpolation and calculation procedure.

14.8.3 The two maximum K.I. readings for the sample fuel and two for each of the PRF blends constitute a rating provided (1) the difference between the rating calculated from the first and second series of readings is no greater than 0.3 O.N., and the (2) average of the sample fuel K.I. readings is between 45 and 55.

14.8.4 If the first and second series of K.I. readings do not meet the criteria, a third series of readings may be obtained. The fuel switching order for this set shall be sample fuel, Reference Fuel No. 1, and finally Reference Fuel No. 2. The second and third series of maximum K.I. readings shall then constitute a rating provided the difference between the rating calculated from the second and third series of readings is no greater than 0.3 O.N., and the average of the last two sample fuel K.I. readings is between 45 and 55.

14.9 *Checking Guide Table Compliance:*

14.9.1 Check that the cylinder height, compensated for barometric pressure, used for the rating is within the prescribed limits of the applicable guide table value of cylinder height for the sample fuel O.N. At all O.N. levels, the digital counter reading shall be within ± 20 of the guide table value. The dial indicator reading shall be within ± 0.014 in. of the guide table value.

14.9.2 If the cylinder height of the sample fuel rating is outside the guide table limit, repeat the rating after readjustment of the detonation meter to obtain standard K.I. using a PRF blend whose O.N. is close to that of the sample fuel.

PROCEDURE C

15. Compression Ratio

15.1 *Cylinder Height Measurement*—This procedure shall be used only if the CFR engine is equipped with a digital counter for measurement of cylinder height in order to maximize the resolution of the measurement of this primary variable.

15.2 *Applicable O.N. Rating Range*—This procedure shall only apply for ratings within the range from 80 to 100 O.N.

15.3 Check that all engine operating conditions are in compliance and equilibrated with the engine running on a typical fuel at approximately standard K.I.

15.4 Perform engine fit-for-use testing utilizing a TSF blend applicable for the O.N. range in which sample fuels are expected to rate. If TSF blend temperature tuning is to be used, determine the proper intake MIXT required. This rating shall be performed in the same manner described below for a sample fuel, except that the TSF blend shall be rated without carburetor cooling.

15.5 Establish standard K.I. by engine calibration using a PRF blend having an O.N. close to that of the sample fuels to be rated.

15.5.1 Set the cylinder height to the barometric pressure compensated value for the O.N. of the selected PRF.

15.5.2 Determine the fuel level for maximum K.I., adjust the detonation meter METER READING dial to produce a knockmeter reading of 50 ± 2 divisions, and record this value.

15.5.3 Check that detonation meter SPREAD is maximized commensurate with satisfactory knockmeter stability.

15.5.4 Detonation meter spread set to 12 to 14 K.I. divisions per O.N. at the 90 O.N. level will typically provide suitably optimized spread settings for the range 80 to 100 O.N. without resetting. Refer to Annex A4.

15.6 *Sample Fuel:*

15.6.1 Introduce the sample fuel to the carburetor, purge the fuel system, and if applicable, the sight glass and float reservoir

by opening and then closing the sight glass drain valve several times and observing that there are no bubbles in the clear plastic tubing between the float reservoir and the sight glass. (**Warning**—Sample fuel is extremely flammable and its vapors are harmful if inhaled. Vapors may cause flash fire. See Annex A1.)

15.6.2 Operate the engine on sample fuel. If the engine knock changes drastically and results in either a very low or very high knockmeter reading, adjust cylinder height in the proper direction to reestablish a mid-scale knockmeter reading. This shift in O.N. level may require establishing standard K.I. with a different PRF blend whose O.N. can be estimated from the guide table for the cylinder height reading that has just been determined.

15.6.3 Adjust the cylinder height to cause a mid-scale knockmeter reading for the sample fuel.

15.6.4 Determine the fuel level for maximum K.I. One approach is to first lower the fuel level (float reservoir assembly) and then raise it in small increments (0.1 sight glass divisions or less) until the knockmeter reading peaks and begins to fall off. Reset the float reservoir to the fuel level that produces the maximum knockmeter reading.

15.6.5 Adjust the cylinder height so that the knockmeter reading is within ± 2 divisions of the standard K.I. reading recorded for the applicable PRF blend.

15.6.6 Allow equilibrium to occur, and if necessary, make any slight adjustment in cylinder height to obtain a valid standard K.I. reading. Do not extend the operating time beyond approximately 5 min as measured from the time at which the fuel level setting is finalized.

15.6.7 Upset engine equilibrium by opening the sight glass drain valve momentarily to cause the fuel level to fall and any trapped vapor bubbles to be removed. After closing the drain valve, observe that the knockmeter reading returns to the previous value. If the knockmeter reading does not repeat within ± 1 division, readjust the cylinder height to obtain the standard K.I. value for the applicable PRF blend and when equilibrium is achieved, repeat the fuel level upset check for repeatability of readings.

15.6.8 Read and record the compensated digital computer reading.

15.6.9 Convert the compensated digital counter reading to O.N. using the appropriate guide table.

15.7 Repeat Reading:

15.7.1 Check standard K.I. by operation on the PRF blend at the compensated digital counter reading for the O.N. of this blend. If the knockmeter reading is within ± 3 divisions of the original reading, record the value and switch back to the sample fuel. If the knockmeter reading is outside the ± 3 division limit, standard K.I. must be reset before again rating the sample fuel.

15.7.2 Check the sample fuel by adjusting the cylinder height so that the knockmeter reading is within ± 2 divisions of the standard K.I. reading recorded for the PRF blend and convert the compensated digital counter reading to O.N. using the appropriate guide table.

TABLE 6 Maximum Sample Fuel O.N. Difference from Calibration PRF

Sample Fuel O.N.	Maximum O.N. Difference Sample Fuel from PRF
80 to 90	2.0
90 to 100	1.0

15.7.3 The average of the two sample fuel O.N. results constitutes a rating provided the difference between them is no greater than 0.3 O.N.

15.8 Checking PRF Limit Compliance:

15.8.1 The average O.N. of the sample fuel is acceptable if it does not differ from the O.N. of the PRF used to establish standard K.I., by more than the value in Table 6.

15.8.2 When the O.N. difference between the sample fuel and the PRF exceeds the limits in Table 6, check standard K.I. using a new PRF whose O.N. is within the indicated limits. If the new PRF knockmeter reading, at the cylinder height for its O.N., is within 50 ± 1 divisions, the previously determined rating may be accepted. If not, perform a new engine calibration using the selected PRF and repeat the sample fuel rating.

15.9 Testing Sample Fuels of Similar O.N.:

15.9.1 If the O.N. values of several sample fuels are known to be similar, it is permissible to determine standard K.I. using an appropriate PRF, rate each of the sample fuels, and then check that the standard K.I. for the PRF is within ± 1 division of the initial value.

15.9.2 A check of standard K.I. shall, in any event, be made after every fourth sample fuel measurement.

16. Calculation of O.N.—Bracketing Procedures

16.1 Calculate the average knockmeter readings for the sample fuel and each of the PRF blends.

16.2 Calculate the O.N. by interpolation of these average knockmeter readings proportioned to the O.N. values of the bracketing PRF blends in accordance with the example shown in Fig. 7 and Eq 4:

$$O.N._S = O.N._{LRF} + \left(\frac{K.I._{LRF} - K.I._S}{K.I._{LRF} - K.I._{HRF}} \right) (O.N._{HRF} - O.N._{LRF}) \quad (4)$$

where:

- $O.N._S$ = octane number of the sample fuel,
- $O.N._{LRF}$ = octane number of the low PRF,
- $O.N._{HRF}$ = octane number of the high PRF,
- $K.I._S$ = knock intensity (knockmeter reading) of the sample fuel,
- $K.I._{LRF}$ = knock intensity of the low PRF, and
- $K.I._{HRF}$ = knock intensity of the high PRF.

17. Report

17.1 Motor O.N. of Spark-Ignition Engine Fuels:

17.1.1 Report the calculated bracketing procedure or the C.R. procedure result as Motor O.N.

17.1.1.1 For ratings below 72.0 O.N., report the value to the nearest integer. When the calculated O.N. ends with a 0.50, round off to the nearest even number; example, round 67.50 and 68.50 to 68 O.N.

17.1.1.2 For ratings from 72.0 through 103.5 O.N., report the value to the nearest tenth. When the calculated O.N. ends

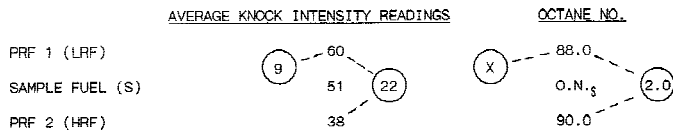

$$\begin{aligned}
 O.N._S &= O.N._{LRF} + \left(\frac{K.I._{LRF} - K.I._S}{K.I._{LRF} - K.I._{HRF}} \right) (O.N._{HRF} - O.N._{LRF}) \\
 &= 88.0 + \left(\frac{60 - 51}{60 - 38} \right) (90.0 - 88.0) \\
 O.N._S &= 88.0 + (0.409) (2.0) = \underline{88.82}
 \end{aligned}$$

NOTE—Circled values and the dashed lines represent the differences between the respective K.I. readings and O.N. values.

FIG. 7 Example of Octane Number Calculations

with exactly 5 in the second decimal place, round to the nearest even tenth number; example, round 89.55 and 89.65 to 89.6 O.N.

17.1.1.3 For ratings above 103.5 O.N., report the value to the nearest integer. When the calculated O.N. ends with a 0.50, round off to the nearest even number; example, round 105.50 and 106.50 to 106 O.N.

17.1.2 Report which procedure is used to determine the O.N.: bracketing—equilibrium fuel level, bracketing—dynamic fuel level, or compression ratio.

17.1.3 Report the engine room barometric pressure at the time of the rating.

17.1.4 Report the intake MIXT used.

17.2 Aviation Method Rating of Aviation Spark-Ignition Engine Fuel:

17.2.1 Report the calculated rating result as Motor O.N. rounded to the nearest tenth.

17.2.1.1 Report the engine room barometric pressure at the time of the rating.

17.2.1.2 Report the intake MIXT used.

17.2.2 Use the Motor O.N., rounded to the nearest tenth, and Table 7 to obtain the Aviation method rating. Round the converted value to the nearest tenth using the same rounding practice previously described.

17.2.2.1 Report Aviation method ratings that are 100.0 or less as O.N.

17.2.2.2 Report Aviation method ratings that are higher than 100.0 as performance number (P.N.).

18. Precision and Bias

18.1 Bracketing—Equilibrium Fuel Level Procedure A and C.R. Procedure C.²¹

18.1.1 80.0 to 90.0 Motor O.N. Range—The precision of this test method for Motor O.N.s between 80.0 and 90.0 based on statistical examination of interlaboratory test results by the bracketing—equilibrium fuel level or compression ratio procedures is as follows:

²¹ Supporting data (a listing of the data and the analyses used to establish the precision statements) have been filed at ASTM International Headquarters and may be obtained by requesting Research Report RR: D02-1383.

TABLE 7 Conversion of Motor O.N. to Aviation Method Rating^{A,B,C}

Motor Octane Number	0.0	0.2	0.4	0.6	0.8
75	73.59	73.81	74.04	74.27	74.49
76	74.72	74.95	75.17	75.40	75.63
77	75.85	76.08	76.30	76.53	76.75
78	76.98	77.20	77.43	77.65	77.88
79	78.10	78.33	78.55	78.77	79.00
80	79.22	79.44	79.67	79.89	80.11
81	80.33	80.55	80.78	81.00	81.22
82	81.44	81.66	81.88	82.10	82.32
83	82.55	82.77	82.99	83.21	83.43
84	83.65	83.86	84.08	84.30	84.52
85	84.74	84.96	85.18	85.40	85.61
86	85.83	86.05	86.27	86.48	86.70
87	86.92	87.13	87.35	87.57	87.78
88	88.00	88.22	88.43	88.65	88.86
89	89.08	89.29	89.51	89.72	89.94
90	90.15	90.37	90.58	90.79	91.01
91	91.22	91.43	91.65	91.86	92.07
92	92.29	92.50	92.71	92.92	93.13
93	93.35	93.56	93.77	93.98	94.19
94	94.40	94.61	94.82	95.04	95.25
95	95.46	95.67	95.88	96.09	96.29
96	96.50	96.71	96.92	97.13	97.34
97	97.55	97.76	97.96	98.17	98.38
98	98.57	98.74	98.91	99.08	99.25
99	99.43	99.60	99.77	99.95	100.54
100	101.07	101.60	102.14	102.67	103.21
101	103.74	104.27	104.81	105.34	105.88
102	106.41	106.94	107.48	108.01	108.55
103	109.08	109.61	110.15	110.68	111.22
104	111.75	112.28	112.82	113.35	113.89
105	114.42	114.95	115.49	116.02	116.56
106	117.09	117.62	118.16	118.69	119.23
107	119.76	120.29	120.83	121.36	121.90
108	122.43	122.96	123.50	124.03	124.57
109	125.10	125.63	126.17	126.70	127.24
110	127.77	128.30	128.84	129.37	129.91

^A This table converts Motor octane numbers to Aviation method ratings equivalent to those of now-discontinued Method D 614, Test for Knock Characteristics of Aviation Fuels by the Aviation Method.

^B Correlation information is given in RR:D02.69, "Aviation Gasoline Antiknock ASTM Methods D 614 and D 357." (Replaced by Test Method D 2700.)

^C Aviation ratings above the line are in terms of octane number and ratings below the line are in terms of performance number.

18.1.1.1 Repeatability—The difference between two test results, obtained on identical test samples under repeatability conditions would, in the long run, in the normal and correct operation of the test method, exceed 0.2 O.N. only in one case in twenty.

18.1.1.2 Reproducibility—The difference between two single and independent results obtained on identical test samples under reproducibility conditions would, in the long run, in the normal and correct operation of the test method, exceed 0.9 O.N. only in one case in twenty.

18.1.1.3 The above repeatability is based on the replicate O.N. results obtained by the ASTM Motor National Exchange Group (NEG) participating in cooperative testing programs from 1983 through 1987 and 1994. Between 80 and 90 Motor O.N., the repeatability standard deviation is 0.09, unaffected by octane level. This average standard deviation has been multiplied by 2.772 to obtain the limit value.

18.1.1.4 The above reproducibility is based on the combined NEG monthly sample testing program data from 1988 through 1994, the Institute of Petroleum monthly sample data

from 1988 through 1994, and the Institut Francais du Petrole monthly sample data from 1991 through 1994. The combination of the large number of sample sets and the fact that each sample fuel was tested by more than 30 laboratories, provides a comprehensive picture of the precision achievable using this test method. Analyzed graphically, the respective sample fuel standard deviations were plotted versus O.N. The variation in precision with respect to O.N. level, for the range of these data, is best expressed by a linear regression of the values. Between 80 and 90 Motor O.N., the reproducibility standard deviation is 0.34 unaffected by octane level. This average standard deviation has been multiplied by 2.772 to obtain the limit value.

18.1.1.5 Sample fuels containing oxygenate (alcohols or ethers), in the concentrations typical of commercial spark-ignition engine fuels, have been included in the exchange programs and the precision for these sample fuels is statistically indistinguishable from non-oxygenated fuels in the Motor O.N. range from 80.0 to 90.0.

18.1.1.6 The equivalence of this test method when performed at barometric pressures less than 94.6 kPa (28.0 in. of Hg) has not been determined. Reproducibility for the 80.0 to 90.0 O.N. range at altitude locations, based on ASTM Rocky Mountain Regional Group interlaboratory test results, would, in the long run, in the normal operation of the test method, exceed approximately 1.4 O.N. only in one case in twenty.

18.1.2 *Below 80.0 Motor O.N. Range:*

18.1.2.1 Precision cannot be stated for the range below 80.0 Motor O.N. because current data are not available.

18.1.3 *90 to 102.0 Motor O.N. Range:*

18.1.3.1 Precision cannot be stated for the 90.0 to 102.0 Motor O.N. range because sufficient current data are not available.

18.1.4 *102 to 103 Motor O.N. Range*—The precision of this test method at the 102 to 103 Motor O.N. level based on statistical examination of interlaboratory test results is as follows:

18.1.4.1 *Repeatability*—The difference between two test results, obtained on identical test samples under repeatability conditions would, in the long run, in the normal and correct operation of the test method, exceed 0.6 O.N. only in one case in twenty.

18.1.4.2 *Reproducibility*—The difference between two single and independent results obtained on identical test samples under reproducibility conditions would, in the long run, in the normal and correct operation of the test method, exceed 2.0 O.N. only in one case in twenty.

18.1.4.3 The above repeatability and reproducibility values are based on replicate O.N. results obtained by from 12 to 15 laboratories participating in the ASTM Aviation National Exchange Group (NEG) during the period from 1988 through 1994. The repeatability and reproducibility pooled variances for the 21 samples that rated within this range were determined. The resulting average standard deviations have been multiplied by 2.772 to obtain the respective limit values.

18.1.5 *Above 103.0 Motor O.N. Range:*

18.1.5.1 Precision cannot be stated for the range above 103.0 Motor O.N. because current data are not available.

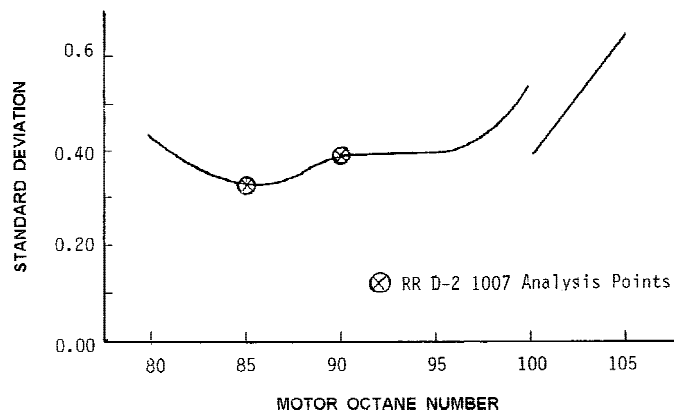

FIG. 8 Variation of Reproducibility Standard Deviation With Motor Octane Number

18.2 *Bracketing—Dynamic Fuel Level Procedure B:*

18.2.1 The amount of data for the bracketing—dynamic fuel level procedure is limited.²² The available information includes a statistical study involving single ratings by seven laboratories that comparatively tested four gasoline samples and three TSF blends, in the 80.0 to 90.0 Motor O.N. range, by both the bracketing dynamic fuel level procedure and the bracketing—equilibrium fuel level procedure. A second phase examined repeatability using duplicate bracketing—dynamic fuel level procedure ratings by each of four laboratories on eight sample fuels.

18.2.1.1 Repeatability of the bracketing—dynamic fuel level procedure is similar to that of the bracketing—equilibrium fuel level procedure as inferred from the statistical analysis of the limited duplicate ratings data set.

18.2.1.2 Reproducibility of the bracketing—dynamic fuel level procedure is indistinguishable from that of the bracketing—equilibrium fuel level procedure based on the statistical analysis of the limited data from the round-robin study.

18.3 *Standard Deviation:*

18.3.1 Examination of interlaboratory test results for Motor O.N. was initiated in 1933 with the formation of the National Exchange Group that regularly tests at least one sample per month. These historical data have demonstrated that the variability (standard deviation) of the test method changes with O.N. as shown in Fig. 8. The curve for this figure is based on ASTM National Exchange Group data from 1966 through 1987.

18.4 *Bias*—The procedures in this test method for Motor O.N. of spark-ignition engine fuel have no bias because the value of Motor O.N. can be defined only in terms of this test method.

19. **Keywords**

19.1 aviation rating; guide table; *isooctane*; knock intensity; motor octane number; *n*-heptane; spark-ignition engine fuel performance; toluene standardization fuel

²² Supporting data have been filed at ASTM International Headquarters and may be obtained by requesting Research Report RR: D02-1343.

ANNEXES

(Mandatory Information)

A1. HAZARDS INFORMATION

A1.1 Introduction

A1.1.1 In the performance of this test method there are hazards to personnel. These are indicated in the text. The classification of the hazard or Warning is noted with the appropriate key words of definition. For more detailed information regarding the hazards, refer to the appropriate Material Safety Data Sheet (MSDS) for each of the applicable substances to establish risks, proper handling, and safety precautions.

A1.2 (Warning—Combustible. Vapor Harmful.)

A1.2.1 *Applicable Substances:*

A1.2.1.1 Engine crankcase lubricating oil.

A1.3 (Warning—Flammable. Vapors are harmful if inhaled. Vapors may cause flash fire.)

A1.3.1 *Applicable Substances:*

A1.3.1.1 Aviation gasoline

A1.3.1.2 Aviation spark-ignition engine fuel

A1.3.1.3 80 octane PRF blend

A1.3.1.4 Check Fuel

A1.3.1.5 Fuel blend

A1.3.1.6 Isooctane

A1.3.1.7 Leaded isooctane PRF

A1.3.1.8 N-heptane

A1.3.1.9 Oxygenate

A1.3.1.10 PRF

A1.3.1.11 PRF blend

A1.3.1.12 Reference fuel

A1.3.1.13 Sample fuel

A1.3.1.14 Spark-ignition engine fuel

A1.3.1.15 TSF

A1.3.1.16 TSF blend

A1.3.1.17 Xylene

A1.4 (Warning—Poison. May be harmful or fatal if inhaled or swallowed.)

A1.4.1 *Applicable Substances:*

A1.4.1.1 Antifreeze mixture

A1.4.1.2 Aviation mix tetraethyllead antiknock compound

A1.4.1.3 Dilute tetraethyllead

A1.4.1.4 Glycol based antifreeze

A1.4.1.5 Halogenated refrigerant

A1.4.1.6 Halogenated solvents

A2. ENGINE EQUIPMENT DESCRIPTION AND SPECIFICATIONS

A2.1 Engine Equipment

A2.1.1 The single cylinder test engine for the determination of O.N. is manufactured as a complete unit by Waukesha Engine Division, Dresser Industries, Inc. and consists of both critical and noncritical equipment. The Waukesha Engine Division designation is Model CFR F-2 Motor Method Octane Rating Unit. Waukesha Engine Division Reference Numbers are included in parenthesis after all critical terms and, where appropriate, for non-critical items although these latter listings do not imply they are mandatory.

NOTE A2.1—The Waukesha Engine Division Reference Numbers are for the purpose of specifying components as applicable to this test method. These numbers are not to be used for purchasing parts from the supplier. Users must always refer to the part numbers listed in the current Waukesha Engine Division CFR Parts Catalog when ordering components.

A2.1.1.1 See Table A2.1 for General Rating Unit Characteristics and Information.

A2.1.1.2 See Table A2.2 for Engine Dimensions, Manufacturing Tolerances, and Replacement Limits.

TABLE A2.1 General Rating Unit Characteristics and Information

Item	Description
Test Engine	CFR F-2 Motor Method Octane Rating Unit with cast iron, box type crankcase with flywheel connected by V-belts to power absorption electrical motor for constant speed operation
Cylinder Type	Cast iron with flat combustion surface and integral coolant jacket
Compression Ratio	Adjustable 4:1 to 18:1 by cranked worm shaft and worm wheel drive assembly in cylinder clamping sleeve
Cylinder Bore (Diameter), in.	3.250 (Standard)
Stroke, in.	4.50
Displacement, cu in.	37.33

TABLE A2.1 *Continued*

Item	Description
Valve Mechanism	Open rocker assembly with linkage for constant valve clearance as C.R. changes
Intake Valve	Stellite faced, with 180° shroud
Exhaust Valve	Stellite faced, plain type without shroud
Piston	Cast iron, flat top
Piston Rings	
Top Compression Ring	1 chrome plated or ferrous, straight sided
Other Compression Rings	3 ferrous, straight sided
Oil Control	1 cast iron, one piece, slotted (Type 85)
Camshaft Overlap, degrees	5
Fuel System	
Carburetor	Single vertical jet and fuel flow control to permit adjustment of fuel-air ratio
Venturi Throat Diameter, in.	Dependent on installation altitude $\frac{3}{16}$; sea level to 500 m (1600 ft) $\frac{19}{32}$; 500 m to 1000 m (3300 ft) $\frac{3}{4}$; over 1000 m (3300 ft)
Ignition	Electronically triggered condenser discharge through coil to spark plug
Ignition Timing	Variable as cylinder height (C.R.) is changed
Intake Air Humidity	Controlled within specified limited range

TABLE A2.2 Engine Dimensions, Manufacturing Tolerances and Replacement Limits

Item	Basic Dimension	Manufacturing Tolerance	Replacement Limits
Crankcase:			
Oil passages in crankcase	Pass $\frac{1}{4}$ in. rod		
Crankshaft bearings:			
Front main:			
Journal diameter	3.00	2.9995 to 3.0000	...
Journal to bearing clearance	...	0.0035 to 0.0049	0.006 max
Rear main:			
Journal diameter	3.00	2.9995 to 3.0000	...
Journal to bearing clearance	...	0.0035 to 0.0049	0.006 max
Main bearing to case clearance (both)	...	0.0005 to 0.0020	...
Crankshaft end-play	...	0.006 to 0.008	0.010 max
Connecting rod bearing (big end):			
Crankshaft journal diameter	2.50	2.4995 to 2.5000	...
Journal to bearing clearance	...	0.0011 to 0.0036	0.005 max
End-play	...	0.008 to 0.014	0.016 max
Connecting rod bearing (piston pin end):			
Rod end to piston boss clearance	$\frac{1}{16}$ min
Piston pin to bushing clearance	...	0.0005 to 0.0010	0.015 max
Connecting rod alignment:			
	(1) Piston wall perpendicular to axis of journal within 0.003.		
	(2) Piston pin twist in length of big-end bearing within 0.002.		
	(3) Centerline of rod perpendicular to axis of bearings within 0.003.		
Camshaft bearings:			
Camshaft journal diameter:			
Front	...	1.7795 to 1.7805	...
Rear	...	1.2485 to 1.2495	...
Front journal to bearing clearance	...	0.0015 to 0.0030	0.004 max
Rear journal to bearing clearance	...	0.0020 to 0.0035	0.004 max
Bearing to case clearance (both)	...	0.0005 to 0.0020	...
End-play	...	0.002 to 0.005	0.007 max
Balancing shaft bearings:			
Balancing shaft journal diameter	...	1.748 to 1.749	...
Shaft to bearing clearance (both)	...	0.0015 to 0.0030	0.004 max
Bearing to case clearance (both)	...	0.0005 to 0.0020	...
End-play	...	0.002 to 0.006	0.010 max
Idler gear:			
Stub shaft diameter	...	0.9980 to 0.9985	...
Stub shaft to bearing clearance	...	0.0015 to 0.0030	0.004 max
End-play	...	0.002 to 0.004	0.008 max
Gear tooth backlash	...	0.002 to 0.004	0.006 max
Valve lifter guide clearance	...	0.0005 to 0.0020	0.003 max
Valve timing (based on 0.010 in. quieting ramp lift from base circle)			
Inlet valve opens	10° atdc \pm 2.5°		
Inlet valve closes	34° abdc		
Exhaust valve opens	40° bbdc		
Exhaust valve closes	15° atdc \pm 2.5°		
Flywheel:			
Side face run-out	...	0.005 max	0.007 max
Rim surface eccentricity	...	0.003 max	0.005 max

TABLE A2.2 *Continued*

Item	Basic Dimension	Manufacturing Tolerance	Replacement Limits
Piston:			
Piston diameters: ^A			
Top land	3.235 to 3.237		
Second through fifth lands	3.242 to 3.244		
Skirt	3.2465 to 3.2475		
Piston to cylinder clearances:			
Top land	...	0.013 to 0.016	...
Second through fifth lands	...	0.006 to 0.009	...
Skirt	...	0.0025 to 0.0045	0.0105 max
Ring to land clearances:			
Top	...	0.001 to 0.003	0.004
All others	...	0.001 to 0.0025	0.0035
Ring gap clearances:			
Compression rings	...	0.007 to 0.012	0.030 max
Oil ring	...	0.007 to 0.012	0.030 max
Piston pin diameter			
Pin to piston clearance	...	1.2495 to 1.2498	...
Pin to piston clearance	...	0.0002 to 0.0004	0.002
Piston pin retainers (Truarc)			
Free diameter after compression	1.340 min		
Piston pin hole alignment	...	0.001 max	0.0015
Standard cylinder: ^B			
Bore diameter	3.250	3.2500 to 3.2510	0.006 (over bore diameter)
Bore out of round	...	0.0005 max	0.0025
Bore taper	...	0.0005 max	...
Bore surface quality	...	10 to 20 microinch	scored
Bore surface hardness	...	196 to 269 Brinell	...
Rocker arm carrier pin clearances	...	0.0000 to 0.0007	0.0015 max
Rocker arms:			
Bearing shaft diameter	...	0.5003 to 0.5005	...
Ball seats	...	Smooth and fit ball	...
Valves, intake and exhaust:			
Stem diameter	0.3725	0.3725 to 0.3720	0.3705 min
Face angle, degrees	45
Concentricity, stem to face (run-out)	...	0.0015 max	0.0020 max
Valve shroud, intake only ^C	180°		
Valve guides:			
Internal diameter:			
Intake	...	0.3740 to 0.3750	0.3770 max
Exhaust	...	0.3750 to 0.3760	0.3785 max
Intake guide slot	Shall be parallel to centerline of valves within ±1°		
Guide projection above cylinder (both)	1.0
Valve guide to valve stem clearance:			
Intake	...	0.0015 to 0.0030	0.005 max
Exhaust	...	0.0025 to 0.0040	0.006 max
Valve seat inserts, intake and exhaust:			
Concentricity, seat to guide	...	0.0015 max	0.0015 max
Seat width	...	0.050 to 0.060	0.070 max
Face angle, dg ^D	45		...
Valve springs:			
Free length:			
Intake or exhaust (non-rotator type)	2.549	...	2.453 min
Exhaust (rotator type)	2.125	...	2.016 min
Cylinder clamping sleeve:			
Counterbore depth for worm wheel	...	2.750 to 2.755	...
Sleeve bore to cylinder external diameter clearance	...	0.001 to 0.005	0.006 max
Worm wheel:			
Thickness (between faces)	...	2.752 to 2.757	...
Wheel to sleeve base distance	0.003 recess to 0.007 protrusion	0.005 max recess	
Internal thread clearances on cylinder		turn freely	Loose fit
Worm shaft:			
End play:			
External thread to worm wheel	...	0.002 max	0.004 max
Shaft in clamping sleeve	shim adjustable	0.001 to 0.003	0.005 max
Intake mixture manifold:			
Thermometer placement:	Thermometer bulb centered in manifold bore		
Center of thermometer hole:			
From center axis of heater passage	1.875 ± 0.020		
From manifold outlet flange face	0.437 ± 0.020		
Dual blade heater element placement:	(1) Opening between blades directly opposite manifold outlet flange (2) Blades straight and parallel to each other, centrally located between manifold walls		

TABLE A2.2 *Continued*

Item	Basic Dimension	Manufacturing Tolerance	Replacement Limits
(3) Bottom of blades extend 1/8 to 1/4 in. below manifold outlet centerline.			

^A Oversize piston diameters are 0.010, 0.020 and 0.030 larger respectively.

^B Reboring cylinders + 0.010, + 0.020, or + 0.030 in. oversize is permitted but bore tolerance and other specifications shall apply.

^C Install intake valve with opening of shroud toward the pickup hole.

^D For interference angle approach, use face angle of 46 to 47°.

A2.2 Critical Equipment

A2.2.1 Critical engine components and primary assemblies that shall be used for this test method are listed. The bearings, gears, seals, covers, special fittings or hardware and gaskets manufactured by Waukesha Engine Division and applicable to each critical assembly shall also be considered critical.

A2.2.2 *Crankcase Assembly*—Model CFR-48 (109520) (see Fig. A2.1) specified to include the following major items:

A2.2.2.1 Crankshaft Assembly (109511).

A2.2.2.2 Piston Assembly (23204).

A2.2.2.3 Rings, Piston, Compression, Straight (106222-STR), 4 required.

NOTE A2.2—Ring, Piston, Compression, Straight, Chrome (106222-CHR). Use of a chrome ring in the top groove is optional with three compression rings (106222-STR) in the other three compression ring grooves.

A2.2.2.4 Ring, Piston, Oil (23505).

A2.2.2.5 Connecting Rod Assembly (111666).

A2.2.2.6 Camshaft (109583).

A2.2.2.7 Valve Lifter Assembly, two required (109519).

A2.2.2.8 Balancing Shaft, two required (109510).

A2.2.2.9 Counterweight for Balancing Shaft, two required (109565).

A2.2.2.10 Flywheel (109501), (applicable for 50 or 60 Hz units).

A2.2.2.11 Oil Pump Assembly (110150).

A2.2.2.12 Oil Suction Screen Assembly (109552).

A2.2.2.13 Oil Pressure Control Valve Assembly (109538).

A2.2.2.14 Crankcase Breather Assembly (110475).

A2.2.2.15 Stud Assembly, Crankcase to Cylinder Clamping Sleeve (B839, two required; B5764, two required; B364, one required).

A2.2.2.16 Stud Nuts, Cylinder Clamping Sleeve, five required (105361).

A2.2.3 *Cylinder Assembly*—(109355) (see Fig. A2.2) of cast iron with integral coolant passages, a basic bore diameter of 3.250 in., a flat-top combustion chamber surface, a precisely machined external barrel to act as a bearing surface for alignment of the cylinder in the associated clamping sleeve, an external threaded section on the lower external barrel skirt so the cylinder assembly can be screwed up and down in the clamping sleeve to provide a wide range of C.R., tapped holes for insertion of a spark plug and a detonation pickup, a keyway in the external barrel to ensure angular alignment of the cylinder in the clamping sleeve. The assembly is specified to include the following major items:

A2.2.3.1 Valve Seat Inserts, integral but replaceable, hardened, two required (105987-STD).

A2.2.3.2 Valve Guides, integral but replaceable, (23109-INT) one required, (23109-EXH), one required.

A2.2.3.3 Intake Valve, with 180° shroud (23436).

A2.2.3.4 Exhaust Valve (106625).

A2.2.3.5 Intake Valve Spring Assembly (G-806-4), including one Spring (43335), one Felt (B4680), one Retainer (106407), and two Tapers (106523).

A2.2.3.6 Exhaust Valve Spring Rotator Assembly (G-806-5), including one Spring (109659), one Felt (B4680), one Valve Rotator (110165), and two Tapers (109658).

A2.2.3.7 Valve Rocker Arm Subassembly (23272).

A2.2.4 *Cylinder Clamping Sleeve*—(G-830) of cast iron for installation on the engine crankcase to position, align and restrain the cylinder assembly with respect to the connecting rod and piston. The clamping sleeve internal bore surrounds the outer barrel of the cylinder and a split flange on the sleeve can be tightened by a cam actuated lever or screw. An associated worm wheel screws onto the threaded skirt of the cylinder barrel and is rotated by a worm shaft which can be either hand cranked or motor operated to raise or lower the cylinder barrel and vary engine compression ratio. The assembly is specified to include the following major items:

A2.2.4.1 Worm Wheel (23059).

A2.2.4.2 Worm Shaft Assembly (23073).

A2.2.4.3 Clamping Cam Assembly (109010).

A2.2.4.4 Springs, four required (B5268).

A2.2.4.5 Cylinder Guide Plate (23065) and associated Gaskets, one each required (106721 lower and B2544 upper).

A2.2.5 *Cylinder Coolant System Assembly*, specified to include the following major items:

A2.2.5.1 Condenser Body Assembly (109264), including condenser coil assembly, baffle tube and sight glass subassembly.

A2.2.5.2 Condenser Water Pipe Assembly (109131).

A2.2.5.3 Water Inlet Pipe Assembly (109418-ASM).

A2.2.6 *Inlet Air System Assembly*—(106601-ASM), specified to include the following major items:

A2.2.6.1 Ice Tower Assembly (106601).

A2.2.6.2 Ice Tower Tube, 6 in. O.D. (109497).

A2.2.6.3 Humidifier Tube, 6 in. O.D. (109495).

A2.2.6.4 Air Heater Plenum, 6 in. O.D. (110412).

A2.2.6.5 Inlet Air Heater (106583).

A2.2.6.6 Carburetor Inlet Elbow Assembly (106595).

A2.2.7 *Carburetor Components*—(G-814) specified to include the following major items:

A2.2.7.1 Carburetor Heat Shield (75738).

A2.2.7.2 Gasket (heat shield to cylinder or intake manifold), one required (109346).

A2.2.7.3 Gasket (carburetor body to heat shield), one required (109345).

A2.2.7.4 Carburetor Body (75960).

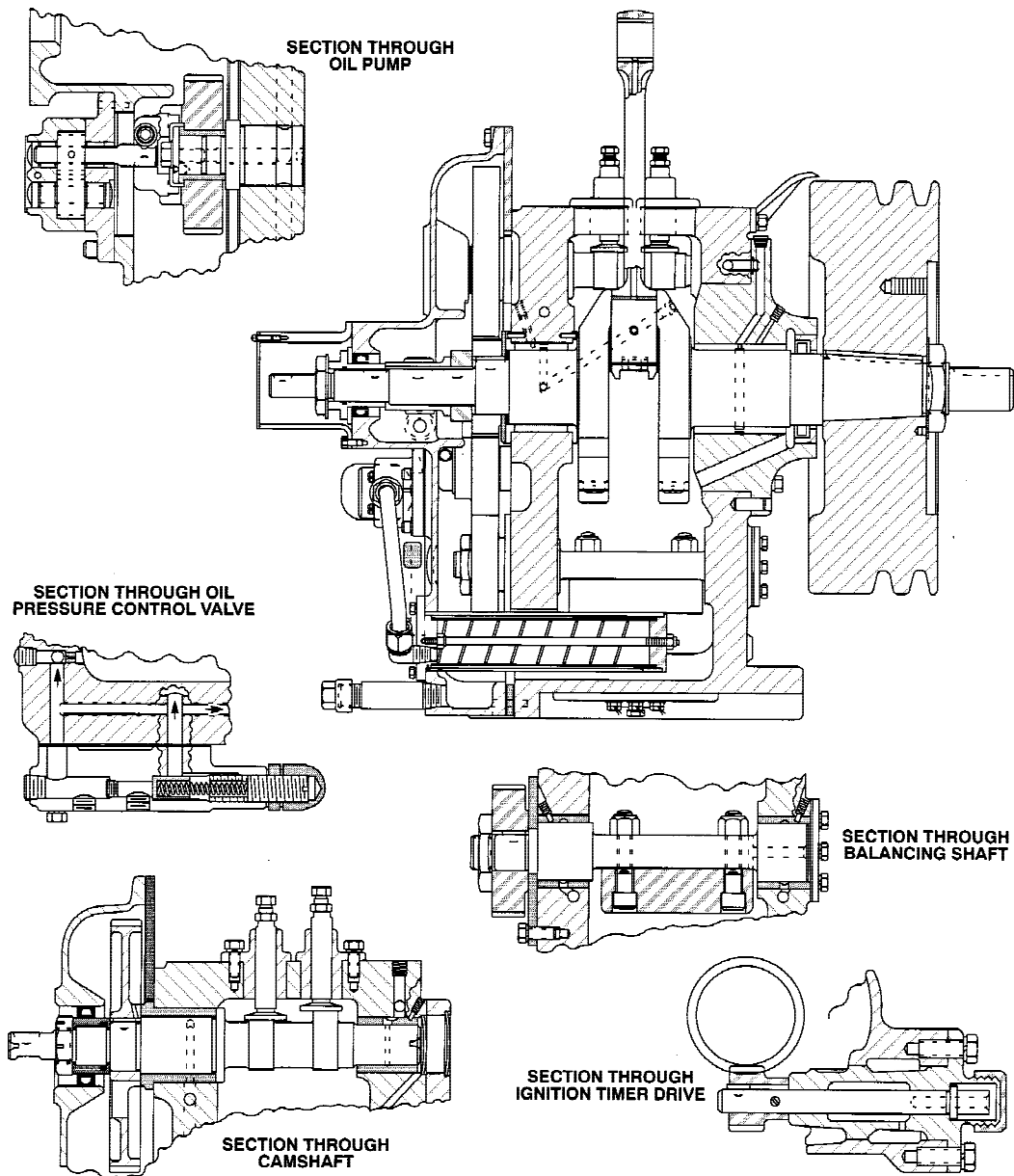

FIG. A2.1 CFR-48 Crankcase—Sectional Views

A2.2.7.5 Carburetor Venturi—Select the appropriate venturi on the basis of the altitude at which the engine is operating as follows:

Altitude at Engine Location, ft (m)	Venturi Throat Diameter, in. (mm)	Waukesha Reference No.
Sea Level to 1600 (500)	9/16 (14.3)	75984-9/16
1600 to 3300 (500 to 1000)	19/32 (15.1)	75984-19/32
Higher than 3300 (1000)	3/4 (19.1)	75984-3/4

A2.2.7.6 Carburetor Air Bleed Tube (75983).

A2.2.7.7 Carburetor Vertical Jet Tube Assembly (75985).

A2.2.8 Intake Mixture Manifold and Heater Assembly—(106748-ASM), specified to include the following major items:

A2.2.8.1 Intake Manifold (106747).

A2.2.8.2 Manifold Heater (106748), with manifold gasket (105991).

A2.2.9 Ignition System—Control unit, ignition coil, ignition timer unit, and spark plug to convert 115 V ac single phase power to the dc ignition voltage for proper firing of the spark plug in the engine cylinder and specified to include the following major items:

A2.2.9.1 Ignition Control Unit (111419).

A2.2.9.2 Ignition Timer Unit Assembly with trigger coil (111417-ASM).

A2.2.9.3 Ignition Coil (111418).

A2.2.9.4 Spark Plug, Champion D-16 (111460) with Rolled-Steel Gasket (110381).

NOTE A2.3—Champion D-16 Spark Plugs are available from commercial sources as well as Waukesha Engine Division.

A2.2.9.5 Ignition Cable Assembly, carbon core (166942).

A2.2.10 Ignition Control Assembly—(109847-ASM) specified to include the following major items:

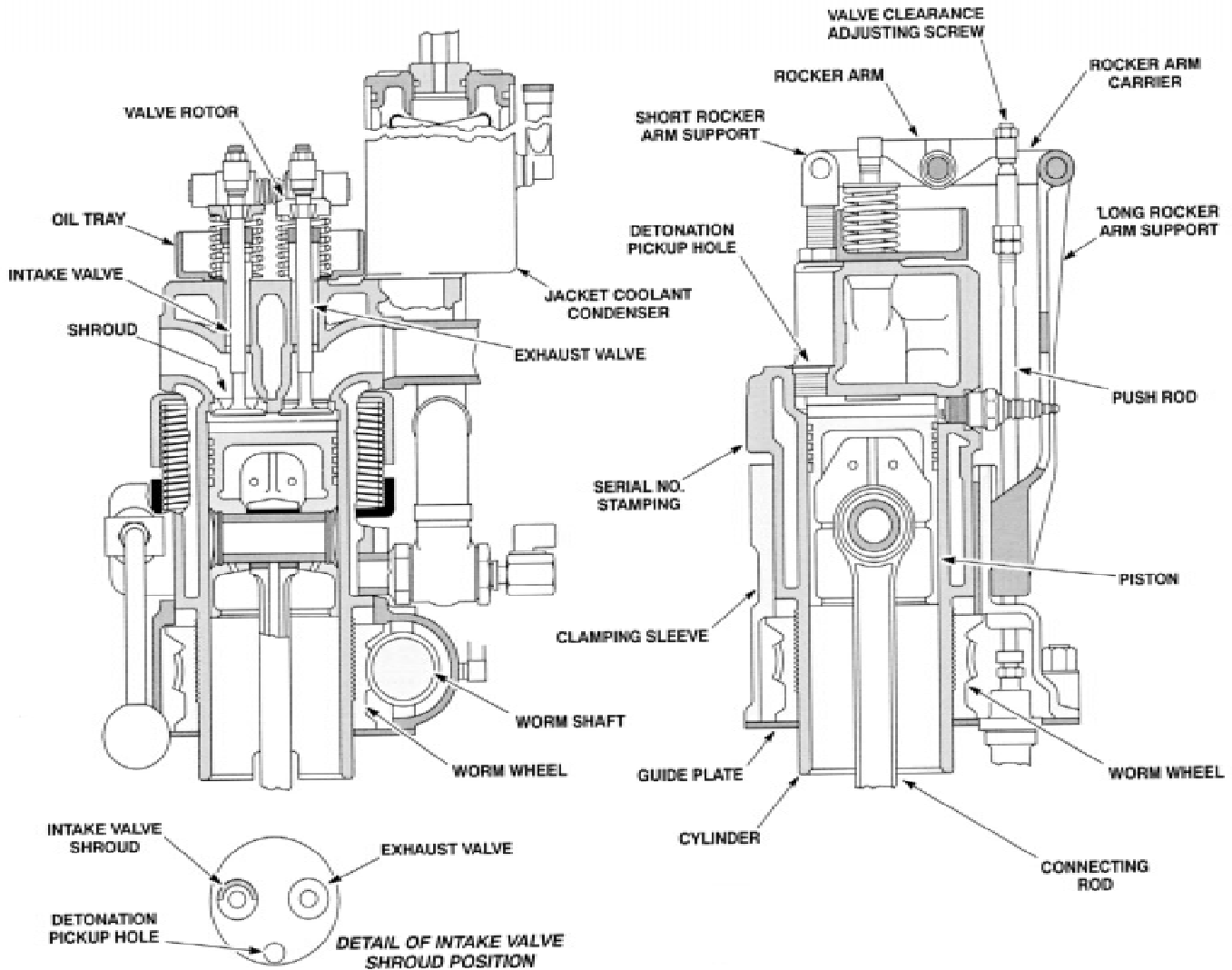

FIG. A2.2 Cylinder and Clamping Sleeve Assembly

A2.2.10.1 Ignition Control Bracket (109847), for installation on the engine cylinder.

A2.2.10.2 Ignition Control Rod Assembly (75509).

A2.2.10.3 Distributor Control Arm (109605).

A2.2.11 *Power Absorption Motor*—Reluctance-type, synchronous, single speed, electric motor for belt drive connection to the engine and capable of both starting the engine and absorbing the power developed when combustion is in process. Waukesha Engine Division is the sole supplier of this item in order to ensure meeting the required speed and load absorbing specifications. Part numbers are dependent on the three-phase electrical service voltage and frequency available at the site of unit installation.

A2.3 Equivalent Equipment

A2.3.1 *Low-Speed Crankcase Assembly*—This was the original model developed in 1933. Parts for this crankcase are no longer manufactured.

A2.3.2 *High-Speed Crankcase Assembly*—This model was the standard version manufactured from about 1939 through 1954. Parts for this crankcase are no longer manufactured.

A2.3.3 *Cylinder Assembly* (109355), which has, through operational wear, exceeded the basic bore diameter tolerance and has been successfully rebored to 0.010, 0.020, or 0.030 in. oversize.

A2.3.4 *Piston Assembly*, for use with rebored cylinder assemblies as follows:

A2.3.4.1 For 0.010 in. oversize cylinders (23204-1).

A2.3.4.2 For 0.020 in. oversize cylinders (23204-2).

A2.3.4.3 For 0.030 in. oversize cylinders (23204-3).

A2.3.5 *Ring, Piston, Compression, Straight*, for use with oversize piston assemblies as follows:

A2.3.5.1 For 0.010 in. oversize pistons (106222-STR1) or chrome (106222-CHR1).

A2.3.5.2 For 0.020 in. oversize pistons (106222-STR2) or chrome (106222-CHR2).

A2.3.5.3 For 0.030 in. oversize pistons (106222-STR3) or chrome (106222-CHR3).

A2.3.6 *Ring, Piston, Oil*, for use with oversize piston assemblies as follows:

A2.3.6.1 For 0.010 in. oversize pistons (23505-1).

A2.3.6.2 For 0.020 in. oversize pistons (23505-2).

A2.3.6.3 For 0.030 in. oversize pistons (23505-3).

A2.3.7 *Exhaust Valve Spring Assembly* (G-806-4), including one Spring (43335), one Felt (B4680), one Retainer (106407), and two Tapers (106523). This assembly is the same as the intake valve spring assembly and was the original and non-rotator type assembly for both intake and exhaust valve applications.

A2.3.8 *Motorized Compression Ratio Changer*, replacement equipment for the hand crank to reversibly rotate the worm shaft of the cylinder clamping sleeve assembly. The assembly is specified to include the following major items:

A2.3.8.1 Bracket Assembly (111240-ASM).

A2.3.8.2 Compression Ratio Changer Motor Assembly (111242)—Cranking rotation for these motor and gear drive assemblies is 48 rpm.

A2.3.8.3 Motor Shaft Coupler Assembly (110625-ASM).

A2.3.9 *Intake Air Refrigeration System Assembly*,²³

replacement equipment for the ice tower for dehumidification of air for engine combustion. This equipment shall deliver conditioned air to the 6 in. humidifier tube (109495) of the critical inlet air system assembly. (**Warning**—Mechanical refrigeration equipment may not be capable of adding water vapor to the conditioned air. If the air in the room where the engine is installed contains less than 25 grains of water per lb (0.00356 kg water per kg) of dry air, ratings can have a bias of approximately 0.05 O.N.)

A2.3.10 *Humidity Control System*,²⁴ replacement equipment for the complete inlet air system assembly for the conditioning of air for engine combustion. This system includes an air compressor that shall deliver 12 SCFM of clean, undried air at 60 to 100 psig (0.40 to 0.70 MPa) through a pressure regulator to a bubble tower so that conditioned air at atmospheric pressure is metered for release in an air hood positioned above the inlet air pipe to the engine carburetor. The conditioned air supply slightly exceeds that drawn into the engine inlet pipe for combustion and the excess simply spills from the air hood. The system is specified to include the following major assembly available from Waukesha Engine Division:

A2.3.10.1 Air Silencer Assembly (110470), with the Inlet Air Heater (106583).

A2.3.11 *Inlet Air System Components*:

A2.3.11.1 Air Surge Pipe Assembly (106616)—Original equipment, no longer manufactured, may be used instead of the Air Heater Plenum (110412).

A2.3.11.2 Carburetor Air Inlet Pipe, Straight (106684), replacement equipment for the carburetor inlet elbow assembly (106595).

A2.3.12 *Breaker Type Ignition System*—Units equipped with ignition power supply, breaker point distributor, and the ignition coil for this early type system are applicable. Parts for this type system are no longer available.

A2.4 Non-Critical Equipment and Specifications

A2.4.1 A number of components and devices are required to integrate the critical or equivalent equipment items into a complete working system or unit. Many of these are common hardware, tubing, fasteners, and electrical items potentially available from multiple sources. In some cases, however, selection of specific sizes or specification criteria are important to achieve the proper conditions for the knock testing equipment unit. Important criteria or specifications are included when applicable. In addition, if an item is available from Waukesha Engine Division as part of their standard supply, the Reference Number is given in parenthesis.

A2.4.2 *Foundation and Bedplate*:

A2.4.2.1 *Foundation*—Typically, in the form of a reinforced concrete block, site poured, the foundation should be approximately 700-mm wide, 1320-mm long, and a minimum of 380-mm high (28-in. wide, 53-in. long, and a minimum of 13-in. high). If the unit is placed on an industrial building floor of reinforced concrete approximately 200-mm (8-in.) thick, no special support for the foundation is required.

A2.4.2.2 *Bedplate* (27671)—Of cast iron, 24-in. wide, 48-in. long, and 4-in. high such that the engine and power absorption motor can be solidly mounted and aligned. In addition, this platform can be utilized for assembly of accessory electrical equipment, controls, instrumentation, and utility connections.

A2.4.3 *Heater for Crankcase*—(B3109) dual element, 1000 W maximum, surface mounting, flat, circular electrical heater.

A2.4.4 *Exhaust Discharge System Assembly*—Piping, with or without water cooling, suitable to discharge exhaust fumes from the combustion chamber to atmosphere, having a flexible connection to allow for engine cylinder up and down movement, and incorporating adequate volume and length to comply with the specified operating conditions for exhaust back pressure without resonance.

A2.4.4.1 *Surge Tank with Water Injection Spray Assembly* (109887), assembled with an exhaust manifold assembly (23242) is applicable and requires discharge and support piping as well as a water drain.

A2.4.4.2 Use of an exhaust manifold of rigid pipe connected to an exhaust stack by flexible hose and equipped with a water spray nozzle assembly to inject cooling water prior to the flexible hose is applicable. Packaged systems of this type are available from several engineering and support organizations.

A2.4.5 *Filter Assembly for Crankcase Oil*—(111345-ASM).

A2.4.6 *Sample Fuel and Reference Fuel Delivery Components*—Introduction of fuel to the carburetor vertical jet and a means to switch from one fuel to another may be accomplished in numerous ways as long as the flow of fuel through the carburetor permits the determination of the fuel-air ratio for maximum K.I. as dictated by any one of the test procedures. Typical assemblies are as follows:

²³ Available from Core Laboratories Refinery Systems, 19 Roszel Rd., Princeton, NJ 08452.

²⁴ Available from GEP Co., 2401 Marilyn Drive, Wilmington, DE 19803.

A2.4.6.1 *Carburetor Selector*—Valve Assembly—3 Bowl (75961) or 4 Bowl (105333) designed to fasten to the carburetor vertical jet flange for delivery of liquid fuel into the jet through a rotary selector-valve supplied by either three or four sources of fuel. The selector-valve assembly incorporates stanchions that project outward like spokes. Each stanchion houses an interchangeable horizontal jet, supports a vertically mounted sight glass tube to indicate the level of the particular fuel, includes an inlet opening at the base of the sight glass for connection to the source container for that particular fuel, and has a drain connection for fast disposal of unwanted fuel from both the source container and the selector-valve passages.

A2.4.6.2 *Fuel Tank*—Float Reservoir Assembly, three or four required (75964-ASM) applicable when using testing procedures that depend on establishing and maintaining the fuel level for the maximum K.I. condition. Each assembly includes a fuel tank sight glass assembly and a check valve at the bottom of the tank operated by a float to establish a constant fuel level in the float reservoir. These assemblies are supported on carburetor posts integral with a bracket (bar) that is fastened to the carburetor body. A two-lead screw and nut assembly with adjusting knob is installed in the post and the fuel tank, float reservoir assembly fastens to the nut so that as the screw is rotated by the knob, the assembly is raised or lowered.

(1) *Fuel Tank, without cooling jacket* (75962-NC), is applicable for reference fuels and also for sample fuels that do not require chilling. A fuel tank with cooling jacket (75962-WC) is applicable for sample fuels only.

(2) *Float Reservoir (chamber), without cooling jacket* (75964-NC), is applicable for reference fuels and also for sample fuels that do not require chilling. A float reservoir (chamber), with cooling jacket (75964-WC) is applicable for sample fuels only.

A2.4.6.3 *Falling Level Reservoir Assembly*, apparatus for systems that depend on controlled change in fuel level to vary fuel-air ratio at a constant rate from a rich to lean mixture.

NOTE A2.4—Falling level reservoir assemblies are utilized for the bracketing—dynamic fuel level test procedure of this test method and by some online octane analyzer systems for application of Test Method D 2885.

(1) The cross sectional area of the reservoir determines the rate at which the fuel level falls. Within the range that establishes a fuel level for maximum K.I. in the carburetor vertical jet between 0.7 and 1.7 in. referenced to the centerline

of the carburetor venturi, the cross sectional area of the reservoir shall be constant and not less than 3830 mm² (5.9 in.²).

A2.4.6.4 *Spill Carburetor Reservoir Assembly*, applicable for systems that depend on delivering a continuous flow of sample fuel so that fuel in the vertical jet of the carburetor is maintained at a constant level located within the range from 0.7 to 1.7 in. referenced to the centerline of the carburetor venturi. This type of apparatus requires use of an adjustable delivery (horizontal) jet to vary fuel-air ratio and establish the proper setting for maximum K. I.

NOTE A2.5—A spill carburetor assembly is utilized by some online octane analyzer systems for application of Test Method D 2885.

A2.4.7 *Fuel Flow Control Jet*—An orifice having an internal diameter sized to restrict fuel flow to the vertical jet of the carburetor for use with fuel delivery systems that are dependent on establishing a fuel level in the vertical jet that is within a specified dimension referenced to the centerline of the carburetor venturi.

A2.4.7.1 *Horizontal Jet*, specify hole size for method and operating conditions (75988).

A2.4.7.2 *Carburetor Adjustable Horizontal Jet Assembly*—Alternative equipment for a hole-size jet (75988). Install a tapered needle, screw adjustable, with or without a graduated scale, so that the needle enters a standard horizontal jet (75988), which is drilled to approximately a 0.050-in. diameter. Adjustment of the needle permits changing the flow characteristics of fuel delivered to the vertical jet of the carburetor. A change in needle setting effectively changes the fuel level at which the fuel-air ratio for maximum K.I. occurs for a specific fuel.

A2.4.8 *Belting, Engine Flywheel to Power Absorption Motor*, set of two “C” section, V-belts approximately 2160-mm or 85-in. length (B5500). (**Warning**—The cross-sectional dimensions of the V-belts are critical for the knock testing unit to operate at the specified rotational speed.)

A2.4.9 *Electrical Switchgear*, includes input connections and circuit protection for three phase power to operate the power absorption motor, and single phase power to operate start-stop circuitry, controls, heaters, safety devices, and instrumentation. Circuit design shall ensure that failure of either the single phase or three phase power source will disconnect the other source.

A3. INSTRUMENTATION DESCRIPTION AND SPECIFICATIONS

A3.1 Instrumentation

A3.1.1 The single cylinder test engine unit for the determination of O.N. is manufactured by Waukesha Engine Division, Dresser Industries, Inc. and includes both critical and non-critical instrumentation. Waukesha Engine Division Reference Numbers are included in parentheses after all critical items and

where appropriate for non-critical items although these latter listings do not imply they are mandatory.

NOTE A3.1—The Waukesha Engine Division Reference Numbers are for the purpose of specifying components as applicable to this test method. These numbers are not to be used for purchasing parts from the supplier.

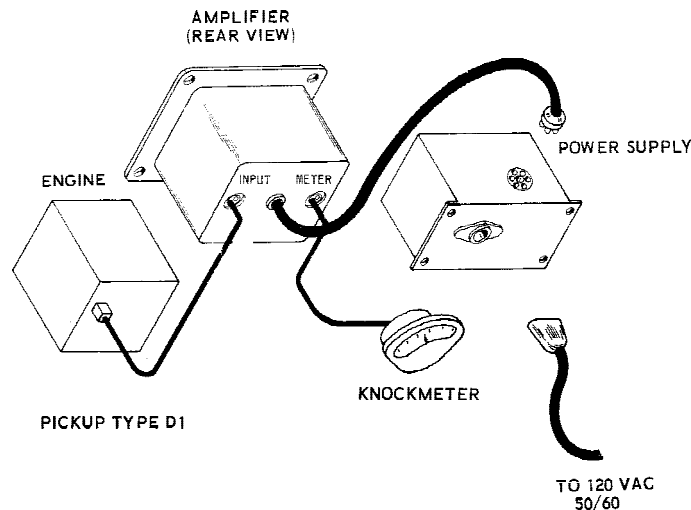

FIG. A3.1 Components of Knock Measurement Instrumentation

Users must always refer to the part numbers listed in the current Waukesha Engine Division CFR Parts Catalog when ordering components.

A3.2 Critical Instrumentation

A3.2.1 Critical instrumentation components or specifications, or both, that shall be used for these test methods are listed.

A3.2.2 *Knock Measurement System*—Determination of the O.N. of spark-ignition engine fuels requires measurement of the intensity of knock that is produced in the test engine combustion chamber. The multicomponent knock measurement system instrumentation (see Fig. A3.1) includes a detonation pickup (sensor), a detonation meter to condition the knock signal, and a knockmeter to display the K.I. signal. All of these components are critical because of their empirical design criteria established to make them simulate the knock measuring characteristics of the bouncing pin system which was the original instrumentation.

A3.2.3 *Detonation Pickup*—Model D1 (109927) having a pressure sensitive diaphragm, magnetostrictive core rod, and coil incorporated in a hollow steel housing to generate a voltage proportional to rate-of-change of pressure within the combustion chamber. The specifications are as follows:

A3.2.3.1 Single pin output electrical connector having an $1\frac{1}{16}$ –24 male thread.

A3.2.3.2 $\frac{7}{8}$ –18 male threaded housing for installation in the cylinder.

A3.2.3.3 Overall length of $2\frac{3}{16}$ in.

A3.2.3.4 Maximum housing diameter of $1\frac{1}{16}$ in.

A3.2.3.5 *Electrical Resistance Cold*, approximately 480 Ω when measured between the center connector pin and the housing at room temperature.

A3.2.3.6 *Electrical Resistance Hot*, approximately 650 Ω when measured between the center connector pin and the housing at engine operating temperature.

A3.2.3.7 *Output Voltage*—New pickups are quality control tested to produce at least a 1.8 V positive pulse from zero to peak of the detonation signal spike. This measurement is made with the pickup operating in a Motor method engine on a volumetric blend of 74 % toluene, 15 % isooctane, and 11 %

n-heptane at standard conditions with the pickup center connector pin only connected to a calibrated cathode ray oscilloscope.

NOTE A3.2—Pickup output voltage normally increases with age as exposure to detonation pressures causes the thin diaphragm to conform more closely to the curved anvil of the internal core rod assembly. Such voltage changes are not known to adversely affect K.I. measurements or octane ratings.

A3.2.4 *Detonation Meter*—(Model 501-C) The specifications are as follows:

A3.2.4.1 Input filter (low pass) that, for each combustion cycle, develops a characteristic pulse that depicts the rate-of-change of pressure as normal combustion takes place along with the sharp pulse resulting from knock. Selection of the critical frequency range provides the means by which the electronic metering system duplicates the measurement process based on the original bouncing pin performance that created the O.N. scale. The required signal frequency response characteristic is as follows:

Input Frequency, Hz	Output Frequency Response, dB
dc to 2000	-0.5 \pm 1.0
2250	-3.0 \pm 0.2
2500	-6.5 \pm 0.3
5000	<-40
6500 \pm 100	Point where dB drop maximizes and reverses (point of minimum output)

A3.2.4.2 Amplifier and associated regulated power supply circuitry to condition the filtered frequency signal and develop a steady output that is proportional to the average portion of the rate-of-change of pressure characteristic that is due to knock. This requires subtracting the part of the signal that results from normal combustion, integrating the resulting knock pulses and converting the half-wave ac characteristic to a dc output potential for display. Inherent in the measurement process is the requirement for adjustment of several variables; signal bias (zero) calibration, selection of the degree of integration for acceptable signal-to-noise ratio (time constant), selection of the sensitivity to changes in knock level (spread), and adjustment of the signal amplification (meter reading) so that the signal can be scaled for display.

A3.2.4.3 *Qualification*—Whenever a detonation meter component is replaced or the meter is suspected of malfunction, test the detonation meter in accordance with the Model 501-C Detonation Meter Performance Qualification Procedure²⁵ that specifies two checks of the electrical functions.

(1) The input filter frequency response characteristic.

(2) The peak detection efficiency check that tests the circuitry to ensure that the knock signals are faithfully transmitted throughout the signal conditioning steps to produce the proper output signal.

A3.2.5 *Signal Cables:*

Cable	Description	Reference No.
Input Cable	Detonation pickup to amplifier	210109
Output Cable	Amplifier to display instrument	111279

A3.2.6 *Knockmeter (109980)*, having the following specifications:

A3.2.6.1 *Type*—Electrical analogue indicating instrument operating on the d’Arsonval principle.

A3.2.6.2 *Suspension*—Pivot and jewel or taut-band.

A3.2.6.3 *Scale*—Length equal to or greater than 5.0 in. (127 mm) with angular needle deflection of 250°.

A3.2.6.4 *Scale Divisions*—One hundred equal valued divisions, ten major, two intermediate, and five minor.

A3.2.6.5 *Operating Position*—Vertical $\pm 20^\circ$.

A3.2.6.6 *Readability*—0.5 division by a person of normal vision viewing from a distance of 3 ft (1 m).

A3.2.6.7 *Case*—Sealed to prevent entrance of dust and vapors.

A3.2.6.8 *Range*—Incorporate the proper shunt resistance for the knockmeter by selection and measurement of current range and meter resistance as follows:

(1) *Knockmeter Current*, $1.0 \text{ mA} \leq I_M \leq 3.0 \text{ mA}$,

(2) *Knockmeter Resistance*, $R_M \leq (0.0325/I_M) - 9.901 \ \Omega$,

(3) *Measurement of Knockmeter Resistance*—Simultaneously measure the full scale current through the knockmeter, I_M , and the voltage drop across the knockmeter, V_M . Compute $R_M = V_M/I_M$.

(4) Compute the correct shunt resistance to be used with the knockmeter:

$$R_S = \frac{1000 R_M I_M}{3.28 - I_M (1000 + R_M)} \quad (\text{A3.1})$$

(5) Connect this value of R_S securely and permanently across the knockmeter terminals.

NOTE A3.3—A knockmeter with a selected shunt resistance connected directly across it can only be utilized with a detonation meter (model 501 types) amplifier circuit that includes an output resistance, R-260 of 1000 Ω but does not include an internal shunt resistor, R-261 = 10 Ω .

A3.2.6.9 *Precision and Damping Check*—The knockmeter with applied shunt resistance shall comply with the requirements of the following test procedure:

(1) Adjust the knockmeter pointer to zero.

(2) Connect the knockmeter (shunted) to a variable voltage source in series with a resistor of $1000 \ \Omega \pm 1 \%$.

(3) *Range Check*—Apply an exciting voltage (V_e) to produce a full scale knockmeter reading of exactly 100 (with tapping). Record the voltage across the knockmeter as V_{fs} .

$$\text{Required: } V_{fs} = 3.28 \text{ V} \pm 5 \% \quad (\text{A3.2})$$

(4) *Knockmeter Tracking Error (TE) Check*—Apply an exciting voltage (V_e) to sequentially produce knockmeter readings (M) of 20, 30, 40, 50, 60, 70, and 80 divisions on the knockmeter scale. Record M and V_e , at each point.

$$\text{Compute } TE = M - (V_e/V_{fs}) \times 100 \text{ for each point} \quad (\text{A3.3})$$

$$\text{Required: Maximum } TE = \pm 1 \%$$

(5) *Repeatability Check*—Without tapping or overshoot, apply an exciting voltage to produce exactly a mid-scale (50) knockmeter reading. Record the voltage across the knockmeter as V_A . Increase the exciting voltage until full-scale deflection or a knockmeter reading of 100 is obtained, then reduce the exciting voltage until, without overshoot or tapping, the knockmeter is again at mid-scale (50). Record the voltage across the knockmeter as V_B .

$$\text{Compute repeatability} = [(V_A - V_B)/V_{fs}] \times 100 \quad (\text{A3.4})$$

$$\text{Required: Maximum repeatability} = \pm 0.5 \%$$

(6) *Damping Check*—By trial and error, determine that value of exciting voltage that, when suddenly applied, will cause the knockmeter to swing to exactly full scale ($M = 100$). When the needle comes to rest, record this voltage as M_r .

$$\text{Compute percent overshoot} = [(100 - M_r)/M_r] \times 100 \quad (\text{A3.5})$$

$$\text{Required: Overshoot of less than } 25 \%$$

A3.2.6.10 The knockmeter shall meet or exceed any other performance requirements of Standard C-39.1 for millimetres of accuracy class 1.0.

A3.2.7 *System Tracking Accuracy Check*—The knockmeter connected to the detonation meter shall respond accurately and linearly to specific input signals based on measurements determined using the following procedure:

A3.2.7.1 *Test Equipment Required:*

(1) Stable dc signal source, such as Size D alkaline battery (1.5 V).

(2) Battery Holder.

(3) Amphenol No. 80, MC2M cable plug for connecting the signal source to the detonation meter input connector.

(4) Detonation Meter.

(5) Single Conductor, insulated, electrical wire.

(6) Knockmeter.

(7) Assemble test equipment components in accordance with Fig. A3.2.

A3.2.7.2 *Check Procedure*—Perform the following steps with the engine stopped to minimize electrical interference:

(1) Turn off the detonation meter POWER switch and record METER READING and SPREAD control dial settings to facilitate return to normal operating conditions at the completion of this check procedure.

(2) Zero the knockmeter needle mechanically, using the adjusting screw provided on the knockmeter face.

(3) Disconnect the pickup cable from the detonation meter input socket and connect the dc signal source to this socket.

(4) Turn on the detonation meter POWER switch.

²⁵ Supporting data have been filed at ASTM International Headquarters and may be obtained by requesting Research Report RR: D02-1326.

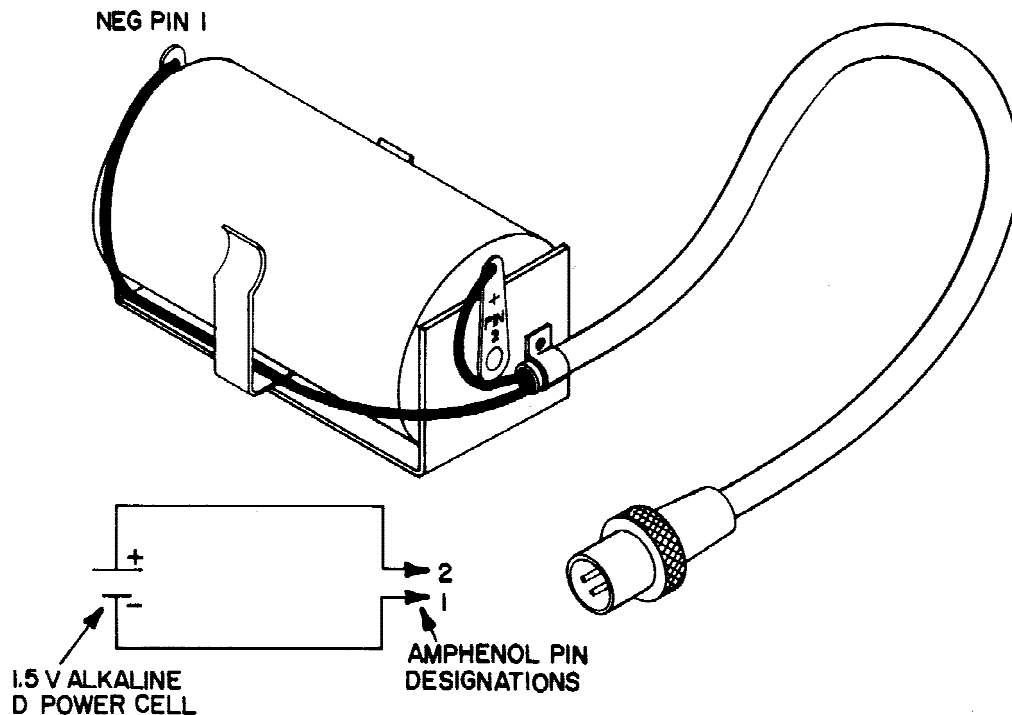

FIG. A3.2 Test Signal Source—Knockmeter Tracking Accuracy Check

(5) Set the detonation meter METER switch to OPERATE, the coarse SPREAD (outer step dial) control to 5, the fine SPREAD (inner dial) fully counterclockwise to 0, and the TIME CONSTANT selector to 1.

(6) Adjust METER READING coarse and fine controls to achieve a mid-scale knockmeter reading and allow the system to reach equilibrium.

(7) Establish a knockmeter reading of 80 by first setting the SPREAD coarse control to 8 and then adjusting the METER READING dial to obtain exactly 80 knockmeter divisions. (**Warning**—Allow 10 s for equilibrium after any change and tap the knockmeter near its pivot point before each reading in this and succeeding steps.)

(8) Establish a knockmeter reading of 20 by first setting the SPREAD coarse control to 2 and then adjusting the ZERO screw to obtain exactly 20 knockmeter divisions.

NOTE A3.4—The ZERO screw is accessible by removing the restrained cap cover.

(9) Repeat the last two interacting steps to establish precisely 80 and 20 knockmeter readings when the SPREAD coarse control is set to 8 and 2 respectively.

(10) Record the knockmeter reading for each SPREAD coarse control setting from 2 through 8.

NOTE A3.5—A perfectly linear knockmeter system should produce knockmeter readings that are exactly ten times the SPREAD coarse control setting. *Example*—A SPREAD coarse control setting of 5 should result in a knockmeter reading of 50.

(11) If the knockmeter reading for any SPREAD coarse control setting deviates by more than two divisions from linearity, the tracking accuracy is inadequate and appropriate repairs are required.

NOTE A3.6—Non-linearity is typically caused by a defective knockmeter.

(12) When the tracking accuracy check is completed, restore the instrument connections and reset the detonation meter SPREAD and METER READING dials for normal operation.

A3.2.8 Temperature Measurement:

A3.2.8.1 Intake Mixture Thermometer Assembly (110351-ASM), using a thermometer having a range from 95 to 175°C graduated in 1°C divisions (200°F–350°F graduated in 2°F divisions) and conforming to the requirements for Thermometer 86C (86F) in Specification E 1.

NOTE A3.7—The thermometer or other components of the Intake Mixture Thermometer Assembly are not available as separate items.

A3.2.9 Pressure Measurement:

A3.2.9.1 Compression Pressure Gage Assembly (110304-ASM) including a 0 to 300 psi Pressure Gage (105028), Deflator Assembly (110305), Flexible Hose Assembly (110641), Barrel (75777), Check Valve Assembly (105033), Screen Plug Assembly (75988-ASM), and Check Valve Washer (75941). The complete assembly shall be regularly calibrated using suitable pneumatic dead weight testing equipment.

A3.2.10 Cylinder Height Measurement:

A3.2.10.1 Compression Ratio (Digital) Counter Assembly (110514-ASM), including Compression Ratio Counter

(110514), Flexible Shaft (110513), and associated hardware for connection of the flexible shaft to the engine cylinder clamping sleeve and worm screw.

(1) The digital counter assembly is required for knock testing units that are used for octane ratings determined using the C.R. procedure. It may also be utilized for knock testing units used for octane ratings determined by the bracketing procedures.

(2) One digital counter unit is equivalent to one tenth revolution of the worm screw and represents 0.0007 in. of cylinder height movement.

A3.2.10.2 Dial Indicator Assembly (110279-ASM), including Dial Indicator (110279), Indicator Bracket (110631), Adjusting Screw (111243), Adjusting Screw Bracket (110349), and associated hardware for connection of the dial indicator and bracket to the engine clamping sleeve and the adjusting screw and bracket to the engine cylinder assembly.

(1) The dial indicator assembly is only applicable for knock testing units that are used for octane rating determined by the bracketing procedures.

(2) The dial indicator assembly provides a direct measure of cylinder height movement and is readable to 0.001 in. Although it is not required when a compression ratio digital counter assembly is utilized, it may be used, on units so equipped, as a secondary or backup reference of cylinder height.

A3.3 Equivalent Instrumentation

A3.3.1 *Detonation Meter*—Model 501-T—This instrument is no longer manufactured.

A3.3.1.1 *Input Filter*, (low pass) having the same signal frequency response characteristic specified for the Model 501-C detonation meter.

A3.3.1.2 *Amplifier*, and associated regulated power supply circuitry to condition the filtered frequency signal and develop a steady output that is proportional to the average portion of the rate-of-change of pressure characteristic that is due to knock.

NOTE A3.8—The Model 501-T Detonation Meter can be checked using the procedures that are given in RR:D02-1326.²⁵ However, application of these procedures may not be very useful.

A3.3.2 *Strip-Chart Recorder*, for K.I. indication, can be connected to the detonation meter output in parallel with the knockmeter. Select a recorder meeting the following specification:

A3.3.2.1 *Input Signal Range*—10.0 mV full-scale.

A3.3.2.2 *Input Impedance*—Greater than 1 meg ohm.

A3.3.2.3 *Scale*—Length equal to or greater than 5.0 in. (127 mm).

A3.3.2.4 *Scale Divisions*—One hundred equal valued divisions, ten major, two intermediate, and five minor.

A3.3.2.5 *Chart Speed*—127 to 254 mm/h (5 to 10 in./h) is adequate. The user may specify another chart speed range if desired.

A3.3.2.6 The recorder shall have an ungrounded differential input for parallel operation with a knockmeter, both terminals of which are approximately 50 V dc above ground.

A3.3.2.7 Recorder zero and span adjustment features are desirable. A recorder and knockmeter connected in parallel may not read the same value of K.I. Recorder zero and span adjustment is permissible to cause the instruments to agree over the range from 20 to 80 divisions. If these adjustment features are not available on a specific instrument, connect a 1000 ohm, 1 W precision multi-turn potentiometer across the recorder input signal terminals and adjust it to cause the instruments to read the same.

A3.4 Non-Critical Instrumentation

A3.4.1 *Temperature Measurement:*

A3.4.1.1 *Intake Air Thermometer Assembly* (106317-ASM), using a thermometer having a range from 15 to 70°C graduated in 1°C divisions (60 to 160°F graduated in 1°F divisions) and conforming to the requirements for Thermometer 83C (83F) in Specification E 1.

NOTE A3.9—The thermometer or other components of the Intake Air Thermometer Assembly are not available as separate items.

A3.4.1.2 *Temperature Controller* (111412), with associated thermal sensor, for on/off or proportional temperature control to within the specified limits as measured by the Intake Mixture Thermometer.

A3.4.1.3 *Cylinder Jacket Coolant Thermometer Assembly* (105180-ASM), using a thermometer having a range from –15 to 105°C graduated in 1°C divisions (0 to 220°F graduated in 2°F divisions) and conforming to the requirements for Thermometer 82C (82F) in Specification E 1.

NOTE A3.10—The thermometer or other components of the Cylinder Jacket Coolant Thermometer Assembly are not available as separate items.

A3.4.1.4 *Engine Crankcase Lubricating Oil Temperature Indicator* (105321), having a range from 15 to 85°C readable to 3°C (60 to 180°F readable to 5°F).

A3.4.2 *Pressure Measurement:*

A3.4.2.1 *Crankcase Internal Pressure Gage*, (pressure/vacuum gage) (109929) with a range that includes –500 to 500 mm (–20 to 20 in.) of water. A water manometer may be substituted.

A3.4.2.2 *Exhaust Back Pressure Gage*, with a range that includes 0 to 500 mm (0 to 20 in.) of water. A water manometer is a satisfactory alternative.

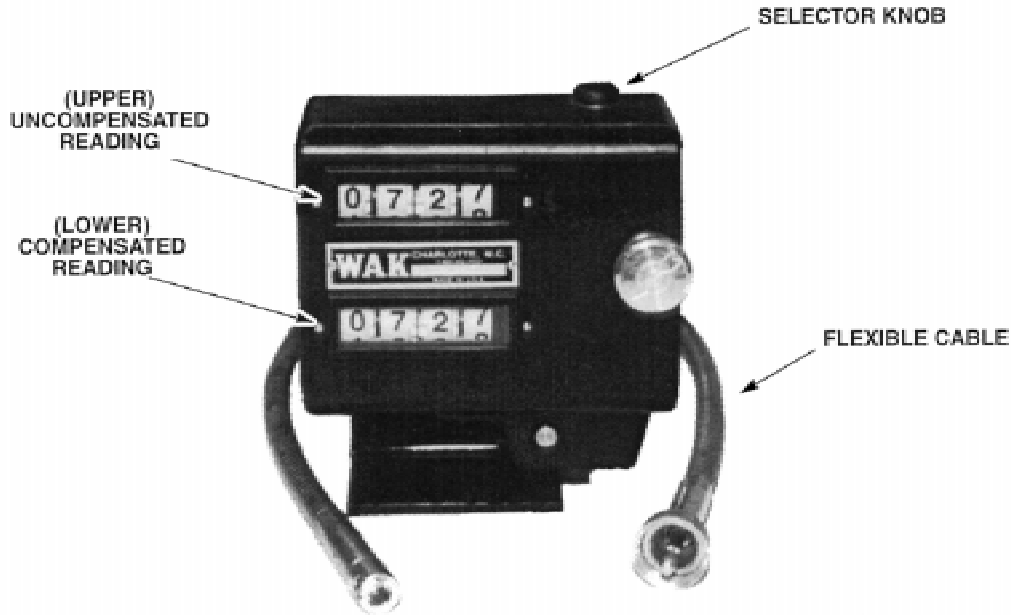

FIG. A4.2 C.R. Digital Counter

A4.1.3.1 With the dial indicator still positioned over the intake valve lifter, continue rotation of the flywheel until a maximum reading is obtained on the dial indicator.

A4.1.3.2 Read the dial indicator and compare it to the specification which is 0.246 to 0.250 in. If the rise is less than 0.243 in. from the base circle of the cam, wear of the lobe occurred and camshaft replacement is indicated.

A4.1.3.3 Valve lift for the exhaust cam lobe should also be checked by repeating the procedure with the dial indicator positioned over that valve lifter. The lift specification is the same as for the intake valve lifter.

A4.2 Basic Cylinder Height Indexing:

A4.2.1 *Measurement Principles*—C.R. is a significant variable in relation to knock in internal combustion engines and is a basic parameter for the knock testing methods. The CFR engine cylinder and clamping mechanism provide a means to change C.R. by moving the cylinder up or down with respect to the crankcase. As a convenient alternative to determination of the actual C.R., the vertical position of the cylinder can be measured and provides an indication that is proportional to C.R. Two approaches to indicating the cylinder height are applicable as follows:

A4.2.1.1 *Compression Ratio Digital Counter Assembly*—See Fig. A4.2. A flexible cable connects the cylinder clamping sleeve worm shaft to a mechanical digital counter unit that has two digital display counters or indicators. The input shaft of the unit is directly connected to the upper digital indicator and the digital counter reading responds to any rotation of the worm shaft which moves the engine cylinder up or down. The lower digital indicator is directly connected to the input shaft of the unit when a selector knob is positioned to 1 but is disengaged when the selector knob is at any other position. The disengagement feature is utilized to offset the lower indicator from the

upper indicator so that the differential digital counter reading can be compensated for other than standard barometric pressure conditions. The reading on the lower digital counter thus provides compensated values for knock test units operated at other than standard 29.92 in. Hg (101.0 kPa) barometric pressure conditions. Digital counter reading changes in direct proportion to C.R. and a digital counter reading change of one digit is equal to 0.0007 in. movement of the cylinder height.

A4.2.1.2 *Dial Indicator Assembly*—See Fig. A4.3. The dial indicator is fastened to the cylinder clamping sleeve by a bracket. An adjusting screw with a flat circular anvil that contacts the spindle of the dial indicator is supported in a second bracket which is fastened to the engine cylinder. The adjusting screw provides the means to set the dial indicator to the proper reading when the device is being indexed and is then locked in place by a lock nut tightened against the bracket. Dial indicator readings change in inverse proportion with respect to C.R.; increasing in value when the cylinder is raised in the clamping sleeve. Cylinder height movement is indicated to the nearest 0.001 in. There is currently no commercial offset mechanism to provide directly compensated dial indicator readings for knock test units operated at other than standard 29.92 in. Hg (101.0 kPa) barometric pressure conditions.

A4.2.2 *Establishing Basic Cylinder Height*—The cylinder height measurement instruments must be indexed to a standardized value after every top overhaul or equipment change that affects the combustion chamber. Originally, the clearance volume of the combustion chamber was set by introducing a specified volume of water to fill the clearance volume to the top of the pickup hole and then setting the indicator to a specific value. Experience has demonstrated that cylinder height indexing can be achieved by adjusting the cylinder position until a specified compression pressure is produced dependent on the

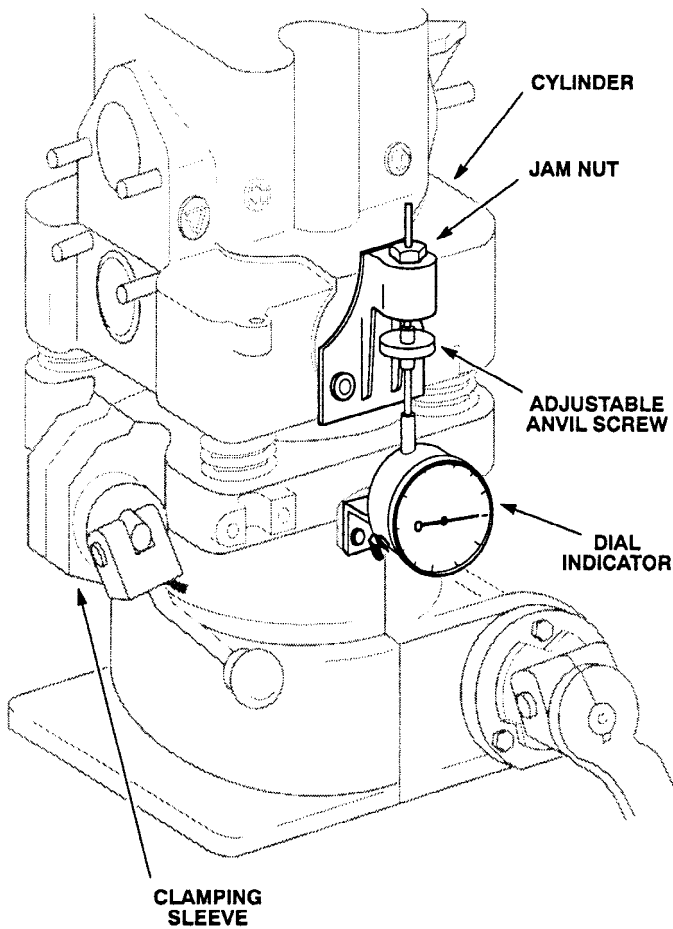

FIG. A4.3 Cylinder Height Dial Indicator

prevailing barometric pressure. Fig. 2, indicates the compression pressure that must be produced at standard operating conditions with the CFR engine motoring. The cylinder height instrument is then set to the basic value. For C.R. digital counter assemblies, the basic digital counter reading is 930. For dial indicator assemblies, the basic reading is 0.352 in.

A4.2.3 Basic Cylinder Height Indexing Procedure:

A4.2.3.1 Operate the knock test unit for sufficient time to reach temperature equilibrium, on a typical sample fuel, at standard operating conditions with an intake MIXT regulated to $149 \pm 1^\circ\text{C}$ ($300 \pm 2^\circ\text{F}$). (**Warning**—In addition to other precautions, users of the C.R. digital counter assembly are urged to set the upper and lower digital counters so that they both display the same value to ensure that indexing will be based on an uncompensated reading.)

A4.2.3.2 Cylinder height indexing requires the determination of compression pressure using the compression pressure gage assembly specified as critical instrumentation. The gage assembly shall have been calibrated in accordance with the instructions provided by the manufacturer. See Fig. A4.4.

A4.2.3.3 The following steps shall be performed as quickly as possible to ensure that the pressure readings represent hot engine conditions.

(1) Collect and have ready a calibrated compression pressure gage assembly and the tools required to remove the

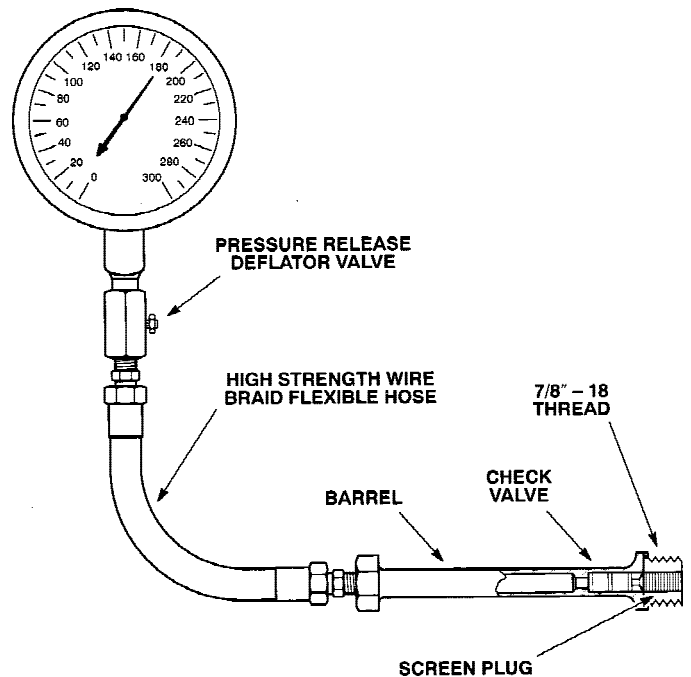

FIG. A4.4 Compression Pressure Gage Assembly

detonation pickup and install the gage assembly in the combustion chamber pickup hole.

(2) Users of the C.R. digital counter assembly shall disconnect the flexible cable by loosening the set-screw and slipping the cable connector off the digital counter unit and manually set the upper and lower digital counter readings so that both read 930.

(3) Determine the prevailing barometric pressure and using Fig. 2, read the compression pressure expected for cylinder height instrument indexing.

(4) Shut the engine down by turning the fuel off, turning the ignition switch off, and then positioning the engine power switch to off.

(5) Drain all fuel from the carburetor.

(6) Remove the detonation pickup cable connector, unscrew the detonation pickup from the cylinder, and install the compression pressure gage assembly. (**Warning**—Avoid contact with the detonation pickup because it is extremely hot and can cause serious burns.)

(7) Check that the ignition switch is off and that all fuel has been drained from the carburetor.

(8) Restart the engine and operate in a motoring mode only.

(9) Observe the compression pressure gage reading and adjust the cylinder height so that the expected compression pressure is indicated. Release the pressure once or twice using the deflator valve and make any required change in cylinder height so that the expected compression pressure is obtained. (**Warning**—In addition to other precautions, read the compression pressure gage in whatever position it faces without twisting the gage and hose, which can distort the readings.)

(10) Users of the C.R. digital counter assembly must reconnect the flexible cable to the unit and tighten the set-screw while being careful not to change the digital counter readings from 930.

TABLE A4.1 Torque Specification Values

Item	Torque, lbf-ft	Torque, N-m
Cylinder clamping sleeve:		
Long stud nuts	42	57
Short stud nuts	83	113
Cylinder clamping cam bolt nut ^A	10	14
Cylinder clamping bolt nut ^B	5	7
Crankshaft balancing weight bolts	100	136
Balancing shaft weight bolts	100	136
Balancing shaft weight bolt locknuts	75	102
Balancing rod bolts (high speed crankcase)	100	136
Connecting rod bolts	104	141
Flywheel nut	200	271
Spark plug	25 to 30	34 to 41
Detonation pick-up, type D-1	30	41

^A With clamp handle in locked position. (**Warning**—Do not exceed 25 lbf-ft to avoid cylinder distortion.)

^B When motorized C.R. changer is used.

(11) Users of the dial indicator assembly must loosen the lock nut, set the adjusting screw so that the dial indicator reading is 0.352 in., and then tighten the lock nut. Several respects of the adjustment may be required to obtain the 0.352 in. reading when the lock nut is retightened.

(12) Shut the engine down, remove the compression pressure gage assembly, install the detonation pickup with a new gasket, and tighten the pickup to the torque setting specified in Table A4.1.

A4.3 Checking Compression Pressures—Checking compression pressure with the engine operating at each of two different C.R. conditions can be a useful indication of combustion chamber and valve condition. The C.R. values selected for making the motor method checks are those for 81.1 and 105 O.N. levels.

A4.3.1 Operate the knock test unit for sufficient time to reach temperature equilibrium, on a typical sample fuel having an O.N. in the mid-80 O.N. range, at standard operating conditions and with the intake MIXT regulated to $149 \pm 1^\circ\text{C}$ ($300 \pm 2^\circ\text{F}$).

A4.3.2 Collect and have ready a calibrated compression pressure gage assembly and the tools required to remove the detonation pickup and install the gage assembly in the combustion chamber pickup hole.

A4.3.3 Shut the engine down by turning the fuel off, turning the ignition switch off and then positioning the engine power switch to off.

A4.3.4 Drain all fuel from the carburetor.

A4.3.5 Remove the detonation pickup cable connector, unscrew the detonation pickup from the cylinder, and install the compression pressure gage assembly. (**Warning**—Avoid contact with the detonation pickup because it is extremely hot and can cause serious burns.)

A4.3.6 Check that the ignition switch is off and that all fuel has been drained from the carburetor.

A4.3.7 Restart the engine and operate in a motoring mode only.

A4.3.8 Determine the compression pressures at the cylinder height settings for the two O.N. levels in accordance with Table A4.2.

TABLE A4.2 Specifications for Checking Compression Pressures

Octane number	81.1	105
Compensated digital counter setting		
For $\frac{3}{16}$ venturi	578	1008
For $\frac{19}{32}$ venturi	515	965
For $\frac{3}{4}$ venturi	461	912
Compensated dial indicator setting, in.		
For $\frac{3}{16}$ venturi	0.602	0.297
For $\frac{19}{32}$ venturi	0.647	0.328
For $\frac{3}{4}$ venturi	0.685	0.365
Compression pressure, psi	120 ± 2	194 ± 4

A4.3.8.1 Use cylinder height settings compensated for barometric pressure in accordance with the compensation tables in Annex A6.

A4.3.8.2 Observe the compression pressure and record the readings.

A4.3.8.3 If the compression pressures are not within the limits, repeat the basic cylinder indexing procedure, and if necessary, perform the maintenance required to obtain the proper compression characteristic.

A4.4 Setting Standard Knock Intensity—O.N. ratings, regardless of octane level or barometric pressure, are presumed to be determined at approximately the same degree of knock, which is termed standard K.I. Every engine follows a natural track or characteristic of cylinder height variation with changes in O.N. that is based on the assumed standard K.I. The average of the values determined for numerous engines defines the guide table of standard K.I. for this method. The basic setting, established when the detonation meter was first accepted, duplicated the cylinder height at 85 O.N., which had been used for the original bouncing pin. “Setting the engine on the guide table,” a term that has been used historically, denotes operating the engine on a PRF blend of known O.N., under standard conditions, with the cylinder height set to the value specified by the appropriate guide table. If the fuel-air ratio is then adjusted to the maximum knock condition, the engine will be operating at standard K.I. Adjustment of the detonation meter to cause the knockmeter to read 50 ± 2 divisions, establishes the required numerical display of this standardized knock condition.

A4.4.1 The procedure for setting standard K.I. at any selected O.N. level is as follows:

A4.4.1.1 Prepare a PRF blend for the O.N. selected and introduce it to a fuel tank and position the fuel selector-valve to operate the engine on this fuel.

A4.4.1.2 Using the appropriate guide table from Annex A6, and the proper compensation for other than standard barometric pressure (compensation tables in Annex A6), determine the cylinder height (digital counter or dial indicator reading), and adjust the cylinder height to this value.

A4.4.1.3 Determine the fuel-air ratio for maximum K.I.

A4.4.1.4 Adjust the detonation meter METER READING dials so that the knockmeter reading averages 50 ± 2 divisions.

A4.5 Setting Overall Knock Measurement System Parameters:

A4.5.1 Principles of Knock Measurement—The knock measurement system incorporates the detonation pickup, detonation meter, and the indicating knockmeter as illustrated in Fig.

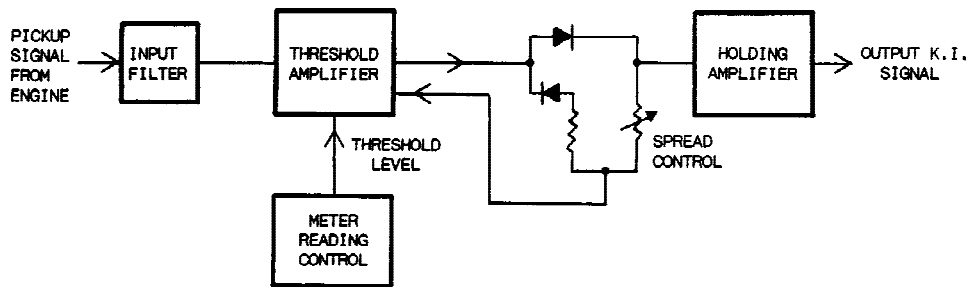

FIG. A4.5 Block Diagram of Knock Measurement System

A4.5. The rate-of-change of combustion chamber pressure signal produced by the detonation pickup is modulated by the detonation meter input filter circuit to create a signal which will simulate the octane rating characteristics of the original bouncing pin instrumentation. Further conditioning of this signal by the detonation meter circuitry subtracts away the portion that represents normal or knock-free operation, amplifies and stretches the remaining knock pulse, integrates multiple cycles of the knock pulse to average the engine characteristic, and finally produces a dc output signal proportional to knock for display by the knockmeter.

A4.5.2 *Spread Characteristic*—Detonation meter spread or sensitivity (K.I. divisions per O.N.) is a function of the detonation meter SPREAD dial settings. Regardless of the spread dial setting, however, K.I. divisions per O.N. varies as O.N. level is changed because of the engine operating characteristics and the nature of the O.N. scale. The effect of spread variation with O.N. level for a selected spread dial setting is illustrated in Fig. A4.6. In the 95 to 100 O.N. range, the maximum amount of spread achievable can be greater than desired because K.I. reading may become too unstable for satisfactory observation (excessive signal-to-noise ratio). However, as the figure demonstrates, a workable spread setting can be selected to permit rating over a wide O.N. range. Use of a spread set to approximately 12 to 14 for the 90 O.N. level typically achieves this condition and reduces the frequency of making spread dial changes when testing sample fuels in the commercial fuel O.N. range. When testing samples at levels below 80 O.N., spread naturally decreases and spread dial changes are desirable to maximize sensitivity for optimum measurement resolution at these lower O.N. levels. Spread can also naturally decrease as O.N. is increased above 100. Resetting the spread dials becomes necessary, in this case, not only to gain measurement resolution but more importantly, to ensure that the electronic conditioning of the detonation meter circuitry removes the portion of the measured signal that represents normal combustion. At these high O.N. levels, it is important that the retained signal represent the knock function and not a “knockless knock” measurement.

A4.5.3 *Setting Spread*—Setting spread at any selected O.N. level involves adjustment of the detonation meter SPREAD and METER READING controls. Each control has independent coarse and fine adjustment dials as illustrated in Fig. A4.7. The control ratio of the coarse dial (10 point switch) to the fine dial is 10:1 for both SPREAD and METER READING controls. Change spread as follows:

A4.5.3.1 Operate the engine on the PRF blend for the selected O.N. level at standard operating conditions.

A4.5.3.2 To increase spread, increase the knockmeter reading to 80 or more by adjusting the fine spread dial clockwise and then reduce the knockmeter reading to 50 ± 3 by adjusting the fine meter reading dial counterclockwise.

A4.5.3.3 To decrease spread, decrease the knockmeter reading to 20 or less by adjusting the fine spread dial counterclockwise and then increase the knockmeter reading to 50 ± 3 by adjusting the fine meter reading dial clockwise.

A4.5.3.4 If at any point during the spread adjustment procedure, adequate range of adjustment is not possible using the fine controls, the coarse dial for that function should be moved so that proper range is available using the fine dial.

A4.5.4 *Measuring Spread*—Spread is measured using either a two PRF technique or a one PRF technique. In every case, adjust the PRF fuel-air ratio to produce maximum K.I.

A4.5.4.1 The two PRF technique measures the change in K.I. divisions that occurs when the engine, operating at the guide table C.R. or cylinder height for the O.N. of one PRF, is switched to the second PRF that is either 1.0 O.N. higher or lower than the first PRF.

A4.5.4.2 The single PRF technique measures the change in K.I. divisions that occurs when the engine is first operated at the guide table C.R. for the O.N. of the PRF and then at the C.R. equivalent to one O.N., either higher or lower than that of the PRF.

A4.6 *Adjusting Crankcase Lubricating Oil Pressure*—The oil pressure of the lubricating oil in the engine crankcase gallery is dependent on the setting of the pressure control valve located at the lower left side of the engine crankcase when viewed from in front of the engine. See Fig. A4.8.

A4.6.1 Adjust the oil pressure with the engine hot and running.

A4.6.2 Remove the acorn nut and gasket from the oil pressure control valve assembly.

A4.6.3 Loosen the gasketed locknut so that the adjusting screw is free.

A4.6.4 While observing the engine oil pressure gage, set the adjusting screw to obtain the specified 172 to 207 kPa (25 to 30 psi) pressure.

A4.6.5 Tighten the gasketed locknut while observing that the pressure remains within limits.

A4.6.6 Reinstall the gasket and acorn nut.

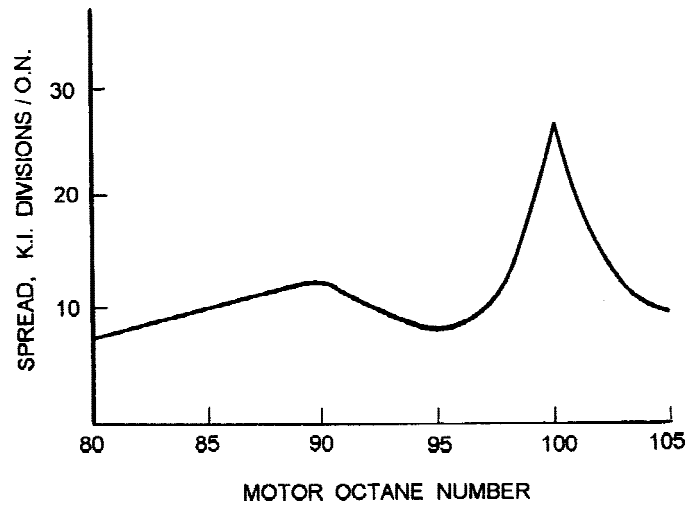

FIG. A4.6 Typical Detonation Meter Spread Characteristic

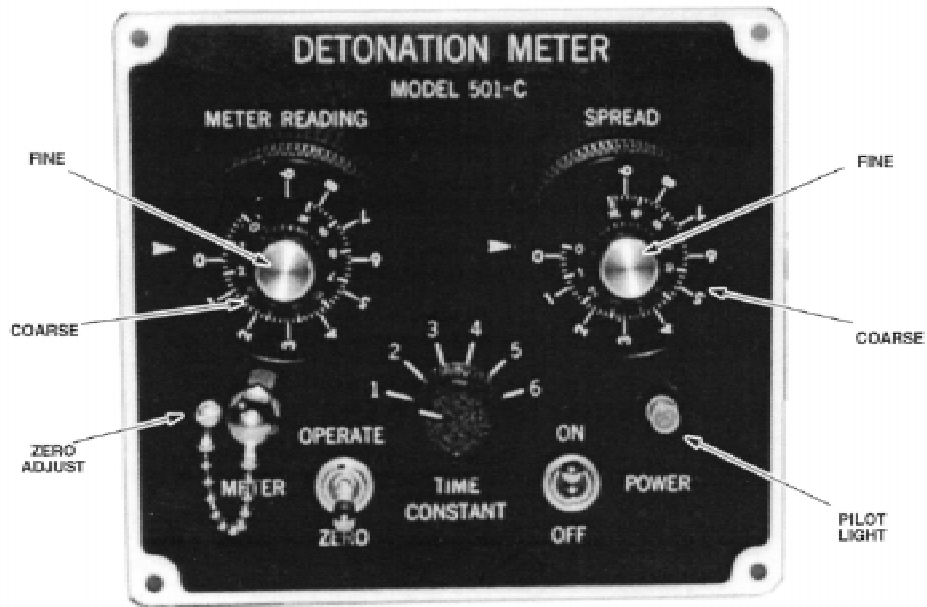

FIG. A4.7 Detonation Meter—Front Panel

A4.7 Engine Torque Tightening Specifications—See Table A4.1.

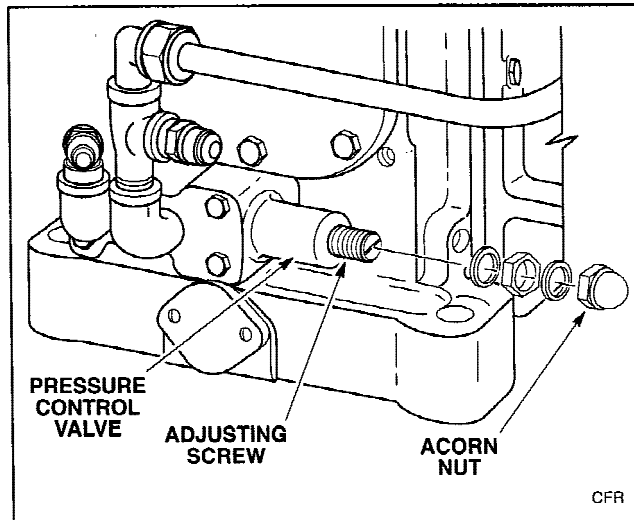

FIG. A4.8 Oil Pressure Control Valve Assembly

A5. REFERENCE FUEL BLENDING TABLES

A5.1 See Tables A5.1-A5.3.

TABLE A5.1 Octane Numbers for Blends of 80 Octane PRF and *n*-Heptane

Blends of 80 PRF and <i>n</i> -Heptane ⁴		
Octane Number	Percent 80 PRF	Percent <i>n</i> -Heptane
40.0	50	50
44.0	55	45
48.0	60	40
52.0	65	35
56.0	70	30
60.0	75	25
64.0	80	20
68.0	85	15
72.0	90	10
72.8	91	9
73.6	92	8
74.4	93	7
75.2	94	6
76.0	95	5
76.8	96	4
77.6	97	3
78.4	98	2
79.2	99	1
80.0	100	0

⁴ O.N. = 0.80 (% 80 PRF).

TABLE A5.2 Octane Numbers for Blends of 80 Octane PRF and Isooctane

Blends of 80 PRF and Isooctane ^A		
Octane Number	Percent 80 PRF	Percent Isooctane
80.0	100	0
81.0	95	5
82.0	90	10
83.0	85	15
84.0	80	20
85.0	75	25
86.0	70	30
87.0	65	35
88.0	60	40
89.0	55	45
90.0	50	50
91.0	45	55
92.0	40	60
93.0	35	65
94.0	30	70
95.0	25	75
96.0	20	80
97.0	15	85
98.0	10	90
99.0	5	95
100.0	0	100

^A O.N. = 0.80 (% 80 PRF) + 1.00 (% isooctane).

TABLE A5.3 Octane Numbers for Blends of Tetraethyllead in Isooctane^A

NOTE—Dilute tetraethyllead (mL TEL/gallon basis) is prepared so that when 2.0 mL of dilute fluid are added to a 400-mL batch of Isooctane, the resulting blend will contain 2.0 mL TEL per U.S. gallon.

mL TEL per U.S. Gallon	Octane Number ^A	mL TEL per U.S. Gallon	Octane Number
0.0	100.0	1.2	109.6
0.05	100.7	1.4	110.5
0.1	101.3	1.5	111.0
0.2	102.5	2.0	112.8
0.3	103.5	2.5	114.3
0.4	104.4	3.0	115.5
0.5	105.3	3.5	116.6
0.6	106.0	4.0	117.5
0.7	106.8	4.5	118.3
0.8	107.4	5.0	119.1
0.9	108.0	5.5	119.7
1.0	108.6	6.0	120.3

^A
$$O.N. = \frac{100 + 0.736(T) + [1.0 + 1.472(T) - 0.035216(T)^2]^{0.5}}{28.28(T)}$$

where: *T* = mL TEL per U.S. gallon in isooctane.

A6. GUIDE TABLES OF CONSTANT KNOCK INTENSITY

A6.1 See Tables A6.1-A6.10.

TABLE A6.1 Guide Table for Standard Knock Intensity at Standard Barometric Pressure^A— $\frac{9}{16}$ in. Venturi Digital Counter Readings for Motor Octane Numbers

NOTE—See Tables A6.9 and A6.10 for digital counter reading compensation for the applicable barometric pressure range between 104.7 kPa (31.0 in. Hg) and 94.6 kPa (28.0 in. Hg).

Motor Octane Number	0.0	0.1	0.2	0.3	0.4	0.5	0.6	0.7	0.8	0.9
	Digital Counter Readings									
40	171	171	172	172	173	174	175	175	176	176
41	176	177	178	178	179	179	180	180	181	182
42	182	183	184	185	185	186	186	187	188	188
43	189	189	190	190	191	192	192	193	194	195
44	195	196	196	197	197	198	199	199	200	201
45	202	202	203	203	204	204	205	206	207	207
46	208	209	209	210	211	212	212	213	213	214
47	214	215	216	217	218	219	219	220	220	221
48	221	222	223	224	225	226	226	227	227	228
49	228	229	230	231	232	233	233	234	234	235
50	235	236	237	238	239	240	241	242	243	243
51	244	244	245	245	246	247	248	249	250	250
52	251	252	252	253	254	255	256	257	257	258
53	259	259	260	261	262	263	264	265	265	266
54	266	267	268	269	270	271	272	273	274	274
55	275	275	276	277	278	279	280	281	282	282
56	283	283	284	285	286	287	288	289	290	291
57	292	292	293	294	295	296	297	298	299	299
58	300	301	302	303	304	305	306	306	307	307
59	308	309	310	311	312	313	314	315	316	316
60	317	318	319	320	321	322	323	324	325	326
61	327	328	329	329	330	331	332	333	334	335
62	336	337	337	338	339	340	341	342	343	344
63	345	346	347	348	349	350	351	352	353	354
64	355	356	357	357	358	359	360	361	362	363
65	364	365	366	367	368	369	370	371	372	373
66	374	375	376	377	378	379	380	381	382	383
67	384	385	386	388	389	390	391	392	393	394
68	395	396	397	398	399	400	401	402	403	405
69	406	407	408	409	410	412	413	414	415	416
70	417	419	420	421	422	423	424	426	427	428
71	429	430	431	433	434	436	437	438	439	440
72	441	443	444	445	446	447	448	450	451	453
73	454	455	457	458	460	461	462	463	464	465
74	467	468	470	471	472	474	475	477	478	479
75	481	482	484	485	486	488	489	491	492	494
76	495	496	498	499	501	502	503	505	506	508
77	509	510	512	513	515	517	519	520	522	524
78	526	527	529	531	533	534	536	537	539	540
79	542	544	546	548	550	551	553	554	556	558
80	560	562	564	565	567	568	570	571	573	575
81	577	578	580	582	584	585	587	589	591	592
82	594	596	598	599	601	603	605	606	608	610
83	612	613	615	617	619	620	622	623	625	627
84	629	631	633	635	637	639	641	643	644	646
85	648	650	652	654	656	658	660	662	664	666
86	668	670	672	674	675	677	679	681	683	685
87	688	690	692	694	695	698	699	702	704	706
88	708	709	712	714	716	718	721	722	725	726

TABLE A6.1 *Continued*

Motor Octane Number	0.0	0.1	0.2	0.3	0.4	0.5	0.6	0.7	0.8	0.9
	Digital Counter Readings									
89	728	730	732	735	736	739	740	743	745	746
90	749	750	753	754	757	759	761	763	764	767
91	769	771	773	776	777	780	781	783	785	787
92	790	791	794	795	798	800	801	804	805	808
93	809	812	814	816	818	819	822	824	826	828
94	831	832	835	836	838	840	842	845	846	849
95	850	852	855	856	859	860	863	864	866	869
96	870	873	874	876	879	880	881	884	886	888
97	890	891	894	895	897	900	901	904	905	907
98	910	911	912	915	917	918	921	922	924	926
99	928	929	931	934	935	936	939	941	942	945
100	948	949	950	952	953	955	956	957	959	960
101	960	962	963	965	966	967	969	970	972	973
102	974	976	977	979	980	980	981	983	984	986
103	987	988	988	990	991	991	993	993	994	994
104	995	997	998	1000	1001	1003	1004	1005	1006	1007
105	1008	1010	1011	1012	1014	1015	1016	1017	1018	1019
106	1020	1021	1022	1024	1025	1026	1027	1028	1029	1030
107	1031	1032	1033	1034	1035	1036	1037	1038	1039	1040
108	1041	1041	1042	1043	1044	1045	1046	1046	1047	1048
109	1049	1050	1051	1052	1053	1053	1054	1055	1056	1057
110	1058	1058	1059	1060	1061	1062	1063	1063	1064	1065
111	1066	1067	1068	1069	1069	1070	1071	1072	1073	1073
112	1074	1075	1076	1077	1078	1079	1080	1080	1081	1082
113	1083	1084	1084	1085	1086	1087	1088	1089	1090	1091
114	1092	1093	1093	1094	1095	1096	1097	1097	1098	1099
115	1100	1101	1101	1103	1103	1104	1105	1105	1107	1107
116	1108	1110	1110	1111	1111	1112	1114	1114	1115	1115
117	1117	1118	1118	1120	1120	1121	1122	1122	1124	1124
118	1125	1125	1127	1128	1128	1129	1129	1131	1131	1132
119	1132	1134	1134	1135	1136	1136	1138	1139	1141	1141
120	1142	1142	1144	1145

$$^A \text{Equivalent dial indicator reading} = 1.012 - \frac{\text{digital counter reading}}{1410}$$

TABLE A6.2 Guide Table for Standard Knock Intensity at Standard Barometric Pressure— $\frac{9}{16}$ in. Venturi Motor Octane Numbers for Digital Counter Readings

NOTE—See Tables A6.9 and A6.10 for digital counter reading compensation for the applicable barometric pressure range between 104.7 kPa (31.0 in. Hg) and 94.6 kPa (28.0 in. Hg).

Digital Counter Setting	0	1	2	3	4	5	6	7	8	9
	Motor Octane Number									
170	40.0	40.1	40.3	40.4	40.5	40.7	40.9	41.1	41.3	41.5
180	41.7	41.8	42.0	42.1	42.2	42.4	42.6	42.7	42.9	43.1
190	43.3	43.4	43.6	43.7	43.8	44.0	44.2	44.4	44.5	44.7
200	44.8	44.9	45.1	45.3	45.5	45.6	45.8	45.9	46.0	46.2
210	46.3	46.4	46.6	46.8	46.9	47.1	47.2	47.3	47.4	47.6
220	47.8	48.0	48.1	48.2	48.3	48.5	48.6	48.8	48.9	49.1
230	49.2	49.3	49.4	49.6	49.8	49.9	50.1	50.2	50.3	50.4
240	50.5	50.6	50.8	50.9	51.1	51.3	51.4	51.5	51.6	51.8
250	51.9	52.0	52.2	52.3	52.4	52.5	52.6	52.8	52.9	53.0
260	53.2	53.3	53.4	53.5	53.6	53.8	53.9	54.1	54.2	54.3
270	54.4	54.5	54.6	54.7	54.9	55.0	55.2	55.3	55.4	55.5
280	55.6	55.7	55.9	56.1	56.2	56.3	56.4	56.5	56.6	56.7
290	56.8	56.9	57.1	57.2	57.3	57.4	57.5	57.6	57.7	57.9
300	58.0	58.1	58.2	58.3	58.4	58.6	58.7	58.8	58.9	59.0

TABLE A6.2 *Continued*

Digital Counter Setting	0	1	2	3	4	5	6	7	8	9
	Motor Octane Number									
310	59.2	59.3	59.4	59.5	59.6	59.7	59.8	60.0	60.0	60.2
320	60.3	60.4	60.5	60.6	60.7	60.8	60.9	61.0	61.1	61.3
330	61.4	61.5	61.6	61.7	61.8	61.9	62.0	62.1	62.3	62.4
340	62.5	62.6	62.7	62.8	62.9	63.0	63.1	63.2	63.3	63.4
350	63.5	63.6	63.7	63.8	63.9	64.0	64.1	63.4	64.4	64.5
360	64.6	64.7	64.8	64.9	65.0	65.1	65.2	65.3	65.4	65.5
370	65.6	65.7	65.8	65.9	66.0	66.1	66.2	66.3	66.4	66.5
380	66.6	66.7	66.8	66.9	67.0	67.1	67.2	67.2	67.3	67.4
390	67.5	67.6	67.7	67.8	67.9	68.0	68.1	68.2	68.3	68.4
400	68.5	68.6	68.7	68.8	68.8	68.9	69.0	69.1	69.2	69.3
410	69.4	69.4	69.5	69.6	69.7	69.8	69.9	70.0	70.0	70.1
420	70.2	70.3	70.4	70.5	70.6	70.7	70.7	70.8	70.9	71.0
430	71.1	71.2	71.2	71.3	71.4	71.5	71.5	71.6	71.7	71.8
440	71.9	72.0	72.0	72.1	72.2	72.3	72.4	72.5	72.6	72.6
450	72.7	72.8	72.8	72.9	73.0	73.1	73.2	73.2	73.3	73.4
460	73.4	73.5	73.6	73.7	73.8	73.9	73.9	74.0	74.1	74.2
470	74.2	74.3	74.4	74.4	74.5	74.6	74.7	74.7	74.8	74.9
480	74.9	75.0	75.1	75.2	75.2	75.3	75.4	75.4	75.5	75.6
490	75.6	75.7	75.8	75.9	75.9	76.0	76.1	76.1	76.2	76.3
500	76.4	76.4	76.5	76.6	76.6	76.7	76.8	76.8	76.9	77.0
510	77.1	77.1	77.2	77.3	77.3	77.4	77.4	77.5	77.6	77.6
520	77.7	77.7	77.8	77.8	77.9	78.0	78.0	78.1	78.1	78.2
530	78.3	78.3	78.4	78.4	78.5	78.6	78.6	78.7	78.7	78.8
540	78.9	78.9	79.0	79.0	79.1	79.1	79.2	79.3	79.3	79.4
550	79.4	79.5	79.5	79.6	79.7	79.7	79.8	79.8	79.9	80.0
560	80.0	80.1	80.1	80.2	80.2	80.3	80.4	80.4	80.5	80.5
570	80.6	80.7	80.7	80.8	80.8	80.9	80.9	81.0	81.1	81.1
580	81.2	81.2	81.3	81.4	81.4	81.5	81.5	81.6	81.6	81.7
590	81.8	81.8	81.9	81.9	82.0	82.0	82.1	82.2	82.2	82.3
600	82.3	82.4	82.4	82.5	82.6	82.6	82.7	82.7	82.8	82.8
610	82.9	83.0	83.0	83.1	83.1	83.2	83.2	83.3	83.4	83.4
620	83.5	83.5	83.6	83.7	83.7	83.8	83.8	83.9	83.9	84.0
630	84.0	84.1	84.2	84.2	84.3	84.3	84.4	84.4	84.5	84.5
640	84.6	84.6	84.7	84.7	84.8	84.8	84.9	84.9	85.0	85.0
650	85.1	85.1	85.2	85.2	85.3	85.3	85.4	85.4	85.5	85.5
660	85.6	85.6	85.7	85.7	85.8	85.8	85.9	86.0	86.0	86.1
670	86.1	86.2	86.2	86.3	86.3	86.4	86.4	86.5	86.5	86.6
680	86.6	86.7	86.7	86.8	86.8	86.9	86.9	87.0	87.0	87.1
690	87.1	87.2	87.2	87.3	87.3	87.4	87.4	87.5	87.5	87.6
700	87.6	87.7	87.7	87.8	87.8	87.9	87.9	88.0	88.0	88.1
710	88.1	88.2	88.2	88.2	88.3	88.3	88.4	88.4	88.5	88.5
720	88.6	88.6	88.7	88.7	88.8	88.8	88.9	88.9	89.0	89.0
730	89.1	89.1	89.2	89.2	89.3	89.3	89.4	89.4	89.5	89.5
740	89.6	89.6	89.7	89.7	89.8	89.8	89.9	89.9	90.0	90.0
750	90.1	90.1	90.2	90.2	90.3	90.3	90.4	90.4	90.5	90.5
760	90.6	90.6	90.7	90.7	90.8	90.8	90.9	90.9	91.0	91.0
770	91.1	91.1	91.2	91.2	91.2	91.3	91.3	91.4	91.4	91.5
780	91.5	91.6	91.6	91.7	91.7	91.8	91.8	91.9	91.9	92.0
790	92.0	92.1	92.1	92.2	92.2	92.3	92.3	92.4	92.4	92.5
800	92.5	92.6	92.6	92.7	92.7	92.8	92.8	92.9	92.9	93.0
810	93.0	93.1	93.1	93.2	93.2	93.3	93.3	93.4	93.4	93.5
820	93.5	93.6	93.6	93.7	93.7	93.8	93.8	93.9	93.9	94.0
830	94.0	94.0	94.1	94.1	94.2	94.2	94.3	94.3	94.4	94.4
840	94.5	94.5	94.6	94.6	94.7	94.7	94.8	94.8	94.9	94.9
850	95.0	95.0	95.1	95.1	95.2	95.2	95.3	95.3	95.4	95.4
860	95.5	95.5	95.6	95.6	95.7	95.7	95.8	95.8	95.9	95.9
870	96.0	96.0	96.1	96.1	96.2	96.2	96.3	96.3	96.4	96.4
880	96.5	96.6	96.6	96.7	96.7	96.8	96.8	96.9	96.9	97.0
890	97.0	97.1	97.1	97.2	97.2	97.3	97.3	97.4	97.4	97.5
900	97.5	97.6	97.6	97.7	97.7	97.8	97.8	97.9	97.9	98.0

TABLE A6.2 *Continued*

Digital Counter Setting	0	1	2	3	4	5	6	7	8	9
	Motor Octane Number									
910	98.0	98.1	98.2	98.2	98.3	98.3	98.4	98.4	98.5	98.5
920	98.6	98.6	98.7	98.8	98.8	98.9	98.9	99.0	99.0	99.1
930	99.1	99.2	99.2	99.3	99.3	99.4	99.5	99.5	99.6	99.6
940	99.7	99.7	99.8	99.8	99.9	99.9	99.9	100.0	100.0	100.1
950	100.2	100.2	100.3	100.4	100.4	100.5	100.6	100.7	100.7	100.8
960	100.9	101.0	101.1	101.2	101.2	101.3	101.4	101.5	101.6	101.6
970	101.7	101.8	101.8	101.9	102.0	102.0	102.1	102.2	102.2	102.3
980	102.4	102.6	102.6	102.7	102.8	102.8	102.9	103.0	103.2	103.3
990	103.3	103.4	103.6	103.6	103.8	104.0	104.0	104.1	104.2	104.2
1000	104.3	104.4	104.4	104.5	104.6	104.7	104.8	104.9	105.0	105.0
1010	105.1	105.2	105.3	105.3	105.4	105.5	105.6	105.7	105.8	105.9
1020	106.0	106.1	106.2	106.2	106.3	106.4	106.5	106.6	106.7	106.8
1030	106.9	107.0	107.1	107.2	107.3	107.4	107.5	107.6	107.7	107.8
1040	107.9	108.0	108.2	108.3	108.4	108.5	108.6	108.8	108.9	109.0
1050	109.2	109.2	109.3	109.4	109.6	109.7	109.8	109.9	110.0	110.2
1060	110.3	110.4	110.5	110.6	110.8	110.9	111.0	111.1	111.2	111.4
1070	111.5	111.6	111.7	111.8	112.0	112.1	112.2	112.3	112.4	112.5
1080	112.7	112.8	112.9	113.0	113.1	113.3	113.4	113.5	113.6	113.7
1090	113.8	113.9	114.0	114.2	114.3	114.4	114.5	114.6	114.8	114.9

TABLE A6.3 Guide Table for Standard Knock Intensity at Standard Barometric Pressure^A— $9\frac{1}{16}$ in. Venturi Dial Indicator Readings for Motor Octane Numbers

NOTE—See Tables A6.9 and A6.10 for dial indicator reading compensation for the applicable barometric pressure range between 104.7 kPa (31.0 in. Hg) and 94.6 kPa (28.0 in. Hg).

Motor Octane Number	0.0	0.1	0.2	0.3	0.4	0.5	0.6	0.7	0.8	0.9
	Dial Indicator Setting, in.									
40	0.891	0.891	0.890	0.890	0.889	0.889	0.888	0.888	0.887	0.887
41	0.887	0.886	0.886	0.886	0.885	0.885	0.884	0.884	0.883	0.883
42	0.883	0.882	0.882	0.881	0.881	0.880	0.889	0.880	0.879	0.879
43	0.878	0.878	0.877	0.877	0.876	0.876	0.876	0.875	0.875	0.874
44	0.874	0.873	0.873	0.872	0.872	0.871	0.871	0.871	0.870	0.870
45	0.869	0.869	0.868	0.868	0.867	0.867	0.866	0.866	0.865	0.865
46	0.864	0.864	0.864	0.863	0.863	0.862	0.862	0.861	0.861	0.860
47	0.860	0.859	0.859	0.858	0.858	0.857	0.857	0.856	0.856	0.855
48	0.855	0.854	0.854	0.853	0.853	0.852	0.852	0.851	0.851	0.850
49	0.850	0.849	0.849	0.848	0.848	0.847	0.847	0.846	0.846	0.845
50	0.845	0.844	0.844	0.843	0.842	0.842	0.841	0.841	0.840	0.840
51	0.839	0.839	0.838	0.838	0.837	0.837	0.836	0.836	0.835	0.835
52	0.834	0.833	0.833	0.832	0.832	0.831	0.831	0.830	0.830	0.829
53	0.828	0.828	0.827	0.827	0.826	0.826	0.825	0.824	0.824	0.823
54	0.823	0.822	0.822	0.821	0.820	0.820	0.819	0.819	0.818	0.818
55	0.817	0.817	0.816	0.815	0.815	0.814	0.814	0.813	0.812	0.812
56	0.811	0.811	0.810	0.810	0.809	0.808	0.808	0.807	0.806	0.806
57	0.805	0.805	0.804	0.804	0.803	0.802	0.802	0.801	0.800	0.800
58	0.799	0.799	0.798	0.797	0.797	0.796	0.795	0.795	0.794	0.794
59	0.793	0.793	0.792	0.791	0.791	0.790	0.789	0.789	0.788	0.788
60	0.787	0.786	0.786	0.785	0.784	0.784	0.783	0.783	0.782	0.781
61	0.780	0.780	0.779	0.779	0.778	0.777	0.776	0.776	0.775	0.775
62	0.774	0.773	0.773	0.772	0.771	0.771	0.770	0.769	0.769	0.768
63	0.767	0.767	0.766	0.765	0.765	0.764	0.763	0.763	0.762	0.761
64	0.760	0.760	0.759	0.759	0.758	0.757	0.756	0.756	0.755	0.755
65	0.754	0.753	0.752	0.752	0.751	0.750	0.750	0.749	0.748	0.748
66	0.747	0.746	0.745	0.745	0.744	0.743	0.742	0.742	0.741	0.740
67	0.739	0.739	0.738	0.737	0.736	0.736	0.735	0.734	0.733	0.733
68	0.732	0.731	0.730	0.730	0.729	0.728	0.727	0.727	0.726	0.725
69	0.724	0.723	0.722	0.722	0.721	0.720	0.719	0.718	0.718	0.717

TABLE A6.3 *Continued*

Motor Octane Number	0.0	0.1	0.2	0.3	0.4	0.5	0.6	0.7	0.8	0.9
	Dial Indicator Setting, in.									
70	0.716	0.715	0.714	0.714	0.713	0.712	0.711	0.710	0.709	0.709
71	0.708	0.707	0.706	0.705	0.704	0.703	0.702	0.702	0.701	0.700
72	0.699	0.698	0.697	0.696	0.696	0.695	0.694	0.693	0.692	0.691
73	0.690	0.689	0.688	0.687	0.686	0.685	0.684	0.683	0.683	0.682
74	0.681	0.680	0.679	0.678	0.677	0.676	0.675	0.674	0.673	0.672
75	0.671	0.670	0.669	0.668	0.667	0.666	0.665	0.664	0.663	0.662
76	0.661	0.660	0.659	0.658	0.657	0.656	0.655	0.654	0.653	0.652
77	0.651	0.650	0.649	0.648	0.647	0.745	0.644	0.643	0.642	0.640
78	0.639	0.638	0.637	0.636	0.634	0.633	0.632	0.631	0.630	0.629
79	0.627	0.626	0.625	0.624	0.622	0.621	0.620	0.619	0.617	0.616
80	0.615	0.614	0.612	0.611	0.610	0.609	0.608	0.607	0.605	0.604
81	0.603	0.602	0.600	0.599	0.598	0.597	0.596	0.594	0.593	0.592
82	0.591	0.590	0.588	0.587	0.586	0.584	0.583	0.582	0.581	0.580
83	0.578	0.577	0.576	0.575	0.573	0.572	0.571	0.570	0.568	0.567
84	0.566	0.564	0.563	0.562	0.560	0.559	0.558	0.556	0.555	0.554
85	0.552	0.551	0.549	0.548	0.546	0.545	0.544	0.542	0.541	0.540
86	0.538	0.537	0.536	0.534	0.533	0.532	0.530	0.529	0.528	0.526
87	0.524	0.523	0.521	0.520	0.519	0.517	0.516	0.514	0.513	0.511
88	0.510	0.509	0.507	0.506	0.504	0.503	0.501	0.500	0.498	0.497
89	0.496	0.494	0.493	0.491	0.490	0.488	0.487	0.485	0.484	0.483
90	0.481	0.480	0.478	0.477	0.475	0.474	0.472	0.471	0.470	0.468
91	0.467	0.465	0.464	0.462	0.461	0.459	0.458	0.457	0.455	0.454
92	0.452	0.451	0.449	0.448	0.446	0.445	0.444	0.442	0.441	0.439
93	0.438	0.436	0.435	0.433	0.432	0.431	0.429	0.428	0.426	0.425
94	0.423	0.422	0.420	0.419	0.418	0.416	0.415	0.413	0.412	0.410
95	0.409	0.408	0.406	0.405	0.403	0.402	0.400	0.399	0.398	0.396
96	0.395	0.393	0.392	0.391	0.389	0.388	0.387	0.385	0.384	0.382
97	0.381	0.380	0.378	0.377	0.376	0.374	0.373	0.371	0.370	0.369
98	0.367	0.366	0.365	0.363	0.362	0.361	0.359	0.358	0.357	0.355
99	0.354	0.353	0.352	0.350	0.349	0.348	0.346	0.345	0.344	0.342
100	0.340	0.339	0.338	0.337	0.336	0.335	0.334	0.333	0.332	0.331
101	0.331	0.330	0.329	0.328	0.327	0.326	0.325	0.324	0.323	0.322
102	0.321	0.320	0.319	0.318	0.317	0.317	0.316	0.315	0.314	0.313
103	0.312	0.311	0.311	0.310	0.309	0.309	0.308	0.308	0.307	0.307
104	0.306	0.305	0.304	0.303	0.302	0.301	0.300	0.299	0.298	0.298
105	0.297	0.296	0.295	0.294	0.293	0.292	0.291	0.291	0.290	0.289
106	0.288	0.288	0.287	0.286	0.285	0.284	0.284	0.283	0.282	0.282
107	0.281	0.280	0.280	0.279	0.278	0.277	0.277	0.276	0.275	0.275
108	0.274	0.274	0.273	0.272	0.272	0.271	0.270	0.270	0.269	0.269
109	0.268	0.267	0.267	0.266	0.265	0.265	0.264	0.264	0.263	0.263
110	0.262	0.262	0.261	0.260	0.260	0.259	0.258	0.258	0.257	0.257
111	0.256	0.255	0.255	0.254	0.254	0.253	0.253	0.252	0.251	0.251
112	0.250	0.249	0.249	0.248	0.248	0.247	0.246	0.246	0.245	0.245
113	0.244	0.243	0.243	0.242	0.242	0.241	0.240	0.240	0.239	0.238
114	0.238	0.237	0.237	0.236	0.235	0.235	0.234	0.234	0.233	0.232
115	0.232	0.231	0.231	0.230	0.230	0.229	0.228	0.228	0.227	0.227
116	0.226	0.225	0.225	0.224	0.224	0.223	0.222	0.222	0.221	0.221
117	0.220	0.219	0.219	0.218	0.218	0.217	0.216	0.206	0.215	0.215
118	0.214	0.214	0.213	0.212	0.212	0.211	0.211	0.210	0.210	0.209
119	0.209	0.208	0.208	0.207	0.206	0.206	0.205	0.204	0.203	0.203
120	0.202	0.202	0.201	0.200

^A Equivalent digital counter reading = (1.012-dial indicator reading) 1410.

**TABLE A6.4 Guide Table for Standard Knock Intensity at Standard Barometric Pressure^A—19/32 in. Venturi
Digital Counter Readings for Motor Octane Numbers**

NOTE—See Tables A6.9 and A6.10 for digital counter reading compensation for the applicable barometric pressure range between 94.6 kPa (28.0 in. Hg) and 84.4 kPa (25.0 in. Hg).

Motor Octane Number	0.0	0.1	0.2	0.3	0.4	0.5	0.6	0.7	0.8	0.9
	Digital Counter Setting									
40	45	45	46	47	48	48	49	49	50	51
41	52	53	54	54	55	55	56	56	57	58
42	59	60	61	61	62	62	63	63	64	65
43	66	67	68	68	69	69	70	70	71	72
44	73	74	75	75	76	76	77	78	79	79
45	80	81	82	83	84	85	85	86	86	87
46	87	88	89	90	91	92	92	93	94	94
47	95	96	97	98	99	99	100	100	101	102
48	103	104	105	106	106	107	108	109	110	110
49	111	111	112	113	114	115	116	117	117	118
50	119	120	121	121	122	123	124	125	126	127
51	127	128	129	130	131	132	133	133	134	135
52	136	137	138	138	139	140	141	142	143	144
53	144	145	146	147	148	149	150	151	151	152
54	153	154	155	156	157	158	159	160	161	161
55	162	163	164	165	166	167	168	169	170	171
56	172	173	174	175	176	177	178	179	179	180
57	181	182	183	184	185	186	187	188	189	190
58	191	192	193	194	195	196	197	198	199	200
59	201	202	203	204	205	206	207	209	210	211
60	212	213	214	215	216	217	219	220	220	221
61	223	224	225	226	227	228	229	230	231	232
62	233	234	235	237	238	239	240	241	243	244
63	245	246	247	248	250	251	252	253	254	255
64	257	258	259	260	261	262	264	265	266	267
65	268	269	271	272	274	275	276	278	279	280
66	281	282	283	285	286	288	289	290	291	292
67	293	295	296	298	299	300	302	303	305	306
68	307	309	310	312	313	314	315	316	317	319
69	320	321	323	324	326	327	329	330	331	333
70	334	336	337	338	340	341	343	344	345	347
71	348	350	351	352	354	355	357	359	361	362
72	364	365	367	368	369	371	372	374	375	376
73	378	379	381	383	385	386	388	389	391	392
74	393	395	397	399	400	402	403	405	406	408
75	410	412	413	415	416	418	420	422	423	424
76	426	428	430	431	433	434	436	438	440	441
77	443	444	446	448	450	451	453	455	457	458
78	460	461	463	465	467	468	470	472	474	475
79	477	479	481	482	484	486	488	489	491	493
80	495	497	499	501	502	504	506	508	510	512
81	513	515	517	519	520	522	524	526	528	530
82	532	534	536	537	539	541	543	545	547	548
83	550	552	554	556	558	560	562	564	566	568
84	570	572	574	576	578	580	582	584	585	587
85	589	591	593	595	597	599	601	603	605	607
86	609	611	613	615	617	619	621	623	625	627
87	629	631	633	634	636	638	640	642	644	647
88	649	651	653	655	657	659	661	663	665	667
89	669	671	673	675	677	679	681	683	685	687
90	689	691	693	695	697	699	702	704	706	708
91	710	712	714	716	718	720	722	724	726	728
92	730	732	734	736	738	740	742	744	746	748
93	750	752	754	757	759	761	763	765	767	769
94	771	773	775	777	779	781	783	785	787	789
95	791	793	795	797	799	801	803	805	807	809
96	811	813	815	817	819	821	823	825	827	829

TABLE A6.4 *Continued*

Motor Octane Number	0.0	0.1	0.2	0.3	0.4	0.5	0.6	0.7	0.8	0.9
	Digital Counter Setting									
97	830	832	834	836	838	840	842	844	846	848
98	850	852	854	856	857	859	861	863	865	867
99	869	870	872	874	876	877	879	881	883	885
100	887	890	892	894	895	897	898	900	902	904
101	905	907	909	911	913	915	917	919	921	922
102	924	926	927	928	930	932	933	935	937	939
103	940	941	942	943	945	946	948	949	950	952
104	953	955	956	957	959	960	961	962	963	964
105	965	966	967	968	969	970	971	972	973	974
106	974	975	976	977	978	979	980	981	982	983
107	984	985	986	987	987	988	989	990	991	992
108	993	993	994	995	995	996	997	998	999	1000
109	1001	1001	1002	1003	1004	1004	1005	1005	1006	1007
110	1008	1008	1009	1009	1010	1010	1011	1012	1012	1013
111	1013	1014	1014	1015	1016	1017	1018	1018	1019	1020
112	1021	1022	1023	1024	1025	1025	1026	1027	1028	1028
113	1029	1029	1030	1031	1032	1033	1034	1035	1036	1037
114	1038	1039	1041	1041	1042	1042	1043	1044	1045	1046
115	1046	1048	1048	1049	1049	1050	1053	1052	1053	1053
116	1055	1056	1056	1058	1059	1060	1060	1062	1063	1063
117	1065	1066	1066	1067	1067	1069	1070	1070	1072	1072
118	1073	1074	1074	1076	1076	1077	1077	1079	1079	1080
119	1080	1081	1081	1083	1083	1084	1086	1086	1087	1089
120	1089	1090	1090	1091

$$^A \text{Equivalent dial indicator reading} = 1.012 - \frac{\text{digital counter reading}}{1410}$$

TABLE A6.5 Guide Table for Standard Knock Intensity at Standard Barometric Pressure^A—19/32 in. Venturi Motor Octane Numbers for Digital Counter Readings

NOTE—See Tables A6.9 and A6.10 for digital counter reading compensation for the applicable barometric pressure range between 94.6 kPa (28.0 in. Hg) and 84.4 kPa (25.0 in. Hg).

Digital Counter Setting	0	1	2	3	4	5	6	7	8	9
	Motor Octane Number									
40					40.0	40.1	40.2	40.3	40.4	40.6
50	40.8	40.9	41.0	41.1	41.2	41.4	41.6	41.8	41.9	42.0
60	42.1	42.2	42.4	42.6	42.8	42.9	43.0	43.1	43.2	43.4
70	43.6	43.8	43.9	44.0	44.1	44.2	44.4	44.6	44.7	44.8
80	45.0	45.1	45.2	45.3	45.4	45.6	45.8	46.0	46.1	46.2
90	46.3	46.4	46.6	46.7	46.8	47.0	47.1	47.2	47.3	47.4
100	47.6	47.8	47.9	48.0	48.1	48.2	48.4	48.5	48.6	48.7
110	48.8	49.0	49.2	49.3	49.4	49.5	49.6	49.8	49.9	50.0
120	50.1	50.2	50.4	50.5	50.6	50.7	50.8	51.0	51.1	51.2
130	51.3	51.4	51.5	51.6	51.8	51.9	52.0	52.1	52.2	52.4
140	52.5	52.6	52.7	52.8	53.0	53.1	53.2	53.3	53.4	53.5
150	53.6	53.8	53.9	54.0	54.1	54.2	54.3	54.4	54.5	54.6
160	54.7	54.8	55.0	55.1	55.2	55.3	55.4	55.5	55.6	55.7
170	55.8	55.9	56.0	56.1	56.2	56.3	56.4	56.5	56.6	56.8
180	56.9	57.0	57.1	57.2	57.3	57.4	57.5	57.6	57.7	57.8
190	57.9	58.0	58.1	58.2	58.3	58.4	58.5	58.6	58.7	58.8
200	58.9	59.0	59.1	59.2	59.3	59.4	59.5	59.6	59.6	59.7
210	59.8	59.9	60.0	60.1	60.2	60.3	60.4	60.5	60.6	60.7
220	60.8	60.9	61.0	61.0	61.1	61.2	61.3	61.4	61.5	61.6
230	61.7	61.8	61.9	62.0	62.1	62.2	62.2	62.3	62.4	62.5
240	62.6	62.7	62.8	62.8	62.9	63.0	63.1	63.2	63.3	63.4
250	63.4	63.5	63.6	63.7	63.8	63.9	64.0	64.0	64.1	64.2
260	64.3	64.4	64.5	64.6	64.6	64.7	64.8	64.9	65.0	65.1

TABLE A6.5 *Continued*

Digital Counter Setting	0	1	2	3	4	5	6	7	8	9
	Motor Octane Number									
270	65.2	65.2	65.3	65.4	65.4	65.5	65.6	65.6	65.7	65.8
280	65.9	66.0	66.1	66.2	66.2	66.3	66.4	66.4	66.5	66.6
290	66.7	66.8	66.9	67.0	67.0	67.1	67.2	67.2	67.3	67.4
300	67.5	67.6	67.6	67.7	67.8	67.8	67.9	68.0	68.0	68.1
310	68.2	68.2	68.3	68.4	68.5	68.6	68.7	68.8	68.8	68.9
320	69.0	69.1	69.2	69.2	69.3	69.4	69.4	69.5	69.6	69.6
330	69.7	69.8	69.8	69.9	70.0	70.0	70.1	70.2	70.3	70.4
340	70.4	70.5	70.6	70.6	70.7	70.8	70.8	70.9	71.0	71.0
350	71.1	71.2	71.3	71.4	71.4	71.5	71.6	71.6	71.7	71.7
360	71.8	71.8	71.9	72.0	72.0	72.1	72.2	72.2	72.3	72.4
370	72.4	72.5	72.6	72.6	72.7	72.8	72.9	73.0	73.0	73.1
380	73.2	73.2	73.3	73.3	73.4	73.4	73.5	73.6	73.6	73.7
390	73.8	73.8	73.9	74.0	74.0	74.1	74.2	74.2	74.3	74.3
400	74.4	74.4	74.5	74.6	74.6	74.7	74.8	74.8	74.9	75.0
410	75.0	75.1	75.1	75.2	75.2	75.3	75.4	75.4	75.5	75.6
420	75.6	75.7	75.7	75.8	75.9	76.0	76.0	76.1	76.1	76.2
430	76.2	76.3	76.4	76.4	76.5	76.6	76.6	76.7	76.7	76.8
440	76.8	76.9	77.0	77.0	77.1	77.2	77.2	77.3	77.3	77.4
450	77.4	77.5	77.6	77.6	77.7	77.7	77.8	77.8	77.9	78.0
460	78.0	78.1	78.2	78.2	78.3	78.3	78.4	78.4	78.5	78.6
470	78.6	78.7	78.7	78.8	78.8	78.9	79.0	79.0	79.1	79.1
480	79.2	79.2	79.3	79.4	79.4	79.5	79.5	79.6	79.6	79.7
490	79.8	79.8	79.9	79.9	80.0	80.0	80.1	80.1	80.2	80.2
500	80.3	80.3	80.4	80.4	80.5	80.6	80.6	80.7	80.7	80.8
510	80.8	80.9	80.9	81.0	81.0	81.1	81.2	81.2	81.3	81.3
520	81.4	81.4	81.5	81.6	81.6	81.7	81.7	81.8	81.8	81.9
530	81.9	82.0	82.0	82.1	82.1	82.2	82.2	82.3	82.4	82.4
540	82.5	82.5	82.6	82.6	82.7	82.7	82.8	82.8	82.9	83.0
550	83.0	83.1	83.1	83.2	83.2	83.3	83.3	83.4	83.4	83.5
560	83.5	83.6	83.6	83.7	83.7	83.8	83.8	83.9	83.9	84.0
570	84.0	84.1	84.1	84.2	84.2	84.3	84.3	84.4	84.4	84.5
580	84.5	84.6	84.6	84.7	84.7	84.8	84.8	84.9	85.0	85.0
590	85.1	85.1	85.2	85.2	85.3	85.3	85.4	85.4	85.5	85.5
600	85.6	85.6	85.7	85.7	85.8	85.8	85.9	85.9	86.0	86.0
610	86.1	86.1	86.2	86.2	86.3	86.3	86.4	86.4	86.5	86.5
620	86.6	86.6	86.7	86.7	86.8	86.8	86.9	86.9	87.0	87.0
630	87.1	87.1	87.2	87.2	87.3	87.3	87.4	87.4	87.5	87.5
640	87.6	87.6	87.7	87.7	87.8	87.8	87.9	87.9	88.0	88.0
650	88.1	88.1	88.2	88.2	88.3	88.3	88.4	88.4	88.5	88.5
660	88.6	88.6	88.7	88.7	88.8	88.8	88.9	88.9	89.0	89.0
670	89.1	89.1	89.2	89.2	89.3	89.3	89.4	89.4	89.5	89.5
680	89.6	89.6	89.7	89.7	89.8	89.8	89.9	89.9	90.0	90.0
690	90.1	90.1	90.2	90.2	90.3	90.3	90.4	90.4	90.4	90.5
700	90.5	90.6	90.6	90.7	90.7	90.8	90.8	90.9	90.9	91.0
710	91.0	91.1	91.1	91.2	91.2	91.3	91.3	91.4	91.4	91.5
720	91.5	91.6	91.6	91.7	91.7	91.8	91.8	91.9	91.9	92.0
730	92.0	92.1	92.1	92.2	92.2	92.3	92.3	92.4	92.4	92.5
740	92.5	92.6	92.6	92.7	92.7	92.8	92.8	92.9	92.9	93.0
750	93.0	93.1	93.1	93.2	93.2	93.3	93.3	93.4	93.4	93.5
760	93.5	93.5	93.6	93.6	93.7	93.7	93.8	93.8	93.9	93.9
770	94.0	94.0	94.1	94.1	94.2	94.2	94.3	94.3	94.4	94.4
780	94.5	94.5	94.6	94.6	94.7	94.7	94.8	94.8	94.9	94.9
790	95.0	95.0	95.1	95.1	95.2	95.2	95.3	95.3	95.4	95.4
800	95.5	95.5	95.6	95.6	95.7	95.7	95.8	95.8	95.9	95.9
810	96.0	96.0	96.1	96.1	96.2	96.2	96.3	96.3	96.4	96.4
820	96.5	96.5	96.6	96.6	96.7	96.7	96.8	96.8	96.9	96.9
830	97.0	97.0	97.1	97.1	97.2	97.2	97.3	97.3	97.4	97.4
840	97.5	97.5	97.6	97.6	97.7	97.7	97.8	97.8	97.9	97.9
850	98.0	98.0	98.1	98.1	98.2	98.2	98.3	98.4	98.4	98.5
860	98.5	98.6	98.6	98.7	98.7	98.8	98.8	98.9	99.0	99.0

TABLE A6.5 *Continued*

Digital Counter Setting	0	1	2	3	4	5	6	7	8	9
	Motor Octane Number									
870	99.1	99.2	99.2	99.3	99.3	99.4	99.4	99.5	99.5	99.6
880	99.6	99.7	99.7	99.8	99.8	99.9	99.9	100.0	100.0	100.1
890	100.1	100.2	100.2	100.3	100.3	100.4	100.4	100.5	100.6	100.6
900	100.7	100.7	100.8	100.8	100.9	101.0	101.0	101.1	101.1	101.2
910	101.2	101.3	101.3	101.4	101.4	101.5	101.5	101.6	101.6	101.7
920	101.8	101.8	101.9	102.0	102.0	102.1	102.1	102.2	102.3	102.4
930	102.4	102.5	102.5	102.6	102.6	102.7	102.8	102.8	102.9	102.9
940	103.0	103.1	103.2	103.3	103.4	103.4	103.5	103.6	103.6	103.7
950	103.8	103.8	103.9	104.0	104.0	104.1	104.2	104.3	104.4	104.4
960	104.5	104.6	104.7	104.8	104.9	105.0	105.1	105.2	105.3	105.4
970	105.5	105.6	105.7	105.8	106.0	106.1	106.2	106.3	106.4	106.5
980	106.6	106.7	106.8	106.9	107.0	107.1	107.2	107.4	107.5	107.6
990	107.7	107.8	107.9	108.0	108.2	108.4	108.5	108.6	108.7	108.8
1000	108.9	109.0	109.2	109.3	109.4	109.6	109.8	109.9	110.0	110.2
1010	110.4	110.6	110.8	111.0	111.2	111.3	111.4	111.5	111.6	111.8
1020	111.9	112.0	112.1	112.2	112.3	112.4	112.6	112.7	112.8	113.0
1030	113.2	113.3	113.4	113.5	113.6	113.7	113.8	113.9	114.0	114.1
1040	114.2	114.3	114.4	114.6	114.7	114.8	115.0	115.1	115.2	115.3
1050	115.4	115.5	115.6	115.8	116.0	116.1	116.2	116.2	116.3	116.4
1060	116.5	116.6	116.7	116.8	117.0	117.1	117.2	117.3	117.4	117.5
1070	117.6	117.8	117.9	118.0	118.1	118.2	118.4	118.6	118.7	118.8
1080	119.0	119.1	119.2	119.4	119.5	119.6	119.7	119.8	119.9	120.0
1090	120.1	120.2	120.3							

$$^A \text{ Equivalent dial indicator reading} = 1.012 - \frac{\text{digital counter reading}}{1410}$$

TABLE A6.6 Guide Table for Standard Knock Intensity at Standard Barometric Pressure^A—19/32 in. Venturi Dial Indicator Readings for Motor Octane Numbers

NOTE—See Tables A6.9 and A6.10 for dial indicator reading compensation for the applicable barometric pressure range between 94.6 kPa (28.0 in. Hg) and 84.4 kPa (25.0 in. Hg).

Motor Octane Number	0.0	0.1	0.2	0.3	0.4	0.5	0.6	0.7	0.8	0.9
	Dial Indicator Setting, in.									
40	0.980	0.980	0.979	0.979	0.978	0.978	0.977	0.977	0.976	0.976
41	0.975	0.975	0.974	0.974	0.973	0.973	0.972	0.972	0.971	0.971
42	0.970	0.970	0.969	0.969	0.968	0.968	0.967	0.967	0.966	0.966
43	0.965	0.965	0.964	0.964	0.963	0.963	0.962	0.962	0.961	0.961
44	0.960	0.960	0.959	0.959	0.958	0.958	0.957	0.957	0.956	0.956
45	0.955	0.954	0.954	0.953	0.953	0.952	0.952	0.951	0.951	0.950
46	0.950	0.949	0.949	0.948	0.948	0.947	0.947	0.946	0.945	0.945
47	0.944	0.944	0.943	0.943	0.942	0.942	0.941	0.941	0.940	0.940
48	0.939	0.938	0.938	0.937	0.937	0.936	0.936	0.935	0.934	0.934
49	0.933	0.933	0.932	0.932	0.931	0.930	0.930	0.929	0.929	0.928
50	0.928	0.927	0.926	0.926	0.925	0.925	0.924	0.923	0.923	0.922
51	0.922	0.921	0.920	0.920	0.919	0.919	0.918	0.918	0.917	0.916
52	0.916	0.915	0.914	0.914	0.913	0.913	0.912	0.911	0.911	0.910
53	0.910	0.909	0.908	0.908	0.907	0.906	0.906	0.905	0.905	0.904
54	0.903	0.903	0.902	0.901	0.901	0.900	0.899	0.899	0.898	0.898
55	0.897	0.896	0.896	0.895	0.894	0.894	0.893	0.892	0.892	0.891
56	0.890	0.890	0.889	0.888	0.887	0.887	0.886	0.885	0.885	0.884
57	0.883	0.883	0.882	0.881	0.881	0.880	0.879	0.879	0.878	0.877
58	0.876	0.876	0.875	0.874	0.874	0.873	0.872	0.871	0.871	0.870
59	0.869	0.869	0.868	0.867	0.866	0.866	0.865	0.864	0.863	0.863
60	0.862	0.861	0.860	0.860	0.859	0.858	0.857	0.856	0.856	0.855
61	0.854	0.953	0.853	0.852	0.851	0.850	0.850	0.849	0.848	0.847
62	0.846	0.846	0.845	0.844	0.843	0.842	0.842	0.841	0.840	0.839
63	0.838	0.837	0.837	0.836	0.835	0.834	0.833	0.832	0.832	0.831
64	0.830	0.829	0.828	0.827	0.827	0.826	0.825	0.824	0.823	0.822

TABLE A6.6 *Continued*

Motor Octane Number	0.0	0.1	0.2	0.3	0.4	0.5	0.6	0.7	0.8	0.9
	Dial Indicator Setting, in.									
65	0.822	0.821	0.820	0.819	0.818	0.817	0.816	0.815	0.814	0.814
66	0.813	0.812	0.811	0.810	0.809	0.808	0.807	0.806	0.805	0.805
67	0.804	0.803	0.802	0.801	0.800	0.799	0.798	0.797	0.796	0.795
68	0.794	0.793	0.792	0.791	0.790	0.790	0.789	0.788	0.787	0.786
69	0.785	0.784	0.783	0.782	0.781	0.780	0.779	0.778	0.777	0.776
70	0.775	0.774	0.773	0.772	0.771	0.770	0.769	0.768	0.767	0.766
71	0.765	0.764	0.763	0.762	0.761	0.760	0.759	0.758	0.756	0.755
72	0.754	0.753	0.752	0.751	0.750	0.749	0.748	0.747	0.746	0.745
73	0.744	0.743	0.742	0.740	0.739	0.738	0.737	0.736	0.735	0.734
74	0.733	0.732	0.730	0.729	0.728	0.727	0.726	0.725	0.724	0.723
75	0.721	0.720	0.719	0.718	0.717	0.716	0.714	0.713	0.712	0.711
76	0.710	0.709	0.707	0.706	0.705	0.704	0.703	0.702	0.700	0.699
77	0.698	0.697	0.696	0.694	0.693	0.692	0.691	0.690	0.688	0.687
78	0.686	0.685	0.683	0.682	0.681	0.680	0.679	0.677	0.676	0.675
79	0.674	0.672	0.671	0.670	0.669	0.667	0.666	0.665	0.664	0.662
80	0.661	0.660	0.658	0.657	0.656	0.655	0.653	0.652	0.651	0.649
81	0.648	0.647	0.645	0.644	0.643	0.642	0.640	0.639	0.638	0.636
82	0.635	0.634	0.632	0.631	0.630	0.628	0.627	0.626	0.624	0.623
83	0.622	0.620	0.619	0.618	0.616	0.615	0.613	0.612	0.611	0.609
84	0.608	0.607	0.605	0.604	0.602	0.601	0.600	0.598	0.597	0.596
85	0.594	0.593	0.591	0.590	0.588	0.587	0.586	0.584	0.583	0.582
86	0.580	0.579	0.577	0.576	0.575	0.573	0.572	0.570	0.569	0.568
87	0.566	0.565	0.563	0.562	0.561	0.559	0.558	0.556	0.555	0.553
88	0.552	0.551	0.549	0.548	0.546	0.545	0.543	0.542	0.540	0.539
89	0.538	0.536	0.535	0.533	0.532	0.530	0.529	0.527	0.526	0.525
90	0.523	0.522	0.520	0.519	0.517	0.516	0.514	0.513	0.512	0.510
91	0.509	0.507	0.506	0.504	0.503	0.501	0.500	0.499	0.497	0.496
92	0.494	0.493	0.491	0.490	0.488	0.487	0.486	0.484	0.483	0.481
93	0.480	0.478	0.477	0.475	0.474	0.473	0.471	0.470	0.468	0.467
94	0.465	0.464	0.462	0.461	0.460	0.458	0.457	0.455	0.454	0.452
95	0.451	0.450	0.448	0.447	0.445	0.444	0.442	0.441	0.440	0.438
96	0.437	0.435	0.434	0.433	0.431	0.430	0.429	0.427	0.426	0.424
97	0.423	0.422	0.420	0.419	0.418	0.416	0.415	0.413	0.412	0.411
98	0.409	0.408	0.407	0.405	0.404	0.403	0.401	0.400	0.399	0.397
99	0.396	0.395	0.394	0.392	0.391	0.390	0.388	0.387	0.386	0.385
100	0.383	0.381	0.379	0.378	0.377	0.376	0.375	0.374	0.372	0.371
101	0.370	0.369	0.367	0.366	0.364	0.363	0.362	0.360	0.359	0.358
102	0.357	0.355	0.355	0.354	0.352	0.351	0.350	0.349	0.347	0.346
103	0.345	0.345	0.344	0.343	0.342	0.341	0.340	0.339	0.338	0.337
104	0.336	0.335	0.334	0.333	0.332	0.331	0.330	0.330	0.329	0.328
105	0.328	0.327	0.326	0.325	0.325	0.324	0.323	0.323	0.322	0.321
106	0.321	0.321	0.320	0.319	0.318	0.318	0.317	0.316	0.316	0.315
107	0.314	0.313	0.313	0.312	0.312	0.311	0.311	0.310	0.309	0.308
108	0.308	0.308	0.307	0.306	0.306	0.306	0.305	0.304	0.303	0.303
109	0.302	0.302	0.301	0.301	0.300	0.300	0.299	0.299	0.299	0.298
110	0.297	0.297	0.296	0.296	0.296	0.296	0.295	0.294	0.294	0.294
111	0.294	0.293	0.293	0.292	0.291	0.291	0.290	0.290	0.289	0.289
112	0.288	0.287	0.286	0.286	0.285	0.285	0.284	0.284	0.283	0.283
113	0.282	0.282	0.282	0.281	0.280	0.279	0.279	0.278	0.277	0.277
114	0.276	0.275	0.274	0.274	0.273	0.273	0.272	0.272	0.271	0.270
115	0.270	0.269	0.269	0.268	0.268	0.267	0.266	0.266	0.265	0.265
116	0.264	0.263	0.263	0.262	0.261	0.260	0.260	0.259	0.258	0.258
117	0.257	0.256	0.256	0.255	0.255	0.254	0.253	0.253	0.252	0.252
118	0.251	0.250	0.250	0.249	0.249	0.248	0.248	0.247	0.247	0.246
119	0.246	0.245	0.245	0.244	0.244	0.243	0.242	0.242	0.241	0.240
120	0.240	0.239	0.239	0.238

^A Equivalent digital counter reading = (1.012 – dial indicator reading) 1410.

**TABLE A6.7 Guide Table for Standard Knock Intensity at Standard Barometric Pressure^A— $\frac{3}{4}$ in. Venturi
Digital Counter Readings for Motor Octane Numbers**

NOTE—See Tables A6.9 and A6.10 for digital counter reading compensation for the applicable barometric pressure range from 84.4 kPa (25.0 in. Hg) and lower.

Motor Octane Number	0.0	0.1	0.2	0.3	0.4	0.5	0.6	0.7	0.8	0.9
	Digital Counter Setting									
40
41	0	0	1	2	3	3	4	4
42	5	6	7	7	8	9	10	10	11	11
43	12	13	14	15	16	16	17	17	18	18
44	19	20	21	22	23	23	24	24	25	26
45	27	28	28	29	30	31	31	32	33	34
46	34	35	35	36	37	38	38	39	40	41
47	42	43	44	44	45	45	46	47	48	48
48	49	50	51	52	53	54	54	55	56	56
49	57	58	59	60	61	62	62	63	63	64
50	65	66	67	68	69	70	71	72	72	73
51	74	75	76	76	77	78	79	79	80	81
52	82	83	84	85	86	86	87	88	89	90
53	91	92	93	93	94	95	96	97	98	99
54	100	101	102	103	103	104	105	106	107	108
55	109	110	110	111	112	113	114	115	116	117
56	118	119	120	121	122	123	124	125	126	127
57	128	129	130	131	132	133	134	135	136	137
58	138	139	140	141	141	142	144	145	146	147
59	148	149	150	151	152	153	154	155	156	157
60	158	159	160	161	162	164	165	166	167	168
61	169	170	171	172	173	174	175	176	178	179
62	180	181	182	183	185	186	187	188	189	190
63	192	193	194	195	196	197	199	200	201	202
64	203	204	206	207	208	209	210	212	213	214
65	215	216	217	219	220	221	223	224	225	226
66	227	228	230	231	233	234	235	237	238	239
67	240	241	243	244	245	247	248	250	251	252
68	254	255	257	258	259	260	261	262	264	265
69	266	268	269	271	272	274	275	276	278	279
70	281	282	283	285	286	288	289	290	292	293
71	295	296	298	299	300	302	303	305	307	309
72	310	312	313	314	316	317	319	320	321	323
73	324	326	327	329	331	333	334	336	337	338
74	340	341	343	345	347	348	350	351	352	354
75	356	358	360	361	362	364	366	368	369	371
76	372	374	376	378	379	381	382	384	386	388
77	389	391	393	395	396	398	399	401	403	405
78	406	408	410	412	413	415	417	419	420	422
79	424	426	427	429	430	432	434	436	438	440
80	441	443	445	447	448	450	452	454	456	458
81	460	461	463	465	467	469	471	472	474	476
82	478	480	482	484	485	487	489	491	493	495
83	497	499	501	502	504	506	508	510	512	514
84	516	518	520	522	524	526	528	530	532	534
85	536	538	540	541	543	545	547	549	551	553
86	555	557	559	561	563	565	567	569	571	573
87	575	577	579	581	583	585	587	589	591	593
88	595	597	599	601	603	605	607	609	612	614
89	615	617	619	621	623	626	628	630	632	634
90	636	638	640	642	644	646	648	650	652	654
91	656	658	660	662	664	666	668	670	672	674
92	676	678	681	683	685	687	689	691	693	695
93	697	699	701	703	705	707	709	711	713	715
94	717	719	721	723	725	727	729	731	733	735
95	737	739	741	743	745	747	750	752	754	756
96	758	760	761	763	765	767	769	771	773	775
97	777	779	781	783	785	787	789	791	792	794

TABLE A6.7 *Continued*

Motor Octane Number	0.0	0.1	0.2	0.3	0.4	0.5	0.6	0.7	0.8	0.9
	Digital Counter Setting									
98	796	798	800	802	804	806	808	809	811	813
99	815	816	818	820	822	824	826	828	829	831
100	833	836	839	840	842	843	845	847	849	851
101	852	853	855	857	860	862	863	865	867	869
102	870	872	874	875	876	878	880	882	884	885
103	886	887	888	890	891	893	894	895	897	898
104	900	901	902	904	905	906	907	908	909	911
105	912	913	914	915	916	916	917	918	919	920
106	921	922	923	924	925	925	926	927	928	929
107	930	931	932	933	934	935	936	936	937	938
108	939	939	940	941	942	943	944	945	946	946
109	947	948	948	949	949	950	951	952	953	953
110	954	955	955	956	956	957	957	958	958	959
111	959	960	961	962	962	963	964	965	966	966
112	967	968	969	970	971	971	972	973	974	975
113	976	976	977	977	978	979	980	981	982	983
114	984	985	986	986	987	988	989	990	991	992
115	993	994	994	995	997	997	998	1000	1001	1001
116	1003	1004	1004	1005	1005	1007	1008	1008	1010	1010
117	1011	1012	1012	1014	1014	1015	1017	1017	1018	1018
118	1019	1021	1021	1022	1022	1024	1024	1025	1025	1026
119	1026	1028	1028	1029	1029	1031	1032	1032	1034	1034
120	1035	1035	1036	1038

$$^A \text{ Equivalent dial indicator reading} = 1.012 - \frac{\text{digital counter reading}}{1410}$$

TABLE A6.8 Guide Table for Standard Knock Intensity at Standard Barometric Pressure^A— $\frac{3}{4}$ in. Venturi Dial Indicator Readings for Motor Octane Numbers

NOTE—See Tables A6.9 and A6.10 for dial indicator reading compensation for the applicable barometric pressure range from 84.4 kPa (25.0 in. Hg) and lower.

Motor Octane Number	0.0	0.1	0.2	0.3	0.4	0.5	0.6	0.7	0.8	0.9
	Dial Indicator, in.									
40	1.018	1.018	1.017	1.017	1.016	1.016	1.015	1.015	1.014	1.014
41	1.013	1.013	1.012	1.012	1.011	1.011	1.010	1.010	1.009	1.009
42	1.008	1.008	1.007	1.007	1.006	1.006	1.005	1.005	1.004	1.004
43	1.003	1.003	1.002	1.002	1.001	1.001	1.000	1.000	0.999	0.999
44	0.998	0.998	0.997	0.997	0.996	0.996	0.995	0.995	0.994	0.994
45	0.993	0.992	0.992	0.991	0.991	0.990	0.990	0.989	0.989	0.988
46	0.988	0.987	0.987	0.986	0.986	0.985	0.985	0.984	0.983	0.983
47	0.982	0.982	0.981	0.981	0.980	0.980	0.979	0.979	0.978	0.978
48	0.977	0.976	0.976	0.975	0.975	0.974	0.974	0.973	0.972	0.972
49	0.971	0.971	0.970	0.970	0.969	0.968	0.968	0.967	0.967	0.966
50	0.966	0.965	0.964	0.964	0.963	0.963	0.962	0.961	0.961	0.960
51	0.960	0.959	0.958	0.958	0.957	0.957	0.956	0.956	0.955	0.954
52	0.954	0.953	0.952	0.952	0.951	0.951	0.950	0.949	0.949	0.948
53	0.948	0.947	0.946	0.946	0.945	0.944	0.944	0.943	0.943	0.942
54	0.941	0.941	0.940	0.939	0.939	0.938	0.937	0.937	0.936	0.936
55	0.935	0.934	0.934	0.933	0.932	0.932	0.931	0.930	0.930	0.929
56	0.928	0.928	0.927	0.926	0.925	0.925	0.924	0.923	0.923	0.922
57	0.921	0.921	0.920	0.919	0.919	0.918	0.917	0.917	0.916	0.915
58	0.914	0.914	0.913	0.912	0.912	0.911	0.910	0.909	0.909	0.908
59	0.907	0.907	0.906	0.905	0.904	0.904	0.903	0.902	0.901	0.901
60	0.900	0.899	0.898	0.898	0.897	0.896	0.895	0.894	0.894	0.893
61	0.892	0.891	0.891	0.890	0.889	0.888	0.888	0.887	0.886	0.885
62	0.884	0.884	0.883	0.882	0.881	0.880	0.880	0.879	0.878	0.877
63	0.876	0.875	0.875	0.874	0.873	0.872	0.871	0.870	0.870	0.869

TABLE A6.8 *Continued*

Motor Octane Number	0.0	0.1	0.2	0.3	0.4	0.5	0.6	0.7	0.8	0.9
	Dial Indicator, in.									
64	0.868	0.867	0.866	0.865	0.865	0.864	0.863	0.862	0.861	0.860
65	0.860	0.859	0.858	0.857	0.856	0.855	0.854	0.853	0.852	0.852
66	0.851	0.850	0.849	0.848	0.847	0.846	0.845	0.844	0.843	0.843
67	0.842	0.841	0.840	0.839	0.838	0.837	0.836	0.835	0.834	0.833
68	0.832	0.831	0.830	0.829	0.828	0.828	0.827	0.826	0.825	0.824
69	0.823	0.822	0.821	0.820	0.819	0.818	0.817	0.816	0.815	0.814
70	0.813	0.812	0.811	0.810	0.809	0.808	0.807	0.806	0.805	0.804
71	0.803	0.802	0.801	0.800	0.799	0.798	0.797	0.796	0.794	0.793
72	0.792	0.791	0.790	0.789	0.788	0.787	0.786	0.785	0.784	0.783
73	0.782	0.781	0.780	0.778	0.777	0.776	0.775	0.774	0.773	0.772
74	0.771	0.770	0.768	0.767	0.766	0.765	0.764	0.763	0.762	0.761
75	0.759	0.758	0.757	0.756	0.755	0.754	0.752	0.751	0.750	0.749
76	0.748	0.747	0.745	0.744	0.743	0.742	0.741	0.740	0.738	0.737
77	0.736	0.735	0.734	0.732	0.731	0.730	0.729	0.728	0.726	0.725
78	0.724	0.723	0.721	0.720	0.719	0.718	0.717	0.715	0.714	0.713
79	0.712	0.710	0.709	0.708	0.707	0.705	0.704	0.703	0.702	0.700
80	0.699	0.698	0.696	0.695	0.694	0.693	0.691	0.690	0.689	0.687
81	0.686	0.685	0.683	0.682	0.681	0.680	0.678	0.677	0.676	0.674
82	0.673	0.672	0.670	0.669	0.668	0.666	0.665	0.664	0.662	0.661
83	0.660	0.658	0.657	0.656	0.654	0.653	0.651	0.650	0.649	0.647
84	0.646	0.645	0.643	0.642	0.640	0.639	0.638	0.636	0.635	0.634
85	0.632	0.631	0.629	0.628	0.627	0.625	0.624	0.622	0.621	0.620
86	0.618	0.617	0.615	0.614	0.613	0.611	0.610	0.608	0.607	0.606
87	0.604	0.603	0.601	0.600	0.599	0.597	0.596	0.594	0.593	0.591
88	0.590	0.589	0.587	0.586	0.584	0.583	0.581	0.580	0.578	0.577
89	0.576	0.574	0.573	0.571	0.570	0.568	0.567	0.565	0.564	0.563
90	0.561	0.560	0.558	0.557	0.555	0.554	0.552	0.551	0.550	0.548
91	0.547	0.545	0.544	0.542	0.541	0.539	0.538	0.537	0.535	0.534
92	0.532	0.531	0.529	0.528	0.526	0.525	0.524	0.522	0.521	0.519
93	0.518	0.516	0.515	0.513	0.512	0.511	0.509	0.508	0.506	0.505
94	0.503	0.502	0.500	0.499	0.498	0.496	0.495	0.493	0.492	0.490
95	0.489	0.488	0.486	0.485	0.483	0.482	0.480	0.479	0.478	0.476
96	0.475	0.473	0.472	0.471	0.469	0.468	0.467	0.465	0.464	0.462
97	0.461	0.460	0.458	0.457	0.456	0.454	0.453	0.451	0.450	0.449
98	0.447	0.446	0.445	0.443	0.442	0.441	0.439	0.438	0.437	0.435
99	0.434	0.433	0.432	0.430	0.429	0.428	0.426	0.425	0.424	0.423
100	0.421	0.419	0.417	0.416	0.415	0.414	0.413	0.411	0.410	0.408
101	0.408	0.407	0.406	0.404	0.402	0.401	0.400	0.399	0.397	0.396
102	0.395	0.394	0.392	0.391	0.391	0.389	0.388	0.386	0.385	0.384
103	0.384	0.383	0.382	0.381	0.380	0.379	0.378	0.377	0.376	0.375
104	0.374	0.373	0.372	0.371	0.370	0.369	0.369	0.368	0.367	0.366
105	0.365	0.364	0.364	0.363	0.362	0.362	0.362	0.361	0.360	0.360
106	0.359	0.358	0.357	0.357	0.356	0.356	0.355	0.355	0.354	0.353
107	0.352	0.352	0.351	0.350	0.350	0.349	0.348	0.348	0.347	0.347
108	0.346	0.346	0.345	0.345	0.344	0.343	0.342	0.342	0.341	0.341
109	0.340	0.340	0.340	0.339	0.339	0.338	0.338	0.337	0.336	0.336
110	0.335	0.335	0.335	0.334	0.334	0.333	0.333	0.333	0.333	0.332
111	0.332	0.331	0.330	0.330	0.330	0.329	0.328	0.328	0.327	0.327
112	0.326	0.325	0.325	0.324	0.323	0.323	0.323	0.322	0.321	0.321
113	0.320	0.320	0.319	0.319	0.318	0.318	0.317	0.316	0.316	0.315
114	0.314	0.313	0.313	0.313	0.312	0.311	0.311	0.310	0.309	0.308
115	0.308	0.307	0.307	0.306	0.305	0.305	0.304	0.303	0.302	0.302
116	0.301	0.300	0.300	0.299	0.299	0.298	0.297	0.297	0.296	0.296
117	0.295	0.294	0.294	0.293	0.293	0.292	0.291	0.291	0.290	0.290
118	0.289	0.288	0.288	0.287	0.287	0.286	0.286	0.285	0.285	0.284
119	0.284	0.283	0.283	0.282	0.282	0.281	0.280	0.280	0.279	0.279
120	0.278	0.278	0.277	0.276

^A Equivalent digital counter reading = (1.012 – dial indicator reading) 1410.

TABLE A6.9 Compensation for Guide Table Cylinder Height for Barometric Pressures Below 29.92 in. Hg^A

NOTE 1—This table was developed for barometric pressure in terms of inches and tenths of inches of Hg. Conversion to kPa values is only shown for the whole number in. Hg pressure listings.

NOTE 2—To determine the cylinder height measure that provides standard K.I. at a prevailing barometric pressure below 29.92 in. Hg:

ADD the listed digital counter correction to the guide table digital counter reading.

SUBTRACT the listed dial indicator correction reading from the guide table dial indicator reading.

NOTE 3—To convert an observed engine cylinder height measure at the prevailing barometric pressure to that of 29.92 in. Hg:

SUBTRACT the listed digital counter correction from the observed engine digital counter reading.

ADD the listed dial indicator correction to the observed engine dial indicator reading.

Barometric Pressure, in. Hg (kPa)		0.0	0.1	0.2	0.3	0.4	0.5	0.6	0.7	0.8	0.9
22.0 (74.3)	Digital counter correction	336	331	327	323	319	314	310	306	302	296
	Dial indicator correction	0.238	0.235	0.232	0.229	0.226	0.223	0.220	0.217	0.214	0.211
23.0 (77.7)	Digital counter correction	293	289	285	281	276	272	268	264	259	255
	Dial indicator correction	0.208	0.205	0.202	0.199	0.196	0.193	0.190	0.187	0.184	0.181
24.0 (77.7)	Digital counter correction	251	247	243	238	234	230	226	221	217	213
	Dial indicator correction	0.178	0.175	0.172	0.169	0.166	0.163	0.160	0.157	0.154	0.151
25.0 (84.4)	Digital counter correction	209	204	200	196	192	188	183	179	175	171
	Dial indicator correction	0.148	0.145	0.142	0.139	0.136	0.133	0.130	0.127	0.124	0.121
26.0 (87.8)	Digital counter correction	166	162	158	154	149	145	141	137	133	128
	Dial indicator correction	0.118	0.115	0.112	0.109	0.106	0.103	0.100	0.097	0.094	0.091
27.0 (91.2)	Digital counter correction	124	120	116	111	107	103	99	94	90	86
	Dial indicator correction	0.086	0.085	0.082	0.079	0.076	0.073	0.070	0.067	0.064	0.061
28.0 (94.6)	Digital counter correction	82	78	73	69	65	61	56	52	48	44
	Dial indicator correction	0.058	0.055	0.052	0.049	0.046	0.043	0.040	0.037	0.034	0.031
29.0 (97.9)	Digital counter correction	39	35	31	27	23	18	14	10	6	1
	Dial indicator correction	0.028	0.025	0.022	0.019	0.016	0.013	0.010	0.007	0.004	0.001

^A To set the digital counter so that the lower counter reading is compensated to 29.92 in. Hg, position the selector knob so that the lower counter is disengaged (positions other than 1), change the engine cylinder height so that the upper and lower counter readings differ by the value listed in this table for the prevailing barometric pressure, and then reposition the selector knob to position 1.

Upper digital counter reading must be greater than the lower compensated reading for barometric pressures numerically less than 29.92 in. Hg.

Upper digital counter reading must be less than the lower compensated reading for barometric pressures numerically greater than 29.92 in. Hg.

TABLE A6.10 Compensation for Guide Table Cylinder Height for Barometric Pressures Above 29.92 in Hg^A

NOTE 1—To determine the cylinder height measure that provides standard K.I. at a prevailing barometric pressure above 29.92 in. Hg:

SUBTRACT the listed dial digital counter correction from the guide table digital counter reading.

ADD the listed dial indicator correction to the guide table dial indicator reading.

NOTE 2—To convert an observed engine cylinder height measure at the prevailing barometric pressure to that of 29.92 in. Hg:

ADD the listed digital counter correction to the observed engine digital counter reading.

SUBTRACT the listed dial indicator correction from the observed engine dial indicator reading.

Barometric Pressure, in. Hg (kPa)		0.0	0.1	0.2	0.3	0.4	0.5	0.6	0.7	0.8	0.9
30.0 (101.3)	Digital counter correction	3	7	11	16	20	24	28	32	37	41
	Dial indicator correction	0.002	0.005	0.008	0.011	0.014	0.017	0.020	0.023	0.026	0.029

^A To set the digital counter so that the lower counter reading is compensated to 29.92 in. Hg, position the selector knob so that the lower counter is disengaged (positions other than 1), change the engine cylinder height so that the upper and lower counter readings differ by the value listed in this table for the prevailing barometric pressure, and then reposition the selector knob to position 1.

Upper digital counter reading must be less than the lower compensated reading for barometric pressures numerically greater than 29.92 in. Hg.

APPENDIXES

(Nonmandatory Information)

X1. VOLUMETRIC REFERENCE FUEL BLENDING APPARATUS AND PROCEDURES

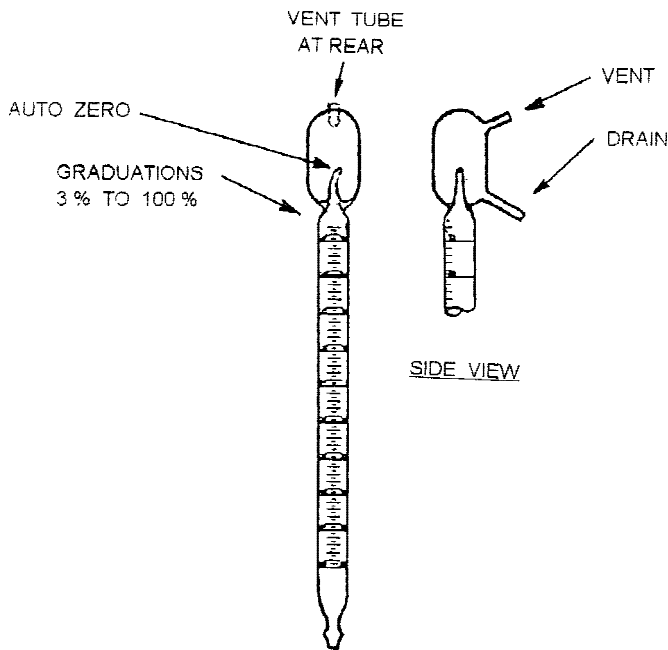

FIG. X1.1 Typical Reference Material Dispensing Apparatus—Single Buret Style

TABLE X1.1 Typical Single Buret Style Specifications

Buret capacity	mL	500
Automatic zero		Yes
Graduations:		
major marks	%	5
minor marks	%	1
Internal diameter of graduated tube:		
minimum	mm	32
maximum	mm	34
Scale length, 5 to 100 %:		
minimum	mm	523
maximum	mm	591
Length, top of overflow bulk to 5 % mark (nominal)	mm	100/120
Overall length (including tip):		
minimum	mm	650
Scale error (maximum)	%	±0.1

X1.3.1.2 *Two Buret Style*—Typical burets of both types are illustrated in Fig. X1.2. Specifications for these burets applicable for a blend volume of 400 mL are given in Table X1.2.

(1) One type consists of an automatic zero and overflow dome, a glass half-capacity bulb, and a straight graduated section. This buret is calibrated from 0 to 50 % on one side of the straight section and 50 to 100 % on the other side of the straight section.

(2) The second type consists of an automatic zero and overflow dome and just a straight graduated section, calibrated on one side from 0 to 50 % and on the other side from 50 to 100 %.

X1.3.2 *Separate Dispensing Valves*—It is common practice to utilize burets that do not have a dispensing stopcock. Bottom delivery from the buret is from a straight tubing bib that is connected by plastic tubing to a three-way valve similar to that shown in Fig. X1.3. The most important feature of such a valve assembly is the dispensing fitting, which is formed so that only a very minimum of drip can occur if the collection container is inadvertently touched against the orifice tip.

X1.4 *System Installation and Operation*—User experience with reference fuel systems has pointed out a number of important aspects that support the following recommendations:

X1.4.1 Install a separate buret for each reference and standardization fuel.

X1.4.2 Mount burets vertically at an elevation that permits horizontal sighting of all calibration marks.

X1.4.3 To minimize blending error, the dispensing system, including the buret and delivery valve, shall include a restriction, external to the buret, to limit the flow to no more than 400 mL/min.

X1.4.4 Mount burets in a manner that ensures freedom from vibration.

X1.4.5 Store bulk reference fuel containers and provide appropriate tubing for delivery of the fuels to the dispensing burets in accordance with the instructions of the manufacturer and in compliance with all local codes and regulations.

X1.1 *Background*—PRFs and TSF are supplied in bulk containers of 5 and 55 U.S. gallon capacity (0.019 or 0.208 m³) and for laboratory safety reasons these quantities are typically stored in a special fuel storage room or outside of the engine laboratory.

X1.2 *Delivery from Storage*—Delivery of reference fuel material from the bulk storage container to a dispensing apparatus in the engine laboratory may be handled in any of several ways. The equipment and procedures required for delivery of the reference fuel materials are the responsibility of the user of this standard.

X1.3 *Dispensing Equipment*—A common means of accurately measuring reference fuel blend volumes applies a matched set of calibrated glass burets, one for each of the four fuels that are the blend constituents. Fuel is dispensed either through an internal glass stopcock or a separate valve.

X1.3.1 Burets of glass with an automatic zero top fitting provide accurate, efficient, and convenient measurement. Two styles are commercially available: single burets having graduations from 0 to 100 %, and a two buret combination with the graduated section of each measuring just 50 % of the batch amount.

X1.3.1.1 *Single Buret Style*—A glass buret with an automatic zero and overflow dome as illustrated in Fig. X1.1. Burets of this style are commonly fabricated in 300-, 400-, or 500-mL capacities. Specifications for a typical 500-mL buret are given in Table X1.1.

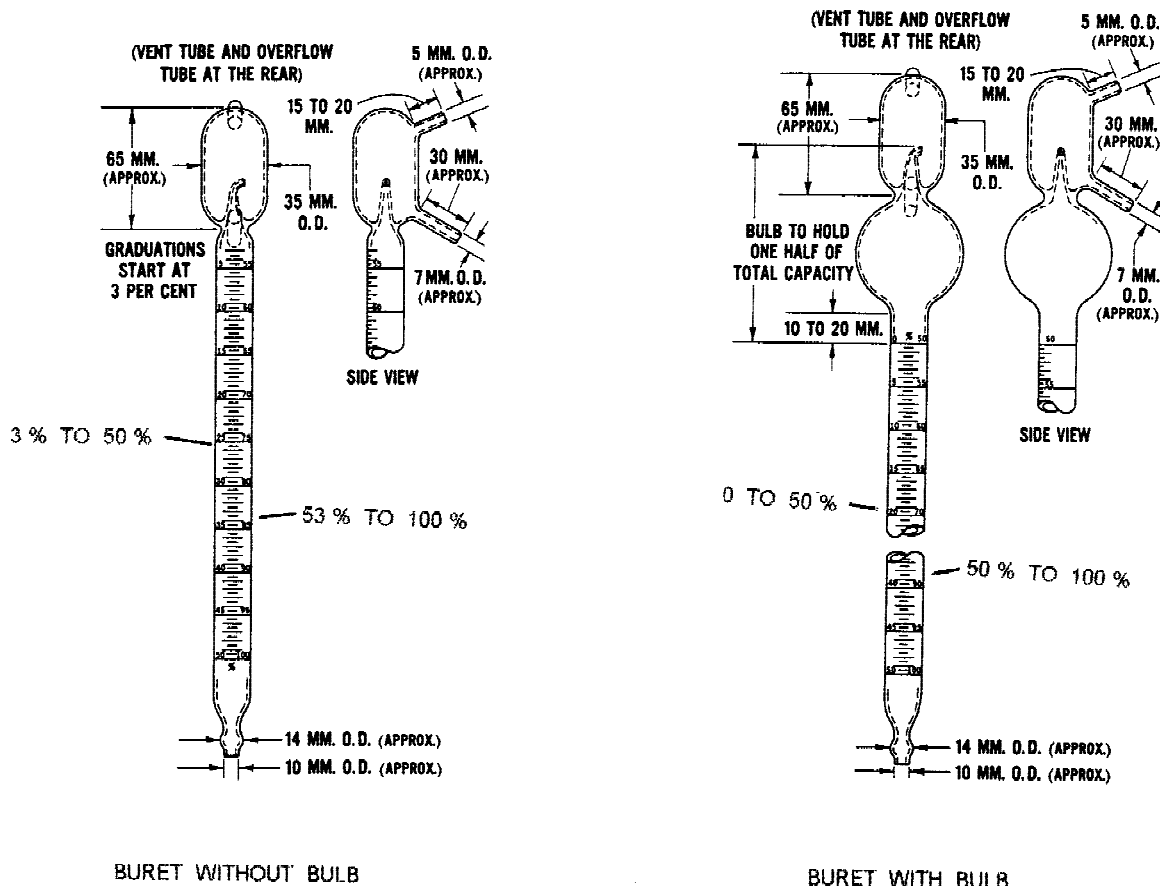

FIG. X1.2 Typical Reference Material Dispensing Apparatus Two-Buret Style

X1.4.5.1 Equip bulk reference fuel containers with vacuum/pressure relief fittings to maintain container internal pressure close to atmospheric pressure and minimize container vapor space breathing to the atmosphere.

X1.4.5.2 Connect bulk fuel containers to dispensing burets using stainless steel or other opaque tubing that will not react with the reference fuel.

X1.4.5.3 Avoid the use of gravity flow delivery of reference or standardization fuel to burets.

X1.4.6 Thoroughly clean burets on a regular basis to minimize hang-up or clinging on the inner surface of the buret that can lead to blending errors.

X1.4.7 Avoid filling burets until a blend is required in order to minimize any tendency for deterioration of the fuel by exposure to light.

X1.5 Procedure for Use of Buret System:

X1.5.1 To fill the buret, set the valve or stopcock to FILL position so that fuel rises in the buret until it overflows at the automatic zero. Stop filling by setting the valve to OFF position. Check that any bubbles are purged at the zero tip and refill the tip, if necessary.

X1.5.2 To dispense fuel, set the valve to DISPENSE position so that fuel is delivered to the collection container. Stop dispensing by setting the valve to OFF position while carefully noting the level of the fuel in the calibrated section of the buret and locating the bottom of the liquid meniscus at the desired volume percent mark.

X1.5.3 Before drawing a measured volume, make certain that the tip of the dispensing tube is full. When the measured volume has been collected, be certain not to drain any fuel from the tip of the dispensing tube as this will cause an error.

TABLE X1.2 Typical Two Buret Style Specifications

Buret Without Half-Capacity Bulb		
Buret capacity	mL	200
Automatic zero		Yes
Graduations:		
left side	%	0 to 50
right side	%	50 to 100
Internal diameter of graduated tube:		
minimum	mm	21.2
maximum	mm	22.5
Scale length:		
minimum, 5 to 50 % and 55 to 100 %	mm	450
maximum, 5 to 55 % and 55 to 100 %	mm	495
Length, bottom of overflow bulb to lower end:		
minimum	mm	595
maximum	mm	605
Scale error (maximum)	%	±0.1
Buret With Half-Capacity Bulb		
Buret capacity	mL	400
Automatic zero		Yes
Outside diameter of half-capacity bulb (approximate)	mm	81
Graduations on straight section:		
left side	%	0 to 50
right side	%	50 to 100
Internal diameter of graduated tube:		
minimum	mm	21.5
maximum	mm	22.5
Scale length:		
minimum, 5 to 50 and 55 to 100 %	mm	500
maximum, 5 to 50 and 55 to 100 %	mm	550
Length, bottom of half-capacity bulb to lower end:		
minimum	mm	620
maximum	mm	630
Scale error (maximum)	%	±0.1

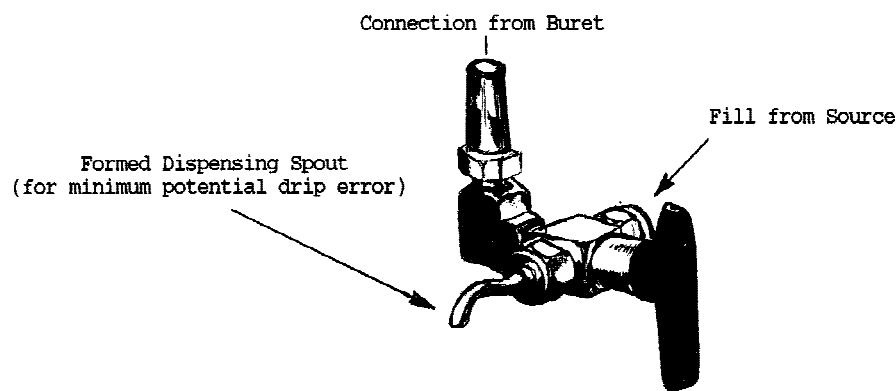

FIG. X1.3 Typical Fill/Dispense Valve

X2. OPERATING TECHNIQUES—ADJUSTMENT OF VARIABLES

X2.1 *Adjusting C.R.*—C.R. varies when the cylinder is moved up and down in the clamping sleeve by means of a worm-gear drive, which is operated either by a hand crank or by an instrument panel controlled gearmotor.

X2.1.1 When the unit is equipped with a hand crank, the cylinder clamping sleeve cam lever must be loosened before cranking in either direction. To increase C.R., lower the cylinder in the sleeve, rotate the crank in a counterclockwise direction. To decrease C.R., rotate the crank in a clockwise direction. After each change of cylinder position, move the cam lever so that the cam flat contacts the clamping washers to

tighten the clamping sleeve, thereby applying a repeatable pressure on the clamping sleeve. The cam lever setting should maintain constant cylinder clamp tightness regardless of the angular position of the crank after a change. Typically, with the cam in the locked position, 10 lbf-ft torque on the cam stud nuts is adequate, but torque should never exceed 25 lbf-ft to avoid cylinder distortion.

X2.1.2 Units equipped with a motorized C.R. change motor, do not require loosening of the cylinder clamp when a C.R. change is made. The gearmotor is equipped with a brake that prevents worm shaft rotation unless the motor is operated. A

solenoid releases the brake when the motor is actuated in either direction. Although the cam lever is unnecessary for units equipped with the motor changer, the clamping sleeve bolt and nut combination must be tightened slightly to prevent vibration of the cylinder in the sleeve. A torque setting of approximately 5 lbf-ft on the clamp nuts is typically effective.

X2.1.3 Measurement of cylinder height is accomplished using either a dial indicator assembly mounted on the cylinder and clamping sleeve or through use of the digital counter that is driven by the worm screw to provide a reading for each cylinder position. These devices require indexing to a specific cylinder position each time a unit is reassembled. The dial indicator and digital counter readings are thus related to engine C.R.

X2.2 Fuel-Air Ratio Adjustment:

X2.2.1 All O.N. determinations require that the knockmeter reading of significance be that which occurs at the fuel-air ratio that causes a maximum knock condition. This applies to both sample fuels and reference fuel blends. Fuel-air ratio is adjusted by raising or lowering the fuel level in the carburetor vertical jet. For the typical float reservoir equipped engine, fuel level in the sight glass is adjusted by turning the screw knob at the bottom of the float reservoir assembly. To ensure satisfactory fuel atomization, it is required that the fuel level for maximum knock be between 0.7 and 1.7 on the sight glass. If this is not the case, the horizontal metering jet (in the passage between the sight glass and selector-valve) must be changed to a different size. If the fuel level is too high, a larger orifice horizontal jet is needed, and vice versa.

X2.2.2 Use of the falling level principle, which uses a bowl of specific cross-sectional area to deliver fuel to the horizontal jet, accomplishes the same function. As the charge of fuel is consumed, the level automatically falls and the maximum knockmeter reading can be observed. Fuel-air ratio changes can also be accomplished by maintaining a constant fuel level to an adjustable valve installed instead of the fixed orifice horizontal jet. Opening the adjusting valve richens the mixture and vice versa.

X2.3 Preparations Before Starting the Engine:

X2.3.1 Check the jacket coolant level in the condenser sight glass.

X2.3.2 Check the engine crankcase lubricating oil level in the crankcase oil sight glass.

X2.3.3 Turn on the crankcase oil heater or oil heat temperature controller. Normally, if the temperature controller is left on at a setting of approximately 8, the oil will stay near the proper operating temperature.

X2.3.4 Check the engine crankcase breather assembly to ensure it is clean and operable.

X2.3.5 If an ice tower is used, fill the tower with ice. The depth of ice in the tower should not be allowed to be less than 920 mm (approximately 36 in.). If an intake air refrigeration unit is used, turn the switch on.

X2.3.6 Adjust the cylinder height to ensure that the C.R. is low enough that severe knock is avoided when the engine is firing.

X2.3.7 Lightly tap the fuel selector-valve knob in a downward direction using a screwdriver handle or other similar tool. This will ensure the plug is not seized in the valve body when it is necessary to rotate the valve. (**Warning**—Avoid attempting to rotate the selector-valve knob if it resists turning. Rotation can score the plug and valve body and cause fuel leakage.)

X2.3.8 Fill one of the fuel tanks with the selected warm-up fuel, and purge any air bubbles from the tubing and sight glass. Adjust the fuel level so that the engine will operate at approximately the fuel-air ratio for maximum K.I.

X2.3.9 Open the cooling water valve or check that cooling water will be available for the coolant condenser when the engine is started.

X2.3.10 Check that the ignition switch is turned off.

X2.3.11 Manually rotate the engine crankshaft three or four complete revolutions to ensure that all parts move freely. Complete the cranking so that the flywheel is positioned at tdc on the compression stroke to minimize the load on the synchronous-reluctance motor when the engine is started.

X2.4 *Starting the Engine*—It is assumed that the engine has been commissioned and is in operable condition and that electrical circuits and cooling water are available on demand.

X2.4.1 Check that the fuel-selector valve is positioned between two bowl marks so that fuel will not enter the carburetor initially.

X2.4.2 Position the off-run-start switch to start and hold it in start position for a few seconds to allow oil pressure to rise sufficiently to actuate the engine run circuitry so that the engine continues to operate when the start switch is released to the run position.

X2.4.3 Check that the temperature controller for the air/mixture heater(s) is on and functioning.

X2.4.4 Rotate the fuel selector-valve to deliver the warm-up fuel to the combustion chamber.

X2.4.5 Turn on the ignition switch so that the engine begins to fire.

X2.4.6 As the engine begins to warm up, adjust the cylinder height to produce a very light knock sound. As warm-up progresses, the knock level will increase.

X2.4.7 Oil the rocker arm assembly using SAE 30 Grade engine crankcase lubricating oil.

X2.4.8 During the warm-up period, observe the following conditions:

X2.4.8.1 Oil pressure is steady and within specification.

X2.4.8.2 Crankcase pressure indicates a slight vacuum.

X2.4.8.3 Temperatures come to equilibrium within specification.

X2.4.8.4 The cylinder jacket coolant water rises in the condenser sight glass until it is at the LEVEL HOT mark.

X2.4.8.5 Cooling water is discharged from the unit at a steady rate.

X2.4.9 As a final check before using the engine for rating, perform the following:

X2.4.9.1 Check valve clearances, hot and running, and make any necessary adjustments.

X2.4.9.2 Check spark timing.

X2.4.9.3 Switch to a PRF blend of appropriate O.N., set the cylinder height to the guide table value, compensated for barometric pressure, adjust the carburetor fuel level to obtain maximum knockmeter reading, and set the detonation meter METER READING and SPREAD dials to provide satisfactory spread with the knockmeter reading at 50.

X2.5 *Stopping the Engine:*

X2.5.1 To stop the engine, turn the ignition switch to OFF and position the stop/run/start switch to STOP.

X2.5.2 Drain all fuel from the engine carburetor.

X2.5.3 Using the hand crank, manually rotate the crankshaft to position it at tdc on the compression stroke so that the intake and exhaust valves are closed. This will minimize possible valve warpage or corrosion in the combustion chamber between operating periods.

X2.5.4 Turn off the cooling water to the coolant condenser.

X2.6 *Checking Exhaust and Crankcase Breather Systems for Resonance:*

X2.6.1 Resonance in the piping systems can occur when the configuration creates a critical length/volume relationship. A resonant condition affects the primary pressure within the system and can affect critical operating conditions.

X2.6.2 Exhaust system resonance may be checked by providing either a ¾-in. or larger gate or ball valve at the exhaust surge tank or close to the engine exhaust port. Opening the valve should drastically change the exhaust discharge configuration while the engine is operating at standard conditions if resonance is occurring.

X2.6.2.1 Operate the engine at standard conditions on a typical sample or reference fuel and allow sufficient time for the knockmeter reading to stabilize. Observe the knockmeter reading.

X2.6.2.2 Open the valve or affect the change in exhaust piping while the engine continues to operate.

X2.6.2.3 If the knockmeter reading is not affected, resonance does not occur and the piping system is satisfactory.

X2.6.2.4 If the knockmeter reading is affected when the valve is opened, resonance may be a factor and typically a change in the length of the exhaust discharge pipe will correct the condition.

X2.6.3 Crankcase breather system resonance typically causes the crankcase pressure to be positive. Resonance in the discharge piping is not a problem as long as the operating engine creates a crankcase vacuum.

X3. MAINTENANCE TECHNIQUES

X3.1 *Importance of Maintenance*—The need for proper maintenance of the knock testing unit cannot be overemphasized if reliable O.N. ratings of sample fuels are to be obtained. The care used in the inspection, adjustment, and especially the overhaul of the combustion chamber components is a major factor in achieving these aims.

X3.2 *Types of Maintenance:*

X3.2.1 *Daily Checks*—Those checks associated with the preparations before starting the engine as detailed in Appendix X2.

X3.2.2 *Top Overhaul*—The generally accepted term used to describe valve reconditioning, the cleaning of the combustion chamber, piston, piston rings, and the cleaning of the coolant jacket passages and the coolant condenser. Some other parts may also be given attention during a top overhaul, depending on need.

X3.2.3 *Crankcase/Unit Inspection*—Encompasses crankcase cleaning, mechanical component wear checks, alarm function checks, power absorption motor inspection, belt tension adjustment, instrumentation checks, and so forth.

X3.2.3.1 The recommended interval between crankcase/unit inspections is every 2000 h of operation or biannually, whichever comes first. Model CFR-48 crankcases can be completely restored by the manufacturer. (**Warning**—Deactivate the engine unit before performing any maintenance. Shut off electrical power at the main disconnect, lock out, if possible. Place a **WARNING** notice on the unit panel indicating repairs are in process and that no attempt is to be made to start the engine. Shut off coolant water to the unit.)

X3.2.4 *Auxiliary Equipment Maintenance*—Volumetric glassware such as reference fuel blending burets should be chemically cleaned on a regular basis to ensure accurate volumetric measurement.

X3.2.4.1 Quarterly cleaning of volumetric apparatus is recommended.

X3.2.5 *Carbon Blasting*—Combustion chamber deposits can be effectively removed by carbon blasting without removal of the cylinder from the engine. Performed on a regular basis between top overhauls, this technique effectively extends the period of time between these mechanical overhauls.²⁶

X3.2.5.1 Blasting is done through the intake and exhaust ports and the spark plug hole. The return line for removal of the deposits and spent blasting material is attached to the hole for the detonation pickup.

X3.2.5.2 Complete blasting procedure instructions are included with the carbon blasting kit and all phases of the procedure should be carried out for effective results.

X3.3 *Top Overhaul Procedures:*

X3.3.1 Disassemble the complete cylinder/clamping sleeve assembly from the engine crankcase. Components to be removed include:

X3.3.1.1 Detonation pickup, spark plug, all thermometers and temperature sensors.

X3.3.1.2 C.R. gearmotor assembly from the clamping sleeve. If a dial indicator is in use, remove it from the cylinder.

²⁶ A carbon blaster kit specific for CFR engine units is available from Waukesha Engine Division, Dresser Industries, Inc., 1000 St. Paul Ave., Waukesha, WI 53188.

X3.3.1.3 All intake air system components, the carburetor, carburetor heat shield, and the intake mixture manifold assembly.

X3.3.1.4 Cooling water lines at the coolant condenser and the exhaust pipe.

X3.3.1.5 Disconnect the applicable exhaust system components from the cylinder exhaust port.

X3.3.1.6 Coolant condenser and water return pipe from the cylinder assembly.

X3.3.1.7 Disconnect the spark advance bracket from the cylinder.

X3.3.1.8 Loosen the long rocker arm support bolts which fasten the support to the clamping sleeve. Remove the valve half-balls. Remove the push rods.

NOTE X3.1—Marking of push rods as intake and exhaust ensures they will be reassembled in the same positions.

X3.3.1.9 Cylinder and clamping sleeve as an assembly after removal of the five clamping sleeve stud nuts.

X3.3.1.10 Piston from connecting rod.

X3.3.2 Separate the cylinder from the clamping sleeve as follows:

X3.3.2.1 Remove the two bolts from the long rocker arm support and separate the support from the clamping sleeve.

X3.3.2.2 Remove the water inlet pipe assembly from the cylinder.

X3.3.2.3 Remove the cylinder from the clamping sleeve.

X3.3.3 Disassemble the valve tapers, retainer and rotator assembly, springs, and valves from the cylinder. Remove the roll pin from the intake valve stem to remove this valve.

X3.3.4 *Component Cleaning*—All combustion deposits, gasket material, rust, and so forth should be removed from components.

X3.3.4.1 Commercial chemical cleaning solutions may be used in accordance with manufacturer's instructions as long as they do not etch or affect the surface finish of the machined surfaces. Except for the detonation pickup and temperature sensors, use of ultrasonic bath equipment has been demonstrated to be effective and the heating of some cleaning solutions can also be beneficial. (**Warning**—Chemical cleaning solutions are poisonous and may be harmful or fatal if inhaled or swallowed. See Annex A1.)

X3.3.4.2 Scraping, brass wire brushes (manually or power driven), and fine steel wool have been found to be effective cleaning aids.

X3.3.4.3 Complete any cleaning sequence by rinsing all parts with a solvent.

X3.3.5 *Cylinder:*

X3.3.5.1 Check the cylinder bore diameter at the top, middle, and bottom areas of ring travel in two planes, which are 90° apart. Replace the cylinder if the internal diameter at the area of maximum wear is more than 0.006-in. larger than the unworn skirt internal diameter. Replace the cylinder if the bore is out-of-round in excess of 0.0025 in.

X3.3.5.2 Cylinders rebored to 0.010, 0.020, and 0.030 in. larger than the original 3.250-in. diameter are permitted and the same wear limits apply based on the unworn skirt diameter of the rebore.

X3.3.5.3 *Valve Guides*—Replace a guide when the internal diameter exceeds the wear limit. Replacement requires special tools.

X3.3.5.4 *Valves*—Replace if stem is badly scuffed or stem diameter is less than the replacement limit. Reface to 45° using a valve refacing (grinding) machine so that face runout is less than 0.0015 in. Replace the valve if grinding has created a margin of less than 1/32 in.

X3.3.5.5 *Valve Seats*—Reface seats using a valve seat grinding machine or a valve seat cutter kit. Use a 45° seat angle and subsequently lap the valve to the seat. Alternatively, an interference angle approach may be utilized by refacing the seat at both 46 and 15° so that the intersecting line becomes the contact surface with a 45° faced valve. When an interference angle approach is utilized, lapping may be performed, but extreme care must be taken to exert very light pressure to prevent creating a groove in the valve face.

X3.3.5.6 *Valve to Valve Seat Match-up*—Check the valve to seat contact. Lapped valve seat width must not exceed 0.070 in. as viewed on the valve. The top edge of the contact line or area shall be at least 0.030 in. from the top edge of the faced portion of the valve.

X3.3.5.7 *Valve Rotators*—Inspect the races, which should rotate freely, so that when the engine is operating, the valve rotates at approximately 1 to 2 rpm.

X3.3.5.8 *Valve Reassembly*—Install valves in the cylinder with felt lubrication washers, springs, retainer (intake), rotator assembly (exhaust), and tapers. Carefully install the intake valve with the opening of the shroud facing the pickup hole before inserting the roll pin into the valve stem through the slot in the valve guide. Install valve springs with closely wound coils next to the cylinder oil tray.

X3.3.5.9 *Rocker Arm Assembly:*

(1) Inspect each rocker for excessive bearing wear or wobble of the rocker shaft.

(2) Inspect the rocker adjusting screws for galled ball ends and also for damaged Phillips screwdriver slots.

(3) Inspect the rocker ball sockets for wear or galling.

(4) Replace any worn or out of specification parts.

X3.3.6 *Piston and Rings:*

X3.3.6.1 Replace the piston if there is evidence of scoring or a wear pattern.

X3.3.6.2 Replacement of all rings at the time of every overhaul is typical. A chrome plated top compression ring may be reused for several overhaul periods.

X3.3.6.3 Ring gaps should be checked by feeler gage with the ring inserted in the skirt end of the cylinder. The piston should be used to square the ring in the bore about 1 in. beyond the chamfer. Rings should be replaced if the gap exceeds the replacement limit.

X3.3.6.4 Ring-to-land clearances should be checked, using a feeler gage, after the rings are assembled on the piston. Replace the piston if the clearances exceed the tolerance limits.

X3.3.6.5 Replace the piston pin if scoring or wear marks are observed on the pin.

X3.3.7 *Clamping Sleeve:*

X3.3.7.1 Check that the internal bore of the sleeve is within tolerance.

X3.3.7.2 Check that the counterbore for the worm wheel is within tolerance.

X3.3.7.3 Insert the worm wheel in the clamping sleeve and check that the distance between the worm wheel face and that of the bottom of the sleeve is within tolerance.

X3.3.7.4 Inspect the worm shaft ball and thrust bearings and replace as required.

X3.3.8 Cylinder Guide Plate:

X3.3.8.1 Inspect the wear surface that contacts the worm wheel. Replace the guide plate if there is wear or scoring.

X3.3.9 Condenser and Cooling System:

X3.3.9.1 Inspect the inner surfaces of the condenser and the baffle tube for rust or scale deposits, wipe out the cavity, and rinse with hot water prior to assembly.

X3.3.9.2 Inspect the cooling coil, clean surface deposits, and observe that the coils are slightly separated from each other to maximize the cooling surface exposed to coolant steam.

X3.3.9.3 Chemical cleaning of coolant system surfaces should take place whenever significant deposits are observed or at least at every third top overhaul. One approach is to introduce a commercial cooling system cleaner in the cooling system after reassembly of the engine. By running the engine for intermittent periods, the solution can be heated to 80 to 90°C (180 to 200°F). The solution should be kept at this temperature for approximately 30 min and drained. The system should then be flushed with clean hot water before recharging with a rust inhibited coolant water. (**Warning**—Chemical cleaning solutions are poisonous and may be harmful or fatal if inhaled or swallowed. See Annex A1.)

X3.3.10 Intake Mixture Manifold:

X3.3.10.1 Disassemble the manifold heater assembly from the manifold.

X3.3.10.2 Carefully remove the deposits from all heater blade surfaces.

X3.3.10.3 Clean the internal passage of the manifold.

X3.3.10.4 Clean and inspect the intake mixture thermometer assembly.

X3.3.10.5 Reassemble the manifold heater assembly in the manifold.

X3.3.11 Reassembly Procedures:

X3.3.11.1 Install the piston, piston pin, and pin retainers on the connecting rod. Lubricate the rings with SAE 30 Grade engine crankcase oil.

X3.3.11.2 Reassemble the cylinder in the clamping sleeve so that the skirt of the cylinder extends at least ¼ in. past the bottom of the sleeve. Check that the proper number of worm shaft shims are used so that the worm shaft end play is minimal (typically ⅛ turn of the shaft).

X3.3.11.3 Connect the long rocker arm support to the clamping sleeve.

X3.3.11.4 Assemble the cylinder guide plate with its gaskets on the crankcase.

X3.3.11.5 Rigidly support the piston above the crankcase and guide plate. Install the cylinder/clamping sleeve assembly over the piston so that it is seated on the crankcase. Care should be taken not to break any of the rings as they enter the chamfered bore. (Use of a ring compressor tool over the piston rings is advisable despite the cylinder chamfer.) Manually

rotate the crankshaft through several revolutions so that the cylinder is centered. Tighten and torque the cylinder stud nuts as specified in Table A4.1.

X3.3.11.6 Manually rotate the crankshaft so that the piston is at tdc on the compression stroke as indicated by the flywheel pointer.

X3.3.11.7 Install the marked push rods and the valve half-balls. Reposition the long rocker arm support as required, tighten the support bolts, and check that the rocker carrier and rocker arms are level.

X3.3.11.8 Set the valve clearances to 0.075 mm (0.004 in.) for the intake valve and 0.330 mm (0.014 in.) for the exhaust valve.

X3.3.11.9 Connect the appropriate exhaust system components to the cylinder exhaust port.

X3.3.11.10 Install the water inlet pipe, water return pipe, the coolant condenser, and the cooling water lines.

X3.3.11.11 Install the C.R. gearmotor assembly and the dial indicator assembly, if used.

X3.3.11.12 Reconnect the spark advance bracket to the cylinder.

X3.3.11.13 Install the intake mixture manifold assembly, carburetor heat shield, and all intake air system components.

X3.3.12 Crankcase Breather:

X3.3.12.1 Disconnect the breather pipe and remove the breather assembly from the engine crankcase.

X3.3.12.2 Unscrew the cap from the body, remove the plastic cup, and clean the emulsion deposits from all of the pieces.

X3.3.12.3 Inspect the cup, and if the surface of the open edge is rounded rather than square, replace the cup.

X3.3.12.4 Rinse the components using a petroleum based solvent or kerosine and reassemble them on the engine. (**Warning**—Petroleum based solvent is flammable and its vapors are harmful if inhaled. Vapors may cause flash fire. See Appendix X1.) (**Warning**—Kerosine is combustible and its vapors are harmful. See Annex A1.)

X3.3.13 Crankcase Oil Change:

X3.3.13.1 Drain the used oil and add new SAE 30 Grade engine crankcase lubricating oil.

X3.3.13.2 It is recommended that the crankcase lubricating oil be changed at intervals of approximately 50 h of engine operation and at the time of each top overhaul.

X3.3.13.3 It is recommended that the oil filter cartridge be changed at the time of every other oil change.

X3.4 Engine Starting Preparations—See Appendix X2.

X3.5 Crankcase/Unit Inspection:

X3.5.1 *Crankcase*—Inspect the crankcase periodically as follows:

X3.5.1.1 Turn off the electrical power circuits to the engine and unit.

X3.5.1.2 Drain the crankcase lubricating oil and clean the crankcase sump using a petroleum based solvent.

X3.5.1.3 Disassemble the oil suction screen assembly and clean the components.

X3.5.1.4 Disassemble the crankcase breather body from the crankcase door and clean the internal passage and baffles.

X3.5.1.5 Disassemble the connecting rod from the crankshaft. Inspect the big end bearing shells and replace if wear is indicated. Reassemble the connecting rod and torque the cap bolts as specified in Annex A4, Table A4.1.

X3.5.1.6 Disassemble the valve lifters from the top of the crankcase, clean, inspect, and if necessary, replace worn assembly components.

X3.5.1.7 Approximate the rear main bearing clearance by dial indicator measurement of the movement of the crankcase edge of the flywheel outer surface. Measure with the flywheel at rest and then with the flywheel lifted using an appropriate lever. If the difference in the measurements exceeds 0.006 in., crankcase rebuilding is recommended.

X3.5.1.8 Disassemble the oil pressure control valve assembly, solvent clean, inspect for worn components and replace as required. (**Warning**—In addition to other precautions, avoid over tightening the four control valve body fastening bolts to prevent valve body distortion and restriction of the plunger movement.)

X3.5.1.9 Inspect the outer crankcase surfaces for indications of oil seal leakage which may require extensive maintenance or crankcase rebuilding.

X3.5.2 *Power Absorption Motor*—Inspect the power absorption motor annually as follows:

X3.5.2.1 Turn off all the electrical power circuits to the engine and unit.

X3.5.2.2 Check the condition and tension of the drive belts. Replace belts as required and adjust the motor position to achieve proper belt tension.

X3.5.2.3 Remove dust and dirt from the end bell openings using low pressure compressed air.

X3.5.3 *Safety Cutoff Checks:*

X3.5.3.1 *High Coolant Temperature Switch*—After shutting off the cooling water to the condenser coil, the engine should stop within 1 min. Check and adjust the thermal switch set point as required.

X3.5.3.2 *Low Oil Pressure Switch*—When starting the engine, release of the momentary start switch before the oil pressure reaches approximately 20 psi (138 kPa) should result in unit shut down.

X3.5.3.3 *Electrical Interlock*—Disconnecting either the single phase or three phase power at the appropriate supply switch should cause unit shut down.

SUMMARY OF CHANGES

Subcommittee D02.01 has identified the location of selected changes to this standard since the last issue (D 2700–03a) that may impact the use of this standard. (Approved Nov. 1, 2003.)

(1) Added “untuned” as an adjective for TSF blend rating in 11.3.3 and 11.3.5.

Subcommittee D02.01 has identified the location of selected changes to this standard since the last issue (D 2700–03) that may impact the use of this standard. (Approved Aug. 10, 2003.)

(1) Added 11.3.2.1 on MIXT tuning.

Subcommittee D02.01 has identified the location of selected changes to this standard since the last issue (D 2700–02) that may impact the use of this standard. (Approved June 10, 2003.)

(1) Revised 7.3 to allow for gravimetric blending of reference fuels.

(2) Revised A1.1.1, A1.2, A1.3, and A1.4.

(3) Revised X1.4 for clarity and emphasis.

ASTM International takes no position respecting the validity of any patent rights asserted in connection with any item mentioned in this standard. Users of this standard are expressly advised that determination of the validity of any such patent rights, and the risk of infringement of such rights, are entirely their own responsibility.

This standard is subject to revision at any time by the responsible technical committee and must be reviewed every five years and if not revised, either reapproved or withdrawn. Your comments are invited either for revision of this standard or for additional standards and should be addressed to ASTM International Headquarters. Your comments will receive careful consideration at a meeting of the responsible technical committee, which you may attend. If you feel that your comments have not received a fair hearing you should make your views known to the ASTM Committee on Standards, at the address shown below.

This standard is copyrighted by ASTM International, 100 Barr Harbor Drive, PO Box C700, West Conshohocken, PA 19428-2959, United States. Individual reprints (single or multiple copies) of this standard may be obtained by contacting ASTM at the above address or at 610-832-9585 (phone), 610-832-9555 (fax), or service@astm.org (e-mail); or through the ASTM website (www.astm.org).